



MESSZEUGE LEHREN  
MEASURING TOOLS GAUGES

DE GB 16/17

ULTRAPRÄZISION  
MESSZEUGE GMBH



TRADITION • PRÄZISION • INNOVATION seit 1888

TRADITION • PRECISION • INNOVATION since 1888



## Tabellen-Icons

### Table icons:

	Artikelnummer Article number
	Eigengewicht Own weight
	Genauigkeitsgrad Accuracy grade
	Nennmaß Nominal size
	Stufung Step
	Ablesung Reading
	Mess- / Verstellbereich Measuring / Adjusting range
	Schnabellänge Jaw length
	Brückenlänge Bridge length
	Messtiefe Measuring depth
	Bügeltiefe Frame depth
	Ausladung Throat
	Höhe Height
	Breite / Länge Width / Length
	Größe x/y Dimension x/y
	Größe x/y/z Dimension x/y/z
	Messfläche / Wägeplatte Meas. surface / Weighing plate
	Querschnitt Cross section
	Säulen- / Gehäuse Ø Column / Housing Ø
	Geradheit Straightness
	Winkligkeit Angularity
	Parallelität Parallelism
	Zylinderform Cylindrical form
	Ebenheit Flatness
	Winkel Angle
	Verlängerung Extension
	Skala Scale
	Umdrehung im Uhrzeigersinn Rotation clockwise
	Umdrehung gegen Uhrzeigersinn Rotation anti-clockwise
	Messkraft / Teilengew. / Nennlast Meas. force / Piece weight / Load
	Hafkraft Adhesive force
	Vergrößerung Magnification

## Aufbau

### der Artikeldaten:

## Structure

### of the article data:

Produkttitel	Product title																
► Beschreibung	► Description																
<b>1234 1.. :</b> Produktvariante	<b>1234 1.. :</b> Product version																
<b>1235 1.. :</b> Zubehör	<b>1235 1.. :</b> Accessories																
Hinweise	Note																
<table border="1"> <thead> <tr> <th></th> <th></th> <th>Nº</th> <th>Nº</th> </tr> </thead> <tbody> <tr> <td>0 – 50</td> <td>0,04</td> <td>1234 101</td> <td>1235 101</td> </tr> <tr> <td>50 – 100</td> <td>0,08</td> <td>1234 102</td> <td>1235 102</td> </tr> <tr> <td>100 – 200</td> <td>0,20</td> <td>1234 103</td> <td>1235 103</td> </tr> </tbody> </table>			Nº	Nº	0 – 50	0,04	1234 101	1235 101	50 – 100	0,08	1234 102	1235 102	100 – 200	0,20	1234 103	1235 103	
		Nº	Nº														
0 – 50	0,04	1234 101	1235 101														
50 – 100	0,08	1234 102	1235 102														
100 – 200	0,20	1234 103	1235 103														

## Herkunft

### unserer Produkte:

	Hergestellt in Deutschland. Made in Germany.
	Hergestellt in der Schweiz. Made in Swiss.
	Hergestellt in Zentral-Europa. Made in Central Europe.
	Hergestellt in Zentral-Europa. Design und/oder Finish in Deutschland. Made in Central Europe. Design and/or finishing in Germany.
	Hergestellt außerhalb Europa. Made outside Europe.
	Hergestellt außerhalb Europa. Design und/oder Finish in Deutschland. Made outside Europe. Design and/or finishing in Germany.

## Origin

### of our products:

**ULTRAPRÄZISION**   
MESSZEUGE GMBH



P.O. Box 10 07 52  
63705 Aschaffenburg / Germany

**E-Mail:** info@ultra-germany.com  
**Web:** www.ultra-germany.com















**Fachberatung:**  
Montag bis Freitag  
von 8:00 bis 16:00 Uhr:

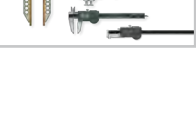

Weitzkaut 3  
63864 Glattbach / Germany

**Fon:** +49 (0) 60 21 42 999 00  
**Fax:** +49 (0) 60 21 42 999 01

**Consultancy:**  
Monday to friday  
between 8 a.m. and 4 p.m.:

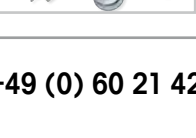
1		Endmaße, Endmaßzubehör, Plangläser, Messkugeln Gauge blocks, Gauge block accessories, Optical flats, Measuring balls	1
2		Prüfstifte, Lehrdorne, Kegellehren, SK/HSK Messgeräte, Einstellringe, Rachenlehren Pin / Plug gauges, Taper gauges, SK/HSK meas. devices, Setting rings, Snap gauges	2
3		Gewindelehren, Nutenlehren, Vierkant- Sechskantlehren, Verzahnungslehren Thread gauges, Shaft keyway gauges, Square / Hexagonal gauges, Serration gauges	3
4		Feinzeiger, Messuhren, Fühlhebelmessgeräte Comparator gauges, Dial gauges, Dial test indicators	4
5		Messstative, Messuhrständer, Feinmesstische Measuring stands, Dial gauge stands, Precision measuring tables	5
6		Schnelltaster, Dickenmessgeräte, Voreinstellgeräte, Innenfeinmessgeräte, Zentriergeräte Dial caliper gauges, Pre-setting devices, Depth gauges, Bore gauges, Centring devices	6
7		Wellenmessvorrichtungen, Messplatten, Richtplatten, Rundlaufprüfgeräte, Spindelstöcke Shaft measuring systems, Surface plates, Straightening plates, Concentricity testers, Headstocks	7
8		Schraubstöcke, Sinustische, Aufspanwinkel, Winkelnormale, Prismen, Messbalken Precision vices, Sine tables, Angle plates, Master squares, V-Blocks, Straightedges	8
9		Lineale, Maßstäbe, Bandmaße, Klein-Lehren Straightedges, Rules, Measuring tapes, Small gauges	9
10		Winkel, Winkelmesser, Gradmesser, Richtwaagen, Wasserwaagen Squares, Bevel protractors, Protractors, Engineer's levels, Spirit levels	10
11		Messschieber, Tiefenmessschieber, Datenübertragung Vernier calipers, Depth calipers, Data transmission	11
12		Höhenmessgeräte, Anreißgeräte, Streichmaße, Zirkel, Reißnadeln Height gauges, Scribing instruments, Marking gauges, Dividers, Scribers	12
13		Bügel, Innen-, Tiefenmessschrauben, Einbaumessschrauben, Höhenmikrometer External / Internal / Depth micrometers, Micrometer heads, Height micrometer	13
14		Drehzahlmessgeräte, Zähler, Thermometer, Stoppuhren, Härteprüfer, Prüfgeräte Tachometers, Counters, Thermometers, Stop watches, Hardness testers, Test instruments	14
15		Waagen, Kraftmessgeräte, Lupen, Lupenleuchten Balances, Force measuring instruments, Magnifiers, Illuminated magnifiers	15



## ULTRA Germany Tradition, Präzision und Innovation seit über 125 Jahren

### Meilensteine einer Erfolgsgeschichte

#### 1888 Gründung von ULTRA

Die Anfänge gehen auf August Kirsch zurück, der in Aschaffenburg eine moderne Fabrik für Lehren und Messwerkzeuge gründete.



Prüfraum 1920  
Calibration lab 1920



Schleiferei 1920  
Grinding shop 1920

#### 1930 Übernahme durch Carl Jacob Kolb

Erstmals firmiert Carl Jacob Kolb mit „ULTRA PRÄZISIONSWERK ASCHAFFENBURG“, eine Bezeichnung, der er mit Energie und Weitblick gerecht wurde. Das Jahr 1888 gilt somit als Gründungsjahr von „ULTRA“ in Aschaffenburg.

#### 1955 Übernahme durch Schäfer (später FAG Kugelfischer)

Die Spezialisierung der Fertigung auf FAG spezifische Sonderanfertigungen führte dazu, dass das Kernprogramm „Messzeuge und Lehren“ etwas in den Hintergrund gedrängt wurde.

#### 1984 Übernahme durch Werner Bayer

Nach der Trennung von FAG folgte die Übernahme durch Werner Bayer, der das Unternehmen als ULTRA PRÄZISION MESSZEUGE GMBH weiterführt. Längensmesstechnik ist jetzt wieder das Kerngeschäft des Unternehmens. Durch Auslagerung der Produktion auf viele kleinere Fertigungsstätten, die zum großen Teil ihren Ursprung in der traditionellen Vergangenheit der Ur-Firma haben, entsteht in kürzester Zeit wieder ein bedeutendes Programm an hochwertigen Messzeugen und Lehren.

#### 1990 Nachfolgeregelung

Bereits im Alter von 25 Jahren tritt Stefan Bayer, der älteste Sohn von Werner Bayer, ins Unternehmen ein und kümmert sich fortan um den Vertrieb der ULTRA Produkte und das Produktmanagement.

## ULTRA Germany Tradition, precision and innovation for more than 125 years

### Milestones of a successful history

#### 1888 Foundation of ULTRA

The foundation stone was set by August Kirsch who established a modern factory for gauges and measuring tools in Aschaffenburg.

#### 1930 Take-over by Carl Jacob Kolb

Carl Jacob Kolb used the name „ULTRA PRÄZISIONSWERK ASCHAFFENBURG“ for the first time and he did justice to this designation due to his energy and vision. Thus the year 1888 is the official foundation year of „ULTRA“ in Aschaffenburg.



Firmengebäude 1930 – 1955  
Company building 1930 – 1955



ein Unternehmen der  
FAG Kugelfischer-  
Gruppe

#### 1955 Take-over by Schäfer (later on FAG Kugelfischer)

The specialisation of the production in FAG specific fields lead to the result that the core product range of measuring tools and gauges was pushed into the background.

#### 1984 Take-over by Werner Bayer

After the separation from FAG the company was taken over by Werner Bayer who re-founded it under the name ULTRA PRÄZISION MESSZEUGE GMBH. From that moment on metrology has become the core business of the company again. Due to the dislocation of production in several smaller manufacturing workshops, most part of them having their origin in the traditional past of the initial company, a considerable program of high-quality measuring tools and gauges could be created within a very short time.



Firmenbezeichnung seit 1984  
Company name since 1984

#### 1990 Succession policy

Stefan Bayer, the eldest son of Werner Bayer, joined the company already at the age of 25 years, and henceforth he took charge of the sales and of the marketing of the ULTRA products as well as of the product management.

## 1997 Neuer Firmensitz in Glattbach

Stetiges Wachstum erfordert eine größere Betriebsstätte. So entschied die Unternehmerfamilie „Bayer“ im Jahr 1997 den Grundstein für den neuen Firmensitz in Glattbach zu legen.

## 1997 New company's headquarters in Glattbach

Permanent growth required a larger establishment, therefore the family of entrepreneurs „Bayer“, decided to relocate the headstone in Glattbach, in the year 1997.

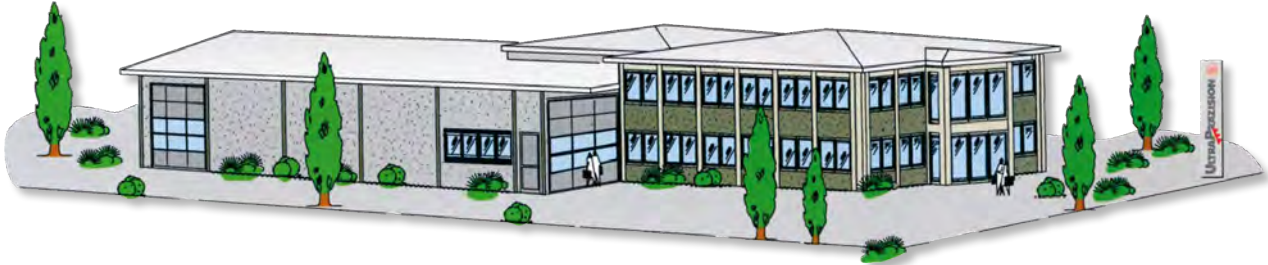

## 2004 Sonderlösungen werden zum Tagesgeschäft

Unter der Leitung von Stefan Bayer erfolgte eine neue Ausrichtung des Unternehmens, um auch die speziellen Bedarfsfälle unserer Kunden im Bereich der Sonderprüfmaschinen und des Sonderlehrenbaus zu erfüllen. ULTRA ist heute ein kompetenter Partner für alle Sonderlösungen rund um die Längenmesstechnik.

## 2004 Special solutions become day-to-day business

The company won a new orientation managed by Stefan Bayer, in order to be able to also fulfill special demands of the ULTRA customers in the field of special testing machines and of special-gauge construction. Nowadays ULTRA is a competent partner for all the metrology-related special solutions.

## 2012 Qualitätsmanagementsystem

Die neue DIN EN ISO 9001:2008 wird Grundlage unseres Qualitätsmanagementsystems. Auf Basis des PDCA – Zyklus gewährleistet ULTRA ausgezeichnete Prozesse und höchste Qualität.

## 2012 Quality Management System

The new DIN EN ISO 9001:2008 becomes the background of the ULTRA Quality Management System. ULTRA performs excellent processes and highest quality based on the PDCA cycle.



Ehrenurkunde, IHK Aschaffenburg  
Certificate of honour, Chamber of Commerce Aschaffenburg

## 2013 ULTRA 125-jähriges Jubiläum

Die IHK Aschaffenburg überreicht eine Ehrenurkunde zum Firmenjubiläum, um die unternehmerische Leistung und Beständigkeit zu würdigen. ULTRA hat sich auf dem Gebiet der Längenmesstechnik längst etabliert. Mit einem überdurchschnittlich hohen Exportanteil bedient ULTRA heute Kunden in über 100 Ländern weltweit.

## 2014 neuer Logistikbereich

Die Einhaltung höchster Qualitätsnormen sowie die termingerechte Lieferung unserer Produkte sind Grundvoraussetzung für eine hohe Kundenzufriedenheit. Unter der Leitung von Nelson Bayer wurden die Räumlichkeiten am Standort Glattbach zunächst analysiert und auf Basis der theoretisch optimierten Arbeitsabläufe ökonomisch eingerichtet.



Wellenmesszentrum  
Shaft measuring system

## 2013 ULTRA 125-year anniversary

On the occasion of the company's anniversary the Chamber of Commerce Aschaffenburg handed over a Certificate, as a sign of esteem for the entrepreneurial performance and steadiness. ULTRA has been well-established in the metrology field for a long time. With an above-average export share ULTRA supplies today customers in over 100 countries worldwide.

## 2014 New logistics area

Compliance with the highest quality standards and observance of the delivery deadlines are the prerequisite for a high customers satisfaction. Under the responsibility of Nelson Bayer the premises in the head office Glattbach were first analysed and then efficiently equipped, on the basis of the theoretically optimized work processes.

## 2016 Übernahme durch Stefan Bayer

Nach über 30 Jahren erfolgreicher Führung übergibt Werner Bayer das Unternehmen an seinen Sohn Stefan Bayer, der bereits seit 1990 als Prokurist für den Vertrieb und das Produktmanagement verantwortlich war. Stefan Bayer führt nun das Unternehmen als geschäftsführender Alleingesellschafter.

## 2016 take-over by Stefan Bayer

After more than 30 years of successful management Werner Bayer passed on the company to his son Stefan Bayer, which already had been authorized signatory in the sales and product management since 1990. Stefan Bayer leads the company as a managing director and sole owner now.

**ULTRA Messmittel sind heute weltweit bekannt, als Garant für höchste Präzision - made in Germany.**

Als Spezialist auf dem Gebiet der Längenmesstechnik bieten wir ein umfassendes Programm an hochwertigen Messzeugen und Lehren. Nutzen Sie unsere äußerst flexiblen Fertigungsstätten auch für alle Ihre zeichnungsgebundenen Sonderlehren, Präzisionsteile und Vorrichtungen - **fordern Sie uns als kompetenten Partner.**

**Today ULTRA measuring tools are known worldwide as a guarantor for highest precision made in Germany.**

As specialists in the metrology field we offer you a comprehensive product range of high-quality measuring tools and gauges. Do also take advantage of our extremely flexible manufacturing plants for all your special gauges, precision parts and devices according to your drawings - **do challenge us as your competitive partner.**

## ZERTIFIKAT DIN EN ISO 9001:2008

Zertifikat Reg. Nr. 10-5436813015

Unser Qualitätsmanagementsystem für die Herstellung und den Vertrieb von Messwerkzeugen, Lehren, Vorrichtungen sowie Präzisionsteilen entspricht den strengen Vorschriften der DIN EN ISO 9001:2008.

Grundlage unserer Qualitätssicherung ist der PDCA-Zyklus, welcher auf William Edwards Deming, einem Pionier im Bereich des Qualitätsmanagements, zurückzuführen ist. Nach Deming soll die ständige Verbesserung der qualitätsbestimmenden Faktoren durch das vier Phasen Modell des PDCA Zyklus (Plan-Do-Check-Act) entwickelt werden.

Ausschließlich Qualität ist verlässlich und hat Bestand. Wir leben Qualität, um Kundenzufriedenheit nachhaltig zu gewährleisten und weiterhin zu steigern.

Wir treffen ständig neue Maßnahmen zur Qualitätsverbesserung. Mit Hilfe diverser Methoden werden diese auf ihre Wirksamkeit überprüft, bewertet und sofern erforderlich, Korrekturmaßnahmen eingeleitet.

Durch Planung, Umsetzung, Kontrolle und Korrektur verbessert ULTRA permanent die qualitätsbestimmenden Prozesse. Hierdurch wird er ein gleichbleibend hoher Qualitätsstandard unserer Produkte gewährleistet.

Marcel Hollmann (QMB)

## CERTIFICATE DIN EN ISO 9001:2008

Certificate Reg. no. 10-5436813015

Our Quality Management System for the production and the sale of measuring tools, gauges, devices as well as for precision parts complies with the strict provisions of DIN EN ISO 9001:2008.

The basic concept of our quality assurance is the PDCA cycle created by William Edwards Deming, a pioneer in the field of quality management. According to Deming the steady improvement of the quality-determining factors must be developed by means of the four-stage model of the PDCA cycle (Plan-Do-Check-Act).

Only quality is reliable and can endure for the long term. We live for quality, in order to ensure the customers satisfaction in a sustainable way and to improve it further on.

We steadily take new measures for the quality improvement. By means of several methods they are checked and evaluated in regard of their efficiency, subsequent correcting actions shall be introduced as far as required.

ULTRA permanently improves the quality-determining processes by planning, implementation, control and correction. This ensures the constant high-quality standards of our products.

Marcel Hollmann (QM)

**ZERTIFIKAT**  
DIN EN ISO 9001

Die DGZmbH bescheinigt hiermit, dass das Unternehmen

**ULTRA PRÄZISION MESSZEUGE GMBH**  
Weitzkaut 3  
D-63864 Glattbach

**mit dem Geltungsbereich:**  
Herstellung und Vertrieb von Messwerkzeugen und Lehren, Vorrichtungen und Präzisionsteilen

ein Qualitätsmanagementsystem entsprechend der Norm DIN EN ISO 9001:2008 eingeführt hat und wirksam anwendet. Der Nachweis wurde im Rahmen des Audits mit der Berichtsnummer 08-829515415 erbracht. Die Zertifizierung bzw. das Zertifikat hat eine Gültigkeit von 3 Jahren, sofern die jährlichen Überwachungsaudits in den festgelegten Fristen mit positivem Ergebnis abgeschlossen werden.

Zertifizierungs-Nr.: 10-5436813015  
Ausstellungsdatum: 21.10.2015  
Gültig bis: 19.10.2018

*Marcel Hollmann*  
DGZmbH  
Deutsche Gesellschaft für Zertifizierung

**DGZ**  
Deutsche Gesellschaft für Zertifizierung

Dieses Dokument ist Eigentum der DGZmbH - Falkenberg 1 - 70764 Filderstadt - www.DGZmbH.eu

**ZERTIFIKAT**  
DIN EN ISO 9001

The Certification Body of DGZmbH hereby certifies that the company

**ULTRA PRÄZISION MESSZEUGE GMBH**  
Weitzkaut 3  
D-63864 Glattbach

**with the scope of:**  
Manufacturing and sale of measuring instruments and gauges, devices and precision parts

has introduced and effectively applied a quality management system according to DIN EN ISO 9001:2008. The proof was provided in the context with the audit with the report no. 08-829515415. The certificate or the certification is valid for 3 years, provided that the annual surveillance audits will be completed in the established deadlines with positive results.

Certificate Registration n°: 10-5436813015  
Date of first certification: 21.10.2015  
Valid until: 19.10.2018

*Marcel Hollmann*  
DGZ GmbH  
Deutsche Gesellschaft für Zertifizierung

**DGZ**  
Deutsche Gesellschaft für Zertifizierung

DGZ GmbH - Falkenberg 1 - 70764 Filderstadt - www.DGZmbH.eu

**ULTRA Kalibrierservice**

Qualitätsmanagementsysteme und Qualitätssicherungsnormen verlangen die regelmäßige Kalibrierung und Überwachung der betrieblich genutzten Messmittel.

**Werks-Kalibrierung**

Wir kalibrieren Lehren und Messmittel sowie Maßverkörperungen in Anlehnung an die Richtlinien VDI/VDE/DGQ 2618 Blatt 1–27 bzw. nach nationalen oder internationalen Normen. Die Rückführung auf nationale bzw. internationale Normale ist gewährleistet.



Prüfung eines Einstellings  
Calibration of setting ring gauge

**ULTRA calibration service**

Quality management systems and quality assurance standards require a regular calibration and supervision of the measuring tools used in the works.

**Works calibration**

We calibrate gauges and measuring tools as well as master gauges in conformity with the directives VDI/VDE/DGQ 2618 Sheets 1–27 and according to national and international standards respectively. The traceability to the national and international normal is assured.

**DAKKS-Kalibrierung**

Für einen großen Teil unserer Messmittel können DAKKS-Kalibrierscheine ausgestellt werden. Die Preise für diesen Service liegen nur geringfügig über den Konditionen der Werks-Kalibrierung. Das ausführende Labor ist Unterzeichner der „European Cooperation for Accreditation“ (EA) und der „International Laboratory Accreditation Cooperation“ (ILAC) zur gegenseitigen Anerkennung der Kalibrierscheine. Die Rückführung auf nationale Normale zur Darstellung der Einheiten in Übereinstimmung mit dem „Internationalen Einheitssystem“ (SI) ist somit gewährleistet.

Unsere aktuelle Preisliste für unseren Prüfmittelüberwachungs-Service senden wir Ihnen gerne zu. Preise für Messgeräte die nicht in unserer Standardliste enthalten sind, bitten wir gesondert anzufordern.



Werks-Kalibrierschein  
Works calibration report



DAKKS (DKD)-Kalibrierschein  
DAKKS (DKD) calibration report

**DAKKS calibration**

DAKKS calibration reports can be issued for a large part of our measuring instruments, the prices for this service only slightly exceed those for the works calibration. The performing laboratory is a signatory to the multilateral agreements of the "European Cooperation for Accreditation" (EA) and the "International Laboratory Accreditation Cooperation" (ILAC) for the mutual recognition of calibration certificates. The traceability to the national standards, realized with the units of measurement according to the "International System of Units" (SI) is ensured.

We would be pleased to send you our current net price list for our calibration service. Please ask separately for the calibration of measuring tools that are not included in our standard list.

**ULTRA Reparaturservice**

Die kostengünstige Alternative zum Neugerät. Wir reparieren Messgeräte und Lehren (auch Fremdfabrikate).

**Reparaturablauf:**

- » Analysieren der schadhaften Komponenten
- » Erstellen eines Kostenvoranschlags
- » Reparatur, mit fabrikneuen Ersatzteilen
- » Erstellen eines Kalibrierscheins, falls gewünscht
- » Rücklieferung zuzüglich Porto und Verpackung

Sollte eine wirtschaftliche Reparatur nicht mehr möglich sein erhalten Sie von uns natürlich ein Angebot für ein vergleichbares Neugerät. Bitte senden Sie Ihre Messmittel in geeigneter Verpackung frei Haus an unsere folgende Anschrift:



Einbau einer neuen Mikrometerspindel  
Mounting of a new micrometer spindle

**ULTRA repair service**

The economic alternative to new tools. We repair measuring tools and gauges, also products of other brands.

**Repair process:**

- » Analyse of damaged components
- » Elaboration of a cost estimate for release
- » Repair with brand-new replacement parts
- » Issue of calibration certificate, if required
- » The return shipment will be effected by adding freight and packing charges.

Should an economic repair not be possible anymore, you will certainly receive from us an offer for a new tool. Please send us your measuring tools in appropriated packing, freight prepaid, to the following address:

**ULTRA PRÄZISION MESSTZEUGE GMBH**  
Weitzkauf 3  
63864 Glattbach / Germany

**ULTRA PRÄZISION MESSTZEUGE GMBH**  
Weitzkauf 3  
63864 Glattbach / Germany

**ULTRA Hartgestein-Messplattenservice**

Wir vermessen Ihre Messplatten direkt bei Ihnen vorort und erstellen einen Werkskalibrierschein oder DAKKS-Kalibrierschein. Falls erforderlich werden die Messflächen gemäß DIN 876 oder nach Ihren ganz persönlichen Anforderungen nachgearbeitet.

**Ihre Vorteile:**

- Sie sparen hohe Verpackungs- und Transportkosten
- Es besteht kein Risiko der Beschädigung auf dem Transportweg
- Die Ausfallzeit Ihrer Messplatte ist minimal

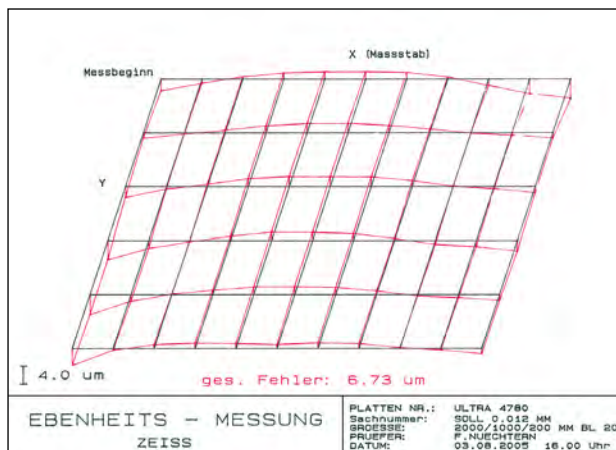

**ULTRA Granite measuring plate service**

We measure your measuring plates directly on your side and issue a works or DAKKS calibration certificate. If necessary the measuring surfaces are re-worked according to DIN 876, or according to your personalised requirements.

**Your advantages:**

- You save the high packing and transport costs
- No risk of damages in transit
- Minimum downtime for your measuring plate

**Pneumatische Kegelmessgeräte**  
Pneumatic taper gauges



**2.16**

**Einstellringe aus Keramik**  
Setting ring gauges, ceramic



**2.18**

**Universal Rachenlehren SNAPMATIC**  
Universal snap gauges SNAPMATIC



**2.22**

**Digital-Passameter**  
Digital Passameter



**2.23**

**Grenz-Gewindelehndorne aus Keramik**  
Limit thread plug gauges, ceramic



**3.8**

**Leitech Gewindeprüfdorne**  
Leitech thread plug gauge



**3.9**

**Messgeräte für Verzahnungsmessung**  
Measuring instrument for gear measurement



**3.13**

**Sylvac S\_Dial Work ADVANCED**  
Sylvac S\_Dial Work ADVANCED



**4.4**

**Fisso Messstativ STRATO-LINE**  
Fisso measuring stand STRATO-LINE



**5.3**

**Nutsymmetriemessgerät**  
Digital calipers for slot center distance measuring



**6.8**

**Digital-Innenfeinmessdorne MICROGAUGE**  
Digital precision bore gauges MICROGAUGE



**6.14**

**Vergleichsmessgeräte CARBON**  
Comparative measuring instrument CARBON



**6.38**

**Messplatten inkl. Schrankunterbau**  
Measuring plates incl. base tool cabinet



**7.11**

**Rundlaufprüfgeräte mit Abrollböcken**  
Concentricity testers with balancing stands

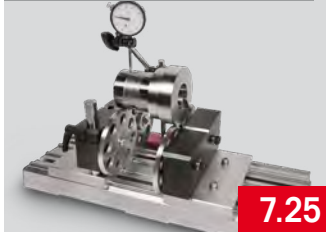

**7.25**

**Richtvorrichtung**  
Straightening tool



**7.25**

**Taschen-Rollbandmaße**  
Measuring tapes, pocket size



**9.11**

**Digital-Spaltmessgeräte**  
Digital caliper, step gauge



**9.18**

**Digital-Winkelmesser**  
Digital bevel protectors



**10.11**

**Digital-Universalmessschieber IP 67**  
Digital universal calipers IP 67



**11.17**

**Messschieber IP67, CABON**  
Calipers IP67, CARBON



**11.21**

**Messschrauben für Verzahnungsmessung**  
Micrometers for gear measurements



**13.23**

**Sondermessgeräte**  
Special measuring devices



**13.44**

**Digital-Härteprüfer**  
Digital hardness testers



**14.10**

**Ring-Lupenleuchte LED**  
Circular illuminated magnifiers LED



**15.17**



# 1

## Endmaße

Gauge blocks

## Endmaßzubehör

Gauge block accessories

## Plangläser

Optical flats

## Messkugeln

Measuring balls



### TOP

Parallel-Endmaßsätze aus Keramik  
Gauge block sets, ceramic



1.7

Planglasplatten  
Optical flats

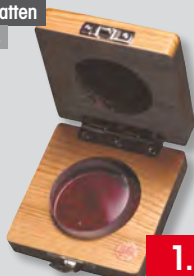

1.10

Kugellehren aus Hartmetall  
Ball gauges, tungsten carbide



1.12

Messkugelsätze  
Measuring ball sets

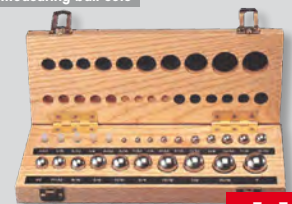

1.12



+49 (0) 60 21 42 999 00

1

2

3

4

5

6

7

8

9

10

11

12

13

14

15

## Gauge blocks DIN EN ISO 3650 (previously DIN 861)

### Genauigkeitsgrad und empfohlene Verwendung:

- Genauigkeit K** Urmaß als absolute Maßverkörperung im Feinmessraum.  
**Genauigkeit 0** zur Kontrolle von Messmitteln und zum Einstellen hochgenauer Messgeräte.  
**Genauigkeit 1** zur Kontrolle von Prüfmaßen, zum Einstellen von Messmitteln und als hochgenaues Arbeitsmaß.  
**Genauigkeit 2** Einstellmaß und Arbeitsmaß für die Fertigung.

**Querschnitt:** 0,5 – 10mm = 30x9mm  
 > 10mm = 35x9mm

### Materialeigenschaften im Vergleich: (Die Angaben sind ca. Werte)

Eigenschaften Properties	Stahl Steel	Hartmetall Tungsten carbide	Keramik Ceramic
Längenausdehnungskoeffizient Coefficient of expansion	$11 \pm 1 \times 10^{-6} / K^{-1}$	$4,6 \times 10^{-6} / K^{-1}$	$10 \pm 1 \times 10^{-6} / K^{-1}$
Wärmeleitfähigkeit Heat conductivity	hoch High	niedrig Low	sehr niedrig Very low
Härte Hardness	> 63 HRc	1450 – 1500 HV30	1350 HV
Verschleißfestigkeit Wear resistance	gut Good	sehr gut Very good	ausgezeichnet Excellent
Anschubeigenschaften Wringing characteristics	ausgezeichnet Excellent	gut Good	akzeptabel Acceptable
Geometrietreue Geometric fidelity	sehr gut bei korrekter Behandlung Very good with proper handling	ausgezeichnet Excellent	ausgezeichnet Excellent
Korrosionsbeständigkeit Corrosion resistance	weniger gut Satisfactory	gut Good	ausgezeichnet Excellent
Mechanische Festigkeit Mechanical stability	sehr gut Very good	gut Good	gut Good

### Accuracy grade and recommended use:

- Accuracy grade K** Primary standard as absolute master gauge in the laboratory  
**Accuracy grade 0** For testing measuring devices and setting up high-precision gauges  
**Accuracy grade 1** For testing check gauges, setting up measuring devices and as working dimension  
**Accuracy grade 2** Setting and working dimensions for production

**Cross section:** 0,5 – 10mm = 30x9mm  
 > 10mm = 35x9mm

### Material properties in comparison: (The data are approx. values)

### Zulässige Abweichungen und Toleranzen DIN EN ISO 3650:

te = zulässige Abweichung vom Nennmaß an beliebiger Stelle  
 tv = Toleranz für die Abweichungsspanne

### Permissible deviations and tolerances DIN EN ISO 3650:

te = Permissible deviation of nominal size at any position  
 tv = Tolerance for the deviation range

über / over bis / up to	mm		K		0		1		2	
	±te μ	tv μ	±te μ	tv μ	±te μ	tv μ	±te μ	tv μ	±te μ	tv μ
0	10	0,20	0,05	0,12	0,10	0,20	0,16	0,45	0,30	
10	25	0,30	0,05	0,14	0,10	0,30	0,16	0,60	0,30	
25	50	0,40	0,06	0,20	0,10	0,40	0,18	0,80	0,30	
50	75	0,50	0,06	0,25	0,12	0,50	0,18	1,00	0,35	
75	100	0,60	0,07	0,30	0,12	0,60	0,20	1,20	0,35	
100	150	0,80	0,08	0,40	0,14	0,80	0,20	1,60	0,40	
150	200	1,00	0,09	0,50	0,16	1,00	0,25	2,00	0,40	
200	250	1,20	0,10	0,60	0,16	1,20	0,25	2,40	0,45	
250	300	1,40	0,10	0,70	0,18	1,40	0,25	2,80	0,50	
300	400	1,80	0,12	0,90	0,20	1,80	0,30	3,60	0,50	
400	500	2,20	0,14	1,10	0,25	2,20	0,35	4,40	0,60	
500	600	2,60	0,16	1,30	0,25	2,60	0,40	5,00	0,70	
600	700	3,00	0,18	1,50	0,30	3,00	0,45	6,00	0,70	
700	800	3,40	0,20	1,70	0,30	3,40	0,50	6,50	0,80	
800	900	3,80	0,20	1,90	0,35	3,80	0,50	7,50	0,90	
900	1000	4,20	0,25	2,00	0,40	4,20	0,60	8,00	1,00	

### Kalibrierung:

Endmaße aus Stahl, Hartmetall und Keramik können mit einem Werkskalibrierschein oder DAkkS-Kalibrierschein eines akkreditierten Labors geliefert werden.

Bitte beachten Sie hierzu unsere Sonderpreise für Endmaßsätze inkl. DAkkS-Kalibrierschein oder Werkskalibrierschein. Die Bestellnummern sind in diesem Fall zusätzlich mit "p" gekennzeichnet.

Weitere Informationen erhalten Sie außerdem unter:  
[www.ultra-germany.com](http://www.ultra-germany.com) > Produkte > Service > Prüfmittelüberwachung

### Calibration:

Gauge blocks made of steel, tungsten carbide and ceramic can be delivered with a works calibration certificate or a DAkkS calibration certificate of an accredited laboratory.

Please note that our special prices for gauge block sets include the DAkkS or works calibration certificate. The order numbers are additionally marked with "p" in this case.

More information can be had at:  
[www.ultra-germany.com](http://www.ultra-germany.com) > Products > Service > Calibration

## Parallel-Endmaßsätze aus Spezialstahl, gehärtet Gauge block sets, hardened special steel



- ▶ DIN EN ISO 3650
- ▶ jedes Endmaß mit Nennmaß und Ident-Nr. signiert
- ▶ Lieferung im Holzetui

- ▶ DIN EN ISO 3650
- ▶ Each gauge block marked with nominal size and identity number
- ▶ Delivered in wooden box

**1006 410 – 1008 435 :**  
Sätze inkl. Herstellerkalibrierung

**1006 410 – 1008 435 :**  
Sets incl. manufacturer calibration

**1005 410p – 1008 435p :**  
Sätze inkl. DAkkS Kalibrierschein

**1005 410p – 1008 435p :**  
Sets incl. DAkkS calibration certificate



**!** Andere Satzzusammenstellungen auf Anfrage.

**!** Other set compositions on request.

Stück Pieces	mm	mm	kg	Ⓜ	Nº	Nº
32	1,005	-	1,2	K	-	1005 410p
	1,01 – 1,09	0,01		0	1006 410	1006 410p
	1,1 – 1,9	0,1		1	1007 410	1007 410p
	1,0 – 9,0	1,0		2	1008 410	1008 410p
	10/20/30/50	-				
47	1,005	-	1,5	K	-	1005 421p
	1,01 – 1,20	0,01		0	1006 421	1006 421p
	1,3 – 1,9	0,1		1	1007 421	1007 421p
	1,0 – 9,0	1,0		2	1008 421	1008 421p
	10 – 100	10,0				
87	1,001 – 1,009	0,001	3,5	K	-	1005 431p
	1,01 – 1,49	0,01		0	1006 431	1006 431p
	0,5 – 9,5	0,5		1	1007 431	1007 431p
	10 – 100	10,0		2	1008 431	1008 431p
103	1,005	-	4,3	K	-	1005 435p
	1,01 – 1,49	0,01		0	1006 435	1006 435p
	0,5 – 24,5	0,5		1	1007 435	1007 435p
	25 – 100	25,0		2	1008 435	1008 435p
112	1,0005	-	3,8	0	1006 440	1006 440p
	1,001 – 1,009	0,001		1	1007 440	1007 440p
	1,01 – 1,49	0,01				
	0,5 – 24,5	0,5				
122	1,0005	-	4,2	0	1006 445	1006 445p
	1,001 – 1,009	0,001		1	1007 445	1007 445p
	1,01 – 1,49	0,01				
	0,5/1,0/1,5 – 1,9	0,1				
	2 – 25	0,5				
30 – 100	10					
75	-					

## Parallel-Endmaßsätze aus Spezialstahl, gehärtet Gauge block sets, hardened special steel



- ▶ DIN EN ISO 3650
- ▶ jedes Endmaß mit Nennmaß und Ident-Nr. signiert
- ▶ ab 125mm mit Verbindungslöchern
- ▶ Lieferung im Holzetui

- ▶ DIN EN ISO 3650
- ▶ Each gauge block marked with nominal size and identity number
- ▶ from 125mm with clamping holes
- ▶ Delivered in wooden box

**1006 446 – 1007 450 :**  
Sätze ohne Kalibrierschein

**1006 446 – 1007 450 :**  
Sets without calibration certificate

**1006 446p – 1007 447p :**  
Sätze inkl. DAkkS Kalibrierschein

**1006 446p – 1007 447p :**  
Sets incl. DAkkS calibration certificate

**1006 450p – 1007 450p :**  
Sätze inkl. Werkkalibrierschein eines akkreditierten Labors

**1006 450p – 1007 450p :**  
Sets incl. works calibration certificate of an accredited laboratory



**!** Andere Satzzusammenstellungen sowie Genauigkeit K auf Anfrage.

**!** Other set compositions as well as accuracy grade K on request.

Stück Pieces	mm	kg	Ⓜ	Nº	Nº
9	1,001 / 1,002 / 1,003 / 1,004 / 1,005 / 1,006 / 1,007 / 1,008 / 1,009	0,5	0	1006 446	1006 446p
			1	1007 446	1007 446p
9	0,991 / 0,992 / 0,993 / 0,994 / 0,995 / 0,996 / 0,997 / 0,998 / 0,999	0,5	0	1006 447	1006 447p
			1	1007 447	1007 447p
8	125 / 150 / 175 / 200 / 250 / 300 / 400 / 500	7,0	0	1006 450	1006 450p
			1	1007 450	1007 450p

## Parallel-Endmaßsätze aus Spezialstahl, gehärtet Gauge block sets, hardened special steel



**Gehärtet  
Hardened**

- ▶ DIN EN ISO 3650
- ▶ zum Prüfen von Messschrauben nach VDI/VDE/DGQ/2618
- ▶ jedes Endmaß mit Nennmaß und Ident-Nr. signiert
- ▶ Lieferung im Holzetui

- ▶ DIN EN ISO 3650
- ▶ For checking micrometers according to VDI/VDE/DGQ/2618
- ▶ Each gauge block marked with nominal size and identity number
- ▶ Delivered in wooden box

**1007 470 – 1007 475 :**  
Sätze ohne Kalibrierschein

**1007 470 – 1007 475 :**  
Sets without calibration certificate

**1007 470p – 1007 475p :**  
Sätze inkl. DAkKS Kalibrierschein

**1007 470p – 1007 475p :**  
Sets incl. DAkKS calibration certificate

Stück Pieces	mm	kg	Ⓢ	Nº	Nº
10	2,5 / 5,1 / 7,7 / 10,3 / 12,9 / 15 / 17,6 / 20,2 / 22,8 / 25	0,7	1	1007 470	1007 470p
5	5,1 / 10,3 / 15,0 / 20,2 / 25,0	0,6	1	1007 474	1007 474p
8	5,1 / 10,3 / 15,0 / 20,2 / 25,0 / 50 / 75 / 100	0,9	1	1007 475	1007 475p
Klemmhalter im Etui für 10 Stück Endmaße / Holder in box for 10 pcs. gauges blocks				<b>1003 801</b>	



Endmaßsätze aus Keramik siehe Kat. Seite 1.7  
Gauge block sets, ceramic see cat. page 1.7

## Parallel-Endmaßsätze aus Spezialstahl, gehärtet Gauge block sets, hardened special steel



**Gehärtet  
Hardened**

- ▶ DIN EN ISO 3650
- ▶ zum Prüfen von Messschiebern und Höhenreißern nach VDI/VDE/DGQ 2618
- ▶ jedes Endmaß mit Nennmaß und Ident-Nr. signiert
- ▶ Lieferung im Holzetui

- ▶ DIN EN ISO 3650
- ▶ For checking calipers and marking gauges according to VDI/VDE/DGQ 2618
- ▶ Each gauge block marked with nominal size and identity number
- ▶ Delivered in wooden box

**1007 480 – 1007 484 :**  
Sätze ohne Kalibrierschein

**1007 480 – 1007 484 :**  
Sets without calibration certificate

**1007 480p – 1007 484p :**  
Sätze inkl. Werkskalibrierschein eines akkreditierten Labors.

**1007 480p – 1007 484p :**  
Sets incl. works calibration certificate of an accredited laboratory.

Stück Pieces	mm	kg	Ⓢ	Nº	Nº
3	30,0 / 41,3 / 131,4	0,6	1	1007 480	1007 480p
4	30,0 / 41,3 / 131,4 / 243,5	1,4	1	1007 481	1007 481p
5	30,0 / 41,3 / 131,4 / 243,5 / 281,2	2,0	1	1007 482	1007 482p
6	30,0 / 41,3 / 131,4 / 243,5 / 281,2 / 481,1	4,0	1	1007 483	1007 483p
8	30,0 / 41,3 / 131,4 / 243,5 / 281,2 / 481,1 / 550 / 700,0	10,0	1	1007 484	1007 484p



No. 1007 480

Endmaßsätze aus Keramik siehe Kat. Seite 1.7  
Gauge block sets, ceramic see cat. page 1.7

## Einstellringsatz aus Spezialstahl, gehärtet Setting ring gauge set, hardened special steel



**Gehärtet  
Hardened**

- ▶ DIN 2250 C
- ▶ zum Prüfen von Messschieber nach VDI/VDE/DGQ/2618
- ▶ jeder Ring mit Nennmaß und Ident-Nr. signiert
- ▶ Lieferung im Holzetui

- ▶ DIN 2250 C
- ▶ For checking calipers according to VDI/VDE/DGQ/2618
- ▶ Each ring marked with nominal size and identity number
- ▶ Delivered in wooden box

**1007 490 :**  
Satz ohne Kalibrierschein

**1007 490 :**  
Set without certificate

**1007 490p :**  
Satz inkl. Werkskalibrierschein eines akkreditierten Labors

**1007 490p :**  
Set incl. works calibration certificate of an accredited laboratory

Stück Pieces	Ø mm	kg	Nº	Nº
2	4 / 25	0,3	1007 490	1007 490p



No. 1007 490

## Parallel-Einzelendmaße aus Spezialstahl, gehärtet Gauge block singles, hardened special steel



- ▶ DIN EN ISO 3650
- ▶ jedes Endmaß mit Nennmaß und Ident-Nr. signiert
- ▶ ab 125mm mit Verbindungslöchern
- ▶ Lieferung ab Nennmaß 125mm im Holzetui

- ▶ DIN EN ISO 3650
- ▶ Each gauge block marked with nominal size and identity number
- ▶ from 125mm with clamping holes
- ▶ Delivered in wooden box > 125mm

**1000 101-0 – 1000 295-0 :**  
Genauigkeit 0

**1000 101-0 – 1000 295-0 :**  
Accuracy grade 0

**1000 101-1 – 1000 295-1 :**  
Genauigkeit 1

**1000 101-1 – 1000 295-1 :**  
Accuracy grade 1

**1000 101-2 – 1000 295-2 :**  
Genauigkeit 2

**1000 101-2 – 1000 295-2 :**  
Accuracy grade 2



**I** Sonderabmessungen und Genauigkeit K auf Anfrage.

**I** Special dimensions and accuracy grade K on request.

mm	mm	0 Nº	1 Nº	2 Nº
0,5	-	1000 101-0	1000 101-1	1000 101-2
1,0	-	1000 130-0	1000 130-1	1000 130-2
1,0005	-	1000 132-0	1000 132-1	1000 132-2
1,001 – 1,009	0,001	1000 131-0	1000 131-1	1000 131-2
1,01 – 1,49	0,01	1000 141-0	1000 141-1	1000 141-2
1,50 – 1,90	0,1	1000 201-0	1000 201-1	1000 201-2
2,00 – 5,00	0,5	1000 211-0	1000 211-1	1000 211-2
5,50 – 10,00	0,5	1000 221-0	1000 221-1	1000 221-2
10,50 – 15,00	0,5	1000 231-0	1000 231-1	1000 231-2
15,50 – 20,00	0,5	1000 232-0	1000 232-1	1000 232-2
20,50 – 25,00	0,5	1000 235-0	1000 235-1	1000 235-2
30,00	-	1000 271-0	1000 271-1	1000 271-2
40,00	-	1000 272-0	1000 272-1	1000 272-2
50,00	-	1000 273-0	1000 273-1	1000 273-2
60,00	-	1000 274-0	1000 274-1	1000 274-2
70,00	-	1000 275-0	1000 275-1	1000 275-2
75,00	-	1000 276-0	1000 276-1	1000 276-2
80,00	-	1000 277-0	1000 277-1	1000 277-2
90,00	-	1000 278-0	1000 278-1	1000 278-2
100,00	-	1000 279-0	1000 279-1	1000 279-2
125,00	-	1000 280-0	1000 280-1	1000 280-2
150,00	-	1000 281-0	1000 281-1	1000 281-2
175,00	-	1000 282-0	1000 282-1	1000 282-2
200,00	-	1000 283-0	1000 283-1	1000 283-2
250,00	-	1000 284-0	1000 284-1	1000 284-2
300,00	-	1000 285-0	1000 285-1	1000 285-2
350,00	-	1000 286-0	1000 286-1	1000 286-2
400,00	-	1000 287-0	1000 287-1	1000 287-2
450,00	-	1000 288-0	1000 288-1	1000 288-2
500,00	-	1000 289-0	1000 289-1	1000 289-2
550,00	-	1000 290-0	1000 290-1	1000 290-2
600,00	-	1000 291-0	1000 291-1	1000 291-2
700,00	-	1000 292-0	1000 292-1	1000 292-2
800,00	-	1000 293-0	1000 293-1	1000 293-2
900,00	-	1000 294-0	1000 294-1	1000 294-2
1000,00	-	1000 295-0	1000 295-1	1000 295-2

## Endmaßverbinder Gauge block connector

- ▶ zum Verbinden langer Endmaße
- ▶ Lieferung einzeln verpackt

- ▶ For connecting long gauge blocks
- ▶ Delivered in individual packages

**1003 105 :**  
verbindet 2 Endmaße

**1003 105 :**  
Connects 2 gauge blocks

**1003 205 :**  
verbindet eine individuelle Maßkombination (0 – 90mm) zwischen 2 Endmaßen

**1003 205 :**  
Connects an individual size combination (0 – 90mm) between 2 gauge blocks

für / for mm	l. mm	kg	Nº
>100	72x30x30	0,25	1003 105
>100	135x30x30	0,45	1003 205

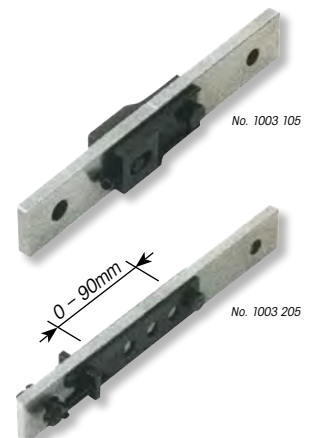

## Parallel-Endmaßsätze aus Hartmetall

## Gauge block sets, tungsten carbide



**Hartmetall  
Tungsten carbide**



No. 1012 410

- ▶ DIN EN ISO 3650
- ▶ jedes Endmaß mit Nennmaß und Ident-Nr. signiert
- ▶ Lieferung im Holzetui

- ▶ DIN EN ISO 3650
- ▶ Each gauge block marked with nominal size and identity number
- ▶ Delivered in wooden box

**1011 410 – 1012 435 :**  
Sätze inkl. Herstellerkalibrierung

**1011 410 – 1012 435 :**  
Sets incl. manufacturer calibration

**1010 410p – 1012 435p :**  
Sätze inkl. Werkskalibrierschein eines akkreditierten Labors.

**1010 410p – 1012 435p :**  
Sets incl. works calibration certificate of an accredited laboratory

! Andere Satzzusammenstellungen auf Anfrage.

! Other set compositions on request.

Stück Pieces	mm	mm	kg	Ⓚ	Nº	Nº	Stück Pieces	mm	mm	kg	Ⓚ	Nº	Nº			
32	1,005	-	1,2	K	-	1010 410p	103	1,005	-	4,3	K	-	1010 435p			
	1,01 – 1,09	0,01						1,01 – 1,49	0,01					0	1011 410	1011 435p
	1,1 – 1,9	0,1						0,5 – 24,5	0,5					1	1012 410	1012 435p
	1,0 – 9,0	1,0						25 – 100	25,0					1	1012 435	1012 435p
10/20/30/50	-															
47	1,005	-	1,5	K	-	1010 421p	112	1,0005	-	4,4	0	1011 440	1011 440p			
	1,01 – 1,20	0,01						1,01 – 1,09	0,001					0	1011 421	1011 421p
	1,3 – 1,9	0,1						1,01 – 1,49	0,01					1	1012 421	1012 421p
	1,0 – 9,0	1,0						0,5 – 24,5	0,5					1	1012 440	1012 440p
10 – 100	10	25 – 100	25													
87	1,001 – 1,009	0,001	3,5	K	-	1010 431p	122	1,0005	-	4,5	0	1011 445	1011 445p			
	1,01 – 1,49	0,01						1,001 – 1,009	0,001					0	1011 431	1011 431p
	0,5 – 9,5	0,5						1,01 – 1,49	0,01					1	1012 445	1012 445p
	10 – 100	10,0						0,5/1,0/1,5 – 1,9	0,1					1	1012 445	1012 445p
								2 – 25	0,5							
								30 – 100	10							
								75	-							

## Parallel-Einzelendmaße aus Hartmetall

## Gauge block singles, tungsten carbide



**Hartmetall  
Tungsten carbide**



No. 1001...

- ▶ DIN EN ISO 3650
- ▶ jedes Endmaß mit Nennmaß und Ident-Nr. signiert
- ▶ Lieferung einzeln verpackt

- ▶ DIN EN ISO 3650
- ▶ Each gauge block marked with nominal size and identity number
- ▶ Delivered in individual packages

**1001 101-0 – 1001 279-0 :**  
Genauigkeit 0

**1001 101-0 – 1001 279-0 :**  
Accuracy grade 0

**1001 101-1 – 1001 279-1 :**  
Genauigkeit 1

**1001 101-1 – 1001 279-1 :**  
Accuracy grade 1

**1001 101-2 – 1001 279-2 :**  
Genauigkeit 2

**1001 101-2 – 1001 279-2 :**  
Accuracy grade 2

! Sonderabmessungen und Genauigkeit K auf Anfrage.

! Special dimensions and accuracy grade K on request.

mm	mm	Ⓚ 0 Nº	Ⓚ 1 Nº	Ⓚ 2 Nº	mm	mm	Ⓚ 0 Nº	Ⓚ 1 Nº	Ⓚ 2 Nº
0,5	-	1001 101-0	1001 101-1	1001 101-2	20,50 – 25,00	0,5	1001 235-0	1001 235-1	1001 235-2
1,0	-	1001 130-0	1001 130-1	1001 130-2	30,00	-	1001 271-0	1001 271-1	1001 271-2
1,0005	-	1001 132-0	1001 132-1	1001 132-2	40,00	-	1001 272-0	1001 272-1	1001 272-2
1,001 – 1,009	0,001	1001 131-0	1001 131-1	1001 131-2	50,00	-	1001 273-0	1001 273-1	1001 273-2
1,01 – 1,49	0,01	1001 141-0	1001 141-1	1001 141-2	60,00	-	1001 274-0	1001 274-1	1001 274-2
1,50 – 1,90	0,1	1001 201-0	1001 201-1	1001 201-2	70,00	-	1001 275-0	1001 275-1	1001 275-2
2,00 – 5,00	0,5	1001 211-0	1001 211-1	1001 211-2	75,00	-	1001 276-0	1001 276-1	1001 276-2
5,50 – 9,50	0,5	1001 221-0	1001 221-1	1001 221-2	80,00	-	1001 277-0	1001 277-1	1001 277-2
10,00 – 15,00	0,5	1001 231-0	1001 231-1	1001 231-2	90,00	-	1001 278-0	1001 278-1	1001 278-2
15,50 – 20,00	0,5	1001 232-0	1001 232-1	1001 232-2	100,00	-	1001 279-0	1001 279-1	1001 279-2

**Parallel-Endmaßsätze aus Keramik**

**Gauge block sets, ceramic**



**Keramik Ceramic**

- ▶ DIN EN ISO 3650
- ▶ jedes Endmaß mit Nennmaß und Ident-Nr. signiert
- ▶ Lieferung im Holzetui

- ▶ DIN EN ISO 3650
- ▶ Each gauge block marked with nominal size and identity number
- ▶ Delivered in wooden box



No. 1015 435

**1016 410 – 1017 480 :**  
Sätze inkl. Herstellerkalibrierung

**1016 410 – 1017 480 :**  
Sets incl. manufacturer calibration

**1015 410p – 1017 480p :**  
Sätze inkl. DAkkS Kalibrierschein

**1015 410p – 1017 480p :**  
Sets incl. DAkkS calibration certificate

**!** Andere Satzzusammenstellungen auf Anfrage.

**!** Other set compositions on request.

Stück Pieces	mm	mm	kg	Ⓢ	Nº	Nº	Stück Pieces	mm	mm	kg	Ⓢ	Nº	Nº		
32	1,005	-	1,2	K	-	1015 410p	112	1,0005	-	4,4	0	1016 440	1016 440p		
	1,01 – 1,09	0,01		O	1016 410	1016 410p									
	1,1 – 1,9	0,1		1	1017 410	1017 410p									
	1,0 – 9,0	1,0													
10/20/30/50	-														
47	1,005	-	1,5	K	-	1015 421p	122	1,0005	-	4,5	0	1016 445	1016 445p		
	1,01 – 1,20	0,01		O	1016 421	1016 421p									
	1,3 – 1,9	0,1		1	1017 421	1017 421p									
	1,0 – 9,0	1,0													
10 – 100	10														
87	1,001 – 1,009	0,001	3,5	K	-	1015 431p	Satz zum Prüfen von Messschrauben / Set for checking micrometers								
	1,01 – 1,49	0,01		O	1016 431	1016 431p	10	2,5 / 5,1 / 7,7 / 10,3 / 12,9 / 15 / 17,6 / 20,2 / 22,8 / 25	0,7	1	1017 470	1017 470p			
	0,5 – 9,5	0,5		1	1017 431	1017 431p									
	10 – 100	10,0													
103	1,005	-	4,3	K	-	1015 435p	Satz zum Prüfen von Messschiebern / Set for checking calipers								
	1,01 – 1,49	0,01		O	1016 435	1016 435p	3	30 / 41,3 / 131,4	0,6	1	1017 480	1017 480p			
	0,5 – 24,5	0,5		1	1017 435	1017 435p									
	25 – 100	25,0													

**Parallel-Einzelendmaße aus Keramik**

**Gauge block singles, ceramic**



**Keramik Ceramic**

- ▶ DIN EN ISO 3650
- ▶ jedes Endmaß mit Nennmaß und Ident-Nr. signiert
- ▶ Lieferung einzeln verpackt

- ▶ DIN EN ISO 3650
- ▶ Each gauge block marked with nominal size and identity number
- ▶ Delivered in individual packages



No. 1002 ...

**1002 101-0 – 1002 279-0 :**  
Genauigkeit 0

**1002 101-0 – 1002 279-0 :**  
Accuracy grade 0

**1002 101-1 – 1002 279-1 :**  
Genauigkeit 1

**1002 101-1 – 1002 279-1 :**  
Accuracy grade 1

**1002 101-2 – 1002 279-2 :**  
Genauigkeit 2

**1002 101-2 – 1002 279-2 :**  
Accuracy grade 2

**!** Sonderabmessungen und Genauigkeit K auf Anfrage.

**!** Special dimensions and accuracy grade K on request.

mm	mm	Ⓢ 0 Nº	Ⓢ 1 Nº	Ⓢ 2 Nº	mm	mm	Ⓢ 0 Nº	Ⓢ 1 Nº	Ⓢ 2 Nº
0,5	-	1002 101-0	1002 101-1	1002 101-2	20,50 – 25,00	0,5	1002 235-0	1002 235-1	1002 235-2
1,0	-	1002 130-0	1002 130-1	1002 130-2	30,00	-	1002 271-0	1002 271-1	1002 271-2
1,0005	-	1002 132-0	1002 132-1	1002 132-2	40,00	-	1002 272-0	1002 272-1	1002 272-2
1,001 – 1,009	0,001	1002 131-0	1002 131-1	1002 131-2	50,00	-	1002 273-0	1002 273-1	1002 273-2
1,01 – 1,49	0,01	1002 141-0	1002 141-1	1002 141-2	60,00	-	1002 274-0	1002 274-1	1002 274-2
1,50 – 1,90	0,1	1002 201-0	1002 201-1	1002 201-2	70,00	-	1002 275-0	1002 275-1	1002 275-2
2,00 – 5,00	0,5	1002 211-0	1002 211-1	1002 211-2	75,00	-	1002 276-0	1002 276-1	1002 276-2
5,50 – 9,50	0,5	1002 221-0	1002 221-1	1002 221-2	80,00	-	1002 277-0	1002 277-1	1002 277-2
10,00 – 15,00	0,5	1002 231-0	1002 231-1	1002 231-2	90,00	-	1002 278-0	1002 278-1	1002 278-2
15,50 – 20,00	0,5	1002 232-0	1002 232-1	1002 232-2	100,00	-	1002 279-0	1002 279-1	1002 279-2

## Winkel-Endmaßsatz aus Spezialstahl, gehärtet / Angle gauge block set, hardened special steel



**Gehärtet  
Hardened**

- ▶ Werksnorm
- ▶ Toleranz  $\pm 30''$
- ▶ kleinste Stufung 15' (1/4°)
- ▶ Breite 6,35mm, Länge 76,4mm
- ▶ Lieferung im Etui

- ▶ Works standard
- ▶ Tolerance  $\pm 30''$
- ▶ Smallest step 15' (1/4°)
- ▶ Width 6.35mm; length 76.4mm
- ▶ Delivery in a case



No. 1020 203

**I** Andere Satzzusammenstellung sowie höhere Genauigkeit auf Anfrage.

**I** Other set compositions and higher accuracy grades on request.

Stück Pieces		kg	Nº
12	15' / 30' / 1° / 2° / 3° / 4° / 5° / 10° / 15° / 20° / 25° / 30°	1,2	1020 203

## Isoliergriffe / Insulating handles



- ▶ zum Schutz vor Erwärmung beim Halten von Parallel-Endmaßen
- ▶ Lieferung einzeln verpackt

- ▶ For protection against heating when handling the gauge blocks
- ▶ Delivered in individual packages



No. 1003 102

No. 1003 101

für / for mm	l. mm	kg	Nº
<150	155x50x20	0,15	1003 102
>150	140x55x28	0,15	1003 101

## Abziehstein / Deburring stone



- ▶ zum Entfernen von Grat an den Messflächen und an den Kanten der Endmaße
- ▶ geeignet für Endmaße aus Stahl, Hartmetall und Keramik
- ▶ Lieferung einzeln verpackt

- ▶ For removing burr from the measuring faces and edges of the gauge block
- ▶ Suitable for gauge blocks made of steel, tungsten carbide and ceramic
- ▶ Delivered in individual packages



No. 1003 103

l. mm	kg	Nº
50x25x10	0,05	1003 103
100x25x10	0,10	1003 203

## Korrosions-Schutzöl / Anti-corrosion oil



- ▶ zum Konservieren von Stahl-Endmaßen
- ▶ Lieferung in Kunststoffflasche

- ▶ For conservation of steel gauge blocks
- ▶ Delivered in plastic bottles



No. 1003 104

ccm	kg	Nº
50	0,06	1003 104

## Endmaßpflegekasten-Satz / Service kit-sets



- ▶ Inhalt:  
Leinentuch, Wildledertuch, Haarpinsel, Fettpinsel  
Pflegeanweisung
- ▶ Abziehstein Nr. 1003 103
- ▶ Korrosions-Schutzöl Nr. 1003 104
- ▶ Lieferung im Holzetui

- ▶ Contents:  
Linen cloth, Suede leather mat, Soft and grease brushes,  
Instructions for care
- ▶ Deburring stone, ref. no. 1003 103
- ▶ Anti-corrosion oil, ref. no. 1003 104
- ▶ Delivered in a wooden case



No. 1051 101

l. mm	kg	Nº
170x140x55	0,7	1051 101



**Endmaßzubehör-Sätze**

**Gauge block accessories-sets**

- ▶ Werksnorm
- ▶ erweitern die Anwendungsmöglichkeiten von Parallelendmaßen
- ▶ Lieferung im Holzetui

- ▶ Works standard
- ▶ Widens the range of application of gauge blocks
- ▶ Delivered in wooden box

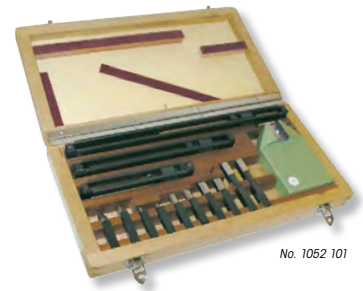

No. 1052 101

**1052 101 :**  
Inhalt:  
- je 1 Halter mit Schnellverstellung 0-50 / 0-100 / 100-200mm  
- je 1 Paar Messschnäbel Ø 4 / 10 / 16 / 20mm  
- 1 Zentrierspitze  
- 1 Anreißspitze  
- 1 Standfuß

**1052 101 :**  
Contents:  
- 1 holder with quick adjustment 0-50 / 0-100 / 100-200mm each  
- 1 pair measuring jaws Ø 4 / 10 / 16 / 20mm each  
- 1 Centre point  
- 1 Scriber point  
- 1 Base

 **1052 101s :**  
Inhalt:  
- je 1 Halter mit Standardklemmung 0-50 / 0-100 / 100-200mm  
- je 1 Paar Messschnäbel Ø 4 / 10 / 20mm  
- 1 Zentrierspitze  
- 1 Anreißspitze  
- 1 Standfuß

**1052 101s :**  
Contents:  
- 1 holder with standard clamping 0-50 / 0-100 / 100-200 mm each  
- 1 pair measuring jaws Ø 4 / 10 / 20mm each  
- 1 Centre point  
- 1 Scriber point  
- 1 Base



No. 1052 101s

 Andere Satzzusammenstellungen auf Anfrage.

 Other set compositions on request.

Stück Pieces	kg	Nº
10	3,0	1052 101
9	3,2	1052 101s

Anwendungsbeispiele:  
Examples of use:

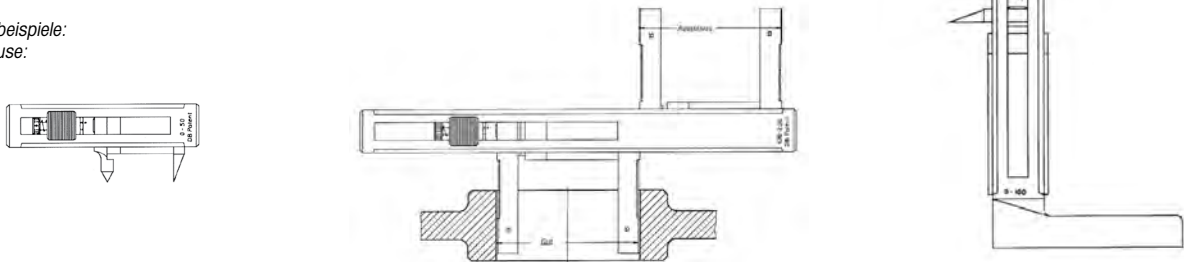

**Endmaßhalter mit Schnellverstellung**

**Gauge block holder with quick adjustment**



- ▶ zum Klemmen von Endmaßkombinationen und Zubehör
- ▶ mit Schnellverstellung passend zu Satz Nr. 1052 101
- ▶ Lieferung einzeln verpackt

- ▶ For clamping gauge block combinations and accessories
- ▶ With quick adjustment suitable for set no. 1052 101
- ▶ Delivered in individual packages



No. 1055 1..

für / for -■- mm	kg	Nº
0 - 50	0,2	1055 101
0 - 100	0,3	1055 102
0 - 200	0,4	1055 103
100 - 200	0,4	1055 104
100 - 300	0,5	1055 105
200 - 400	0,6	1055 106
300 - 500	0,7	1055 107
500 - 800	1,0	1055 108
800 - 1000	1,2	1055 109
1000 - 1200	1,4	1055 110
1000 - 1500	1,6	1055 111
1500 - 2000	1,8	1055 112
Standfuß / Base	1,0	1054 101

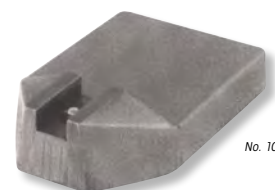

No. 1054 101

1  
2  
3  
4  
5  
6  
7  
8  
9  
10  
11  
12  
13  
14  
15

## Halbrunde Messschenkelpaare

## Half round jaw (pair)



**Gehärtet  
Hardened**

- ▶ Werksnorm
- ▶ Innen- und Außenmessungen
- ▶ Zylindrische Messflächen
- ▶ Spezialstahl gehärtet
- ▶ Lieferung paarweise verpackt

- ▶ Works standard
- ▶ Inner and outer measurements
- ▶ Measuring faces cylindrical
- ▶ Hardened special steel
- ▶ Delivered in a package (pair)

**I** Größere Durchmesser auf Anfrage.

**I** Larger diameters on request.

Ø mm	a mm	⚖ kg	Nº
4 (R2)	8	0,03	1056 101
10 (R5)	15	0,05	1056 102
16 (R8)	20	0,07	1056 103
20 (R10)	40	0,1	1056 104

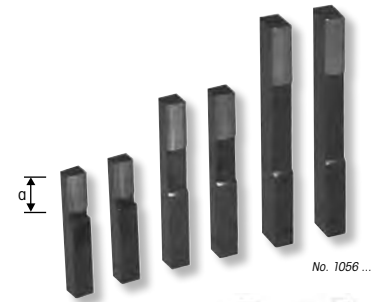

Anwendungsbeispiel:  
Example of use:

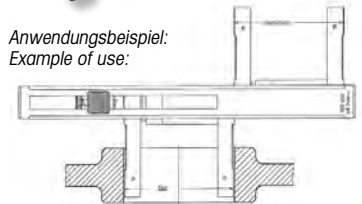

## Plane Messschenkelpaare

## Flat jaw (pair)



**Gehärtet  
Hardened**

- ▶ Werksnorm
- ▶ Spezialstahl gehärtet
- ▶ Lieferung paarweise verpackt

- ▶ Works standard
- ▶ Hardened special steel
- ▶ Delivered in a package (pair)

**1057 1..**  
nur Außenmessung

**1057 1..**  
Only for outer measurement

**1058 1..**  
Innen und Außenmessung

**1058 1..**  
Inner and outer measurements

l mm	b mm	⚖ kg	Nº	Nº
100	20x9	0,2	1057 101	1058 101
125	20x9	0,25	1057 102	1058 102



Anwendungsbeispiele:  
Example of use:

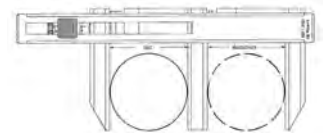

## Planglasplatten

## Optical flats



- ▶ Werksnorm
- ▶ zur Ebenheitsprüfung von Messflächen nach dem Interferenzverfahren
- ▶ Lieferung im Etui

- ▶ Works standard
- ▶ For checking flatness of the measuring faces according to the interference process
- ▶ Delivered in a case

**I** Größere Durchmesser auf Anfrage.

**I** Larger diameters on request.

Ø mm	h mm	∠ μ	⚖ kg	Nº
35	10	0,1	0,13	1050 101
50	15	0,1	0,15	1050 102
65	20	0,1	0,26	1050 103
70	20	0,1	0,33	1050 104
100	20	0,1	0,85	1050 105
125	25	0,1	1,0	1050 106
150	25	0,1	1,5	1050 107
200	35	0,1	2,0	1050 108

≥ 200mm auf Anfrage / on request

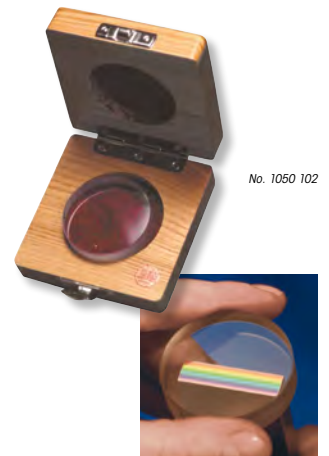

Prüfglassätze für Bügelmessschrauben siehe Kat. S. 13.14  
Optical parallel sets for micrometers please see cat. page 13.14

**Einstellgeräte CARBON  
für Innenfeinmessgeräte**

**Setting instruments CARBON  
for bore gauges**



- ▶ Werksnorm
- ▶ Führungssäule aus doppeltem Kohlefaserprofil, Führungselemente aus verchromtem Stahl
- ▶ horizontal und vertikal einsetzbar
- ▶ Nennmaß wird durch Endmaße eingestellt
- ▶ Einstellbacken gehärtet
- ▶ Lieferung im Etui, ohne Endmaße

- ▶ Works standard
- ▶ Double carbon fibre bar guiding elements made of chrome steel
- ▶ Horizontal and vertical application
- ▶ Nominal sizes adjusted with gauge blocks
- ▶ Setting jaws, hardened steel
- ▶ Delivered in wooden box without gauge blocks

A mm	B mm	⚖ kg	Nº
613	500	1,8	1048 701
813	700	2,1	1048 702
1213	1100	2,7	1048 703
Standfuß 99x79x57mm / Base 99x79x57mm		1,9	1048 711
Anschlag 113x30x15mm / Stop 113x30x15mm		0,2	1048 712

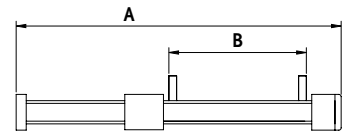
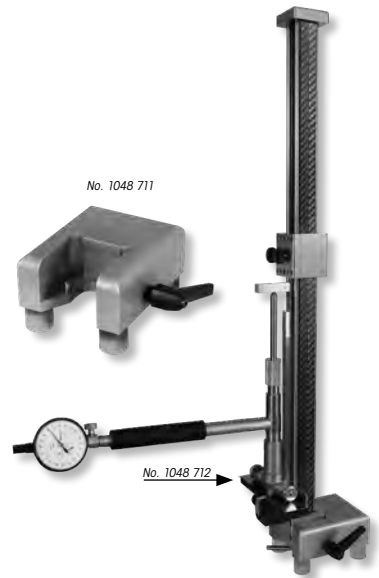

**Einstellgeräte  
für Innenfeinmessgeräte**

**Setting instruments  
for bore gauges**



- ▶ Werksnorm
- ▶ horizontal und vertikal einsetzbar
- ▶ Nennmaß wird durch Endmaße eingestellt
- ▶ Einstellbacken aus Hartmetall
- ▶ schwerer Standfuß
- ▶ Lieferung im Holzetui, ohne Endmaße

- ▶ Works standard
- ▶ Horizontal and vertical application
- ▶ Nominal size adjusted with gauge blocks
- ▶ Tungsten carbide setting jaws
- ▶ Heavy base
- ▶ Delivered in wooden box without gauge blocks

! Andere Einstellbacken für Fremdfabrikate auf Anfrage.

! Other setting jaws for other brands on request.

⌀ mm	⚖ kg	Nº
4,5 - 160	5,1	1048 501
4,5 - 290	5,3	1048 502
35 - 290	5,9	1048 503
160 - 510	12,1	1048 504
160 - 800	16,0	1048 505



**Einstellgerät für Vergleichsmeßgeräte,  
Innengewinde- und Außengewinde**

**Setting instrument for comparative meas.  
instruments, internal- and external threads**



- ▶ **Auf Anfrage!**  
Bitte gewünschtes Gewinde, Größe und Steigung angeben.

- ▶ **On request!**  
Please indicate required thread type, size and pitch.

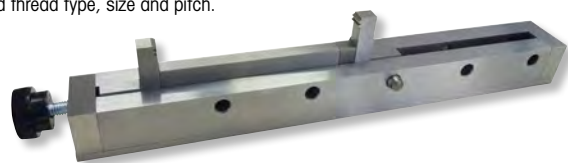

## Messkugelsätze

## Measuring ball sets



- ▶ Werksnorm
- ▶ Nennmaßtoleranz  $\pm 1\mu$
- ▶ Rundheit  $0,65\mu$
- ▶ Lieferung im Etui

- ▶ Works standard
- ▶ Nominal size tolerance  $\pm 1\mu$
- ▶ Roundness  $0.65\mu$
- ▶ Delivered in a case

1060 ... :

Chromstahl

1060 ... :

Chrome steel

1061 ... :

rostfreier Stahl, gehärtet

1061 ... :

Stainless steel, hardened

1062 ... :

Hartmetall

1062 ... :

Tungsten carbide



No. 1061 101

**!** Messkugelsätze  $\varnothing 0,4 - 100\text{mm}$  aus Chromstahl, Keramik oder Rubin sowie andere Satzzusammenstellungen auf Anfrage.

**!** Measuring sets  $\varnothing 0.4 - 100\text{mm}$  made of chromium steel, ceramic or ruby and other set compositions on request.

Stück Pieces	$\varnothing$ mm	$\sqrt{r}$ mm	$\bar{m}$ kg	Nº	Nº	Nº
Satz mit 1 Kugel je Nenn $\varnothing$ / Set with 1 ball per nominal $\varnothing$						
25	1 - 25	1	1,3	1060 151	1061 101	1062 101
49	1 - 25	0,5	2,0	1060 152	1061 102	1062 102
Satz mit 3 Kugeln je Nenn $\varnothing$ / Set with 3 balls per nominal $\varnothing$						
75	1 - 25	1	3,5	1060 251	1061 201	1062 201
147	1 - 25	0,5	5,3	1060 252	1061 202	1062 202

## Messkugeln einzeln

## Measuring balls singels



- ▶ Werksnorm
- ▶ Nennmaßtoleranz  $\pm 1\mu$
- ▶  $\varnothing 0,4 - 100\text{mm}$
- ▶ Lieferung einzeln verpackt

- ▶ Works standard
- ▶ Nominal size tolerance  $\pm 1\mu$
- ▶  $\varnothing 0.4 - 100\text{mm}$
- ▶ Delivered in individual packages

### Werkstoff:

- ▶ Chromstahl
- ▶ Rostfreier Stahl
- ▶ Hartmetall
- ▶ Keramik
- ▶ Rubin

### Material:

- ▶ Chrome steel
- ▶ Stainless steel
- ▶ Tungsten carbide
- ▶ Ceramic
- ▶ Ruby

**!** Preise auf Anfrage

**!** Prices on request



Chromstahl Messkugeln  
Chrome steel balls



Keramik Messkugeln  
Ceramic balls

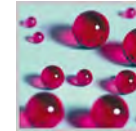

Rubin Messkugeln  
Ruby balls

## Kugellehren aus Hartmetall

## Ball gauges, tungsten carbide



Hartmetall  
Tungsten carbide

- ▶ Werksnorm
- ▶ Nennmaßtoleranz  $\pm 1\mu$
- ▶  $\varnothing 0,4 - 100\text{mm}$
- ▶ Sechskant Aluminiumgriff mit Spannzangen und Nennmaßbeschriftung
- ▶ Lieferung einzeln verpackt

- ▶ Works standard
- ▶ Nominal size tolerance  $\pm 1\mu$
- ▶  $\varnothing 0.4 - 100\text{mm}$
- ▶ Hexagon aluminium handle with collets and marked nominal size
- ▶ Delivered in individual packages

**!** Preise auf Anfrage

**!** Prices on request



Kugellehren einseitig  
Ball gauges single ended

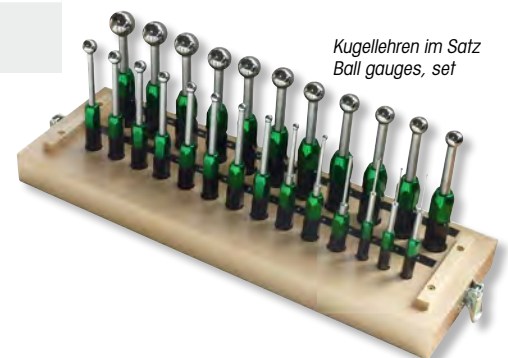

Kugellehren im Satz  
Ball gauges, set



Kugellehren zweiseitig (Gut / Ausschub)  
Ball gauges double ended (Go / No Go)

# 2

## Prüfstifte, Messdorne

Pin gauges

## Gewindemessdrähte

Thread measuring wires

## Lehrdorne, Kegellehren, Prüfdorne

Plug gauges, Taper gauges, Test plug gauges

## Werkzeu gvoreinstellgerä te

Tool pre-setting instruments

## SK / HSK Messgerä te

SK / HSK measuring devices

## Einstellringe, Rachenlehren

Setting ring gauges, Snap gauges



 **NEW**

Pneumatische Kegelmessgerä te  
Pneumatic taper gauges

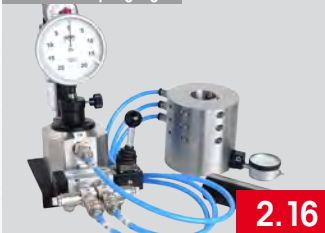

2.16

Einstellringe aus Keramik  
Setting ring gauges, ceramic



2.18

Universal Rachenlehren SNAPMATIC  
Universal snap gauges SNAPMATIC



2.22

Digital-Passameter  
Digital Passameter



2.23

## Rundpassungslehren

### Material- und Schichteigenschaften von Lehren im Vergleich:

Die Angabe der Verschleißfestigkeit erfolgt im Vergleich zu Lehrenstahl und kann nur als ca. ± Richtwert angenommen werden, da diese Werte von Umgebungsbedingungen und Werkstückmaterialien beeinflusst werden können.

Eigenschaften Properties	Lehrenstahl Steel	Hartchrom Hard chrome	TIN (gold) TiN (gold)	TICN (violet) TiCN (violet)	Hartmetall Tungsten carbide
Härte Hardness	62 HRc ± 2	900 HV	2500 HV	3000 HV	1800 HV
Verschleißfestigkeit Wear resistance	1x	5x	10x	15x	40x
Korrosionsbeständigkeit Corrosion resistance	weniger gut Satisfactory	gut Good	sehr gut Very good	sehr gut Very good	sehr gut Very good

### Toleranzen:

Es werden Arbeitslehren (mit Abnutzungsaufmaß auf der Gutseite) geliefert, wenn nicht abweichend bestellt.

Die Abmaße für Rundpassungslehren werden in der Regel nach dem ISO-Toleranzfeld für Bohrungen und Wellen angegeben.

Toleranzangaben für Grenzlehndorne werden in Großbuchstaben (H7, J8 usw.) angegeben.

Toleranzangaben für Rachenlehren werden in Kleinbuchstaben (f7, k6 usw.) angegeben.

Bitte geben Sie bei Ihrer Bestellung die entsprechende ISO-Passung oder eine zahlenmäßige Toleranz an.

### Zwischenmaßregelung:

Für Zwischenmaße, zahlenmäßige Toleranzangaben, Qualität 6 und feiner sowie Abnahmelehren (ohne Abnutzungsaufmaß) werden Zuschläge berechnet.

### Sonderausführungen auf Anfrage:

- TIN und TICN beschichtete oder hartverchromte Lehren
- Hartmetallbestückte Messflächen
- Kugellehren
- Lehren nach Kundenzeichnung

### Kalibrierung:

Für alle Lehren können Werkskalibrierscheine erstellt werden. Eine DAkkS-Kalibrierung durch ein akkreditiertes Labors ist für viele Lehrentypen ebenfalls möglich. Bitte beachten Sie hierzu unsere Nettopreisliste für die Erstellung von Prüfberichten.

Weiter Informationen erhalten Sie unter:

[www.ultra-germany.com](http://www.ultra-germany.com) > Produkte > Service > Prüfmittelüberwachung

### Kundenschnellservice:

Mit diesem Service ermöglichen wir für Lehren extrem kurze Lieferzeiten gegenüber der üblichen Standard-Lieferzeit. Die Fertigung erfolgt in der Regel in Überstunden. Für diese besondere Leistung werden entsprechende Zuschläge zu den Grundpreisen berechnet.

Die Möglichkeit für einen Schnellservice muss im Einzelfall für jede gewünschte Lehre geprüft werden.

Bitte vermerken Sie hierzu in Ihrer Anfrage „Lieferung im Kundenschnellservice“ und Ihren Wunschtermin.

### Grenzlehndorne mit Sondermessflächen:

Wir liefern Grenzlehndorne mit besonderen Messflächenformen, auch nach Ihren Zeichnungen.

Zur Angebotserstellung bitten wir um die Zusendung Ihrer Anfrage mit Prinzipskizze.

### Beispiele für mögliche Sonderformen:

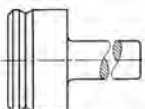

Messzapfen mit Pilotieransatz DIN 6338  
Plug gauge with pilot easy entry DIN 6338

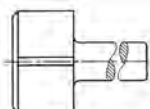

Messzapfen mit Lufrute  
Plug gauge with air groove

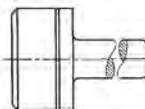

Messzapfen mit Tiefenmarkierung  
Plug gauge with depth mark

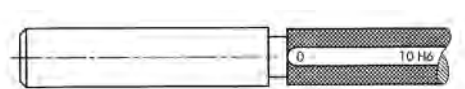

Messzapfen in Sonderlänge  
Plug gauge in special length

## Cylindrical limit gauges

### Material and coat properties of gauges in comparison:

The specification of wear resistance is carried out in relation to tool steel and can only be considered as a rough recommended value ±, since these values can be significantly influenced by environmental conditions and workpiece materials.

### Tolerances:

We supply working gauges (with wear allowance on GO-side) if not ordered different.

The limit of tolerances for cylindrical limit gauges is stated generally according to the ISO tolerance class for shafts and holes.

Tolerance specifications for limit plug gauges are given in capitals (H7, J8, etc.).

Tolerance specifications for snap gauges are given in lower type (f7, k6, etc.). Please specify the corresponding ISO tolerance or a numerical tolerance in your order.

### Provision for intermediate sizes:

Intermediate dimensions, numerical tolerances, quality 6 and finer, as well as check gauges (without wear allowance) have extra charge.

### Special models on request:

- TIN and TICN-coated or hard chrome-plated gauges
- Ball gauges
- Tungsten carbide-tipped measuring faces
- Gauges according to customer's drawing

### Calibration:

Works calibration certificates can be issued for all gauges. A DAkkS calibration from an accredited laboratory is likewise provided for many gauge types. Please note our net price list for the preparation of calibration certificates.

Further information at:

[www.ultra-germany.com](http://www.ultra-germany.com) > Products > Service > Calibration

### Customer express service:

We offer extremely short delivery times with this service compared to the usual standard delivery time. In general, the production is manufactured in overtime. An appropriate extra fee is added to the basic price for this special service.

The possibility for an express service must be checked in individual cases especially for each desired gauge.

Please mark your enquiry with "To be delivered in Customer Express Service" and mention your desired date.

### Limit plug gauges with special measuring faces:

We supply limit plug gauges with special measuring faces and also according to your drawings.

For the preparation of a quotation, we request you to send your inquiry with a schematic drawing.

### Example for possible special designs:

## Lehren aus Hartmetall & Keramik

## Tungsten carbide & ceramic gauges

### ► Kugellehren aus Hartmetall

Wir liefern alle Arten von Kugellehren, einseitig oder doppelseitig (Gut / Ausschuss), einzeln oder in Sätzen (Satzzusammenstellung nach Ihrer Vorgabe) in beliebigen Durchmessern von  $\varnothing$  0,4-100mm um 0,001mm steigend. Sonderanfertigungen nach Ihren Vorgaben oder Zeichnungen sind ebenfalls möglich. Wenn gewünscht mit Werkskalibrierschein gegen Berechnung.

### ► Ball gauges made of tungsten carbide

We supply any type of ball gauges, single ended or double ended (GO / NOGO), individual or in sets (set composition according to the customer's specifications), with any diameter from  $\varnothing$  0,4 to 100mm in steps of 0,001mm. Special executions according to your specifications or drawings are also realisable. On request works calibration certificates at extra charge.



### ► Messkugeln einzeln oder als Satz

Wir liefern alle Arten von Messkugeln, einzeln oder in Sätzen (Satzzusammenstellung nach Ihrer Vorgabe) aus Chromstahl, rostfreiem Stahl, Hartmetall oder Keramik in beliebigen Durchmessern von  $\varnothing$  0,4-100mm um 0,001mm steigend. Sondermesskugeln nach Ihren Vorgaben (z.B. mit Schaft oder Innengewinde) sind ebenfalls möglich.

### ► Measuring balls, singles, and measuring ball sets

We supply any type of measuring balls, single or in sets (set composition according to the customer's specifications) made of chrome steel, stainless steel, tungsten carbide or ceramics, with any diameter from  $\varnothing$  0,4 to 100mm in steps of 0,001mm. Special measuring balls according to your specifications (e.g. with shaft or internal thread) are also realisable. On request with works calibration certificates at extra charge.



### ► Prüfstifte aus Hartmetall und Keramik

Wir liefern jede Art von Prüfstiften aus Hartmetall (ab  $\varnothing$  0,80mm) und Keramik (ab  $\varnothing$  0,50mm) in verschiedenen Längen und verschiedenen Genauigkeiten. Sonderprüfstifte nach Ihren Vorgaben oder Zeichnungen sind ebenfalls möglich.

### ► Pin gauges of tungsten carbide and ceramics

We supply any type of pin gauges of tungsten carbide (from  $\varnothing$  0,80mm) and ceramics (from  $\varnothing$  0,50mm) in different lengths and different accuracy grades. Special pin gauges according to your specifications or drawings are also realisable.



### ► Grenzzehrdorne aus Hartmetall und Keramik

Wir liefern jede Art von Grenzzehrdornen aus Hartmetall (ab  $\varnothing$  1mm nach DIN 2245) und Keramik (ab  $\varnothing$  0,5mm nach Werksnorm). Sondergrenzzehrdorne nach Ihren Vorgaben oder Zeichnungen sind ebenfalls möglich.

### ► Limit plug gauges made of tungsten carbide and ceramics

We supply any type of limit plug gauges made of tungsten carbide (from  $\varnothing$  1mm acc. to DIN 2245) and ceramics (from  $\varnothing$  0,5mm acc. to works standards). Special limit plug gauges according to your specifications or drawings are also realisable.

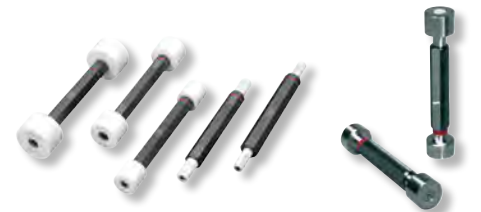

### ► Einstellringe aus Hartmetall und Keramik

Wir liefern jede Art von Einstellringen aus Hartmetall (ab  $\varnothing$  1mm nach DIN 2250-C) und Keramik (ab  $\varnothing$  2mm nach Werksnorm). Sondereinstellringe nach Ihren Vorgaben oder Zeichnungen sind ebenfalls möglich.

### ► Setting ring gauges of tungsten carbide and ceramics

We supply any type of setting ring gauges made of tungsten carbide (from  $\varnothing$  1mm acc. to DIN 2250-C) and ceramics (from  $\varnothing$  2mm acc. to works standards). Special setting ring gauges according to your specifications or drawings are also realisable.



### ► Gewindelehren aus Hartmetall und Keramik

Wir liefern Grenz-Gewindelehren und Gewindelehrringe aus Hartmetall (nach ISO 1502 (DIN 13)), sowie Grenz-Gewindelehren aus Keramik (ab M 1,4 bis M 12). Auch Sondergewindelehren nach Ihren Vorgaben oder Zeichnungen sind teilweise möglich.

### ► Thread gauges of tungsten carbide and ceramics

We supply limit thread plug gauges and thread ring gauges made of tungsten carbide (acc. to ISO 1502 (DIN 13)) as well as limit thread plug gauges made of ceramics (from M 1,4 to M 12). Special thread gauges according to your specifications or drawings are also realisable.



### ► Verzahnungslehren

Wir liefern alle Arten von Verzahnungslehren aus gehärtetem Lehenstahl oder ASP 30 (65-67 HRC).

### ► Serration spline gauges

We supply any type of serration spline gauges made of hardened tool steel or ASP 30 (65-67 HRC).

Lehren für Evolventenverzahnung und Meisterräder nach DIN Normen (Bsp. DIN 5462 / 5463 / 5464 / 5471 / 5472) oder nach Lehren- oder Werkstückzeichnungen.

Gauges for involute spline and master gears according DIN (DIN 5462 / 5463 / 5464 / 5471 / 5472) and special design spline gauges according to customers drawings.



## Prüfstiftsätze aus Spezialstahl, gehärtet

## Pin gauge sets, hardened special steel



- ▶ DIN 2269
- ▶ ab Ø 1,5mm mit Nennmaß beschriftet
- ▶ Bohrungen im Etui mit Nennmaß beschriftet
- ▶ Lieferung im Holzetui

- ▶ DIN 2269
- ▶ Nominal size marked from Ø 1.5mm
- ▶ Bore nominal sizes marked on the box
- ▶ Delivered in wooden box

**1066 1.. :**  
Toleranz ± 0,001mm

**1066 1.. :**  
Tolerance ± 0.001mm

**1067 2.. :**  
Toleranz ± 0,002mm

**1067 2.. :**  
Tolerance ± 0.002mm

**!** Prüfstiftsätze aus Hartmetall oder Keramik sowie andere Satzzusammenstellungen und Prüfstiftsätze mit Griff auf Anfrage.

**!** Pin gauge sets made of tungsten carbide or ceramic, other set compositions and pin gauges with handle on request.

Ø mm	mm	Stück Pieces	kg	±0,001mm №	±0,002mm №
0,1 – 0,3	0,01	21	1,83	<b>1066 101</b>	<b>1067 201</b>
0,3 – 0,5	0,01	21	1,83	<b>1066 102</b>	<b>1067 202</b>
0,5 – 1,0	0,01	51	1,83	<b>1066 103</b>	<b>1067 203</b>
0,1 – 1,0	0,05	19	1,9	<b>1066 104</b>	<b>1067 204</b>
1,0 – 5,0	0,1	41	1,97	<b>1066 105x</b>	<b>1067 205x</b>
1,0 – 10,0	0,1	91	4,5	<b>1066 105</b>	<b>1067 205</b>
1,01 – 2,0	0,01	100	1,9	<b>1066 115</b>	<b>1067 215</b>
2,01 – 3,0	0,01	100	2,1	<b>1066 116</b>	<b>1067 216</b>
3,01 – 4,0	0,01	100	2,3	<b>1066 117</b>	<b>1067 217</b>
4,01 – 5,0	0,01	100	2,6	<b>1066 118</b>	<b>1067 218</b>
5,01 – 6,0	0,01	100	2,9	<b>1066 119</b>	<b>1067 219</b>
6,01 – 7,0	0,01	100	3,8	<b>1066 120</b>	<b>1067 220</b>
7,01 – 8,0	0,01	100	4,3	<b>1066 121</b>	<b>1067 221</b>
8,01 – 9,0	0,01	100	4,9	<b>1066 122</b>	<b>1067 222</b>
9,01 – 10,0	0,01	100	5,8	<b>1066 123</b>	<b>1067 223</b>

Zusätzlich zu jedem NennØ je 1 Stift mit +0,01mm und -0,01mm  
1 pin each with + 0.01mm and - 0.01mm in addition to every nominal Ø

Ø mm	mm	Stück Pieces	kg	±0,001mm №	±0,002mm №
1,00 – 10,0	0,1 +0,01 / -0,01	273	7,68	<b>1066 250</b>	<b>1067 250</b>



No. 1066 105

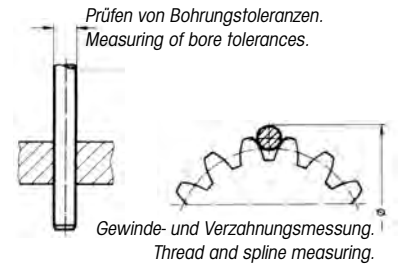

Prüfen von Bohrungstoleranzen.  
Measuring of bore tolerances.

Gewinde- und Verzahnungsmessung.  
Thread and spline measuring.

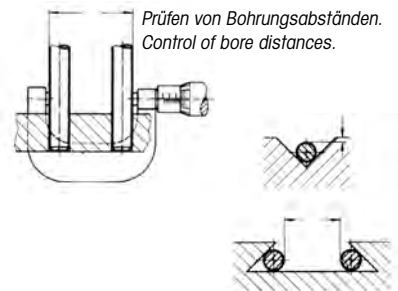

Prüfen von Bohrungsabständen.  
Control of bore distances.

Winkel- und Profilprüfung.  
Control of angles and profiles.

## Griffe für Prüfstifte, einzeln

## Handles for pin gauges, singles



- ▶ Beschriftet mit dem Prüfstift - Ø
- ▶ Lieferung einzeln verpackt, nur in Verbindung mit Prüfstiften

- ▶ Marked with pin gauge Ø
- ▶ Delivered in individual packages, only together with pin gauges

**!** Bei Bestellung Prüfstift - Ø angeben

**!** Specify pin gauge Ø in order

**1063 101 :**  
Kunststoffgriffe für Prüfstifte bis Ø 4mm  
(nur für Stahl Prüfstifte)

**1063 101 :**  
Plastic handles for pin gauges until Ø 4mm  
(only for steel pins)

**1063 201 :**  
Alusechskantgriffe für Prüfstifte bis Ø 10mm

**1063 201 :**  
Hexagonal aluminium handles for pin gauges until Ø 10mm



No. 1063 101

No. 1063 201

## Prüfstifthalter

## Pin gauge holder



- ▶ Druckguss mit Klemmschraube
- ▶ zur Aufnahme von 2 Prüfstiften
- ▶ z.B. als Grenzlehndorn verwendbar
- ▶ Lieferung einzeln verpackt ohne Prüfstifte

- ▶ Diecast with clamping screw
- ▶ Holding fixtures for 2 pin gauges
- ▶ Applicable, for example, as limit plug gauge
- ▶ Delivered in individual packages without pins

Ø mm	mm	kg	№	Ø mm	mm	kg	№
1 – 1,99	60	0,02	<b>1071 101</b>	7 – 9,50	84	0,045	<b>1071 104</b>
2 – 4,50	68	0,03	<b>1071 102</b>	9,51 – 12	92	0,08	<b>1071 105</b>
4,51 – 6,99	75	0,035	<b>1071 103</b>				

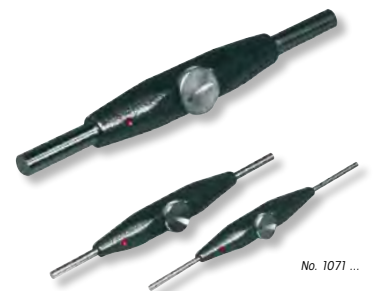

No. 1071 ...



**Prüfstifte einzeln, aus Spezialstahl gehärtet | Pin gauges singles, hardened special steel**

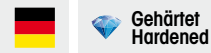

- ▶ DIN 2269
- ▶ ab Ø 1,5mm mit Nennmaß beschriftet
- ▶ Lieferung einzeln verpackt

- ▶ DIN 2269
- ▶ Nominal size marked from Ø 1.5mm
- ▶ Delivered in individual packages

<b>1064 ... :</b> Toleranz ± 0,0005mm	<b>1064 ... :</b> Tolerance ± 0.0005mm
<b>1068 ... :</b> Toleranz ± 0,001mm	<b>1068 ... :</b> Tolerance ± 0.001mm
<b>1069 ... :</b> Toleranz ± 0,002mm	<b>1069 ... :</b> Tolerance ± 0.002mm



! Andere Längen, Prüfstifte aus rost- und säurebeständigem Stahl oder Keramik sowie Messstifte mit Griff und Öse, auf Anfrage.

! Other length, pin gauges made of stainless and acid resistant steel or ceramic as well as measuring pins with handle and eye on request.

Ø mm	mm	mm	±0,0005mm N <sup>o</sup>	mm	±0,001mm N <sup>o</sup>	mm	±0,002mm N <sup>o</sup>
0,1 - 0,14	0,01	30	1064 099	40	1068 099	40	-
0,15 - 0,29	0,01	30	1064 100	40	1068 100	40	-
0,30 - 0,49	0,01	30	1064 100x	40	1068 100x	40	1069 100x
0,5 - 0,99	0,01	30	1064 101	40	1068 101	40	1069 101
1,00 - 2,99	0,01	30	1064 201	70	1068 201	70	1069 201
3,00 - 5,99	0,01	35	1064 301	70	1068 301	70	1069 301
6,00 - 9,99	0,01	40	1064 401	70	1068 401	70	1069 401
10,00 - 11,99	0,01	-	-	70	1068 501	70	1069 501
12,00 - 13,99	0,01	-	-	70	1068 601	70	1069 601
14,00 - 15,99	0,01	-	-	70	1068 701	70	1069 701
16,00 - 18,99	0,01	-	-	70	1068 801	70	1069 801
19,00 - 20,00	0,01	-	-	70	1068 901	70	1069 901



Option Kunststoffgriffe bis Ø 4mm  
Option plastic handles until Ø 4mm



Option Aluminiumgriffe bis Ø 10mm  
Option aluminium handles until Ø 10mm

**Prüfstifte einzeln, aus Hartmetall | Pin gauges singles, tungsten carbide**



- ▶ Werksnorm
- ▶ ab Ø 3mm mit Nennmaß beschriftet
- ▶ Toleranz ± 0,001mm
- ▶ Lieferung einzeln verpackt

- ▶ Works standard
- ▶ Nominal size marked from Ø 3mm
- ▶ Tolerance ± 0.001mm
- ▶ Delivered in individual packages

! Andere Längen, Toleranzen oder größere Durchmesser auf Anfrage.

! Other length, tolerance or larger diameter on request.

Ø mm	mm	mm	N <sup>o</sup>	Ø mm	mm	mm	N <sup>o</sup>
0,80 - 0,99	0,01	30	1072 099	11,00 - 11,99	0,01	50	1074 116
1,00 - 1,49	0,01	40	1073 100	12,00 - 12,99	0,01	50	1074 117
1,50 - 1,99	0,01	40	1073 101	13,00 - 13,99	0,01	50	1074 118
2,00 - 2,49	0,01	40	1073 111	14,00 - 14,99	0,01	50	1074 119
2,50 - 2,99	0,01	40	1073 102	15,00 - 15,99	0,01	50	1074 120
3,00 - 3,49	0,01	40	1073 112	16,00 - 16,99	0,01	50	1074 121
3,50 - 3,99	0,01	40	1073 103	17,00 - 17,99	0,01	50	1074 122
4,00 - 4,49	0,01	40	1073 113	18,00 - 18,99	0,01	50	1074 123
4,50 - 4,99	0,01	40	1073 104	19,00 - 19,99	0,01	50	1074 124
5,00 - 5,49	0,01	40	1073 114	20,00 - 20,99	0,01	50	1074 125
5,50 - 5,99	0,01	40	1073 105	21,00 - 21,99	0,01	50	1074 126
6,00 - 6,99	0,01	40	1073 106	22,00 - 22,99	0,01	50	1074 127
7,00 - 7,99	0,01	40	1073 107	23,00 - 23,99	0,01	50	1074 128
8,00 - 8,99	0,01	40	1073 108	24,00 - 24,99	0,01	50	1074 129
9,00 - 9,99	0,01	40	1073 109	25,00	-	50	1074 130
10,00 - 10,99	0,01	50	1074 115	> 25mm	auf Anfrage / on request		



Option Aluminiumgriffe bis Ø 10mm  
Option aluminium handles until Ø 10mm

## Prüfstifte, aus Keramik

## Pin gauges, ceramic



TOP



Keramik  
Ceramic

- ▶ Werksnorm
- ▶ extrem hart und korrosionsbeständig, absolut verschleißfest
- ▶ Lieferung einzeln verpackt

- ▶ Works standard
- ▶ Extremely hard, anti-corrosive and absolutely wear-resistant
- ▶ Delivered in individual packages

**I** Ø 0,5 – 30mm, Ausführungen mit und ohne Griff, einseitig und doppelseitig (Grenzlehndorn) – auf Anfrage.  
Zur Angebotserstellung benötigen wir den Nenndurchmesser, die Toleranz sowie die Messflächenlänge

**I** Ø 0,5 – 30mm, models with and without handle, single ended or double ended (Limit plug gauge) – on request.  
For the preparation of a quotation please specify the required nominal diameter, tolerance and length.



Auf Anfrage / on request

## Gewindemessdrähte für Außengewindemessung

## Thread measuring wires for external thread measurements



Gehärtet  
Hardened

- ▶ 3-Drahtmethode
- ▶ Messrollen gehärtet
- ▶ Ø Tol. ±0,5µ
- ▶ Lieferung paarweise verpackt

- ▶ 3-wire method
- ▶ Hardened rollers
- ▶ Ø tolerance ±0.5µ
- ▶ Delivered in a package (pair)

Bei Trapezgewinde bitte die Steigung angeben.

For trapezoidal please specify pitch.

### 2046 1.. :

1 Paar Messdrähte im Halter für Mikrometer, Klemmung auf der Mikrometerspindel durch Federring. Unbedingt Messschrauben-Spindeldurchmesser (Ø6,0 / 6,35 / 6,5 / 8,0mm) angeben.

### 2046 1.. :

1 pair of wires in holder for micrometers, spring ring clamping on the micrometer spindle. Specify micrometer spindle diameter (Ø6.0 / 6.35 / 6.5 / 8.0mm).

### 2046 2.. :

3 Stück Messdrähte mit Öse für Messmaschine

### 2046 2.. :

3 wire pieces with eyes for measuring device

**I** Andere Durchmesser sowie Messrollen zur Verzahnungsmessung auf Anfrage.

**I** Other diameters and rollers for gear measurements on request.

Messdraht Wire d Ø mm	Metrisch Metric mm	Withworth Gang / Zoll Thread / inch	UN, UNC, UNF Gang / Zoll Thread / inch	Trapez Trapezoidal	Nº	Nº
0,17	0,25 / 0,3	-	-	-	2046 101	2046 201
0,195	-	-	80	-	2046 102	2046 202
0,22	0,35	-	72	-	2046 103	2046 203
0,25	0,4	60	64	-	2046 104	2046 204
0,29	0,45 / 0,5	-	56	-	2046 105	2046 205
0,335	0,6	48 / 40	48 / 44	-	2046 106	2046 206
0,39	-	40	44 / 36	-	2046 107	2046 207
0,455	0,7 / 0,75 / 0,8	-	32	-	2046 108	2046 208
0,53	0,9	32 / 28	28	-	2046 109	2046 209
0,62	1	26 / 24	24	-	2046 110	2046 210
0,725	1,25	22 / 20 / 19	20	-	2046 111	2046 211
0,895	1,5	18 / 16	18 / 16	1,5	2046 112	2046 212
1,1	1,75	14	14 / 13	2	2046 113	2046 213
1,35	2	12 / 11	12 / 11	-	2046 114	2046 214
1,65	2,5	10 / 9	10 / 9	3	2046 115	2046 215
2,05	3 / 3,5	8 / 7	8 / 7	4	2046 116	2046 216
2,55	4 / 4,5	6	6	5	2046 117	2046 217
3,2	5 / 5,5	5 / 4 1/2	5 / 4 1/2	6	2046 118	2046 218
4,00	6	4 / 3 1/2	4	7 / 8	2046 119	2046 219
5,05	8	3 1/4 / 3 2 7/8 / 2 3/4	-	9 / 10	2046 120	2046 220
6,35	-	2 5/8 / 2 1/2	-	12	2046 121	2046 221
Satz im Holzetui (21 Paare) / Set in wooden box (21 pairs)					2046 130	2046 230

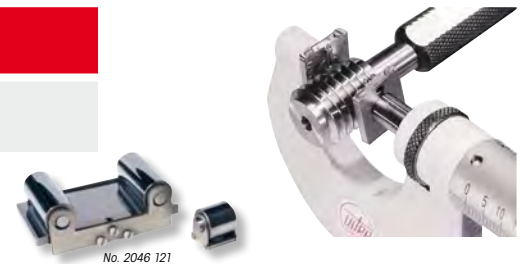

No. 2046 121

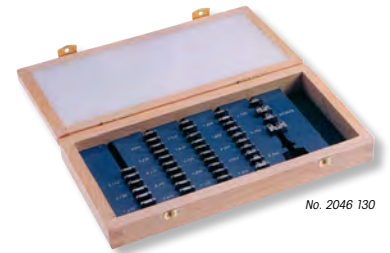

No. 2046 130



No. 2046 217

DØ = Außendurchmesser  
Outer diameter  
FØ = Flankendurchmesser  
Pitch diameter  
M = Prüfmaß  
Test dimension  
S = Gewindesteigung  
Thread pitch  
dØ = Messdrahtdurchmesser  
Wire diameter

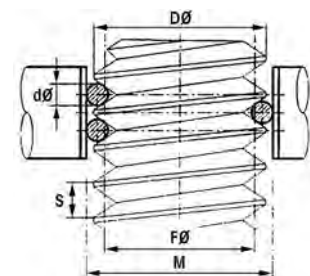

**Grenzlehrdorne, vollzylindrisch mit Alusechskantgriff**

**Limit plug gauges, cylindrical full form with hexagonal aluminium handle**

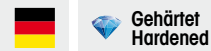

- ▶ Werksnorm
- ▶ Gut- und Ausschussseite
- ▶ Lehrenstahl gehärtet
- ▶ Messzapfen umsteckbar = doppelte Lebensdauer
- ▶ Gutseite mit Abnutzungsaufmass (Arbeitslehre)
- ▶ Passung H7
- ▶ Lieferung einzeln verpackt

- ▶ Works standard
- ▶ GO and NO-GO side
- ▶ Hardened tool steel
- ▶ Reversible pins = double life time
- ▶ GO side with wear allowance (workshop gauge)
- ▶ Tolerance H7
- ▶ Delivered in individual packages

**!** Für Zwischenmaße, zahlenmäßige Toleranzangaben, Qualität 6 und feiner sowie Abnahmelehren (ohne Abnutzungsaufmaß) werden Zuschläge berechnet.

**!** Intermediate dimensions, numerical tolerances, quality 6 and finer, as well as check gauges (without wear allowance) have extra charges.



No. 1070 ...

Ø mm	Nº
0,2 / 0,3	1070 101
0,4 / 0,5	1070 102
0,6 / 0,7 / 0,8 / 0,9	1070 103
1 / 1,2 / 1,4 / 1,5 / 1,8 / 2,0	1070 104

Ø mm	Nº
2,2 / 2,5 / 2,8 / 3 / 3,5 / 4	1070 105
4,5 / 5 / 5,5	1070 106
6 / 7	1070 107
8 / 9 / 10	1070 108

**Tolerator, Filetor, Converter**

**Tolerator, Filetor, Converter**



- ▶ Kunststoffgehäuse
- ▶ mehrsprachige Ausführung, International verwendbar
- ▶ Lieferung einzeln verpackt

- ▶ Plastic housing
- ▶ Multilingual version, can be used internationally
- ▶ Delivered in individual packages

**1164 101 :**  
Tolerator (ISO Toleranzschlüssel)  
Toleranzwerte nach ISO Empfehlung R 286-1962 bis Nennmaß 500mm

**1164 101 :**  
Tolerator (ISO tolerance key)  
Tolerance value according to ISO recommendation R 286-1962 up to nominal size 500 mm

**1164 102 :**  
Filetor (Gewindeanzeiger)  
Gewindebezeichnung mit allen dazugehörigen Maßen

**1164 102 :**  
Filetor (thread indicator)  
Thread marking with all appropriate dimensions

**1164 103 :**  
Converter (Maßumrechner)  
Umrechnung von mm in inch und umgekehrt

**1164 103 :**  
Converter (measurement converter)  
Conversion from mm to inch and vice versa

ℓ mm	kg	Nº	Nº	Nº
110x60x30	0,1	1164 101	1164 102	1164 103



No. 1064 101



No. 1064 102



No. 1064 103

**DIN Schieber**

**DIN rules**



- ▶ Aluminium, eloxiert
- ▶ Tabelle auf Vorder- und Rückseite
- ▶ Lieferung einzeln verpackt

- ▶ Anodised aluminium
- ▶ Tables on front and back sides
- ▶ Delivered in individual packages

**1165 101 :**  
DIN Gewindegewinde für metrisches ISO Regelgewinde, Whitworth-Gewinde, Whitworth-Rohrgewinde  
DIN ISO 228, Keilnutenabmessungen für Wellendurchmesser 10 bis 500mm

**1165 101 :**  
DIN thread rule for ISO standard metric thread, Whitworth thread, Whitworth pipe thread  
DIN ISO 228, keyway dimensions for shaft diameters 10 up to 500mm

**1165 102 :**  
DIN Passungsschieber für Einheitsbohrungen H6 bis H13, Einheitswellen h5 bis h12, Ø 1 bis 160mm

**1165 102 :**  
DIN fit rule for hole basis system of fits H6 up to H13, basic shaft system h5 up to h12, Ø 1 up to 160mm

**1165 103 :**  
DIN Gewindegewinde für metrisches ISO Feingewinde, Nenndurchmesser 1 bis 420mm

**1165 103 :**  
DIN thread rule for ISO standard metric fine screw thread, nominal diameter 1 up to 420mm

ℓ mm	kg	Nº	Nº
250x50x0,5	0,03	1165 101	1165 103
250x80x0,5	0,05	1165 102	-



No. 1165 101

No. 1165 101

## Grenzlehndorne, vollzylindrisch

## Limit plug gauges, cylindrical full form



**Gehärtet  
Hardened**

- ▶ DIN 2245
- ▶ Gut- und Ausschussseite
- ▶ Lehenstahl gehärtet
- ▶ Gutseite mit Abnutzungsaufmass (Arbeitslehre)
- ▶ Lieferung einzeln verpackt

- ▶ DIN 2245
- ▶ GO and NO-GO side
- ▶ Hardened tool steel
- ▶ GO side with wear allowance (workshop gauge)
- ▶ Delivered in individual packages

**1080 1.. :**  
Passung H7

**1080 1.. :**  
Tolerance H7

**1081 2.. :**  
ISO Toleranzfelder A-ZC, Qualität 8-13  
Bei Bestellung bitte Passung angeben

**1081 2.. :**  
ISO Tolerance A-ZC. Quality 8-13  
Please mention tolerance in your order

**!** Für Zwischenmaße, zahlenmäßige Toleranzangaben, Qualität 6 und feiner sowie Abnahmelehren (ohne Abnutzungsaufmaß) werden Zuschläge berechnet.

**!** Intermediate dimensions, numerical tolerances, quality 6 and finer, as well as check gauges (without wear allowance) have extra charges.

**!** TIN und TiCN beschichtete oder hartverchromte Grenzlehndorne und Messflächen in Sonderformen auf Anfrage.

**!** TIN- and TiCN-coated or hard chrome-plated limit plug gauges and measuring faces in special shapes on request.



No. 1080 ... TIN

No. 1080 ...

Ø mm	H7 N°	N°	Ø mm	H7 N°	N°	Ø mm	H7 N°	N°	Ø mm	H7 N°	N°
1,0	10801-1	10812-1	23,0	10801-23	10812-23	53,0	10801-53	10812-53	83,0	10801-83	10812-83
1,2	10801-1,2	10812-1,2	24,0	10801-24	10812-24	54,0	10801-54	10812-54	84,0	10801-84	10812-84
1,5	10801-1,5	10812-1,5	25,0	10801-25	10812-25	55,0	10801-55	10812-55	85,0	10801-85	10812-85
1,8	10801-1,8	10812-1,8	26,0	10801-26	10812-26	56,0	10801-56	10812-56	86,0	10801-86	10812-86
2,0	10801-2	10812-2	27,0	10801-27	10812-27	57,0	10801-57	10812-57	87,0	10801-87	10812-87
2,2	10801-2,2	10812-2,2	28,0	10801-28	10812-28	58,0	10801-58	10812-58	88,0	10801-88	10812-88
2,5	10801-2,5	10812-2,5	29,0	10801-29	10812-29	59,0	10801-59	10812-59	89,0	10801-89	10812-89
2,8	10801-2,8	10812-2,8	30,0	10801-30	10812-30	60,0	10801-60	10812-60	90,0	10801-90	10812-90
3,0	10801-3	10812-3	31,0	10801-31	10812-31	61,0	10801-61	10812-61	91,0	10801-91	10812-91
3,5	10801-3,5	10812-3,5	32,0	10801-32	10812-32	62,0	10801-62	10812-62	92,0	10801-92	10812-92
4,0	10801-4	10812-4	33,0	10801-33	10812-33	63,0	10801-63	10812-63	93,0	10801-93	10812-93
4,5	10801-4,5	10812-4,5	34,0	10801-34	10812-34	64,0	10801-64	10812-64	94,0	10801-94	10812-94
5,0	10801-5	10812-5	35,0	10801-35	10812-35	65,0	10801-65	10812-65	95,0	10801-95	10812-95
6,0	10801-6	10812-6	36,0	10801-36	10812-36	66,0	10801-66	10812-66	96,0	10801-96	10812-96
7,0	10801-7	10812-7	37,0	10801-37	10812-37	67,0	10801-67	10812-67	97,0	10801-97	10812-97
8,0	10801-8	10812-8	38,0	10801-38	10812-38	68,0	10801-68	10812-68	98,0	10801-98	10812-98
9,0	10801-9	10812-9	39,0	10801-39	10812-39	69,0	10801-69	10812-69	99,0	10801-99	10812-99
10,0	10801-10	10812-10	40,0	10801-40	10812-40	70,0	10801-70	10812-70	100,0	10801-100	10812-100
11,0	10801-11	10812-11	41,0	10801-41	10812-41	71,0	10801-71	10812-71	105,0	10801-105	10812-105
12,0	10801-12	10812-12	42,0	10801-42	10812-42	72,0	10801-72	10812-72	110,0	10801-110	10812-110
13,0	10801-13	10812-13	43,0	10801-43	10812-43	73,0	10801-73	10812-73	115,0	10801-115	10812-115
14,0	10801-14	10812-14	44,0	10801-44	10812-44	74,0	10801-74	10812-74	120,0	10801-120	10812-120
15,0	10801-15	10812-15	45,0	10801-45	10812-45	75,0	10801-75	10812-75	125,0	10801-125	10812-125
16,0	10801-16	10812-16	46,0	10801-46	10812-46	76,0	10801-76	10812-76	130,0	10801-130	10812-130
17,0	10801-17	10812-17	47,0	10801-47	10812-47	77,0	10801-77	10812-77	135,0	10801-135	10812-135
18,0	10801-18	10812-18	48,0	10801-48	10812-48	78,0	10801-78	10812-78	140,0	10801-140	10812-140
19,0	10801-19	10812-19	49,0	10801-49	10812-49	79,0	10801-79	10812-79	145,0	10801-145	10812-145
20,0	10801-20	10812-20	50,0	10801-50	10812-50	80,0	10801-80	10812-80	150,0	10801-150	10812-150
21,0	10801-21	10812-21	51,0	10801-51	10812-51	81,0	10801-81	10812-81	155,0	10801-155	10812-155
22,0	10801-22	10812-22	52,0	10801-52	10812-52	82,0	10801-82	10812-82	160,0	10801-160	10812-160

Beispiele für mögliche Sonderformen / Example for possible special designs:

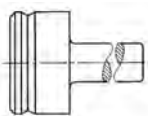

Messzapfen mit Pilotieransatz DIN 6338  
Plug gauge with pilot easy entry DIN 6338

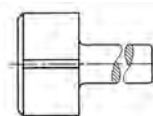

Messzapfen mit Luftnute  
Plug gauge with air groove

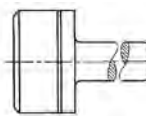

Messzapfen mit Tiefenmarkierung  
Plug gauge with depth mark



Messzapfen in Sonderlänge  
Plug gauge in special length

**Grenzlehrdorne aus Keramik**

**Limit plug gauges, ceramic**



**TOP**



**Keramik  
Ceramic**

- ▶ Werksnorm
- ▶ Gutseite mit Abnutzungsmaß (Arbeitslehre)
- ▶ extrem hart und korrosionsbeständig absolut verschleißfest
- ▶ Lieferung einzeln verpackt

- ▶ Works standard
- ▶ Go side with wear allowance (workshop gauge)
- ▶ Extremely hard, anti-corrosive and absolutely wear-resistant
- ▶ Delivered in individual packages



Auf Anfrage / on request

! Ø 0,5 – 25mm, einseitig und doppelseitig – auf Anfrage.  
Zur Angebotsstellung benötigen wir den Nenndurchmesser und die Toleranz.

! Ø 0.5 - 25mm, single ended or double ended – on request.  
For the preparation of a quotation please specify the required nominal diameter and the tolerance.

**Grenzlehrdorne aus Hartmetall**

**Limit plug gauges, tungsten carbide**



**TOP**



**Hartmetall  
Tungsten carbide**

- ▶ DIN 2245
- ▶ ISO Toleranzfelder A-ZC, Qualität 7-13
- ▶ Gutseite mit Abnutzungsmaß (Arbeitslehre)
- ▶ Lieferung einzeln verpackt

- ▶ DIN 2245
- ▶ ISO tolerance A-ZC, quality 7-13
- ▶ GO side with wear allowance (workshop gauge)
- ▶ Delivered in individual packages



No. 1087 1..

**1087 1.. :**  
Gutseite Hartmetall,  
Ausschussteile Lehrenstahl gehärtet

**1087 1.. :**  
GO side of tungsten carbide,  
NO-GO side of hardened steel

**1088 1.. :**  
Gutseite und Ausschussteile Hartmetall

**1088 1.. :**  
GO and NO-GO sides of tungsten carbide

! Bei Bestellung bitte Passung angeben.  
Für Zwischenmaße, zahlenmäßige Toleranzangaben, Qualität 6 und feiner sowie Abnahmelehren (ohne Abnutzungsmaß) werden Zuschläge berechnet.

! Please mention tolerance in your order.  
Intermediate dimensions, numerical tolerances, quality 6 and finer, as well as check gauges (without wear allowance) have extra charges.

! Nennmaße über Ø 50mm sowie Messflächen in Sonderformen auf Anfrage.

! Nominal sizes above Ø 50mm and measuring faces in special shapes on request.

Ø mm	Nº	Nº	Ø mm	Nº	Nº	Ø mm	Nº	Nº	Ø mm	Nº	Nº
1,0	1087 101	1088 101	13,0	1087 113	1088 113	25,0	1087 125	1088 125	39,0	1087 139	1088 139
2,0	1087 102	1088 102	14,0	1087 114	1088 114	26,0	1087 126	1088 126	40,0	1087 140	1088 140
3,0	1087 103	1088 103	15,0	1087 115	1088 115	27,0	1087 127	1088 127	41,0	1087 141	1088 141
4,0	1087 104	1088 104	16,0	1087 116	1088 116	28,0	1087 128	1088 128	42,0	1087 142	1088 142
5,0	1087 105	1088 105	17,0	1087 117	1088 117	30,0	1087 130	1088 130	43,0	1087 143	1088 143
6,0	1087 106	1088 106	18,0	1087 118	1088 118	32,0	1087 132	1088 132	44,0	1087 144	1088 144
7,0	1087 107	1088 107	19,0	1087 119	1088 119	33,0	1087 133	1088 133	45,0	1087 145	1088 145
8,0	1087 108	1088 108	20,0	1087 120	1088 120	34,0	1087 134	1088 134	46,0	1087 146	1088 146
9,0	1087 109	1088 109	21,0	1087 121	1088 121	35,0	1087 135	1088 135	47,0	1087 147	1088 147
10,0	1087 110	1088 110	22,0	1087 122	1088 122	36,0	1087 136	1088 136	48,0	1087 148	1088 148
11,0	1087 111	1088 111	23,0	1087 123	1088 123	37,0	1087 137	1088 137	49,0	1087 149	1088 149
12,0	1087 112	1088 112	24,0	1087 124	1088 124	38,0	1087 138	1088 138	50,0	1087 150	1088 150
									>50,0	auf Anfrage / on request	

**Schutzhülsen zur Aufbewahrung von Gewinde- und Rundpassungslehrdornen**

**Protection box for storage of thread- and cylindrical plug gauges**



- ▶ aus Polypropylen (transparent)
- ▶ stufenlose Längenverstellung durch Rastermechanik
- ▶ feuchtigkeits- und ölresistent
- ▶ Vierkantende sichert gegen Wegrollen
- ▶ wiederverschließbar und mehrfach verwendbar

- ▶ Polypropylene (transparent)
- ▶ Telescopic length extension through ratchet mechanism
- ▶ Humidity and oil resistant
- ▶ Square end prevents rolling
- ▶ Re-usable



für / for Ø mm	Innen-Ø / Internal-Ø mm	l x b x h mm	Nº
≤ 3	7	0,50 – 0,90	TP 7 050
> 3 – 6	9	0,65 – 1,10	TP 9 065
> 6 – 10	12	0,80 – 1,20	TP 12 080
> 10 – 14	16	0,80 – 1,20	TP 16 080
> 14 – 16	18	0,80 – 1,20	TP 18 080
> 16 – 20	20	0,80 – 1,20	TP 20 080
> 20 – 26	26	1,20 – 2,00	TP 26 120
> 26 – 30	30	1,20 – 2,00	TP 30 120

## Grenzlochlehren, flach mit zylindrischen Messflächen

## Limit plug gauges, flat with cylindrical measuring surfaces

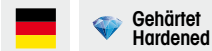

- ▶ DIN 2246 / DIN 2247
- ▶ Messflächen gehärtet
- ▶ ISO Toleranzfelder A-ZC, Qualität 7-13
- ▶ Ø-Stufung 1mm
- ▶ Gutseite mit Abnutzungsaufmass (Arbeitslehre)
- ▶ Lieferung einzeln, No. 1085 1.. paarweise verpackt

**1082 3.. :**  
im Gesenk geschmiedet,  
Gut- und Ausschussseite in einer Lehre

**1085 1.. :**  
Messflächen aus Lehrenstahl,  
Gut- und Ausschussseite getrennt (Paar)

- !** Bei Bestellung bitte Passung angeben.  
Für Zwischenmaße, zahlenmäßige Toleranzangaben, Qualität 6  
und feiner sowie Abnahmelehren (ohne Abnutzungsaufmaß)  
werden Zuschläge berechnet.

- !** Größere Nennmaße sowie hartverchromte Ausführung  
auf Anfrage.

Ø mm	Nº	Ø mm	Nº	Ø mm	Nº	Ø mm	Nº
4 – 10	1082 320	56 – 62	1082 354	101 – 110	1085 101	221 – 240	1085 109
11 – 15	1082 323	63 – 70	1082 358	111 – 120	1085 102	241 – 260	1085 110
16 – 24	1082 332	71 – 80	1082 362	121 – 135	1085 103	261 – 280	1085 111
25 – 29	1082 336	81 – 88	1082 370	136 – 150	1085 104	281 – 300	1085 112
30 – 35	1082 340	89 – 100	1082 372	151 – 165	1085 105	301 – 320	1085 113
36 – 40	1082 344			166 – 180	1085 106	321 – 350	1085 114
41 – 48	1082 347			181 – 200	1085 107		auf Anfrage on request
49 – 55	1082 351			201 – 220	1085 108	>350	

- ▶ DIN 2246 / DIN 2247
- ▶ Hardened measuring faces
- ▶ ISO tolerance A-ZC, quality 7-13
- ▶ Ø-step 1mm
- ▶ GO side with wear allowance (workshop gauge)
- ▶ Delivered in individual packages, No. 1085 1... in pairs

**1082 3.. :**  
Drop-forged,  
GO and NO-GO sides on one gauge

**1085 1.. :**  
Steel measuring surfaces,  
separate GO and NO-GO sides (pair)

- !** Please mention tolerance in your order.  
Intermediate dimensions, numerical tolerances, quality 6  
and finer, as well as check gauges (without wear allowance)  
have extra charges.

- !** Larger nominal sizes and hard chrome finishes  
on request.



No. 1082 ...



No. 1085 ...

## Kegellehren für Morsekegel

## Taper gauges for morse taper



- ▶ Lehrenstahl gehärtet
- ▶ Lieferung einzeln verpackt

- ▶ Hardened tool steel
- ▶ Delivered in individual packages

**1100 1.. :**  
DIN 229 Dorn

**1100 1.. :**  
DIN 229 Plug

**1101 2.. :**  
DIN 229 Hülse kurz

**1101 2.. :**  
DIN 229 Short sleeve

**1110 1.. :**  
DIN 230 Dorn mit Lappen

**1110 1.. :**  
DIN 230 Plug with tang

**1111 2.. :**  
DIN 230 Hülse mit einseitigem Lappen

**1111 2.. :**  
DIN 230 Sleeve with one-side tang

Größe Size	Nº	Nº	Nº	Nº
MK 0	1100 101	1101 201	1110 101	1111 201
MK 1	1100 102	1101 202	1110 102	1111 202
MK 2	1100 103	1101 203	1110 103	1111 203
MK 3	1100 104	1101 204	1110 104	1111 204
MK 4	1100 105	1101 205	1110 105	1111 205
MK 5	1100 106	1101 206	1110 106	1111 206
MK 6	1100 107	1101 207	1110 107	1111 207

No. 1101 204

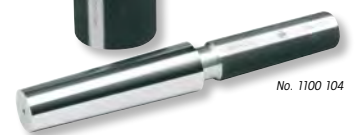

No. 1100 104



No. 1111 204

No. 1110 104

## Kegellehren für Steilkegel

## Taper gauges for steep taper



- ▶ Lehrenstahl gehärtet
- ▶ Lieferung einzeln verpackt

- ▶ Hardened tool steel
- ▶ Delivered in individual packages

1121 1.. :  
DIN 2079 Dorn

1121 1.. :  
DIN 2079 Plug

1122 2.. :  
DIN 2080 / DIN 69871 Hülse

1122 2.. :  
DIN 2080 / DIN 69871 Sleeve

Größe Size	Nº	Nº
SK 30	1121 102	1122 202
SK 40	1121 103	1122 203
SK 45	1121 104	1122 204
SK 50	1121 105	1122 205
SK 60	1121 106	1122 206



## Kegellehren für Spindelkopf und Futterflansch

## Taper gauges for spindle head and chuck flange



- ▶ Lehrenstahl gehärtet
- ▶ Lieferung einzeln verpackt

- ▶ Hardened tool steel
- ▶ Delivered in individual packages

1126 1.. :  
DIN 55028 / DIN 55029 Dorn

1126 1.. :  
DIN 55028 / DIN 55029 Plug

1126 2.. :  
DIN 55026 / DIN 55027 Hülse

1126 2.. :  
DIN 55026 / DIN 55027 Sleeve

Größe Size	Nº	Nº
3	1126 101	1126 201
4	1126 102	1126 202
5	1126 103	1126 203
6	1126 104	1126 204
8	1126 105	1126 205
11	1126 106	1126 206



### Kegellehren Sonderanfertigung

Kegellehren können auch in anderen Ausführungen, sowie nach Kundenzeichnung gefertigt werden. Hartverchromte Ausführungen sowie Hartmetall-Kegellehren auf Anfrage!

### Taper gauges in special design

Taper gauges can also be manufactured in other designs and according to customer drawings. Hard chrome-plated and tungsten carbide taper gauges are available on request!

## Rundlaufprüfdorne für Morsekegel

## Concentricity test plug gauge for morse taper



- ▶ DIN 229
- ▶ Kegel ohne Anzugsgewinde, mit Abdrückmutter
- ▶ Lehrenstahl gehärtet
- ▶ Rundlaufgenauigkeit und Zylindrizität 0,003mm
- ▶ Lieferung einzeln verpackt, ohne Etui

- ▶ DIN 229
- ▶ Taper without draw-in screw thread, with removing nut
- ▶ Hardened tool steel
- ▶ Concentricity and cylindricity 0.003mm
- ▶ Delivered in individual packages, without case

1125 2.. :  
Rundlaufprüfdorne

1125 2.. :  
Concentricity test plug gauge

1125 25. :  
Holzetui

1125 25. :  
Wooden box

! Kegel ohne Abdrückmutter oder mit Anzugsgewinde auf Anfrage.

! Taper without removing nut or with draw-in screw thread on request.

Größe Size	Ø mm	l mm	W kg	Nº	Nº
MK 2	20	200	1,0	1125 203	1125 253
MK 3	25	250	1,5	1125 204	1125 254
MK 4	32	300	2,5	1125 205	1125 255
MK 5	40	300	4,5	1125 206	1125 256
MK 6	50	300	9,5	1125 207	1125 257



## Rundlaufprüfdorne für Steilkegelspindeln

## Concentricity test plug gauge for steep taper spindles



- ▶ DIN 2080
- ▶ Lehenstahl gehärtet
- ▶ Rundlaufgenauigkeit und Zylindrizität 0,003 mm
- ▶ Lieferung im Holzetui inkl. Werkskalibrierschein

- ▶ DIN 2080
- ▶ Hardened tool steel
- ▶ Concentricity and cylindricity 0.003 mm
- ▶ Delivered in wooden box with works calibration certificate

Größe Size	Ø mm	l mm	kg	Nº
SK 30	32	200	1,2	1125 401
SK 40	40	300	1,7	1125 402
SK 50	40	300	3,7	1125 403



No. 1125 402

## Rundlaufprüfdorne für Steilkegelspindeln

## Concentricity test plug gauge for steep taper spindles



- ▶ DIN 69871
- ▶ Lehenstahl gehärtet
- ▶ Rundlaufgenauigkeit und Zylindrizität 0,003 mm
- ▶ Lieferung im Holzetui inkl. Werkskalibrierschein

- ▶ DIN 69871
- ▶ Hardened tool steel
- ▶ Concentricity and cylindricity 0.003 mm
- ▶ Delivered in wooden box with works calibration certificate

Größe Size	Ø mm	l mm	kg	Nº
SK 30	32	200	1,1	1125 601
SK 40	40	320	2,8	1125 602
SK 50	40	320	4,6	1125 603



No. 1125 602

## Rundlaufprüfdorne für HSK-Spindeln

## Concentricity test plug gauge for HSK spindles



- ▶ DIN 69893
- ▶ Lehenstahl gehärtet
- ▶ Rundlaufgenauigkeit und Zylindrizität 0,003mm
- ▶ Lieferung im Holzetui inkl. Werkskalibrierschein

- ▶ DIN 69893
- ▶ Hardened tool steel
- ▶ Concentricity and cylindricity 0.003 mm
- ▶ Delivered in wooden box with works calibration certificate

Größe Size	Ø mm	l mm	kg	Nº
HSK 25 E	20	140	0,5	1125 700
HSK 32 A	24	180	0,6	1125 701
HSK 40 A	24	180	0,7	1125 702
HSK 50 A	32	236	1,4	1125 703
HSK 63 A	40	346	3,0	1125 704
HSK 80 A	40	346	3,4	1125 705
HSK 100 A	40	349	4,3	1125 706



No. 1125 702

## Rundlaufprüfdorne nach MAS-BT

## Concentricity test plug gauge for MAS-BT spindles



- ▶ JIS B6339
- ▶ Lehenstahl gehärtet
- ▶ Rundlaufgenauigkeit und Zylindrizität 0,003mm
- ▶ Lieferung im Holzetui inkl. Werkskalibrierschein

- ▶ JIS B6339
- ▶ Hardened tool steel
- ▶ Concentricity and cylindricity 0.003 mm
- ▶ Delivered in wooden box with works calibration certificate

Größe Size	Ø mm	l mm	kg	Nº
BT 40	40	320	2,8	1125 801
BT 50	40	320	4,6	1125 802



No. 1125 801



## Rundlaufprüfdorne mit Messkugel

## Concentricity test plug gauge with measuring ball

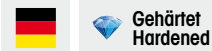

- ▶ DIN siehe Tabelle
- ▶ Lehnstahl gehärtet
- ▶ Rundlaufgenauigkeit Kegel zur Messkugel < 0,01mm
- ▶ Lieferung im Holzetui inkl. Werkskalibrierschein

- ▶ DIN view table
- ▶ Hardened tool steel
- ▶ Concentricity taper to ball < 0.01mm
- ▶ Delivered in wooden box with works calibration certificate

Größe Size	DIN	Ø mm	l-l mm	W kg	Nº
SK 30	69871	30	200	1,2	1125 911
SK 40	69871	30	150	1,0	1125 912
SK 50	69871	30	150	1,0	1125 913
HSK 32 A	69893	30	150	1,0	1125 901
HSK 40 A	69893	30	150	1,0	1125 902
HSK 50 A	69893	30	150	1,0	1125 903
HSK 63 A	69893	30	150	1,0	1125 904
HSK 100 A	69893	30	150	1,0	1125 905
BT 40	JIS B6339	30	150	1,0	1125 921
BT 50	JIS B6339	30	150	1,0	1125 922



No. 1125 901

## Spannkraftprüfer

## Resilience tester



- ▶ DIN siehe Tabelle
- ▶ zum Prüfen der Einzugskräfte von Spannsystemen in Maschinenspindeln
- ▶ Ablesung in kN
- ▶ Lieferung im Koffer inkl. Messuhr und Werkskalibrierschein

- ▶ DIN view table
- ▶ For checking the tensile strengths of clamping systems in machine spindles
- ▶ Reading in kN
- ▶ Delivered in a box including dial gauge and works calibration certificate

Größe Size	DIN	W kN	W kg	Nº
SK 30	2080 / 69871	1 - 15	1,6	1113 301
SK 40	2080 / 69871	2 - 18	1,9	1113 302
SK 50	2080 / 69871	5 - 40	4,5	1113 303
HSK 25	69893	0,5 - 10	1,2	1114 300
HSK 32	69893	1 - 15	1,3	1114 301
HSK 40	69893	2 - 20	1,4	1114 302
HSK 50	69893	2 - 25	1,6	1114 303
HSK 63	69893	5 - 40	2,2	1114 304
HSK 80	69893	10 - 50	4,1	1114 305
HSK 100	69893	10 - 70	5,9	1114 306
BT 40	JIS B6339	2 - 18	1,9	1115 301
BT 50	JIS B6339	5 - 40	4,5	1115 302



No. 1114 304

## Prüfdorne zwischen Spitzen

## Test plug gauges between centres



- ▶ Werksnorm
- ▶ Lehnstahl gehärtet
- ▶ Rundlaufgenauigkeit und Zylindrizität 0,002mm
- ▶ Lieferung einzeln verpackt

- ▶ Works standard
- ▶ Hardened tool steel
- ▶ Concentricity accuracy and cylindricity 0.002mm
- ▶ Delivered in individual packages



No. 1127 101

1127 1.. :  
Prüfdorne

1127 1.. :  
Test plug gauges

1127 5.. :  
Holzetui

1127 5.. :  
Wooden box

1 Andere Abmessungen sowie hartverchromte Ausführungen auf Anfrage.

1 Other dimensions and hard chrome versions on request.

l-l mm	Ø mm	W mm	W kg	Nº	Nº
300	32	0,002	1,9	1127 101	1127 501
400	35	0,002	3,1	1127 102	1127 502
500	40	0,002	5,0	1127 103	1127 503
600	50	0,003	9,4	1127 104	1127 504

## Werkzeuvoreinstellgeräte

## Tool pre-setting instrument



**sylvac**  
System

- ▶ Werksnorm
- ▶ Sylvac System
- ▶ Zum Messen und Einstellen von Werkzeugen
- ▶ Werkzeugaufnahme drehbar
- ▶ LCD-Display, Auflösung 0,01mm
- ▶ mit Präzisionsmessuhren (0,01mm) für X- und Z-Achse
- ▶ X- und Z-Achse mit Schnellverstellung durch zentralen Druckknopf am Gehäuse, Feineinstellung mit Handrad
- ▶ Standardaufnahme SK 40
- ▶ Lieferung inkl. Holzetui und 2 Stück Messuhren

### Funktion:

- ▶ Ein/Aus
- ▶ mm/inch Umschaltung
- ▶ O-Punkt an jeder Position
- ▶ ± Preset Funktion
- ▶ Datenausgang Opto

### Anwendung:

- ▶ Messen durch berührendes Abtasten der Schneide
- ▶ Präzisionsgeführte Taster für X- und Z-Achse
- ▶ Präzisionsmessuhren als Nullindikator
- ▶ Konstanter Messdruck <1N zum Schutz der Schneide
- ▶ Ideal für Bestimmung von Durchmesser und Länge

- ▶ Works standard
- ▶ Sylvac System
- ▶ Measuring and adjusting tools
- ▶ Tool holding device rotating
- ▶ LCD display, reading 0.01mm
- ▶ With precision dial gauges (0.01mm) for X- and Z-axis
- ▶ X- and Z-axis with quick adjustment with central push button, fine adjustment with hand wheel
- ▶ Standard tool holding device SK 40
- ▶ Delivered in wooden box incl. 2 pcs. dial gauges

### Functions:

- ▶ On/Off
- ▶ mm/inch commutation
- ▶ Zero setting at any position
- ▶ ± Preset function
- ▶ Data output Opto

### Application:

- ▶ contact measurement at the tool edge
- ▶ precision guided probes for x- and z-axis
- ▶ precision dial gauge s as O-point indicator
- ▶ constant measuring force < 1N to protect the tool edge
- ▶ perfect for determination of diameter and length

SK	X-Achse mm	Z-Achse mm	L mm	H mm	∠ / Ⓞ mm	<∠ mm	⚖ kg	Nº
40	160 (Ø320)	320	584	520	0,02	0,01	25,0	1465 101
40	260 (Ø520)	520	684	848	0,03	0,01	30,0	1465 102

Andere Werkzeugaufnahmen auf Anfrage. / Other tool holders on request.

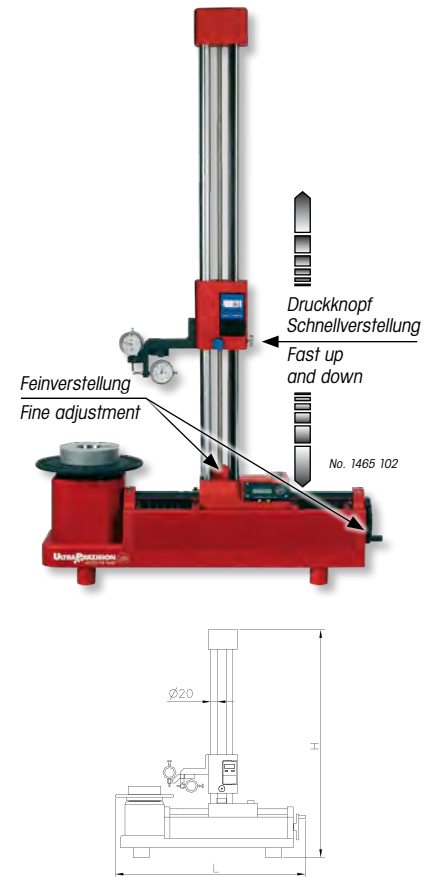

## Werkzeuvoreinstellgeräte

## Tool pre-setting instruments



**sylvac**  
System

- ▶ Werksnorm
- ▶ Sylvac System
- ▶ Zum Messen und Einstellen von Werkzeugen
- ▶ Werkzeugaufnahme drehbar
- ▶ LCD-Display, Auflösung 0,01mm
- ▶ mit Präzisionsmessuhr (0,01mm) für X- und Z-Achse
- ▶ X- und Z-Achse mit Schnellverstellung durch zentralen Druckknopf am Gehäuse, Feineinstellung mit Handrad
- ▶ Standardaufnahme SK 40
- ▶ Führungselemente mit Faltenbalgabdeckung
- ▶ Lieferung inkl. Holzetui und 1 Stück Messuhr

### Funktion:

- ▶ Ein/Aus
- ▶ mm/inch Umschaltung
- ▶ O-Punkt an jeder Position
- ▶ ± Preset Funktion
- ▶ Datenausgang Opto

### Anwendung:

- ▶ Messen durch berührendes Abtasten der Schneide
- ▶ Ein präzisionsgeführter HM-Taster für X- und Z-Achse
- ▶ Präzisionsmessuhr als Nullindikator
- ▶ Konstanter Messdruck <1N zum Schutz der Schneide
- ▶ Ideal für Bestimmung von Durchmesser und Länge

- ▶ Works standard
- ▶ Sylvac System
- ▶ Measuring and adjusting tools
- ▶ Tool holding device rotating
- ▶ LCD display, reading 0.01mm
- ▶ With precision dial gauge (0.01mm) for X- and Z-axis
- ▶ X- and Z-axis with quick adjustment with central push button, fine adjustment with hand wheel
- ▶ Standard tool holding device SK 40
- ▶ Axis protection by harmonica type cover
- ▶ Delivered in wooden box incl. 1 pcs. dial gauge

### Functions:

- ▶ On/Off
- ▶ mm/inch commutation
- ▶ Zero setting at any position
- ▶ ± Preset function
- ▶ Data output Opto

### Application:

- ▶ contact measurement at the tool edge
- ▶ precision guided probes for x- and z-axis
- ▶ precision dial gauge s as O-point indicator
- ▶ constant measuring force < 1N to protect the tool edge
- ▶ perfect for determination of diameter and length

SK	X-Achse mm	Z mm	L mm	H mm	∠ / Ⓞ mm	<∠ mm	⚖ kg	Nº
40	160 (Ø320)	320	584	758	0,02	0,01	27,0	1465 201
40	260 (Ø520)	450	684	888	0,02	0,01	32,0	1465 202

Andere Werkzeugaufnahmen auf Anfrage. / Other tool holders on request.

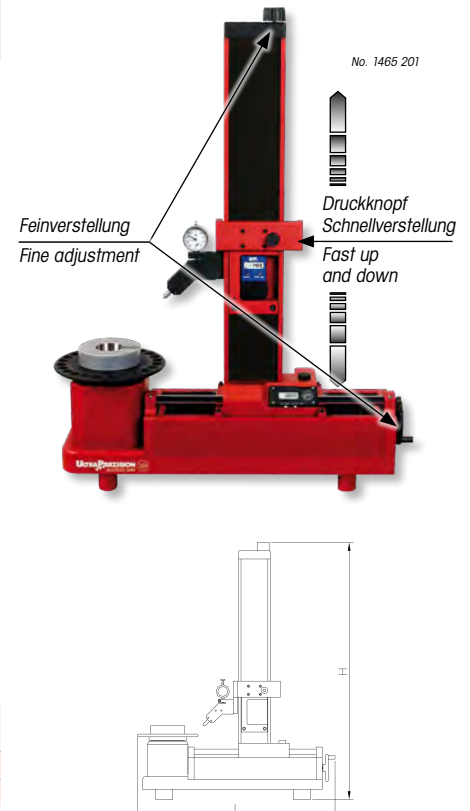

**SK Messgerät**

**SK measuring instrument**



- ▶ DIN 2080 / DIN 69871
- ▶ zum Prüfen der Funktionsmaße
- ▶ Vergleichsmessung mit Einstellhorn
- ▶ Lieferung im Holzetui inkl. 3 Feinzeiger, 1 Kleinmessuhr

**Prüfparameter:**

- ▶ Kegeldurchmesser groß
- ▶ Kegeldurchmesser klein
- ▶ Konizität
- ▶ Geradheit der Mantellinie
- ▶ Flanschabstand

- ▶ DIN 2080 / DIN 69871
- ▶ For checking functional dimensions
- ▶ Comparative measurement with setting plug
- ▶ Delivered in a wooden box including 3 comparator gauges and 1 dial gauge

**Test parameters:**

- ▶ Taper diameter large
- ▶ Taper diameter small
- ▶ Conicity
- ▶ Straightness of the surface line
- ▶ Flange distance

**1113 1. :**

SK-Messgerät

**1113 1. :**

SK measuring instrument

**1113 2. :**

SK-Einstellhorn inkl. Werkskalibrierschein und Holzetui

**1113 2. :**

SK setting plug with works calibration certificate and wooden box

**I** Mit Sonderzubehör können zusätzlich Greiferrille, sowie Rundlauf der Werkzeugaufnahme geprüft werden.

**I** Tracking groove and concentricity of the tool fitting can be additionally checked with special accessories.

Größe Size	⚖ kg	Nº	⚖ kg	Nº
SK 30	4,8	1113 101	0,6	1113 201
SK 40	5,7	1113 102	1,1	1113 202
SK 50	8,7	1113 103	2,6	1113 203



No. 1113 102



Sonderzubehör  
Special accessories

**HSK Messgerät**

**HSK measuring instrument**



- ▶ DIN 69893
- ▶ zum Prüfen der Funktionsmaße
- ▶ Vergleichsmessung mit Einstellhorn
- ▶ Lieferung im Holzetui inkl. 2 Feinzeiger, 1 Messuhr

**Prüfparameter:**

- ▶ Kegeldurchmesser groß
- ▶ Kegeldurchmesser klein
- ▶ Spannschultermaß
- ▶ Auswerfmaß

- ▶ DIN 69893
- ▶ For checking functional dimensions
- ▶ Comparative measurement with setting plug
- ▶ Delivered in a wooden box including 2 comparator gauges and 1 dial gauge

**Test parameters:**

- ▶ Taper diameter large
- ▶ Taper diameter small
- ▶ Clamping shoulder dimensions
- ▶ Ejection face depth

**1114 1. :**

HSK-Messgerät

**1114 1. :**

HSK measuring instrument

**1114 2. :**

HSK-Einstellhorn inkl. Werkskalibrierschein und Holzetui

**1114 2. :**

HSK setting plug with works calibration certificate and wooden box

**I** Mit Sonderzubehör können zusätzlich Greiferrille, sowie Rundlauf der Werkzeugaufnahme geprüft werden.

**I** Tracking groove and concentricity of the tool fitting can be additionally checked with special accessories.

Größe Size	⚖ kg	Nº	⚖ kg	Nº
HSK 25	3,4	1114 100	0,4	1114 200
HSK 32	3,6	1114 101	0,5	1114 201
HSK 40	3,8	1114 102	0,6	1114 202
HSK 50	3,9	1114 103	0,9	1114 203
HSK 63	4,1	1114 104	1,1	1114 204
HSK 80	6,4	1114 105	1,7	1114 205
HSK 100	8,9	1114 106	1,8	1114 206



No. 1114 102



No. 1114 204

## Pneumatische Kegelmessdome und Kegelmesshülsen

## Pneumatic taper plug gauges and taper sleeves



**NEW**



**Gehärtet  
Hardened**

- ▶ Werksnorm
- ▶ Hochpräzise, schnelle und sichere Prüfung von Innen- und Außenkegeln
- ▶ Messflächen aus Spezialstahl gehärtet
- ▶ Lieferung einzeln verpackt

- ▶ Works standard
- ▶ High-precision, quick and reliable control of internal and external
- ▶ Measuring surfaces made of hardened special steel
- ▶ Delivered in individual packages



*Konverter (Wandler)  
Converter (transformer)*



*Messrechner OctaGauge  
Measuring computer OctaGauge*

### Anwendung:

- ▶ Zur schnellen und sicheren Prüfung von Kegelmesswinkel, Kegelform, Schleifaufmaße etc.
- ▶ Kegelmessgeräte für SK, BT, MK, ER, HSK sind standardmäßig lieferbar

### Vorteil:

- ▶ Hohe Genauigkeit und Wiederholbarkeit der Messwerte, Bediener unabhängig
- ▶ Schäden am Werkstück werden verhindert
- ▶ Messstellen werden durch die ausströmende Druckluft gereinigt
- ▶ Unempfindlich gegenüber äußeren Einflüssen wie z.B. Temperatur, Luftdruck etc.
- ▶ Hohe Verschleißfestigkeit
- ▶ Geringer Wartungsaufwand, weitgehend verschleißfrei

### Handhabung:

- ▶ Die Voreinstellung erfolgt über einen Einstellmeister.
- ▶ Die Abweichung vom Werkstück zum Einstellmeister wird am Anzeigergerät abgelesen.
- ▶ Die Ablesung erfolgt analog durch einen pneumatischen Konverter (Ablesung 0,5µ) oder wahlweise elektronisch mit einem Messrechner OctaGauge (Ablesung 0,1µ). Optional mit Datenübertragung, Auswertung und Archivierung der Messdaten.

### Sonderlösungen:

- ▶ Wir liefern jede Art von Sonderprüfdornen und -hülsen, auch für zylindrische Bohrungen und Wellen, für Ihren speziellen Bedarfsfall.

Zur Angebotserstellung bitten wir um Ihre Anfragen mit Werkstückzeichnungen, gerne prüfen wir die Machbarkeit.

### Application:

- ▶ For a quick and reliable control of taper angle, taper shape, grinding allowance etc.
- ▶ Taper measuring instruments for SK, BT, MK, ER, HSK are available as standard

### Advantage:

- ▶ High precision and repeatability of the measured values, user independent results
- ▶ Damages to the work piece are avoided
- ▶ The measuring points are cleaned by the outflowing compressed air
- ▶ Insensitive to external influences such as temperature, compressed air etc.
- ▶ High resistance to wear
- ▶ Low maintenance requirements, almost free of wear

### Handling:

- ▶ Pre-setting is performed by means of a setting master.
- ▶ The deviation from the work piece to the setting master is read out on the display unit.
- ▶ The reading is analogue, through a pneumatic converter (reading 0.5µ) or optionally electronic with a measuring computer OctaGauge (reading 0.1µ). Optionally with data transmission, evaluation and storage the measuring results.

### Special solutions:

- ▶ We supply each type of special test gauges and sleeves, for cylindrical bores and shafts too, for your special requirement.

We would ask you to send us your enquiries together with the work-piece drawings, so to enable us to check the feasibility and to prepare the requested quotations.

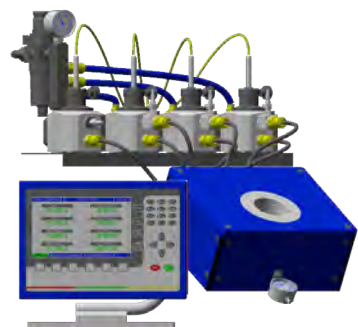

*Mehrstellenmessplatz mit  
Messrechner OctaGauge*

*Multi-position measuring system with  
measuring computer OctaGauge*



## Einstellringe aus Hartmetall

## Setting ring gauges, tungsten carbide



- ▶ DIN 2250-C
- ▶ Lehenkörper aus Stahl, Messflächeneinsatz aus Hartmetall
- ▶ Lieferung einzeln verpackt

- ▶ DIN 2250-C
- ▶ Gauge body in steel, measuring face insert in tungsten carbide
- ▶ Delivered in individual packages

**!** Für Zwischenmaße und zahlenmäßige Toleranzangaben werden Zuschläge berechnet.

**!** Intermediate dimensions and numerical tolerances have extra charges.

**!** Andere Ausführungen auf Anfrage.

**!** Other types on request.

Ø mm	Nº	Ø mm	Nº	Ø mm	Nº	Ø mm	Nº	Ø mm	Nº	Ø mm	Nº
1	1132 501	7	1132 515	13	1132 521	19	1132 527	25	1132 533	33	1132 539
2	1132 505	8	1132 516	14	1132 522	20	1132 528	26	1132 534	34	1132 540
3	1132 509	9	1132 517	15	1132 523	21	1132 529	27	1132 535	35	1132 541
4	1132 511	10	1132 518	16	1132 524	22	1132 530	28	1132 536	36	1132 542
5	1132 513	11	1132 519	17	1132 525	23	1132 531	30	1132 537	37	1132 543
6	1132 514	12	1132 520	18	1132 526	24	1132 532	32	1132 538	38	1132 544
										> 38	auf Anfrage on request



No. 1132 5..

## Einstellringe aus Keramik

## Setting ring gauges, ceramic



- ▶ Werksnorm
- ▶ extrem hart und korrosionsbeständig, absolut verschleißfest
- ▶ Lieferung einzeln verpackt

- ▶ Works standard
- ▶ Extremely hard, anti-corrosive and absolutely wear-resistant
- ▶ Delivered in individual packages

**!** Ø 2 – 45mm auf Anfrage.  
Zur Angebotsstellung benötigen wir den Nenndurchmesser und die Toleranz.

**!** Ø 2 – 45mm on request.  
For the preparation of a quotation please specify the required nominal diameter and the tolerance.



Auf Anfrage / on request

## Schutzbox zur Aufbewahrung von Lehringen

## Protection box for storage of ring gauges



- ▶ aus Polypropylen (transparent)
- ▶ mit sicherem Scharnierverschluss
- ▶ feuchtigkeits- und ölresistent
- ▶ wiederverschließbar und mehrfach verwendbar

- ▶ Polypropylene (transparent)
- ▶ With hinged lid
- ▶ Humidity and oil resistant
- ▶ Re-usable

für / for Ø mm	l mm	Nº
≤ 5	22x22x8	UB22x8
> 5 – 9	35x35x12	UB35x12
> 9 – 19	47x47x19	UB47x19
> 19 – 31	67x67x26	UB67x26



**Grensrachenlehren**

**Limit snap gauges**



**TOP**



**Gehärtet  
Hardened**

- ▶ Messflächen gehärtet
- ▶ > 1,8mm im Gesenk geschmiedet
- ▶ ISO Toleranzfelder A-ZC, Qualität 7-13
- ▶ Lieferung einzeln verpackt

- ▶ Hardened measuring faces
- ▶ > 1.8 mm drop forged
- ▶ ISO tolerance A-ZC, quality 7-13
- ▶ Delivered in individual packages

**1140 1.. :**

DIN 2230, Grensrachenlehren doppelmäulig

**1140 1.. :**

DIN 2230, Limit snap gauges with double-ended jaws

**1141 1.. :**

DIN 2231, Grensrachenlehren einmäulig, Gutseite und Ausschusseite in einem Rachen

**1141 1.. :**

DIN 2231, Limit snap gauges with single-ended jaws, GO and NO-GO sides on one side

**!** Für Zwischenmaße, zahlenmäßige Toleranz sowie Qualität 6 und feiner werden Zuschläge berechnet.

**!** Intermediate dimensions, numerical tolerances and quality 6 and finer have extra charges.

**!** Hartverchromte oder hartmetallbestückte Ausführungen auf Anfrage.

**!** Hard chrome-plated or tungsten carbide-tipped models on request.



No. 1140 1..



No. 1141 1..

Ø mm	Nº	Nº	Ø mm	Nº	Nº	Ø mm	Nº	Nº	Ø mm	Nº	Nº
0,5	1140 101	1141 101	11	1140 120	1141 120	30	1140 139	1141 139	58	1140 158	1141 158
0,8	1140 102	1141 102	12	1140 121	1141 121	31	1140 140	1141 140	60	1140 159	1141 159
1,0	1140 103	1141 103	13	1140 122	1141 122	32	1140 141	1141 141	62	1140 160	1141 160
1,2	1140 104	1141 104	14	1140 123	1141 123	33	1140 142	1141 142	65	1140 161	1141 161
1,5	1140 105	1141 105	15	1140 124	1141 124	34	1140 143	1141 143	68	1140 162	1141 162
1,8	1140 106	1141 106	16	1140 125	1141 125	35	1140 144	1141 144	70	1140 163	1141 163
2	1140 107	1141 107	17	1140 126	1141 126	36	1140 145	1141 145	72	1140 164	1141 164
2,5	1140 108	1141 108	18	1140 127	1141 127	37	1140 146	1141 146	75	1140 165	1141 165
2,8	1140 109	1141 109	19	1140 128	1141 128	38	1140 147	1141 147	78	1140 166	1141 166
3	1140 110	1141 110	20	1140 129	1141 129	40	1140 148	1141 148	80	1140 167	1141 167
3,5	1140 111	1141 111	21	1140 130	1141 130	42	1140 149	1141 149	82	1140 168	1141 168
4	1140 112	1141 112	22	1140 131	1141 131	44	1140 150	1141 150	85	1140 169	1141 169
4,5	1140 113	1141 113	23	1140 132	1141 132	45	1140 151	1141 151	88	1140 170	1141 170
5	1140 114	1141 114	24	1140 133	1141 133	46	1140 152	1141 152	90	1140 171	1141 171
6	1140 115	1141 115	25	1140 134	1141 134	47	1140 153	1141 153	92	1140 172	1141 172
7	1140 116	1141 116	26	1140 135	1141 135	48	1140 154	1141 154	95	1140 173	1141 173
8	1140 117	1141 117	27	1140 136	1141 136	50	1140 155	1141 155	98	1140 174	1141 174
9	1140 118	1141 118	28	1140 137	1141 137	52	1140 156	1141 156	100	1140 175	1141 175
10	1140 119	1141 119	29	1140 138	1141 138	55	1140 157	1141 157			

**Grensrachenlehren, flache Ausführung**

**Limit snap gauges, flat model**



**Gehärtet  
Hardened**

- ▶ Lehenstahl gehärtet
- ▶ Lieferung einzeln verpackt

- ▶ Hardened tool steel
- ▶ Delivered in individual packages

**1143 1.. :**

DIN 2235 für Einstichdurchmesser auf Anfrage

**1143 1.. :**

DIN 2235 for recess diameter on request

**1144 1.. :**

DIN 6799/471 für Einstichdurchmesser und Einstichbreite auf Anfrage

**1144 1.. :**

DIN 6799/471 for recess diameter and recess width on request



No. 1143 1..



No. 1144 1..

## Grenzrachenlehren

## Limit snap gauges



**Gehärtet  
Hardened**

- ▶ Werksnorm
- ▶ Messflächen gehärtet
- ▶ ISO Toleranzfelder A-ZC, Qualität 7-13
- ▶ Ø-Stufung 1mm
- ▶ Lieferung einzeln verpackt (Nr. 1151 1.. paarweise)

- ▶ Works standard
- ▶ Hardened measuring faces
- ▶ ISO tolerance A-ZC, quality 7-13
- ▶ Ø-step 1mm
- ▶ Delivered in individual packages (No. 1151 1.. in pairs)

### 1150 101 – 1150 107 :

im Gesenk geschmiedet,  
Gut- und Ausschusseite in einem Rachen

### 1150 101 – 1150 107 :

Drop forged,  
GO and NO-GO sides on one side

### 1150 108 – 1150 119 :

Messflächen aus Lehrenstahl, Handwärmeschutz  
Gut- und Ausschusseite in einem Rachen

### 1150 108 – 1150 119 :

Steel measuring faces, insulated pads  
GO and NO-GO sides on one side

### 1151 101 – 1151 107 :

im Gesenk geschmiedet,  
Gut- und Ausschusseite getrennt (Paar)

### 1151 101 – 1151 107 :

Drop forged,  
GO and NO-GO separate (pairs)

### 1151 108 – 1151 119 :

Messflächen aus Lehrenstahl, Handwärmeschutz  
Gut- und Ausschusseite getrennt (Paar)

### 1151 108 – 1151 119 :

Steel measuring faces, insulated pads  
GO and NO-GO separate (pairs)

! Für Zwischenmaße, zahlenmäßige Toleranz sowie Qualität 6 und feiner werden Zuschläge berechnet.

! Intermediate dimensions, numerical tolerances and quality 6 and finer have extra charges.

! Hartverchromte oder hartmetallbestückte Ausführungen auf Anfrage.

! Hard chrome-plated or tungsten carbide-tipped models on request.

Ø mm	Nº	Nº
>100 – 115	1150 101	1151 101
>115 – 130	1150 102	1151 102
>130 – 145	1150 103	1151 103
>145 – 160	1150 104	1151 104
>160 – 175	1150 105	1151 105
>175 – 190	1150 106	1151 106
>190 – 205	1150 107	1151 107

Ø mm	Nº	Nº
>205 – 220	1150 108	1151 108
>220 – 240	1150 109	1151 109
>240 – 265	1150 110	1151 110
>265 – 290	1150 111	1151 111
>290 – 315	1150 112	1151 112
>315 – 340	1150 113	1151 113
>340 – 365	1150 114	1151 114

Ø mm	Nº	Nº
>365 – 390	1150 115	1151 115
>390 – 415	1150 116	1151 116
>415 – 445	1150 117	1151 117
>445 – 475	1150 118	1151 118
>475 – 500	1150 119	1151 119



No. 1150 1..



No. 1151 1..

## Prüflehren für Grenzrachenlehren Messscheiben

## Check gauges for limit snap gauges Setting discs



**Gehärtet  
Hardened**

- ▶ DIN 2253
- ▶ Lehrenstahl gehärtet
- ▶ Lieferung einzeln verpackt

- ▶ DIN 2253
- ▶ Hardened tool steel
- ▶ Delivered in individual packages

### 1158 1.. :

bis Ø100mm vollzylindrische Messscheiben auf Anfrage

### 1158 1.. :

Up to Ø100mm fully cylindrical gauges discs on request

### 1158 2.. :

über Ø100mm flache Prüfstäbe  
mit zylindrischen Messflächen auf Anfrage

### 1158 2.. :

Over Ø100mm flat  
with cylindrical measuring faces on request



No. 1158 1..



No. 1158 2..

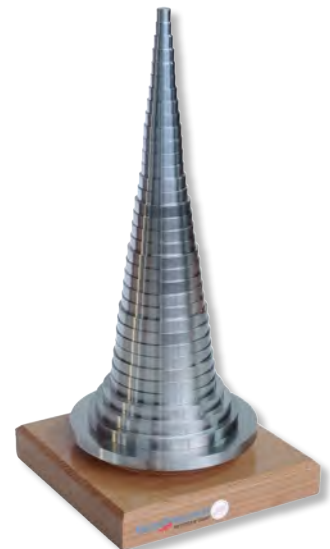

Messscheiben-Pyramiden auf Holzsockel montiert, Satzzusammenstellung nach Ihren Vorgaben auf Anfrage.

Setting discs pyramids mounted on a wooden base, set combinations according to your requirement on request.



## Grensrachenlehren verstellbar

## Limit snap gauges, adjustable



TOP



Gehärtet  
Hardened

- ▶ Werksnorm
- ▶ Messflächen aus Lehnstahl gehärtet
- ▶ Einmäulig, Gutseite und Ausschusseite in einem Rachen
- ▶ 4 runde Messflächen, verstellbar
- ▶ Lieferung einzeln verpackt

- ▶ Works standard
- ▶ Hardened tool steel measuring faces
- ▶ Single-ended jaws, GO and NO-GO sides on one side
- ▶ 4 round measuring faces, adjustable
- ▶ Delivered in individual packages

! Voreingestellte Lehren auf Anfrage.

! Adjusted gauges on request.



No. 1154 1..

mm	Nº	mm	Nº	mm	Nº	mm	Nº
0 – 13	1154 101	51 – 64	1154 105	114 – 133	1154 109	203 – 229	1154 113
13 – 25	1154 102	64 – 76	1154 106	133 – 152	1154 110		
25 – 38	1154 103	76 – 95	1154 107	152 – 178	1154 111		
38 – 51	1154 104	95 – 114	1154 108	178 – 203	1154 112		

## Grensrachenlehren verstellbar

## Limit snap gauges, adjustable



TOP



Gehärtet  
Hardened

- ▶ Werksnorm
- ▶ Messflächen aus Lehnstahl gehärtet
- ▶ Einmäulig, Gutseite und Ausschusseite in einem Rachen
- ▶ 2 Messflächen verstellbar und 1 Messbacke fest
- ▶ Lieferung einzeln verpackt

- ▶ Works standard
- ▶ Hardened tool steel measuring faces
- ▶ Single-ended jaws, GO and NO-GO sides on one side
- ▶ 2 adjustable measuring faces and 1 fixed measuring jaw
- ▶ Delivered in individual packages

! Voreingestellte Lehren auf Anfrage.

! Adjusted gauges on request.



No. 1155 1..

mm	Nº	mm	Nº	mm	Nº	mm	Nº
0 – 6	1155 101	51 – 57	1155 109	101 – 108	1155 115	152 – 163	1155 121
6 – 13	1155 102	57 – 63	1155 110	108 – 114	1155 116	163 – 175	1155 122
13 – 19	1155 103	63 – 70	1155 111	114 – 120	1155 117	175 – 188	1155 122x
19 – 25	1155 104	70 – 76	1155 112	120 – 127	1155 117x	188 – 200	1155 123
25 – 32	1155 105	76 – 82	1155 113	127 – 133	1155 118	200 – 213	1155 124
32 – 38	1155 106	82 – 89	1155 113x	133 – 139	1155 118x	213 – 225	1155 125
38 – 44	1155 107	89 – 95	1155 114	139 – 146	1155 119	225 – 238	1155 126
44 – 51	1155 108	95 – 101	1155 114x	146 – 152	1155 120	238 – 250	1155 127

## Passameter verstellbar mit Anzeige

## Passameter adjustable with indicator



Hartmetall  
Tungsten carbide

- ▶ Werksnorm
- ▶ Messflächen hartmetallbestückt Ø 10mm
- ▶ Metallbügel mit Handwärmeschutz
- ▶ Zentriersstütze und Abhebevorrichtung
- ▶ Freihub 2,5mm
- ▶ Toleranzmarken einstellbar
- ▶ spritzwassergeschützt
- ▶ Lieferung im Etui

- ▶ Works standard
- ▶ Tungsten carbide-tipped measuring faces Ø 10mm
- ▶ Metal frame with heat-insulated handle
- ▶ Centre supports and lifting device
- ▶ Free lift 2.5mm
- ▶ Adjustable tolerance marks
- ▶ Splash-water protected
- ▶ Delivered in a case

1160 1.. :  
Ablesung 1µ, Anzeigebereich ±70µ

1160 1.. :  
Reading 1µ, Indicating range ±70µ

1160 2.. :  
Ablesung 2µ, Anzeigebereich ±150µ

1160 2.. :  
Reading 2µ, Indicating range ±150µ



No. 1160 103

No. 1160 101

mm	kg	Nº	Nº	mm	kg	Nº	Nº
0 – 25	0,8	1160 101	1160 201	75 – 100	1,3	1160 104	1160 204
25 – 50	1,0	1160 102	1160 202	100 – 125	1,6	-	1160 205
50 – 75	1,2	1160 103	1160 203	125 – 150	1,7	-	1160 206

## Digital-Universalrachenlehren SNAPMIC

## Digital universal snap gauges SNAPMIC



- ▶ Werksnorm
- ▶ Sylvac System
- ▶ großes LCD Display
- ▶ Hartmetallmessflächen Ø8mm
- ▶ Zentrierstütze und Abhebevorrichtung
- ▶ Freihub 7 – 8mm
- ▶ konstante Messkraft
- ▶ Griff mit Handwärmeschutz
- ▶ Lieferung ohne Einstellmaß in Kunststoffbox

### Funktionen:

- ▶ Ein/Aus
- ▶ mm/inch Umschaltung
- ▶ 0-Punkt an jeder Position
- ▶ Ablesung umschaltbar 0,01/0,001mm
- ▶ Preset Funktion
- ▶ 2 Referenzwertspeicher
- ▶ Hold Funktion
- ▶ Datenausgang Opto

! Spezielle Messflächen für Gewinde-, Verzahnungs-, Rillennmessung usw. auf Anfrage.

- ▶ Works standard
- ▶ Sylvac System
- ▶ Large LCD display
- ▶ Tungsten carbide-tipped measuring faces Ø8mm
- ▶ Centre supports and lifting device
- ▶ Free lift 7 – 8mm
- ▶ Constant measuring force
- ▶ Heat-insulated handle
- ▶ Delivered without setting gauge in plastic box

### Functions:

- ▶ On/Off
- ▶ mm/inch commutation
- ▶ Zero setting at any position
- ▶ Reversible reading 0.01/0.001mm
- ▶ Preset function
- ▶ 2 preset memories
- ▶ Hold function
- ▶ Data output Opto

! Special measuring faces for thread-, spline-, groove measuring etc. on request.

mm	mm	mm	kg	Nº
0 – 30	0,0003	0,001	0,8	1162 101
30 – 60	0,0006	0,001	1,0	1162 102
Halter für Rachenlehre SNAPMIC / Holder for Snap gauges SNAPMIC				1161 521
Datenkabel RS 232 (2m) / Data cable RS 232 (2m)				1850 203
Datenkabel USB (2m) / Data cable USB (2m)				1850 204



**BOWERS GROUP**



No. 1162 101

No. 1161 521

## Universal Rachenlehren SNAPMATIC

## Universal snap gauges SNAPMATIC



- ▶ Werksnorm
- ▶ Hartmetallmessflächen 16x13mm
- ▶ Amboss verschiebbar
- ▶ Zentrierstütze und Abhebevorrichtung
- ▶ Freihub 0,5mm
- ▶ konstante Messkraft
- ▶ Griff mit Handwärmeschutz
- ▶ Messhauaufnahme Ø8mm
- ▶ Lieferung ohne Messuhr in Kartonbox

! Spezielle Messflächen für Gewinde-, Verzahnungs-, Rillennmessung usw. auf Anfrage.

- ▶ Works standard
- ▶ Tungsten carbide-tipped measuring faces 16x13mm
- ▶ Anvil moveable
- ▶ Centre supports and lifting device
- ▶ Free lift 0.5mm
- ▶ Constant measuring force
- ▶ Heat-insulated handle
- ▶ Dial mounting hole Ø8mm
- ▶ Delivered without dial gauge in cardboard box

! Special measuring faces for thread-, spline-, groove measuring etc. on request.

mm	mm	mm	mm	kg	Nº
0 – 25	x16	0,0001	0,002	0,5	1161 101
25 – 50	x16	0,0001	0,002	0,5	1161 102
50 – 75	x16	0,0001	0,003	0,5	1161 103
75 – 100	x16	0,0001	0,003	0,5	1161 104
100 – 125	x16	0,0001	0,004	0,6	1161 105
125 – 150	x16	0,0001	0,004	0,6	1161 106
Halter für Rachenlehren SNAPMATIC / Holder for Snap gauges SNAPMATIC					1161 521
Digital-Messuhr 0,001mm (mit Bluetooth) / Digital dial indicators 0.001mm (with Bluetooth)					1301 105b
Digital-Messuhr 0,001mm / Digital dial indicators 0.001mm					1301 105
Feinzeiger 0,001mm / Comparator gauges 0.001mm					1308 501



**BOWERS GROUP**



No. 1161 102

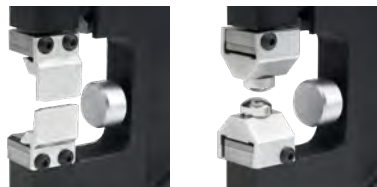

Sondermessflächen auf Anfrage  
Special measuring faces on request

**Digital-Passameter verstellbar**

**Digital Passameter adjustable**

 **NEW**
 **IP65**
 **Hartmetall Tungsten carbide**

- ▶ Werksnorm
- ▶ Schutzart IP 65
- ▶ großes LCD Display, drehbar 360°
- ▶ Hartmetallmessflächen Ø 10mm
- ▶ Parallelität 0,0005mm
- ▶ Ebenheit 0,0003mm
- ▶ Zentrierstütze und Abhebevorrichtung
- ▶ Freihub 4mm
- ▶ konstante Messkraft
- ▶ Griff mit Handwärmeschutz
- ▶ Lieferung im Etui

- ▶ Works standard
- ▶ Protection class IP 65
- ▶ Large LCD display, turnable up to 360°
- ▶ Tungsten carbide-tipped measuring faces Ø 10mm
- ▶ Parallelism 0.0005mm
- ▶ Flatness 0.0003mm
- ▶ Centre supports and lifting device
- ▶ Free lift 4mm
- ▶ Constant measuring force
- ▶ Heat-insulated handle
- ▶ Delivered in a case

**Funktionen:**

- ▶ Ein/Aus
- ▶ mm/inch Umschaltung
- ▶ 0-Punkt an jeder Position
- ▶ Ablesung umschaltbar 0,001/0,0001mm
- ▶ Preset Funktion
- ▶ Toleranzwerteingabe
- ▶ Hold Funktion
- ▶ Datenausgang

**Functions:**

- ▶ On/Off
- ▶ mm/inch commutation
- ▶ Zero setting at any position
- ▶ Reversible reading 0.001/0.0001mm
- ▶ Preset function
- ▶ Tolerance input
- ▶ Hold function
- ▶ Data output





No. 1160 50.

mm	inch	mm / inch	kg	Nº
0 – 30	0 – 1	0,01 / .0005 0,001 / .00005	0,9	1160 501
25 – 55	1 – 2	0,01 / .0005 0,001 / .00005	1,1	1160 502
50 – 80	2 – 3	0,01 / .0005 0,001 / .00005	1,3	1160 503

**Feinzeiger-Messschrauben**

**External micrometers with comparator gauge**

 **TOP**
 **Hartmetall Tungsten carbide**

- ▶ DIN 863
- ▶ Feinzeiger DIN 879
- ▶ Ablesung Mikrometer 0,01mm
- ▶ Hartmetallmessflächen Ø8mm
- ▶ Spindelsteigung 0,5mm
- ▶ Spindelklemmung mit Hebel
- ▶ Anlüftung ca. 2,5mm mit Druckknopf
- ▶ konstante Messkraft, federbelasteter Amboss
- ▶ Handwärmeschutz
- ▶ Lieferung im Etui ohne Einstellmaß

- ▶ DIN 863
- ▶ Comparator gauge DIN 879
- ▶ Micrometer reading 0.01mm
- ▶ Tungsten carbide-tipped measuring faces Ø8mm
- ▶ Spindle pitch 0.5mm
- ▶ Spindle clamping with lever
- ▶ Lifting device approx. 2.5mm with push button
- ▶ Constant measuring force, spring-loaded anvil
- ▶ Insulated pads
- ▶ Delivered in a case without setting gauge



No. 2018 201

**2018 2.. :** Ablesung Feinzeiger 0,001mm      **2018 2.. :** Reading comparator 0.001mm

**2018 1.. :** Ablesung Feinzeiger 0,002mm      **2018 1.. :** Reading comparator 0.002mm

**2037 1... :** Einstellmaße      **2037 1... :** Setting gauges

mm	mm	± μ	kg	Nº	Nº
0 – 25	0,001	70	0,7	2018 201	-
25 – 50	0,001	70	0,8	2018 202	2037 101
0 – 25	0,002	140	0,7	2018 101	-
25 – 50	0,002	140	0,8	2018 102	2037 101
50 – 75	0,002	140	0,9	2018 103	2037 102
75 – 100	0,002	140	1,0	2018 104	2037 103
100 – 125	0,002	140	1,2	2018 105	2037 104
125 – 150	0,002	140	1,4	2018 106	2037 105

**Weitere Bügelmessschrauben mit Feinzeiger oder Messuhrablesung in Kapitel 13**  
**Other external micrometers with comparator or dial gauge in chapter 13**

1  
2  
3  
4  
5  
6  
7  
8  
9  
10  
11  
12  
13  
14  
15

## Feinzeiger-Rachenlehren verstellbar

## Comparator snap gauges, adjustable



**Hartmetall  
Tungsten carbide**

$\mu\text{m} \leq 850\text{mm}$

- ▶ Werksnorm
- ▶ Messflächen hartmetallbestückt
- ▶ Parallelität 0,003mm
- ▶ Ebenheit 0,001mm
- ▶ Leichtmetallbügel mit Handwärmeschutz
- ▶ Messuhraufnahme  $\varnothing 8\text{mm}$
- ▶ Lieferung einzeln verpackt ohne Anzeigegerät

- ▶ Works standard
- ▶ Tungsten carbide-tipped measuring faces
- ▶ Parallelism 0.003mm
- ▶ Flatness 0.001mm
- ▶ Light metal frame with heat-insulated handle
- ▶ Dial mounting hole  $\varnothing 8\text{mm}$
- ▶ Delivered in individual packages without indicator

### 1159 101 – 1159 104 :

$\leq 100\text{mm}$  mit Zentrierstütze und Abhebevorrichtung

### 1159 101 – 1159 104 :

$\leq 100\text{mm}$  with centre supports and lifting device

### 1159 105 – 1159 119 :

ohne Zentrierstütze und Abhebevorrichtung

### 1159 105 – 1159 119 :

Without centre supports and lifting device



No. 1159 1..

**!** Zentrierstütze für Geräte 100-400mm auf Anfrage.

**!** Centre supports for gauge 100-400mm on request.

$\mu\text{m}$ mm	$\varnothing$ mm	$\bar{m}$ kg	Nº
0 – 25	15x15	0,3	1159 101
25 – 50	15x15	0,4	1159 102
50 – 75	15x15	0,5	1159 103
75 – 100	15x15	0,7	1159 104
100 – 150	40x18	1,25	1159 105
150 – 200	40x18	1,5	1159 106
200 – 250	40x18	1,75	1159 107

$\mu\text{m}$ mm	$\varnothing$ mm	$\bar{m}$ kg	Nº
250 – 300	40x18	2,0	1159 108
300 – 350	40x18	2,2	1159 109
350 – 400	40x18	2,35	1159 110
400 – 450	40x18	2,6	1159 111
450 – 500	40x18	2,75	1159 112
500 – 550	40x18	3,0	1159 113
550 – 600	40x18	3,1	1159 114

$\mu\text{m}$ mm	$\varnothing$ mm	$\bar{m}$ kg	Nº
600 – 650	40x18	3,3	1159 115
650 – 700	40x18	3,7	1159 116
700 – 750	40x18	3,9	1159 117
750 – 800	40x18	4,1	1159 118
800 – 850	40x18	4,3	1159 119
Feinzeiger 0,001mm Comparator gauges 0.001mm			1308 501

## Anzeigende Rachenlehren CARBON

## Indicating dial snap gauges CARBON



**CARBON**

- ▶ Werksnorm
- ▶ Messeinsätze auswechselbar  $\varnothing 3,5\text{mm}$
- ▶ Bügel aus Kohlefaser
- ▶ extrem geringes Gewicht, hohe Formstabilität
- ▶ Zentrierstütze und Abhebevorrichtung
- ▶ Freihub 5mm
- ▶ konstante Messkraft
- ▶ Wiederholgenauigkeit mit Kugeleinsatz  $\pm 0,001\text{mm}$
- ▶ Messuhraufnahme  $\varnothing 8\text{mm}$
- ▶ Lieferung im Etui ohne Messuhr mit Kugelmesseinsätze  $\varnothing 3\text{mm}$

- ▶ Works standard
- ▶ Interchangeable measuring inserts
- ▶ Carbon fibre frame
- ▶ Extremely low weight, high strength of shape
- ▶ Centre supports and lifting device
- ▶ Free lift 5mm
- ▶ Constant measuring force
- ▶ Repeatability with ball inserts  $\pm 0.001\text{mm}$
- ▶ Dial mounting hole  $\varnothing 8\text{mm}$
- ▶ Delivered in a case without dial gauge with ball inserts  $\varnothing 3\text{mm}$

### Anwendungen:

- ▶ Prüfen von Außendurchmessern, mit Sondermess-einsätzen auch in Nuten und Einstichen
- ▶ Gewindemessung mit Gewindeflankeneinsätzen Schaft  $\varnothing 3,5\text{mm}$  Nr. 2048 5..
- ▶ Verzahnungsmessung mit Messkugeln im Halter Nr. 2050 3.. und Adapterbolzen Nr. 1390 311

### Application:

- ▶ Measuring of outer diameters, with special measuring inserts also in slots and recesses
- ▶ Thread measurements with thread inserts shaft  $\varnothing 3.5\text{mm}$  No. 2048 5..
- ▶ Gear tooth measurements with measuring balls in holder No. 2050 3.. and adaptor bolts No. 1390 311

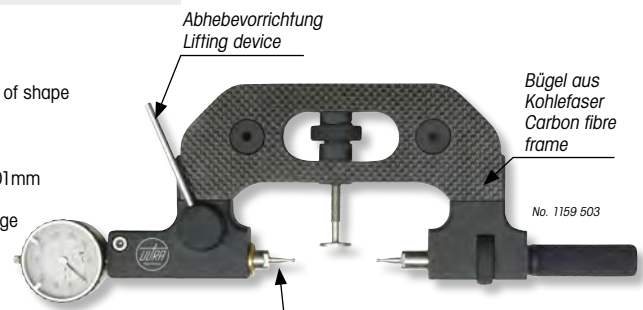

No. 1159 503

Messeinsätze auswechselbar  $\varnothing 3,5$   
Measuring inserts interchangeable  $\varnothing 3.5$

**!** Kleinmessuhr oder Feinzeiger mit kurzem Schaft verwenden!  
Nr. 1308 201 / Nr. 1308 202

**!** Small dial gauge or comparator gauge with short shaft!  
No. 1308 201 / No. 1308 202

A $\mu\text{m}$ mm	B mm	C mm	$\bar{m}$ kg	Nº
0 – 50	247	95	0,42	1159 501
50 – 100	297	124	0,5	1159 502
100 – 150	347	150	0,62	1159 503
150 – 200	397	174	0,72	1159 504
200 – 250	447	210	0,92	1159 505
250 – 300	497	234	1,02	1159 506
300 – 350	547	260	1,12	1159 507
350 – 400	597	284	1,22	1159 508
400 – 450	647	310	1,32	1159 509
450 – 500	707	374	1,42	1159 509x
500 – 600	960	437	2,1	1159 510
600 – 700	1010	487	2,4	1159 511
700 – 800	1060	537	2,7	1159 512
Adapterbolzen (Paar) / Adaptor bolts (pair)				1390 311

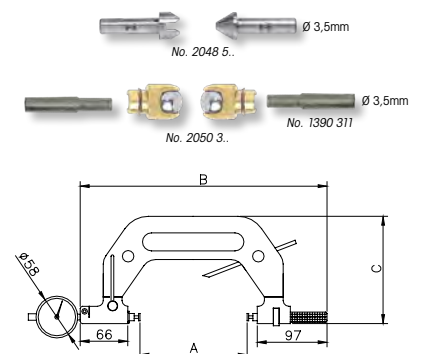

No. 2048 5..

$\varnothing 3,5\text{mm}$

No. 2050 3..

$\varnothing 3,5\text{mm}$

**Halter für Rachenlehren CARBON**

**Holder for snap gauges CARBON**



No. 1159 521

- ▶ Klemmeinrichtung schwenkbar
- ▶ rostfreier Stahl
- ▶ Lieferung einzeln verpackt

- ▶ Pivoting clamping device
- ▶ stainless steel
- ▶ Delivered in individual packages



<b>m</b> kg	<b>Nº</b>
3,0	1159 521

**Messeinsätze, Paar für Rachenlehren CARBON**

**Measuring inserts, pair for snap gauges CARBON**



**Gehärtet  
Hardened**

- ▶ Spezialstahl gehärtet
- ▶ Passend für alle ULTRA Vergleichsmessgröße, Rachenlehren, QUICK CHECK etc. mit Einspannschaft  $\varnothing$  3,5mm
- ▶ Lieferung als Paar einzeln verpackt

- ▶ Special steel hardened
- ▶ Usable for all ULTRA comparative measuring instruments, snap gauges, QUICK CHECK etc. with shaft  $\varnothing$  3.5mm
- ▶ Delivered as pair in individual packages

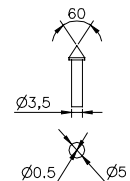
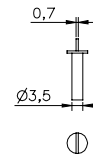
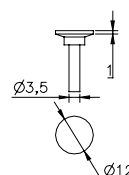
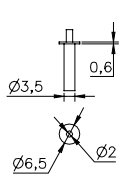
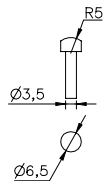
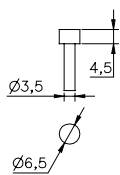

<b>Nº</b>	<b>1159 901</b>	<b>1159 902</b>	<b>1159 903</b>	<b>1159 904</b>	<b>1159 905</b>	<b>1159 906</b>
-----------	-----------------	-----------------	-----------------	-----------------	-----------------	-----------------

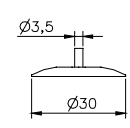
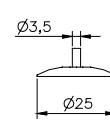
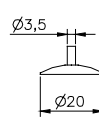
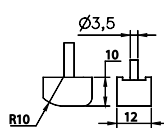
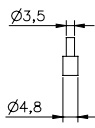
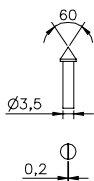

<b>Nº</b>	<b>1159 907</b>	<b>1159 908</b>	<b>1159 909</b>	<b>1159 910</b>	<b>1159 911</b>	<b>1159 912</b>
-----------	-----------------	-----------------	-----------------	-----------------	-----------------	-----------------

**Gewindeflankeneinsätze 60°, Paar für Rachenlehren CARBON**

**Thread inserts 60°, pair for snap gauges CARBON**



**Gehärtet  
Hardened**

- ▶ Spezialstahl gehärtet
- ▶ Passend für alle ULTRA Vergleichsmessgröße, Rachenlehren, QUICK CHECK etc. mit Einspannschaft  $\varnothing$  3,5mm
- ▶ Lieferung als Paar einzeln verpackt

- ▶ Special steel hardened
- ▶ Usable for all ULTRA comparative measuring instruments, snap gauges, QUICK CHECK etc. with shaft  $\varnothing$  3.5mm
- ▶ Delivered as pair in individual packages

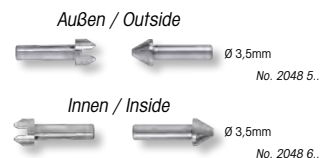

Steigung M	Pitch UNF	Außen / Outside Nº	Innen / Inside Nº	Steigung M	Pitch UNF	Außen / Outside Nº	Innen / Inside Nº
0,4 - 0,5	64 - 48	2048 501	2048 601	2 - 3	13 - 9	2048 504	2048 604
0,6 - 0,9	44 - 28	2048 502	2048 602	3,5 - 5,0	8 - 5	2048 505	2048 605
1,0 - 1,75	24 - 14	2048 503	2048 603	5,5 - 7,0	4,5 - 3,5	2048 506	2048 606



Wir liefern jede Art von Sonderlehren und Vorrichtungen nach Ihren Zeichnungen – auf Wunsch auch Konzeption und Konstruktion, gegen Berechnung.

Zur Angebotserstellung bitten wir um Ihre Anfragen mit Zeichnungsunterlagen.

**Beispiele für bereits realisierte kundenspezifische Sonderlösungen:**

We supply all types of special gauges and devices according to your drawings – on request also undertake conception and design at a cost.

For the preparation of a quotation, please send your inquiries with drawings.

**Examples of already executed customer-specific special solutions:**



*Einstellmeister PKW Kurbelgehäuse  
4 Zylinder für die Automobilindustrie.*

*Setting master car crankshaft  
4 cylinder for the automotive industry*



*Vorrichtung zur Durchmesserkontrolle  
von Kolben für die Automobilindustrie.*

*Device for checking diameter of pistons  
for the automotive industry*



*Vorrichtung zur Maßkontrolle von Lenkrädern  
für die Automobilindustrie.*

*Device for checking dimensions of the steering  
wheels for the automotive industry.*



*Vorrichtung zur Längenprüfung  
von Turboladerwellen.*

*Device for checking lengths  
of turbochargers shafts.*

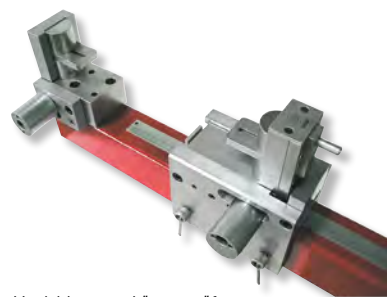

*Vorrichtung zur Längenprüfung  
von Gerüstbauteilen.*

*Device for checking lengths of  
scaffolding parts.*

# 3

## Gewindelehren

Thread gauges

## Nutenlehren

Shaft keyway gauges

## Vierkant- Sechskantlehren

Square, hexagonal gauges

## Verzahnungslehren

Serration gauges

## Verzahnungsmessgeräte

Serration measuring instruments



Grenz-Gewindelehndorne aus Keramik  
Limit thread plug gauges, ceramic



3.8

Leitech Gewindeprüfdorne  
Leitech thread plug gauge

**leitech**  
INSTRUMENTS



3.9

Messgeräte für Verzahnungsmessung  
Measuring instrument for gear measurement



3.13

Vergleichsmessgerät QUICK CHECK  
Comparative measuring bench QUICK CHECK



3.15

## Gewindelehren

Die im Katalog geführten Gewindearten und Größen sind ein kleiner Auszug aus unserem umfassenden Lieferprogramm für Gewindelehren. Andere Abmessungen und Gewindesteigungen finden Sie in unserer Preisliste für Gewindelehren. Grenzgewindelehrendorne bis Ø 40mm werden in der Regel mit Gutseite und Ausschussseite in einem Griff geliefert. Darüber erfolgt die Lieferung mit je einem Griff für Gutseite und Ausschussseite. Lehregriffe werden aus Stahl oder Aluminium geliefert.

Unsere Listenpreise beziehen sich immer auf Arbeitslehren gemäß folgenden Toleranzfeldern:

Gewindeart Thread type	Toleranzfeld / Tolerance field		
	Lehrdorne Plug gauges	Lehrringe Ring gauges	Rachen- und Einstelllehren Thread snap and setting gauges
Metrisches ISO Gewinde DIN 13 < M 1,6 ISO metric threads DIN 13 < M 1.6	5H	6h	6h
Metrisches ISO Gewinde DIN 13 ≥ M 1,6 ISO metric threads DIN 13 ≥ M 1.6	6H	6g	6g
Whitworth Regelgewinde BS 84 Whitworth standard thread BS 84	medium class	medium class	medium class
Whitworth Feingewinde BS 84 Whitworth fine thread BS 84	medium class	medium class	medium class
Whitworth Rohrgewinde DIN ISO 228 Whitworth pipe thread DIN ISO 228	Mittel / Medium	A	A
Trapezgewinde DIN 103 Trapezoidal screw thread DIN 103	7H	7e	7e
Rundgewinde DIN 405 Knuckle thread DIN 405	7H	7h	-
UNC / UNF / UNEF Gewinde ANSI (BS 919) UNC / UNF / UNEF thread ANSI (BS 919)	2B	2A	2A

- TIN und TiCN beschichtete oder hartverchromte Gewindelehren
- Einzelne Gut- oder Ausschussgewindelehrendorne sowie Gewinderollenrachenlehren und Einstelllehren
- Messzapfen mit Schmutznute
- Minimum-, Maximum- und Abnutzungsprüfdorne
- Mehrgängige Gewinde und Sondergewinde nach Zeichnung

Die in den Lehren-Normen angegebenen Flankendurchmesser und Toleranzen für neue feste Gewindelehrringe gelten nicht, wenn die Gewindelehrringe wie üblich nach Prüfdornen gefertigt werden. Sollen jedoch die Ringe im Flankendurchmesser direkt gemessen werden, gelten die in den Normen festgelegten Sollmaße und Toleranzen. Für diesen Fall muss dies bei der Bestellung von Gewindelehrringen ausdrücklich angegeben werden. Eine spätere Beanstandung oder Reklamation wird nicht akzeptiert.

### Kalibrierung:

Gewindelehren können mit einem Werkskalibrierschein oder DAkkS-Kalibrierschein eines akkreditierten Labors geliefert werden.

Bitte beachten Sie hierzu unsere Nettopreisliste für die Erstellung von Prüfberichten.

Weiter Informationen erhalten Sie unter:

[www.ultra-germany.com](http://www.ultra-germany.com) > Produkte > Service > Prüfmittelüberwachung

### Kundenschnellservice:

Mit diesem Service ermöglichen wir für Lehren extrem kurze Lieferzeiten gegenüber der üblichen Standard-Lieferzeit. Die Fertigung erfolgt in der Regel in Überstunden. Für diese besondere Leistung werden entsprechende Zuschläge zu den Grundpreisen berechnet.

Die Möglichkeit für einen Schnellservice muss im Einzelfall für jede gewünschte Lehre geprüft werden.

Bitte vermerken Sie hierzu in Ihrer Anfrage „Lieferung im Kundenschnellservice“ und Ihren Wunschtermin.

## Thread gauges

The thread gauge types and sizes listed in the catalogue are a brief summary of our comprehensive thread gauge product range. Other dimensions and thread pitches can be found in our thread gauge price list. Limit thread plug gauge up to Ø 40 mm are usually supplied with GO and NO-GO sides in one handle; one handle each for GO and NO-GO side is supplied for larger diameters.

Gauge handles will be delivered from steel or aluminium.

Our listed prices always refer to the workshop gauges in accordance with the following tolerance fields:

- TIN- and TiCN-coated or hard chrome-plated thread gauges
- Individual GO or NO-GO plug thread gauges, thread snap gauges with rollers and thread setting gauges
- Gauge member with dust groove
- Minimum, maximum and wear test plug gauges
- Multistart and special threads according to drawings

The pitch diameter and tolerances given in the gauge standards are not applicable for newly fixed thread ring gauges, if these ring gauges are, as is customary, manufactured according to test plug gauges. In case the rings are directly measured in the pitch diameter, the specified sizes and tolerances given in the standards are applicable. In such a case, this must be explicitly stated in the order for thread ring gauges. A subsequent complaint or claim will not be accepted.

### Calibration:

Thread gauges can be supplied with a works calibration certificate or DAkkS calibration certificate of an accredited laboratory.

Please take note of our net price list for the preparation of calibration reports.

Further information can be had at:

[www.ultra-germany.com](http://www.ultra-germany.com) > Products > Service > Calibration

### Customer express service:

We offer extremely short delivery times with this service compared to the usual standard delivery time. In general, the production is manufactured in overtime. An appropriate extra fee is added to the basic price for this special service.

The possibility for an express service must be checked in individual cases especially for each desired gauge.

Please mark your enquiry with "To be delivered in Customer Express Service" and mention your desired date.



**Gewindelehren**  
metrische ISO-Regelgewinde ISO 1502 (DIN 13)

**Thread gauges**  
ISO metric threads ISO 1502 (DIN 13)

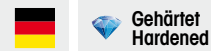

- ▶ Lehnstahl gehärtet
- ▶ Ausschussseite rot gekennzeichnet
- ▶ Lieferung einzeln verpackt

- ▶ Hardened tool steel
- ▶ Red-marked NO-GO side
- ▶ Delivered in individual packages



No. 1200 1..



No. 1204 1..



No. 1205 1..

**1200 1.. :**  
Grenz-Gewindelehndorne 6H (<M1,6 – 5H)  
(Gut- und Ausschussseite)

**1200 1.. :**  
Limit thread plug gauge 6H (<M1.6 – 5H)  
(GO and NO-GO side)

**1204 1.. :**  
Gut-Gewindelehringe 6g (<M1,6 – 6h)

**1204 1.. :**  
GO thread ring gauge 6g (<M1.6 – 6h)

**1205 1.. :**  
Ausschuss-Gewindelehringe 6g (<M1,6 – 6h)

**1205 1.. :**  
NO-GO thread ring gauge 6g (<M1.6 – 6h)

! Linksgewinde sowie andere Toleranzen werden mit Zuschlägen berechnet.

! Left hand thread and other tolerances have extra charges.

! TIN und TiCN beschichtete oder hartverchromte Gewindelehren auf Anfrage.

! TIN- and TiCN-coated or hard chrome-plated thread gauges on request.

Größe Size	Nº	Nº	Nº	Größe Size	Nº	Nº	Nº	Größe Size	Nº	Nº	Nº
M 1x0,25	1200 101	1204 101	1205 101	M 4x0,7	1200 111	1204 111	1205 111	M 16x2	1200 121	1204 121	1205 121
M 1,1x0,25	1200 101x	1204 101x	1205 101x	M 4,5x0,75	1200 112	1204 112	1205 112	M 18x2,5	1200 122	1204 122	1205 122
M 1,2x0,25	1200 102	1204 102	1205 102	M 5x0,8	1200 113	1204 113	1205 113	M 20x2,5	1200 123	1204 123	1205 123
M 1,4x0,3	1200 103	1204 103	1205 103	M 6x1	1200 114	1204 114	1205 114	M 22x2,5	1200 124	1204 124	1205 124
M 1,6x0,35	1200 104	1204 104	1205 104	M 7x1	1200 114x	1204 114x	1205 114x	M 24x3	1200 125	1204 125	1205 125
M 1,8x0,35	1200 105	1204 105	1205 105	M 8x1,25	1200 115	1204 115	1205 115	M 27x3	1200 126	1204 126	1205 126
M 2x0,4	1200 106	1204 106	1205 106	M 9x1,25	1200 116	1204 116	1205 116	M 30x3,5	1200 127	1204 127	1205 127
M 2,2x0,45	1200 107	1204 107	1205 107	M 10x1,5	1200 117	1204 117	1205 117	M 33x3,5	1200 128	1204 128	1205 128
M 2,5x0,45	1200 108	1204 108	1205 108	M 11x1,5	1200 118	1204 118	1205 118	M 36x4	1200 129	1204 129	1205 129
M 3x0,5	1200 109	1204 109	1205 109	M 12x1,75	1200 119	1204 119	1205 119	M 39x4	1200 130	1204 130	1205 130
M 3,5x0,6	1200 110	1204 110	1205 110	M 14x2	1200 120	1204 120	1205 120	M 42x4,5	1200 131	1204 131	1205 131

Andere Größen – siehe Gewindelehrenpreisliste. / See thread gauge price list for other sizes.

**Gewindelehrensätze**  
metrische ISO-Regelgewinde ISO 1502 (DIN 13)

**Thread gauge sets**  
ISO metric threads ISO 1502 (DIN 13)



- ▶ Lehnstahl gehärtet
- ▶ Ausschussseite rot gekennzeichnet
- ▶ Lieferung im Holzetui

- ▶ Hardened tool steel
- ▶ Red-marked NO-GO side
- ▶ Delivered in wooden box



No. 1200 201

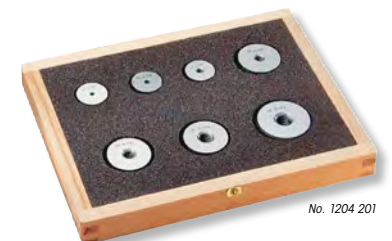

No. 1204 201

**1200 201 :**  
Satz Grenz-Gewindelehndorne 6H  
(Gut- und Ausschussseite)

**1200 201 :**  
Limit thread plug gauge 6H set  
(GO and NO-GO side)

**1204 201 :**  
Satz Gut-Gewindelehringe 6g

**1204 201 :**  
GO thread ring gauge 6g set

**1205 201 :**  
Satz Ausschuss-Gewindelehring 6g

**1205 201 :**  
NO-GO thread ring gauge 6g set

Stück Pieces	Größe Size	kg	Nº	Nº	Nº
7	M3 / M4 / M5 / M6 / M8 / M10 / M12	0,6	1200 201	1204 201	1205 201

**Gewindelehren aus Hartmetall**  
metrische ISO-Regelgewinde ISO 1502 (DIN 13)

**Thread gauges, tungsten carbide**  
ISO metric threads ISO 1502 (DIN 13)



- ▶ Ausschussseite rot gekennzeichnet
- ▶ Lieferung einzeln verpackt

- ▶ Red-marked NO-GO side
- ▶ Delivered in individual packages

**1200 5.. :**  
Grenz-Gewindelehndorne 6H,  
(Gutseite Hartmetall, Ausschussseite Lehnstahl)

**1200 5.. :**  
Limit thread plug gauge 6H  
(GO side of tungsten carbide, NO-GO side of tool steel)

**1200 6.. :**  
Grenz-Gewindelehndorne 6H  
(Gut- und Ausschussseite Hartmetall)

**1200 6.. :**  
Limit thread plug gauge 6H  
(GO and NO-GO side of tungsten carbide)

**1204 5.. :**  
Gut-Gewindelehrringe 6g  
(Hartmetall)

**1204 5.. :**  
GO thread ring gauge 6g  
(Tungsten carbide)

**1205 5.. :**  
Ausschuss-Gewindelehrringe 6g  
(Hartmetall)

**1205 5.. :**  
NO-GO thread ring gauge 6g  
(Tungsten carbide)

**!** Linksgewinde sowie andere Toleranzen werden mit Zuschlägen berechnet.

**!** Left hand thread and other tolerances have extra charges.



No. 1200 5..



No. 1204 5..



No. 1205 5..

Größe Size	Nº	Nº	Nº	Nº	Größe Size	Nº	Nº	Nº	Nº
M 1,6x0,35	1200 504	1200 604	-	-	M 9x1,25	1200 516	1200 616	1204 516	1205 516
M 1,8x0,35	1200 505	1200 605	-	-	M 10x1,5	1200 517	1200 617	1204 517	1205 517
M 2x0,4	1200 506	1200 606	-	-	M 11x1,5	1200 518	1200 618	1204 518	1205 518
M 2,2x0,45	1200 507	1200 607	-	-	M 12x1,75	1200 519	1200 619	1204 519	1205 519
M 2,5x0,45	1200 508	1200 608	-	-	M 14x2	1200 520	1200 620	1204 520	1205 520
M 3x0,5	1200 509	1200 609	-	-	M 16x2	1200 521	1200 621	1204 521	1205 521
M 3,5x0,6	1200 510	1200 610	-	-	M 18x2,5	1200 522	1200 622	1204 522	1205 522
M 4x0,7	1200 511	1200 611	-	-	M 20x2,5	1200 523	1200 623	1204 523	1205 523
M 5x0,8	1200 513	1200 613	-	-	M 22x2,5	1200 524	1200 624	1204 524	1205 524
M 6x1	1200 514	1200 614	-	-	M 24x3	1200 525	1200 625	1204 525	1205 525
M 7x1	1200 514x	1200 614x	-	-	M 27x3	1200 526	1200 626	1204 526	1205 526
M 8x1,25	1200 515	1200 615	1204 515	1205 515	M 30x3,5	1200 527	1200 627	1204 527	1205 527

Andere Größen auf Anfrage. / Other sizes on request.

**Gewindelehren Amerikanisches Rohrgewinde**  
NPT nach ANSI/ASME B.1.20.1

**Thread gauges, American pipe threads**  
NPT according to ANSI/ASME B.1.20.1



- ▶ Lehnstahl gehärtet
- ▶ Lieferung einzeln verpackt

- ▶ Hardened tool steel
- ▶ Delivered in individual packages

**1291 1.. :**  
Grenz-Gewindelehndorne  
mit Toleranzstufe

**1291 1.. :**  
Limit thread plug gauge  
with tolerance step

**1294 1.. :**  
Grenz-Gewindelehrringe  
mit Toleranzstufe

**1294 1.. :**  
Limit thread ring gauge  
with tolerance step

**!** NPTF, 3 oder 4-stufige Ausführung nach ANSI B1.20.5 auf Anfrage.

**!** NPTF, 3 or 4 stepped versions according to ANSI B1.20.5 on request.



No. 1291 1..

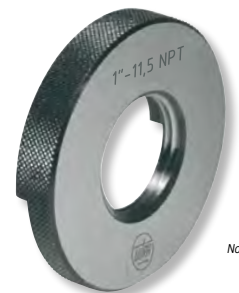

No. 1294 1..

Größe Size	Nº	Nº	Größe Size	Nº	Nº
1/16"-27 NPT	1291 101	1294 101	1 1/4"-11,5 NPT	1291 108	1294 108
1/8"-27 NPT	1291 102	1294 102	1 1/2"-11,5 NPT	1291 109	1294 109
1/4"-18 NPT	1291 103	1294 103	2"-11,5 NPT	1291 110	1294 110
3/8"-18 NPT	1291 104	1294 104	2 1/2"-8 NPT	1291 111	1294 111
1/2"-14 NPT	1291 105	1294 105	3"-8 NPT	1291 112	1294 112
3/4"-14 NPT	1291 106	1294 106	3 1/2"-8 NPT	1291 113	1294 113
1"-11,5 NPT	1291 107	1294 107	4"-8 NPT	1291 114	1294 114

Andere Größen – siehe Gewindelehrenpreisliste. / See thread gauge price list for other sizes.

**Gewindelehren**  
metrische ISO-Feingewinde ISO 1502 (DIN 13)

**Thread gauges**  
ISO metric fine threads ISO 1502 (DIN 13)

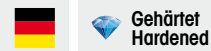

- ▶ Lehrenstahl gehärtet
- ▶ Ausschussseite rot gekennzeichnet
- ▶ Lieferung einzeln verpackt

- ▶ Hardened tool steel
- ▶ Red-marked NO-GO side
- ▶ Delivered in individual packages

**1210 ... :**  
Grenz-Gewindelehndorne 6H  
(Gut - und Ausschussseite)

**1210 ... :**  
Limit thread plug gauge 6H  
(GO and NO-GO side)

**1214 ... :**  
Gut-Gewindelehringe 6g

**1214 ... :**  
GO thread ring gauge 6g

**1215 ... :**  
Ausschuss-Gewindelehringe 6g

**1215 ... :**  
NO-GO thread ring gauge 6g

! Linksgewinde sowie andere Toleranzen werden mit Zuschlägen berechnet.

! Left hand thread and other tolerances have extra charges.

! TIN und TiCN beschichtete oder hartverchromte Gewindelehren auf Anfrage.

! TIN- and TiCN-coated or hard chrome-plated thread gauges on request.



No. 1210.1.



No. 1214.1.



No. 1215.1.

Größe Size	Nº	Nº	Nº
M 8x0,5	1210 122	1214 122	1215 122
M 10x0,5	1210 123	1214 123	1215 123
M 8x0,75	1210 130	1214 130	1215 130
M 10x0,75	1210 132	1214 132	1215 132
M 8x1	1210 153	1214 153	1215 153
M 10x1	1210 155	1214 155	1215 155
M 11x1	1210 156	1214 156	1215 156
M 12x1	1210 157	1214 157	1215 157
M 14x1	1210 159	1214 159	1215 159
M 16x1	1210 161	1214 161	1215 161
M 18x1	1210 163	1214 163	1215 163
M 20x1	1210 165	1214 165	1215 165
M 24x1	1210 169	1214 169	1215 169
M 30x1	1210 174	1214 174	1215 174

Größe Size	Nº	Nº	Nº
M 10x1,25	1210 202	1214 202	1215 202
M 12x1,25	1210 203	1214 203	1215 203
M 14x1,25	1210 204	1214 204	1215 204
M 12x1,5	1210 205	1214 205	1215 205
M 14x1,5	1210 207	1214 207	1215 207
M 16x1,5	1210 209	1214 209	1215 209
M 18x1,5	1210 211	1214 211	1215 211
M 20x1,5	1210 212	1214 212	1215 212
M 22x1,5	1210 213	1214 213	1215 213
M 24x1,5	1210 214	1214 214	1215 214
M 25x1,5	1210 215	1214 215	1215 215
M 26x1,5	1210 216	1214 216	1215 216
M 27x1,5	1210 217	1214 217	1215 217
M 28x1,5	1210 218	1214 218	1215 218

Größe Size	Nº	Nº	Nº
M 30x1,5	1210 219	1214 219	1215 219
M 32x1,5	1210 220	1214 220	1215 220
M 33x1,5	1210 221	1214 221	1215 221
M 35x1,5	1210 223	1214 223	1215 223
M 36x1,5	1210 224	1214 224	1215 224
M 38x1,5	1210 225	1214 225	1215 225
M 40x1,5	1210 227	1214 227	1215 227
M 20x2	1210 315	1214 315	1215 315
M 24x2	1210 317	1214 317	1215 317
M 27x2	1210 320	1214 320	1215 320
M 30x2	1210 322	1214 322	1215 322
M 33x2	1210 324	1214 324	1215 324
M 36x2	1210 327	1214 327	1215 327
M 40x2	1210 330	1214 330	1215 330

Andere Größen – siehe Gewindelehenpreisliste. / See thread gauge price list for other sizes.

**Gewindelehren**  
kegeliges Whitworth Rohrgewinde

**Thread gauges**  
Whitworth pipe threads tapered

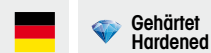

- ▶ DIN 2999 (August 1973)
- ▶ Lehrenstahl gehärtet
- ▶ Lieferung einzeln verpackt

- ▶ DIN 2999 (August 1973)
- ▶ Hardened tool steel
- ▶ Delivered in individual packages

**1291 3.. :**  
Grenz-Gewindelehndorne (kegelig) Rp  
mit Toleranzstufe

**1291 3.. :**  
Limit thread plug gauge (tapered) Rp  
with tolerance step

**1294 3.. :**  
Grenz-Gewindelehringe (zylindrisch) R  
mit Toleranzstufe

**1294 3.. :**  
Limit thread ring gauge (cylindrical) R  
with tolerance step

! Lehren nach ISO 7/2-2000 auf Anfrage.

! Gauges according to ISO 7/2-2000 on request.



No. 1291.3.

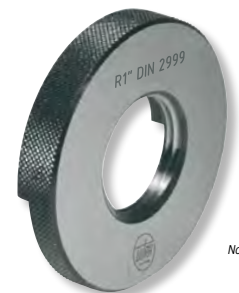

No. 1294.3.

Größe Size	Nº	Nº
Rp / R 1/16"	1291 301	1294 301
Rp / R 1/8"	1291 302	1294 302
Rp / R 1/4"	1291 303	1294 303
Rp / R 3/8"	1291 304	1294 304
Rp / R 1/2"	1291 305	1294 305
Rp / R 3/4"	1291 306	1294 306
Rp / R 1"	1291 307	1294 307

Größe Size	Nº	Nº
Rp / R 1 1/4"	1291 308	1294 308
Rp / R 1 1/2"	1291 309	1294 309
Rp / R 2"	1291 310	1294 310
Rp / R 2 1/2"	1291 311	1294 311
Rp / R 3"	1291 312	1294 312
Rp / R 4"	1291 313	1294 313
Rp / R 5"	1291 314	1294 314

## Gewindelehren Whitworth-Rohrgewinde DIN ISO 228

## Thread gauges Whitworth pipe thread DIN ISO 228

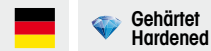

- ▶ Lehrenstahl gehärtet
- ▶ Ausschussseite rot gekennzeichnet
- ▶ Lieferung einzeln verpackt

- ▶ Hardened tool steel
- ▶ Red-marked NO-GO side
- ▶ Delivered in individual packages

**1230 1.. :**  
Grenz-Gewindelehndorne medium  
(Gut- und Ausschussseite)

**1230 1.. :**  
Limit thread plug gauge medium  
(GO and NO-GO side)

**1234 1.. :**  
Gut-Gewindelehrringe A

**1234 1.. :**  
GO thread ring gauge A

**1235 1.. :**  
Ausschuß-Gewindelehrringe A

**1235 1.. :**  
NO-GO thread ring gauge A

! G = BSP - wird auf Wunsch mit dieser Beschriftung geliefert.

! G = BSP - will be supplied with this marking on request.

! Linksgewinde sowie andere Toleranzen werden mit Zuschlägen berechnet.

! Left hand thread and other tolerances have extra charges.

! TIN und TiCN beschichtete oder hartverchromte Gewindelehren auf Anfrage.

! TIN- and TiCN-coated or hard chrome-plated thread gauges on request.

Größe Size	Nº	Nº	Nº
G 1/8"	1230 102	1234 102	1235 102
G 1/4"	1230 103	1234 103	1235 103
G 3/8"	1230 104	1234 104	1235 104
G 1/2"	1230 105	1234 105	1235 105
G 5/8"	1230 106	1234 106	1235 106

Größe Size	Nº	Nº	Nº
G 3/4"	1230 107	1234 107	1235 107
G 7/8"	1230 108	1234 108	1235 108
G 1"	1230 109	1234 109	1235 109
G 1 1/8"	1230 110	1234 110	1235 110
G 1 1/4"	1230 111	1234 111	1235 111



No. 1230 1..



No. 1234 1..



No. 1235 1..

Andere Größen – siehe Gewindelehrenpreisliste. / See thread gauge price list for other sizes.

## Gewindelehren Amerikanische Einheitsgewinde UNC, UNF

## Thread gauges American unified threads UNC, UNF



- ▶ Lehrenstahl gehärtet
- ▶ Ausschussseite rot gekennzeichnet
- ▶ Lieferung einzeln verpackt

- ▶ Hardened tool steel
- ▶ Red-marked NO-GO side
- ▶ Delivered in individual packages

**1260 ... :**  
Grenz-Gewindelehndorne 2B / ANSI B1.1  
(Gut- und Ausschussseite)

**1260 ... :**  
Limit thread plug gauge 2B / ANSI B1.1  
(GO and NO-GO side)

**1264 ... :**  
Gut-Gewindelehrringe 2A / BS 919  
(ANSI B1.2 - auf Wunsch)

**1264 ... :**  
GO thread ring gauge 2A / BS 919  
(ANSI B1.2 - on request)

**1265 ... :**  
Ausschuß-Gewindelehrringe 2A / BS 919  
(ANSI B1.2 - auf Wunsch)

**1265 ... :**  
NO-GO thread ring gauge 2A / BS 919  
(ANSI B1.2 - on request)

! Linksgewinde sowie andere Toleranzen werden mit Zuschlägen berechnet.

! Left hand thread and other tolerances have extra charges.

! TIN und TiCN beschichtete oder hartverchromte Gewindelehren auf Anfrage.

! TIN- and TiCN-coated or hard chrome-plated thread gauges on request.

! Ringe nach UN, UNS und UNJ-Gewinde auf Anfrage.

! Rings according to UN, UNS and UNJ threads on request.

Größe Size	Nº	Nº	Nº
No 4-40 UNC	1260 104	1264 104	1265 104
No 5-40 UNC	1260 105	1264 105	1265 105
No 6-32 UNC	1260 106	1264 106	1265 106
No 8-32 UNC	1260 107	1264 107	1265 107
No 10-24 UNC	1260 108	1264 108	1265 108
No 12-24 UNC	1260 109	1264 109	1265 109
1/4"-20 UNC	1260 110	1264 110	1265 110
5/16"-18 UNC	1260 111	1264 111	1265 111
3/8"-16 UNC	1260 112	1264 112	1265 112
7/16"-14 UNC	1260 113	1264 113	1265 113
1/2"-13 UNC	1260 114	1264 114	1265 114

Größe Size	Nº	Nº	Nº
9/16"-12 UNC	1260 115	1264 115	1265 115
5/8"-11 UNC	1260 116	1264 116	1265 116
3/4"-10 UNC	1260 117	1264 117	1265 117
7/8"-9 UNC	1260 118	1264 118	1265 118
1"-8 UNC	1260 119	1264 119	1265 119
No 4-48 UNF	1260 205	1264 205	1265 205
No 5-44 UNF	1260 206	1264 206	1265 206
No 6-40 UNF	1260 207	1264 207	1265 207
No 8-36 UNF	1260 208	1264 208	1265 208
No 10-32 UNF	1260 209	1264 209	1265 209
No 12-28 UNF	1260 210	1264 210	1265 210



No. 1260 1..



No. 1264 1..



No. 1265 1..

Andere Größen – siehe Gewindelehrenpreisliste. / See thread gauge price list for other sizes.

**Gewindelehren**  
**Amerikanisches Extra-Feingewinde UNEF**

**Thread gauges**  
**American extra fine thread UNEF**

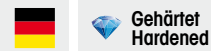

- ▶ Lehrenstahl gehärtet
- ▶ Ausschussseite rot gekennzeichnet
- ▶ Lieferung einzeln verpackt

- ▶ Hardened tool steel
- ▶ Red-marked NO-GO side
- ▶ Delivered in individual packages



No. 1260 I..

**1260 3.. :**  
Grenz-Gewindelehndorne 2B / ANSI B1.1  
(Gut- und Ausschussseite)

**1260 3.. :**  
Limit thread plug gauge 2B / ANSI B1.1  
(GO and NO-GO side)



No. 1264 I..

**1264 3.. :**  
Gut-Gewindelehringe 2A / BS 919  
(ANSI B1.2 - auf Wunsch)

**1264 3.. :**  
GO thread ring gauge 2A / BS 919  
(ANSI B1.2 - on request)

**1265 3.. :**  
Ausschuß-Gewindelehringe 2A / BS 919  
(ANSI B1.2 - auf Wunsch)

**1265 3.. :**  
NO-GO thread ring gauge 2A / BS 919  
(ANSI B1.2 - on request)

! Linksgewinde sowie andere Toleranzen werden mit Zuschlägen berechnet.

! Left hand thread and other tolerances have extra charges.

! TIN und TiCN beschichtete oder hartverchromte Gewindelehren auf Anfrage.

! TIN- and TiCN-coated or hard chrome-plated thread gauges on request.

! Andere Größen, Ringe nach ANSI B 1.2., UN, UNS und UNJ-Gewinde auf Anfrage.

! Other sizes and rings according to ANSI B 1.2., UN, UNS and UNJ threads on request.

Größe Size	Nº	Nº	Nº
No 12-32 UNEF	1260 301	1264 301	1265 301
1/4"-32 UNEF	1260 302	1264 302	1265 302
5/16"-32 UNEF	1260 303	1264 303	1265 303
3/8"-32 UNEF	1260 304	1264 304	1265 304
7/16"-28 UNEF	1260 305	1264 305	1265 305
1/2"-28 UNEF	1260 306	1264 306	1265 306
9/16"-24 UNEF	1260 307	1264 307	1265 307
5/8"-24 UNEF	1260 308	1264 308	1265 308

Größe Size	Nº	Nº	Nº
11/16"-24 UNEF	1260 309	1264 309	1265 309
3/4"-20 UNEF	1260 310	1264 310	1265 310
13/16"-20 UNEF	1260 311	1264 311	1265 311
7/8"-20 UNEF	1260 312	1264 312	1265 312
15/16"-20 UNEF	1260 313	1264 313	1265 313
1"-20 UNEF	1260 314	1264 314	1265 314
1 1/16"-18 UNEF	1260 315	1264 315	1265 315
1 1/8"-18 UNEF	1260 316	1264 316	1265 316

Größe Size	Nº	Nº	Nº
1 3/16"-18 UNEF	1260 317	1264 317	1265 317
1 1/4"-18 UNEF	1260 318	1264 318	1265 318
1 5/16"-18 UNEF	1260 319	1264 319	1265 319
1 3/8"-18 UNEF	1260 320	1264 320	1265 320
1 7/16"-18 UNEF	1260 321	1264 321	1265 321
1 1/2"-18 UNEF	1260 322	1264 322	1265 322
1 9/16"-18 UNEF	1260 323	1264 323	1265 323
1 5/8"-18 UNEF	1260 324	1264 324	1265 324

**Gewindelehren**  
**metrisches ISO Trapezgewinde DIN 103**

**Thread gauges**  
**metric ISO trapezoidal thread DIN 103**



- ▶ Lehrenstahl gehärtet
- ▶ Ausschussseite rot gekennzeichnet
- ▶ Lieferung einzeln verpackt

- ▶ Hardened tool steel
- ▶ Red-marked NO-GO side
- ▶ Delivered in individual packages



No. 1220 I..

**1220 1.. :**  
Grenz-Gewindelehndorne 7H  
(Gut- und Ausschussseite)

**1220 1.. :**  
Limit thread plug gauge 7H  
(GO and NO-GO side)



No. 1224 I..

**1224 1.. :**  
Gut-Gewindelehringe 7e

**1224 1.. :**  
GO thread ring gauge 7e

**1225 1.. :**  
Ausschuß-Gewindelehringe 7e

**1225 1.. :**  
NO-GO thread ring gauge 7e

! Linksgewinde sowie andere Toleranzen werden mit Zuschlägen berechnet.

! Left hand thread and other tolerances have extra charges.

! TIN und TiCN beschichtete oder hartverchromte Gewindelehren auf Anfrage.

! TIN- and TiCN-coated or hard chrome-plated thread gauges on request.

Größe Size	Nº	Nº	Nº
Tr 8x1,5	1220 101	1224 101	1225 101
Tr 9x2	1220 102	1224 102	1225 102
Tr 10x2	1220 103	1224 103	1225 103
Tr 11x2	1220 104	1224 104	1225 104
Tr 12x3	1220 105	1224 105	1225 105
Tr 14x3	1220 106	1224 106	1225 106
Tr 16x4	1220 107	1224 107	1225 107
Tr 18x4	1220 108	1224 108	1225 108

Größe Size	Nº	Nº	Nº
Tr 20x4	1220 109	1224 109	1225 109
Tr 22x5	1220 110	1224 110	1225 110
Tr 24x5	1220 111	1224 111	1225 111
Tr 26x5	1220 112	1224 112	1225 112
Tr 28x5	1220 113	1224 113	1225 113
Tr 30x6	1220 114	1224 114	1225 114
Tr 32x6	1220 115	1224 115	1225 115
Tr 34x6	1220 116	1224 116	1225 116

Größe Size	Nº	Nº	Nº
Tr 36x6	1220 117	1224 117	1225 117
Tr 38x7	1220 118	1224 118	1225 118
Tr 40x7	1220 119	1224 119	1225 119
Tr 42x7	1220 120	1224 120	1225 120
Tr 44x7	1220 121	1224 121	1225 121
Tr 46x8	1220 122	1224 122	1225 122
Tr 48x8	1220 123	1224 123	1225 123
Tr 50x8	1220 124	1224 124	1225 124

Andere Größen – siehe Gewindelehrenpreisliste. / See thread gauge price list for other sizes.

## Grenz-Gewindelehndorne aus Keramik

## Limit thread plug gauges, ceramic



TOP



Keramik  
Ceramic

- ▶ Werksnorm
- ▶ Gutseite Keramik, Ausschusseite Lehenstahl
- ▶ Gutseite extrem hart und korrosionsbeständig absolut verschleißfest
- ▶ Lieferung einzeln verpackt

- ▶ Works standard
- ▶ GO side of ceramic, NO-GO side of tool steel
- ▶ GO side extremely hard, anti-corrosive and absolutely wear-resistant
- ▶ Delivered in individual packages

**I** M 1,4 – M 12 auf Anfrage.  
Zur Angebotsstellung benötigen wir das Nennmaß, Gewindesteigung und die Toleranz.

**I** M 1.4 – M 12 on request.  
For the preparation of a quotation please specify the required nominal size, thread step and the tolerance.



Auf Anfrage / on request

## Schutzhülsen zur Aufbewahrung von Gewinde- und Rundpassungslehndornen

## Protection box for storage of thread- and cylindrical plug gauges



- ▶ aus Polypropylen (transparent)
- ▶ stufenlose Längenverstellung durch Rastermechanik
- ▶ feuchtigkeits- und ölresistent
- ▶ Vierkantende sichert gegen Wegrollen
- ▶ wiederverschließbar und mehrfach verwendbar

- ▶ Polypropylene (transparent)
- ▶ Telescopic length extension through ratchet mechanism
- ▶ Humidity and oil resistant
- ▶ Square end prevents rolling
- ▶ Re-usable

für / for Ø mm	Innen-Ø / Internal-Ø mm	l mm	Nº
≤ 3	7	0,50 – 0,90	TP 7 050
> 3 – 6	9	0,65 – 1,10	TP 9 065
> 6 – 10	12	0,80 – 1,20	TP 12 080
> 10 – 14	16	0,80 – 1,20	TP 16 080
> 14 – 16	18	0,80 – 1,20	TP 18 080
> 16 – 20	20	0,80 – 1,20	TP 20 080
> 20 – 26	26	1,20 – 2,00	TP 26 120
> 26 – 30	30	1,20 – 2,00	TP 30 120



## Schutzbox zur Aufbewahrung von Lehrringen

## Protection box for storage of ring gauges



- ▶ aus Polypropylen (transparent)
- ▶ mit sicherem Scharnierverschluss
- ▶ feuchtigkeits- und ölresistent
- ▶ wiederverschließbar und mehrfach verwendbar

- ▶ Polypropylene (transparent)
- ▶ With hinged lid
- ▶ Humidity and oil resistant
- ▶ Re-usable

für / for Ø mm	l mm	Nº
≤ 5	22x22x8	UB 22x8
> 5 – 9	35x35x12	UB 35x12
> 9 – 19	47x47x19	UB 47x19
> 19 – 31	67x67x26	UB 67x26



**Grenz-Gewinderollenrachenlehren** Limit thread snap gauges with rollers

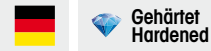

- ▶ Gewinderollen aus Lehrenstahl gehärtet
- ▶ Gut- und Ausschussgewinderollen in einem Rachen
- ▶ Verwendbar für Rechts- und Linksgewinde
- ▶ Einstellung erfolgt mit Grenz-Gewindeinstellehren
- ▶ Lieferung einzeln verpackt

- ▶ Thread rollers of hardened tool steel
- ▶ GO and NO-GO thread rollers in one gap
- ▶ Useable for right and left-hand thread
- ▶ Adjustment with a limit thread setting plug gauge
- ▶ Delivery in individual packages

! Alle Gewindearten und Größen sowie verstellbare und anzeigende Ausführungen auf Anfrage.

! All thread types and sizes as well as adjustable and indicating models on request.

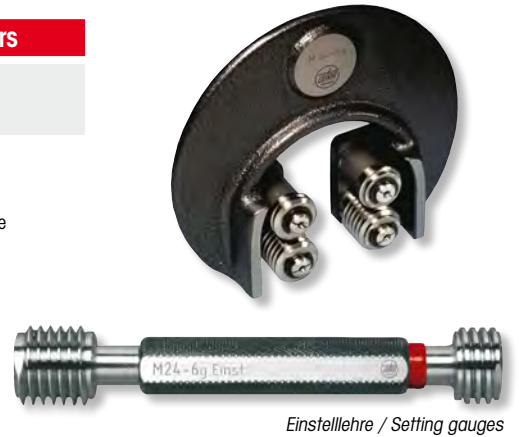

Einstelllehre / Setting gauges

**Leitech Gewindeprüfdrone mit Tiefenmessung** Leitech thread plug gauge with depth measurement



- ▶ Prüfung von Gewinde und Gewindetiefe in einem Arbeitsgang
- ▶ Gewindezapfen aus Lehrenstahl, gehärtet
- ▶ Gut- und Ausschussseite nach Verschleiß einzeln auswechselbar
- ▶ Toleranzen und Abmaße nach ISO 6H DIN 13
- ▶ Lieferung einzeln verpackt

- ▶ Testing of thread size and thread depth in one operation
- ▶ Threaded pin made of hardened tool steel
- ▶ Individually replaceable GO and NO-GO sides after wear out
- ▶ Tolerances and deviations according to ISO 6H DIN 13
- ▶ Delivered in individual packages

1208 1.. :  
Combi Ablesung 0,5mm an der Hülse

1208 1.. :  
Combi 0.5mm reading on the sleeve

1208 2.. :  
High-Res Ablesung 0,1mm am Nonius

1208 2.. :  
High-Res 0.1mm reading on the vernier

! Andere Größen und Gewindearten, Gewindeeinsätze aus Hartmetall, TiCN oder TiAN beschichtet sowie Kernlochlehndorne auf Anfrage.

! Other sizes and thread types, tungsten-carbide or TiCN- or TiAN-coated thread inserts and plain plug gauges on request.

Größe Size	LJ mm	Nº	Nº
M 2x0,4	10	1208 101	-
M 3x0,35	10	1208 102	-
M 3x0,5	10	1208 103	-
M 4x0,5	19	1208 103x	-
M 4x0,7	19	1208 104	1208 204
M 5x0,8	19	1208 105	1208 205
M 6x1	20	1208 106	1208 206
M 8x1,25	40	1208 107	1208 207
M 10x1	40	1208 108	1208 208
M 10x1,5	40	1208 109	1208 209
M 12x1	40	1208 110	1208 210
M 12x1,5	40	1208 111	1208 211

Größe Size	LJ mm	Nº	Nº
M 12x1,75	40	1208 112	1208 212
M 14x1	50	1208 113	-
M 14x1,5	50	1208 114	-
M 14x2	50	1208 115	-
M 16x1	50	1208 116	-
M 16x1,5	50	1208 117	-
M 16x2	50	1208 118	-
M 18x1	80	1208 119	-
M 18x2,5	80	1208 120	-
M 20x2,5	80	1208 121	-
M 22x2,5	80	1208 122	-

**leitech**  
INSTRUMENTS



No. 1208 1..  
Leitech Combi Prüfdrone  
Leitech Combi Gauge



No. 1208 2..  
Leitech High-Resolution Prüfdrone  
Leitech High-Resolution Gauge



Leitech Digi-Prüfdrone auf Anfrage  
Leitech Digi-Gauge on request



Leitech Digi-Speed Prüfdrone auf Anfrage  
Leitech Digi-Speed Gauge on request

**Leitech Einstellgerät** Leitech setting device



- ▶ zum Justieren des Tiefenmess-Systems nach dem Austausch der Gewindeeinsätze
- ▶ geeignet für alle metrischen Leitech Gewindeprüfdrone

- ▶ For adjusting the depth measurement system after replacement of the thread inserts
- ▶ Suitable for all Leitech thread plug gauges

! Leitech Abziehwerkzeug zum leichteren Austausch der Gewindeeinsätze auf Anfrage.

! Leitech levelling tool for facilitating the replacement of thread inserts on request.

Größe Size	Nº
M 2 – M 22	1208 301

**leitech**  
INSTRUMENTS



No. 1208 301

## Grenzwellennutenlehren Blockmaße

## Shaft keyway gauges Block gauges

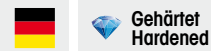

- ▶ Werksnorm
- ▶ Lehrenstahl gehärtet
- ▶ ISO Toleranzen P9, N9, JS9, JS10
- ▶ Lieferung einzeln verpackt

- ▶ Works standard
- ▶ Hardened steel
- ▶ ISO tolerances P9, N9, JS9 and JS10
- ▶ Delivered in individual packages

**1128 1.. :**  
Wellennutenlehren

**1128 1.. :**  
Shaft keyway gauges

**1128 2.. :**  
Nabennutenlehren, auf Anfrage

**1128 2.. :**  
Hub keyway gauges, on request

**1128 3.. :**  
Wellennutenlehren mit Schieber, auf Anfrage

**1128 3.. :**  
Shaft keyway gauges with slider, on request

**1128 4.. :**  
Nabennutenlehren mit Schieber, auf Anfrage

**1128 4.. :**  
Hub keyway gauges with slider, on request

**!** Zwischenmaße, zahlenmäßige Toleranzangaben, Qualität 6 und feiner auf Anfrage.

**!** Intermediate sizes, numerical tolerances, quality 6 and finer on request.

**!** Andere Nennmaße und Toleranzen, hartverchromte oder hartmetallbestückte Messflächen auf Anfrage.

**!** Other nominal sizes and tolerances, hard chrome or tungsten carbide tipped measuring faces on request.

mm	Nº
3 / 4 / 5	1128 102
6 / 7 / 8	1128 103
9 / 10 / 11 / 12	1128 104
13 / 14 / 15 / 16	1128 105
17 / 18 / 19 / 20	1128 106
21 / 22 / 23 / 24 / 25	1128 107

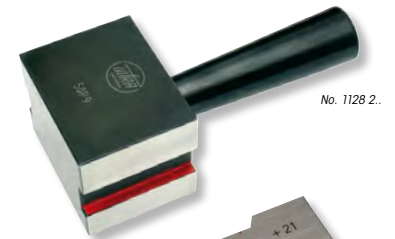

No. 1128 2..



No. 1128 1..



No. 1128 3..



No. 1128 4..

## Vierkant- und Sechskantlehren

## Square and hexagonal gauges

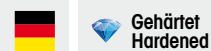

- ▶ Werksnorm
- ▶ Lehrenstahl gehärtet
- ▶ Lieferung einzeln verpackt

- ▶ Works standard
- ▶ Hardened steel
- ▶ Delivered in individual packages

**1090 1.. :**  
Vierkant-Grenzlehndorn, Ausschussseite vermindert

**1090 1.. :**  
Square limit plug gauges, NO-GO side reduced

**1090 2.. :**  
Vierkant-Grenzlehndorn, Ausschussseite voll

**1090 2.. :**  
Square limit plug gauges, NO-GO side full form

**1093 1.. :**  
Vierkant-Lehrring, Gut- oder Ausschuss

**1093 1.. :**  
Square ring gauges, GO or NO-GO

**1091 1.. :**  
Sechskant-Grenzlehndorn, Ausschussseite vermindert

**1091 1.. :**  
Hexagonal limit plug gauges, NO-GO side reduced

**1092 1.. :**  
Sechskant-Grenzlehndorn, Ausschussseite voll

**1092 1.. :**  
Hexagonal limit plug gauges, NO-GO side full form

**1094 1.. :**  
Sechskant-Lehrring, Gut- oder Ausschuss

**1094 1.. :**  
Hexagonal ring gauges, GO or NO-GO

**!** Alle Ausführungen auf Anfrage. Bitte Nennmaß und Toleranz angeben oder eine Zeichnung begeben.

**!** All executions on request. Please mention nominal size and tolerance or enclose your drawing.



No. 1090 1..

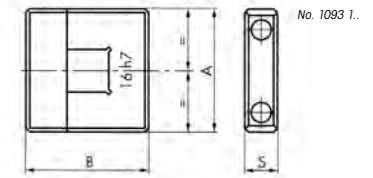

No. 1093 1..



No. 1091 1..

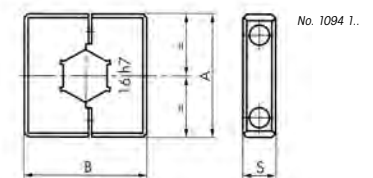

No. 1094 1..



**Digital-Messschieber, Nutsymmetriemessgerät für Nutmittenabstandsmessung**

**Digital calipers for slot center distance measuring**



- ▶ Werksnorm
- ▶ für Wellendurchmesser ≤120mm
- ▶ Feststellschraube
- ▶ rostfreier Stahl gehärtet
- ▶ großes LCD-Display
- ▶ 2 bewegliche Tastarme
- ▶ Lieferung im Etui

**Funktionen:**

- ▶ Ein/Aus
- ▶ mm/inch Umschaltung
- ▶ 0-Punkt an jeder Position
- ▶ ABS Funktion (fester 0-Punkt)

- ▶ Works standard
- ▶ for shaft diameter ≤120mm
- ▶ Locking screw
- ▶ Hardened stainless steel
- ▶ Large LCD display
- ▶ 2 moveable arms
- ▶ Delivered in individual packages

**Functions:**

- ▶ On/Off
- ▶ mm/inch commutation
- ▶ Zero setting at any position
- ▶ ABS function (fixed 0 point)



◀ links/left		◀ rechts/right		◀	kg	Nº
mm	inch	mm	inch	mm		
0 - 40	0 - 1,6	0 - 70	0 - 2.8	0,01	0,5	1850 651

**Digital Schnelltaster für Nutmittenabstandsmessung**

**Digital dial caliper gauges for slot center distance measuring**



- ▶ Werksnorm
- ▶ Schutzart IP 54, Sylvac System
- ▶ großes LCD-Display
- ▶ 1 fester Tastarm für auswechselbare Nutsteine, 1 beweglicher Tastarm
- ▶ Lieferung im Etui ohne Nutstein

**Funktionen:**

- ▶ Ein/Aus
- ▶ mm/inch Umschaltung
- ▶ 0-Punkt an jeder Position
- ▶ ± Preset Funktion
- ▶ Datenausgang Opto

- ▶ Works standard
- ▶ Protection class IP 54, Sylvac system
- ▶ Large LCD display
- ▶ 1 fixed arm for interchangeable sliding blocks and 1 movable arm
- ▶ Delivered in case without sliding blocks

**Functions:**

- ▶ On/Off
- ▶ mm/inch commutation
- ▶ Zero setting at any position
- ▶ ± Preset function
- ▶ Data output Opto



! Bei Bestellung von Nr. 1347 351 Nutbreite (4-20mm) angeben

! Specify slot width (4-20mm) in case of order no. 1347 351

mm	◀ mm	mm	N	A mm	B mm	kg	Nº	
8 - 58	0,01	0,02	5	29	4	0,4	1347 301	
50 - 100	0,01	0,02	5	50	25	0,4	1347 302	
1 Stück Nutstein 4-20mm / 1 pcs. Key slot 4-20mm								1347 351
Datenkabel RS232 (2m) / Data cable RS232 (2m)								1850 203
Datenkabel USB (2m) / Data cable USB (2m)								1850 204

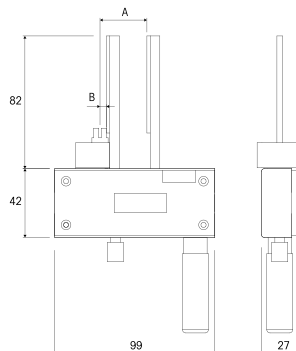

## Keilnaben- und Keilwellenlehren

## Straight sided spline gauges



- ▶ DIN 5462 / 5463 / 5464 / 5471 / 5472
- ▶ Lehrenstahl gehärtet
- ▶ Gutseite vollverzahnt
- ▶ Ausschussseite sektorverzahnt
- ▶ Lieferung einzeln verpackt

- ▶ DIN 5462 / 5463 / 5464 / 5471 / 5472
- ▶ hardened tool steel
- ▶ GO side full serrated
- ▶ NO-GO side sector serrated
- ▶ Delivered in individual packages

**1129 1..**  
Gutlehndorn für Keilnabenprofile, auf Anfrage

**1129 1..**  
GO plug gauge for straight sided splines, on request

**1129 2..**  
Ausschusslehndorn für Keilnabenprofile, auf Anfrage

**1129 2..**  
NO-GO plug gauge for straight sided splines, on request

**1129 3..**  
Gut-Lehrring für Keilwellenprofile, auf Anfrage

**1129 3..**  
GO ring gauge for straight sided splines, on request

**1129 4..**  
Ausschuss-Lehrring für Keilwellenprofile, auf Anfrage

**1129 4..**  
NO-GO ring gauge for straight sided splines, on request



## Kerbverzahnungslehren

## Serration spline gauges



- ▶ DIN 5481
- ▶ Lehrenstahl gehärtet
- ▶ Gutseite vollverzahnt
- ▶ Ausschussseite sektorverzahnt
- ▶ Lieferung einzeln verpackt

- ▶ DIN 5481
- ▶ hardened tool steel
- ▶ GO side full serrated
- ▶ NO-GO side sector serrated
- ▶ Delivered in individual packages

**1129 6..**  
Gut-Lehndorn für Kerbverzahnung, auf Anfrage

**1129 6..**  
GO plug gauge for serration splines, on request

**1129 7..**  
Ausschuss-Lehndorn für Kerbverzahnung, auf Anfrage

**1129 7..**  
NO-GO plug gauge for serration splines, on request

**1129 8..**  
Gut-Lehrring für Kerbverzahnung, auf Anfrage

**1129 8..**  
GO ring gauge for serration splines, on request

**1129 9..**  
Ausschuss-Lehrring für Kerbverzahnung, auf Anfrage

**1129 9..**  
NO-GO ring gauge for serration splines, on request

**!** Lehren für Evolventverzahnung, Meisterräder sowie Spezialverzahnungslehren nach Kundenzeichnungen, auf Anfrage.

**!** Gauges for involute splines, master gears and special design spline gauges according customers drawings, on request.



## Verzahnungsmessgeräte

## Serration measuring instruments



- ▶ Bitte beachten Sie unsere Verzahnungsmessgeräte Katalog Kapitel 6.

- ▶ Please note to our serration measuring instruments catalogue capture 6.



## Vergleichsmessgeräte für Verzahnungsmessung

## Comparative measuring instrument for gear measurement



- ▶ Werksnorm
- ▶ großes LCD Display
- ▶ Toleranzmarken einstellbar
- ▶ Feinzeigerablesung 0,002mm
- ▶ großer Freihub
- ▶ Handwärmeschutz
- ▶ Lieferung im Koffer, inkl. 25mm Verlängerung und Software zur Ermittlung der Prüfmaße, ohne Messkugeln (Rollen) und ohne Einstelllehre

### Funktion:

- ▶ Ein/Aus
- ▶ mm/inch Umschaltung
- ▶ 0-Punkt an jeder Position
- ▶ Ablesung umschaltbar 0,01 / 0,001mm
- ▶ Preset Funktion
- ▶ Toleranzwerteingabe
- ▶ Hold Funktion
- ▶ Datenausgang Opto

### Anwendung:

- ▶ Prüfen von Innen- und Außenverzahnungen (Die Möglichkeit der Außenverzahnungsmessung ist abhängig von Zahnradumfang und Zahnradhöhe – Gerät darf nicht aufliegen. Die Zähnezahln muss in der Software positiv anstatt negativ eingegeben werden.)
- ▶ einfache und schnelle Prüfung von großen Verzahnungen an Großbauteilen
- ▶ selbstzentrierend
- ▶ Voreinstellung mit Einstellmeister
- ▶ geringer Platzbedarf beim Prüfen von aufgespannten Werkstücken

- ▶ Works standard
- ▶ Large LCD display
- ▶ Adjustable tolerance marks
- ▶ Comparator gauge reading 0.002mm
- ▶ Large free lift
- ▶ Insulated pads
- ▶ Delivered in a box, incl. 25mm extension and software for determination of the dimensions, without measuring balls (rollers) and without setting gauges

### Funktion:

- ▶ On/Off
- ▶ mm/inch commutation
- ▶ Zero setting at any position
- ▶ Reversible reading 0.01 / 0.001mm
- ▶ Preset function
- ▶ Tolerance input
- ▶ Hold function
- ▶ Data output Opto

### Application:

- ▶ Control of internal and external gears (the possibility of measuring of external gears depends on the gear-wheel circumference and on the gear-wheel height – the instrument may not rest on the workpiece. The number of teeth must be entered into the software as positive values instead of negative ones.)
- ▶ Easy and quick control of large gears on large components
- ▶ Self-centering
- ▶ Presetting with setting master
- ▶ Small space requirement for the checking of clamped workpieces

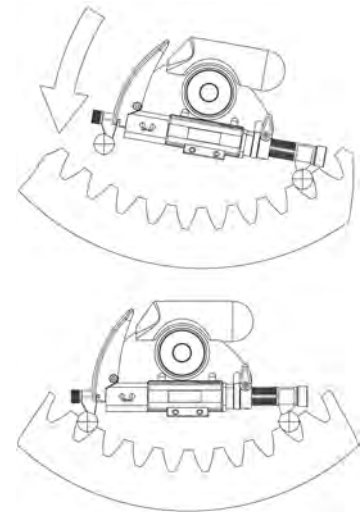

mm	inch	mm	inch	kg	Nº
175 – 225	7 – 9	0,01 0,001	.0005 .00005	1,5	1394 101
225 – 275	9 – 11	0,01 0,001	.0005 .00005	1,6	1394 102
275 – 325	11 – 13	0,01 0,001	.0005 .00005	1,7	1394 103
325 – 375	13 – 15	0,01 0,001	.0005 .00005	1,8	1394 104
375 – 425	15 – 17	0,01 0,001	.0005 .00005	1,9	1394 105

## Messtaster, Paar für Nr. 1394 1..

## Measuring probe, pair for No. 1394 1..



- ▶ Werksnorm
- ▶ Spezialstahl gehärtet
- ▶ Lieferung paarweise verpackt, inkl. Werks-Kalibrierschein

**1394 3.. :**  
Messkugel und Rolle

**1394 4.. :**  
Messkugel und Messkugelpaar

**!** Zur Festlegung des optimalen Kugeldurchmessers, bitten wir um Zusendung der kompletten Verzahnungsdaten.

- ▶ Works standard
- ▶ Hardened special steel
- ▶ Delivered in a package (pair), incl. works calibration certificate

**1394 3.. :**  
Single measuring ball and roll

**1394 4.. :**  
Single measuring ball and measuring ball pair

**!** Please send us the complete serration data to specify the optimal ball-diameter.

Kugel / Ball Ø mm	kg	Nº	Nº	Kugel / Ball Ø mm	kg	Nº	Nº
10	0,1	1394 301	1394 401	28	0,5	1394 308	1394 408
12	0,1	1394 302	1394 402	30	0,5	1394 309	1394 409
14	0,2	1394 303	1394 403	35	0,7	1394 310	1394 410
16	0,2	1394 304	1394 404	36	0,7	1394 311	1394 411
18	0,2	1394 305	1394 405	40	0,9	1394 312	1394 412
20	0,2	1394 306	1394 406	45	1,1	1394 313	1394 413
25	0,3	1394 307	1394 407	50	1,2	1394 314	1394 414

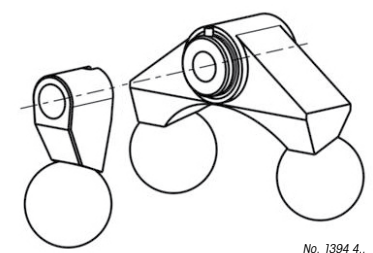
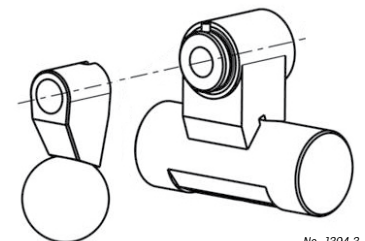

## Einstellehre für Nr. 1394 1..

## Setting gauge for No. 1394 1..



**Gehärtet  
Hardened**

- ▶ Werksnorm
- ▶ Spezialstahl gehärtet
- ▶ Lieferung einzeln verpackt

- ▶ Works standard
- ▶ Hardened special steel
- ▶ Delivered in individual packages

**1394 5.. :**  
für Kugel-Ø 10 – 20mm

**1394 5.. :**  
for ball-Ø 10 – 20mm

**1394 6.. :**  
für Kugel-Ø 25 – 50mm

**1394 6.. :**  
for ball-Ø 25 – 50mm



No. 1394 5..

l mm	g kg	Nº	Nº	l mm	g kg	Nº	Nº
200	3,7	1394 501	1394 601	325	5,4	1394 506	1394 606
225	4,0	1394 502	1394 602	350	5,8	1394 507	1394 607
250	4,3	1394 503	1394 603	375	6,2	1394 508	1394 608
275	4,6	1394 504	1394 604	400	6,6	1394 509	1394 609
300	5,0	1394 505	1394 605	425	7,0	1394 510	1394 610

## OD Messdorne für Innenverzahnungen

## OD plug gauge for internal gears



**Hartmetall  
Tungsten carbide**

- ▶ Werksnorm
- ▶ Zweipunkt-Vergleichsmessgeräte
- ▶ Messhülse verhindert Kippfehler
- ▶ Suche des Umkehrpunkts entfällt
- ▶ Taster hartmetallbestückt ~ 1600V
- ▶ Messnadel aus Hartmetall
- ▶ Messweg 0,2mm
- ▶ Anschlussgewinde M11x0,75 (M10x1 auf Anfrage)
- ▶ Messhüfraufnahme Ø 8mm
- ▶ Wiederholbarkeit der Messwerte <1µm
- ▶ Lieferung einzeln verpackt, ohne Messuhr, Griff und Einstellmeister

- ▶ Works standard
- ▶ Two-point comparative measuring instrument
- ▶ Tilt-preventing measuring sleeve
- ▶ No search for turning point
- ▶ Tungsten carbide-tipped contact points ~ 1600V
- ▶ Tungsten carbide-tipped gauge pin
- ▶ Measuring range 0.2mm
- ▶ Mounting thread M11x0.75 (M10x1 on request)
- ▶ Dial mounting hole Ø 8mm
- ▶ Repeatability of measuring values <1µm
- ▶ Delivered in individual packages without dial gauge, handle and setting gauge



Anwendungsbereich: Maß M zwischen den Kugeln min. 10mm bis max. 60mm

Range of application: Size M min. 10mm to max. 60mm between the balls

! Alle Ausführungen auf Anfrage.  
Bitte Nennmaß und Toleranz angeben,  
oder eine Zeichnung begeben.

! All executions on request.  
Please mention nominal size  
and tolerance or enclose your drawing.

## KT Innenfeinmessgeräte für Innenprofile und Innenverzahnungen

## KT Precision bore gauges for inside profiles and serrations



- ▶ Werksnorm
- ▶ Zweipunkt-Vergleichsmessgerät
- ▶ Messhüfraufnahme Ø 8mm
- ▶ Lieferung im Holzetui ohne Kugeln und Messuhr

- ▶ Works standard
- ▶ Two-point comparative measuring instrument
- ▶ Dial mounting hole Ø 8mm
- ▶ Delivered in wooden box without balls and dial gauge

! Kugeleinsätze mit Hartmetallkugeln in Ø 1 – 15mm  
bitte separat bestellen.

! Tungsten carbide ball inserts Ø 1 – 15mm  
should be separately ordered

M $\frac{M}{mm}$ mm	L mm	Messspanne Measuring span mm	Taster Gewinde Probe thread	g kg	Nº
8 – 12	100	0,6	M 1,6	0,44	1382 501
12 – 22	102	0,6	M 1,6	0,59	1382 502
22 – 55	110	1,0	M 2,5	0,64	1382 503
55 – 250	177	1,5	M 4	1,7	1382 504



No. 1382 503

No. 1382 504

## KT Hartmetall-Kugeleinsätze, Paar

## KT Tungsten carbide ball inserts, pair



**Hartmetall  
Tungsten carbide**

- ▶ für Innenfeinmessgeräte Serie Nr. 1382 5..
- ▶ Stufung 0,5mm
- ▶ Lieferung paarweise verpackt

- ▶ for precision bore gauges series No. 1382 5..
- ▶ Step 0.5mm
- ▶ Delivered in a package (pair)

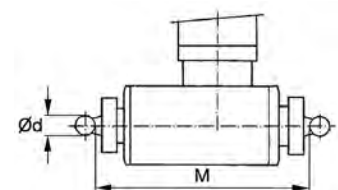

M = Messbereich ohne Kugeln  
M = Measuring range without balls

! Siehe Katalog Seite 6. 18.

! Please see catalogue page 6. 18.

## Universalvergleichsmessgerät QUICK CHECK

## Universal comparative measuring bench QUICK CHECK



TOP



Gehärtet  
Hardened

- ▶ Werksnorm
- ▶ Innen- und Außenmessung
- ▶ schnelle, genaue und sichere Messung
- ▶ Messfläche aus rostfreiem, gehärtetem Stahl
- ▶ 1 einstellbarer, 1 beweglicher Taster (Messweg 20mm)
- ▶ Messkraft einstellbar 0 – 10N
- ▶ Wiederholgenauigkeit ±0,001mm
- ▶ Messuhraufnahme Ø 8mm
- ▶ Tasteraufnahme Ø 8mm
- ▶ Lieferung im Koffer ohne Messuhr

### Inhalt:

- ▶ Universalvergleichsmessgerät
- ▶ Messuhrverlängerung 20mm
- ▶ Feststellsegment
- ▶ Werkstückauflage 1 Paar
- ▶ Taster mit Kugel Ø 10mm 1 Paar
- ▶ Taster mit Teller Ø 16mm 1 Paar

### Anwendungen:

- ▶ Prüfen von Innen- und Außenmaßen, mit Sondermess-einsätzen auch in Nuten und Einstichen
- ▶ Verzahnungsmessung mit Messkugeln im Halter Nr. 2050 3.. und Adapterbolzen Nr. 1390 311

- ▶ Works standard
- ▶ Inside and outside measurements
- ▶ Fast, precise and safe measurements
- ▶ Hardened measuring surface made of stainless steel
- ▶ 1 adjustable and 1 movable probes (meas. way 20mm)
- ▶ Adjustable measuring force 0 – 10N
- ▶ Repeatability ±0.001mm
- ▶ Dial mounting hole Ø 8mm
- ▶ Probe mounting hole Ø 8mm
- ▶ Delivered in box without dial gauge

### Contents:

- ▶ Universal comparative measuring instruments
- ▶ Dial indicator extension 20mm
- ▶ Clamping segment
- ▶ Work piece supports 1 pair
- ▶ Ball probes Ø 10mm 1 pair
- ▶ Disc probes Ø 16mm 1 pair

### Applications:

- ▶ Inside and outside measurements, with special measuring inserts also in slots and recesses
- ▶ Gear tooth measurements with measuring balls in holder No. 2050 3.. and adaptor bolts No. 1390 311



Messrichtungsumkehr  
Messkraft stufenlos einstellbar  
Reversible measuring direction  
Adjustable measuring force

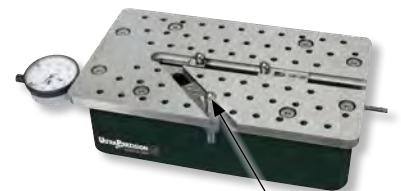

innen / inside mm	außen / outside mm	L mm	kg	Nº
20 – 200	0 – 180	150 x 255	6,3	1390 101
20 – 350	0 – 330	406 x 180	7,1	1390 102
Zusätzl. Anschlag / Add. Anvil				
20 – 200 / 45°	0 – 180 / 45°	150 x 255	6,3	1390 103

## Universalvergleichsmessgerät QUICK CHECK für Dreipunktmessung

## Universal comparative measuring bench QUICK CHECK for 3-point measurement



NEW



Gehärtet  
Hardened

- ▶ Werksnorm
- ▶ Innen- und Außenmessung
- ▶ schnelle, genaue und sichere Messung
- ▶ Messfläche aus rostfreiem, gehärtetem Stahl
- ▶ 2 einstellbare, 1 beweglicher Taster (Messweg 20mm)
- ▶ Messkraft einstellbar 0 – 10N
- ▶ Wiederholgenauigkeit ± 0,001mm
- ▶ Messuhraufnahme Ø8mm
- ▶ Tasteraufnahme Ø8mm
- ▶ Lieferung im Koffer ohne Messuhr

### Inhalt:

- ▶ Universalvergleichsmessgerät
- ▶ Messuhrverlängerung 20mm
- ▶ Feststellsegment
- ▶ Taster mit Kugel Ø 10mm, 3 Stück

### Anwendungen:

- ▶ Schnelle und sichere Serienmessung von Innen- und Außenmaßen, mit Sondermesseinsätzen auch in Nuten und Einstichen

- ▶ Works standard
- ▶ Inside and outside measurements
- ▶ Fast, precise and safe measurements
- ▶ Hardened measuring surface made of stainless steel
- ▶ 2 adjustable and 1 movable probes (meas. way 20mm)
- ▶ Adjustable measuring force 0 – 10N
- ▶ Repeatability ± 0.001mm
- ▶ Dial mounting hole Ø8mm
- ▶ Probe mounting hole Ø8mm
- ▶ Delivered in box without dial gauge

### Contents:

- ▶ Universal comparative measuring instrument
- ▶ Dial indicator extension 20mm
- ▶ Clamping segment
- ▶ Ball probes Ø 10mm, 3 pieces

### Applications:

- ▶ Fast and safe series measurement of inside and outside dimensions, with special measuring inserts also in slots and recesses

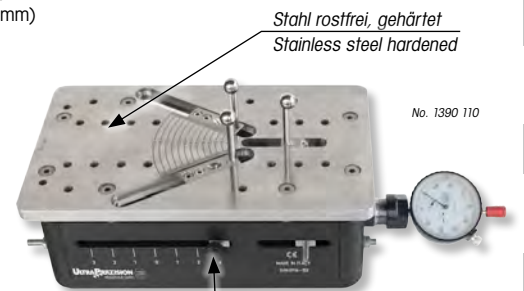

Messrichtungsumkehr  
Messkraft stufenlos einstellbar  
Reversible measuring direction  
Adjustable measuring force

**I** Der angegebene Messbereich bezieht sich auf Kugeltaster Ø 10mm. **I** The mentioned measuring range refers to ball probes Ø 10mm.

innen/inside mm	außen/outside mm	L mm	kg	Nº
48 – 128	28 – 103	150x255	7,6	1390 110

## Prismatischer Anschlag für QUICK CHECK

## V stop for QUICK CHECK



- ▶ Werksnorm
- ▶ Spezialstahl gehärtet
- ▶ Zur schnellen, sicheren Durchmesserprüfung ohne Umkehrpunktsuche
- ▶ Wiederholungsgenauigkeit der Mechanik  $\pm 0,001\text{mm}$
- ▶ Lieferung einzeln verpackt ohne Quick Check und Messuhr

### Handhabung:

- ▶ Das Prisma ist in der Nute verschiebbar und kann auf verschiedene Durchmesser eingestellt werden.
- ▶ Die Voreinstellung erfolgt mittels Einstellmeister oder Prüfscheibe.
- ▶ Der erforderliche Korrekturfaktor wird in der Messuhr eingegeben und bleibt gespeichert.
- ▶ Die Korrektur des Messwertes erfolgt automatisch.
- ▶ Der Anwender liest das exakte Messergebnis direkt auf dem Messuhrdisplay ab.
- ▶ Weitere Berechnungen sind nicht erforderlich.

- ▶ Works standard
- ▶ Special steel hardened
- ▶ For a reliable diameter measuring, no search of the reversal point.
- ▶ Repeatability of the mechanic  $\pm 0.001\text{mm}$
- ▶ Delivered in individual packages without QUICK CHECK and dial gauge

### Operation:

- ▶ The V anvil can be slid in the slot and adjusted for different diameters.
- ▶ The pre-setting through setting master or an optical flat.
- ▶ The required correction factor is entered into the dial gauge display and shall remain saved.
- ▶ The correction of the measured value follows automatically.
- ▶ The user reads the exact measuring result on the dial gauge display directly.
- ▶ Further calculations are not necessary.

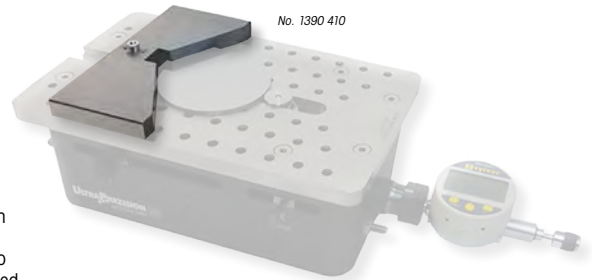

! Es wird eine Messuhr mit Umrechnungsfaktor-Funktion benötigt. Wir empfehlen unsere Messuhr Nr. 1301 106 (siehe Seite 4.3)

! A dial gauge with conversion factor – function is needed. We recommend our dial gauge no. 1301 106 (see page 4.3)

! Der angegebene Werkstück  $\varnothing$  bezieht sich auf das Basisgerät QUICK CHECK Nr. 1390 101

! The mentioned workpiece  $\varnothing$  refers to standard QUICK CHECK no. 1390 101

L mm	max. Werkstück max. Workpiece $\varnothing$ mm	kg	Nº
150x10	135mm	0,5	1390 410

> Werkstück  $\varnothing$  auf Anfrage / > Workpiece  $\varnothing$  on request

## Halter für QUICK CHECK zum Kippen der Messfläche

## Holder for QUICK CHECK to tilt measuring surface



- ▶ Optimale Positionierung des Werkstücks durch schräggestellte Messfläche
- ▶ Lieferung einzeln verpackt

- ▶ Optimal positioning of the workpiece with bevelled meas. surface
- ▶ Delivered in individual packages



$\angle$	kg	Nº
Schrägstellung Messfläche 10° bis 40° Bevelled meas. surface 10° to 40°	0,5	1390 401

## Messeinsätze für QUICK CHECK, Paar

## Probes for QUICK CHECK, pair



- ▶ Spezialstahl gehärtet
- ▶ Lieferung als Paar einzeln verpackt

- ▶ Special steel hardened
- ▶ Delivered as pair in individual packages

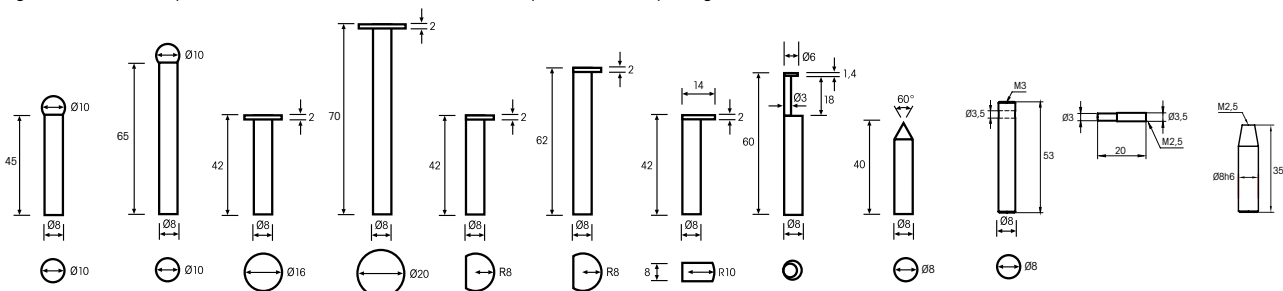

Zubehör für Spezialanwendungen auf Anfrage.  
Special application accessories on request.

Nº	1390 301	1390 302	1390 303	1390 304	1390 305	1390 306	1390 307	1390 308	1390 309	1390 310	1390 311	1390 300
----	----------	----------	----------	----------	----------	----------	----------	----------	----------	----------	----------	----------

**Universalvergleichsmessgerät QUICK CHECK mit höhenverstellbarem Tisch (0-28mm)**

**Universal comparative measuring bench QUICK CHECK with height adjustable table (0-28mm)**



- ▶ Werksnorm
- ▶ Innen- und Außenmessung
- ▶ X- und Z-Achse
- ▶ Rechtwinkligkeit 0,01mm
- ▶ Zur Ø-Prüfung auf unterschiedlichen Messebenen
- ▶ schnelle, genaue und sichere Messung
- ▶ Messfläche aus rostfreiem, gehärtetem Stahl 50 HRC
- ▶ 1 einstellbarer, 1 beweglicher Taster (Messweg 20mm)
- ▶ Messkraft einstellbar 0 -10N
- ▶ Wiederholgenauigkeit ±0,001mm
- ▶ Messuhraufnahme Ø 8mm
- ▶ Tasteraufnahme Ø 8mm
- ▶ Lieferung im Koffer ohne Messuhr

**Inhalt:**

- ▶ Universalvergleichsmessgerät
- ▶ Messuhrverlängerung 20mm
- ▶ Feststellsegment
- ▶ Werkstückauflage 1 Paar
- ▶ Taster mit Kugel Ø 10mm 1 Paar
- ▶ Taster mit Teller Ø 16mm 1 Paar

**Anwendungen:**

- ▶ Prüfen von Innen- und Außenmaßen, mit Sondermess-einsätzen auch in Nuten und Einstichen
- ▶ Verzahnungsmessung mit Messkugeln im Halter Nr. 2050 3.. und Adapterbolzen Nr. 1390 311

- ▶ Works standard
- ▶ Inside and outside measurements
- ▶ X- and Z-axis
- ▶ Rectangularity 0.01mm
- ▶ For Ø-check on different measuring levels
- ▶ Fast, precise and safe measurements
- ▶ Hardened measuring surface made of stainless steel 50 HRC
- ▶ 1 adjustable and 1 movable probes (meas. way 20mm)
- ▶ Adjustable measuring force 0 -10N
- ▶ Repeatability ±0.001mm
- ▶ Dial mounting hole Ø 8mm
- ▶ Probe mounting hole Ø 8mm
- ▶ Delivered in box without dial gauge

**Contents:**

- ▶ Universal comparative measuring instruments
- ▶ Dial indicator extension 20mm
- ▶ Clamping segment
- ▶ Work piece supports 1 pair
- ▶ Ball probes Ø 10mm 1 pair
- ▶ Disc probes Ø 16mm 1 pair

**Applications:**

- ▶ Inside and outside measurements, with special measuring inserts also in slots and recesses
- ▶ Gear tooth measurements with measuring balls in holder No. 2050 3.. and adaptor bolts No. 1390 311

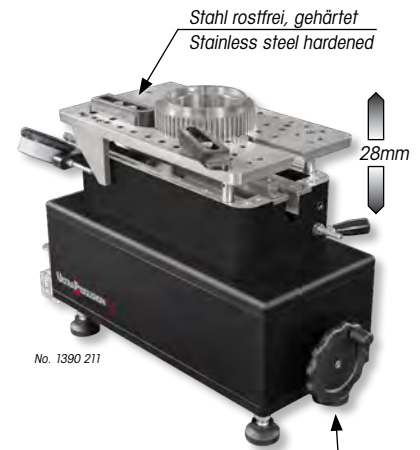
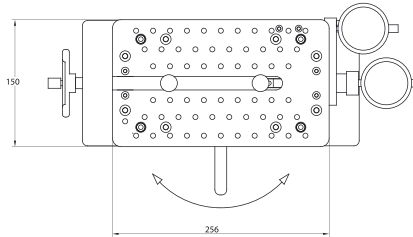
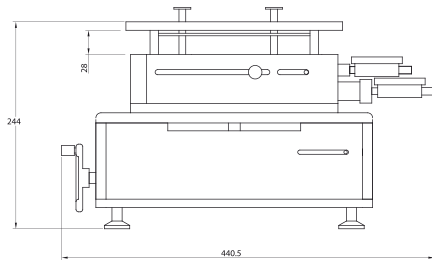

Tischhöhe Feineinstellung mit Handrad  
Table height fine adjustment with hand wheel

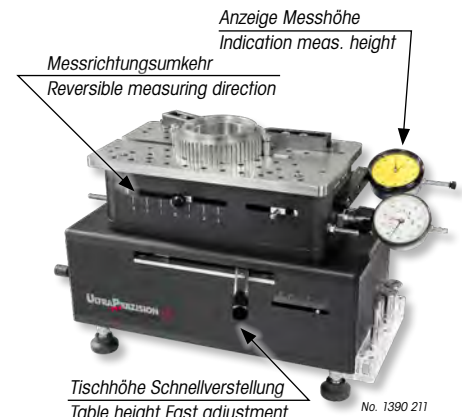

innen / inside mm	außen / outside mm	L mm	kg	Nº
20 - 200	0 - 180	150 x 255	12,7	1390 211

**Messtaster Adapter-Set für QUICK CHECK**

**Probe adapter set for QUICK CHECK**



- ▶ Messtaster Paar Ø 8x53mm mit Aufnahmebohrung Ø 3,5mm
- ▶ Messeinsatzadapter Paar Ø 3/3,5mm mit Innengewinde M2,5 (für Messeinsätze ULTRA No. 1330 ... Kat.Seite 4.16 und ULTRA No. 2050 3..)
- ▶ Messtaster Paar Ø 8x45mm oben mit Innengewinde M2,5 (für Messeinsätze ULTRA No. 1330 ... Kat.Seite 4.16)
- ▶ Fluchtdorn Ø 3,5x50mm
- ▶ Lieferung im Holzetui

- ▶ Probe pair Ø 8x53mm with mounting hole 3.5mm
- ▶ Adapter pair with Ø 3/3.5mm and inside thread M2.5 (for inserts ULTRA No. 1330 ... cat. page 4.16 and ULTRA No. 2050 3..)
- ▶ Probe pair Ø 8x45mm with inside thread M2.5 at top (for inserts ULTRA No. 1330 ... cat. page 4.16)
- ▶ Aligning mandrel Ø 3.5x50mm
- ▶ Delivered in wooden case

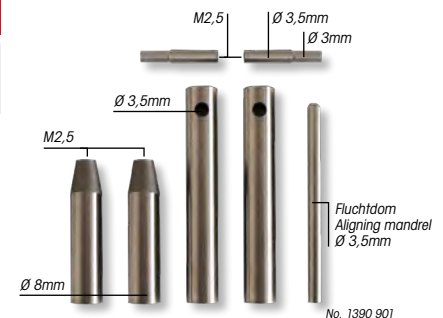

**Anwendungen:**

- ▶ Mit diesem Zubehörsatz können alle Messeinsätze für Messuhren mit Gewinde M2,5 sowie Messkugeln im Halter adaptiert werden.
- Ihr QUICK CHECK Universalmessgerät wird einfach und kostengünstig, auf ständig neue Messaufgaben angepasst.

**Applications:**

- ▶ With this accessories you can adapt all measuring inserts for dial gauges with thread M2.5 as well as measuring balls in holder.
- You can modify your QUICK CHECK universal measuring bench for your daily new measuring applications, easily and cost saving.

Satz Set	L mm	kg	Nº
7 Stck. / 7 pieces	150 x 50 x 20	0,3	1390 901

**Anwendung / Application:**



**Vergleichsmessgeräte  
für Innen- und Außenverzahnung**

**Comparative measuring instruments  
for gear tooth inside and outside**

► weitere Modelle in Kapitel 6

► other models in chapter 6

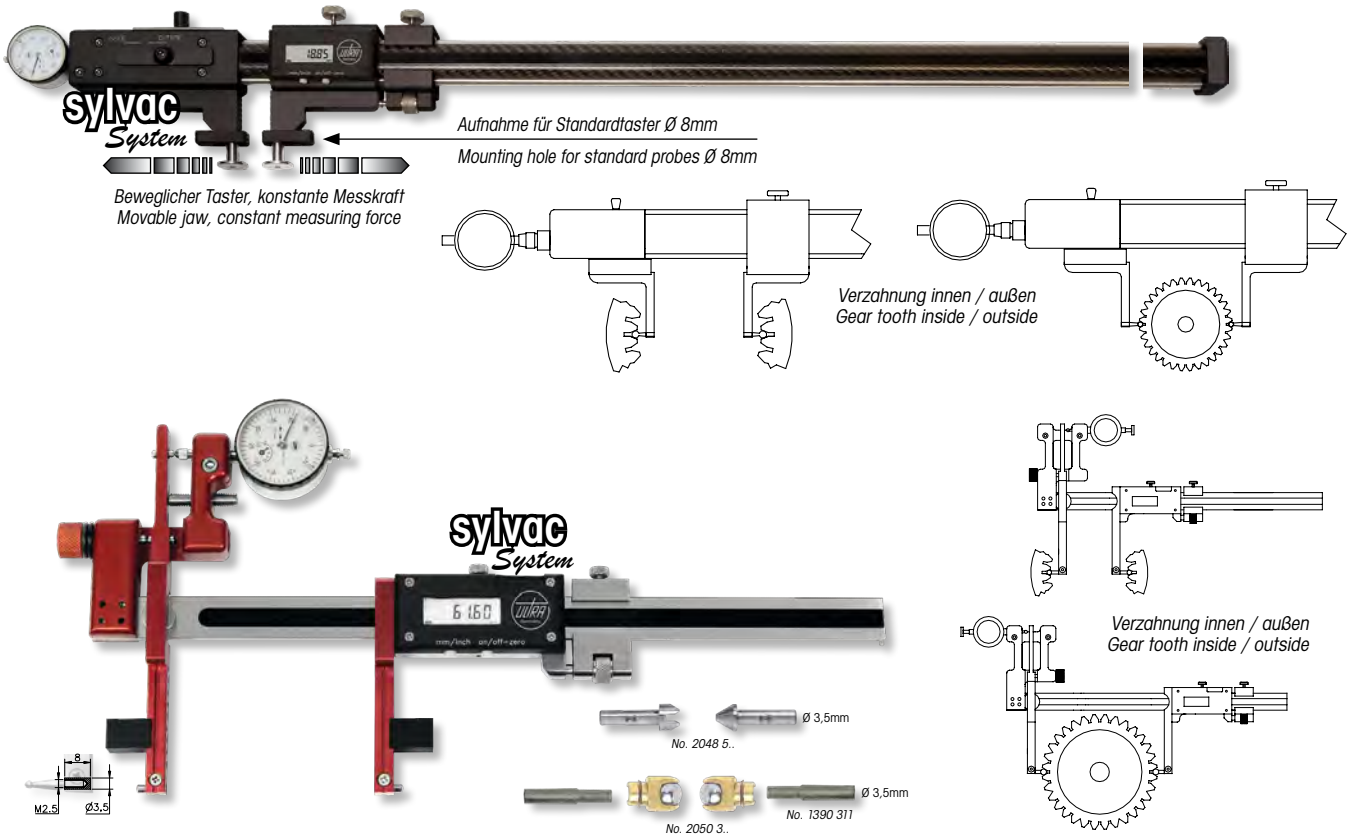

**Messschrauben  
für Innen- und Außenverzahnung**

**Micrometers  
for gear tooth inside and outside**

► weitere Modelle in Kapitel 13

► other models in chapter 13

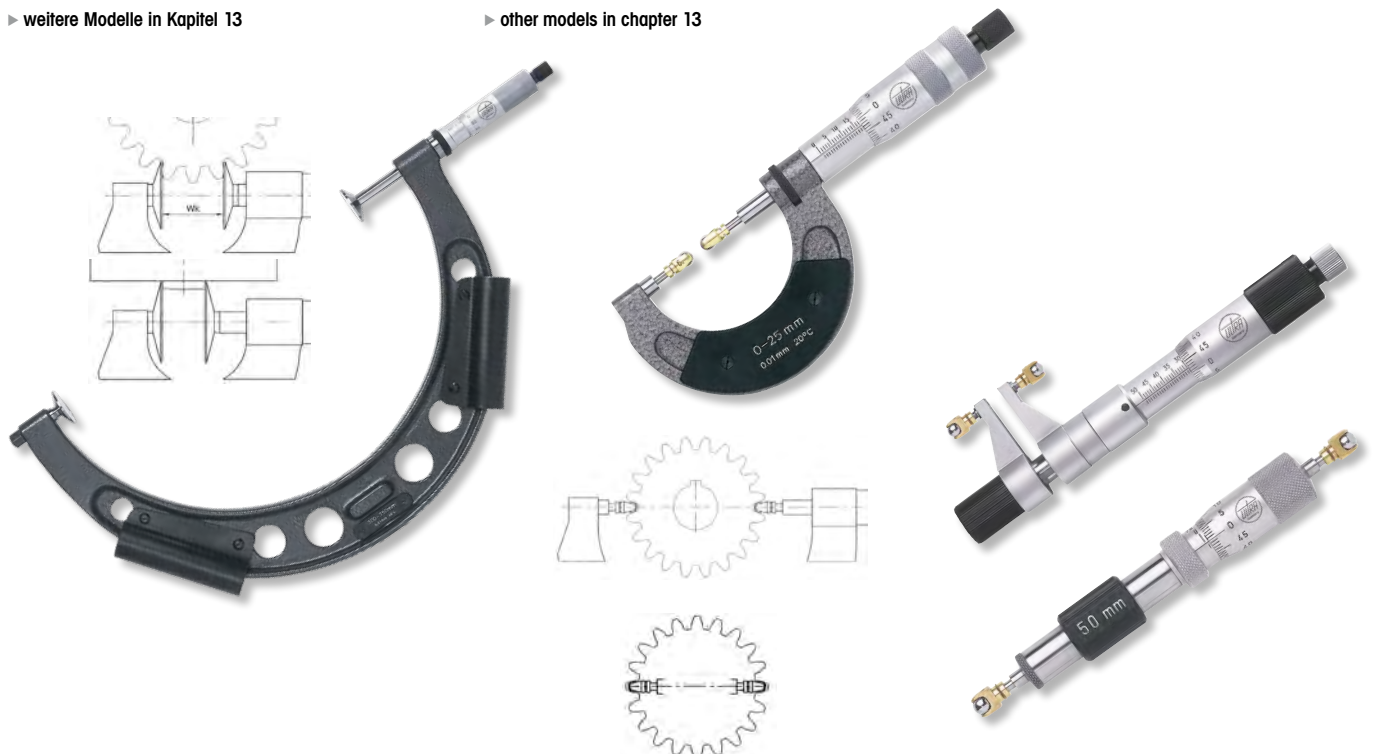



# 4

**Feinzeiger**  
Comparator gauges

**Messuhren**  
Dial gauges

**Fühlhebelmessgeräte**  
Dial test indicators



Sylvac S\_Dial Work ADVANCED  
Sylvac S\_Dial Work ADVANCED

4.4

Sylvac S\_Dial Work NANO  
Sylvac S\_Dial Work NANO

4.5

Sylvac S\_Dial Work ANALOG  
Sylvac S\_Dial Work ANALOG

4.5

Feinzeiger MYCRO  
Comparator gauges, MYCRO

4.7

### Digital-Messuhren

überzeugen durch hohe Genauigkeit und robuste, mechanische Komponenten. Die Herstellung erfolgt nach Werksnorm. Für besondere Einsatzbedingungen sind Modelle mit Schutzart IP 65 lieferbar.

### Feinzeiger mit Skala

bieten ein Größtmaß an Präzision und Messsicherheit. Die Zeigerfeineinstellung ist feinfühlig und zugleich stabil. Alle Modelle sind stoßgeschützt mit zusätzlichem Freihub. Sie entsprechen in allen messtechnischen Merkmalen und Abmessungen der DIN 879-1.

### Messuhren mit Skala

zeichnen sich durch robuste Konstruktion, hohe Genauigkeit, Zuverlässigkeit und lange Lebensdauer aus. Die messtechnischen Merkmale und Abmessungen aller Modelle mit 0,01 mm Skalenteilungswert, Messspanne bis 10 mm, und Außenring Ø bis 62 mm, entsprechen der DIN 878 bzw. der Werksnorm. Alle anderen Modelle werden nach Werksnormen hergestellt, die wir auf Wunsch gerne zur Verfügung stellen.

### Digital-Fühlhebelmessgeräte

überzeugen durch höchste Genauigkeit und Zuverlässigkeit. Die Taster sind schwenkbar, eine Rutschkupplung schützt das Geräte gegen Stöße. Die Herstellung erfolgt nach Werksnorm.

### Fühlhebelmessgeräte mit Skala

haben eine hohe Feinfühligkeit. Die Taster sind schwenkbar, eine Rutschkupplung schützt das Messwerk gegen Stöße. Die Gehäuse sind hartverchromt um Beschädigungen zu vermeiden. Die Herstellung erfolgt nach DIN 2270.

### Kalibrierung:

Für alle Messuhren und Fühlhebelmessgeräte können Werkskalibrierscheine erstellt werden. Eine DAkkS Kalibrierung durch ein akkreditiertes Labor ist für die meisten Modelle ebenfalls möglich.

Bitte beachten Sie hierzu unsere Nettopreisliste für die Erstellung von Prüfberichten.

Weitere Informationen erhalten Sie unter:

[www.ultra-germany.com](http://www.ultra-germany.com) > Produkte > Service > Prüfmittelüberwachung

### Sonderzifferblätter für Messuhren:

Viele Modelle aus unserem breiten Sortiment können mit Sonderzifferblättern geliefert werden. Zur Angebotserstellung bitten wir um Ihre Anfrage mit Prinzipskizze.

### Beispiele möglicher Sonderzifferblätter:



Zifferblätter mit farbigem Toleranzfeld in rot, grün oder gelb

Dial with coloured tolerance fields in red, green or yellow



Zifferblätter linkslaufend beziffert

Dial numerals from right to left

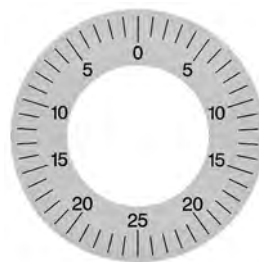

Zifferblätter beidseitig beziffert

Dial numerals on both sides



Zifferblätter nach Kundenzeichnung

Dial as per customer drawing

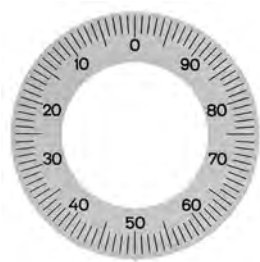

**Digital-Messuhren S\_Dial Work ADVANCED mit LED Toleranzampel**

**Digital dial indicators S\_Dial Work ADVANCED with LED tolerance signal lights**



No. 1301 10.

- ▶ Werksnorm
- ▶ Schutzart IP51
- ▶ induktives Messsystem
- ▶ großes LCD-Display, drehbar 270°
- ▶ Individuell programmierbare Taste
- ▶ Wiederholbarkeit 0,002mm
- ▶ Aluminiumgehäuse Ø 60mm
- ▶ Einspannschaft Ø 8mm h6
- ▶ Messeinsatz M2,5 auswechselbar
- ▶ Lieferung in Kartonbox

- ▶ Works standard
- ▶ Protection class IP51
- ▶ Inductive measuring system
- ▶ Large LCD display, turnable up to 270°
- ▶ Individually programmable key with required functions
- ▶ Repeatability 0.002mm
- ▶ Aluminium housing Ø 60mm
- ▶ Clamping shaft Ø 8mm h6
- ▶ Interchangeable measuring insert M2.5
- ▶ Delivered in a cardboard box

**Funktionen:**

- ▶ Ein/Aus
- ▶ Auto-Off
- ▶ mm/inch Umschaltung
- ▶ 0-Punkt an jeder Position (2 Referenzpunkte)
- ▶ Hold Funktion
- ▶ ± Preset Funktion
- ▶ MIN / MAX Wertspeicher
- ▶ Umrechnungsfaktor
- ▶ Toleranzampel LED rot/grün/gelb
- ▶ Messrichtungsumkehr
- ▶ Absolut Funktion
- ▶ Tastensperre
- ▶ Datenausgang Proximity

**Functions:**

- ▶ On/Off
- ▶ Auto-Off
- ▶ mm/inch commutation
- ▶ Zero setting at any position (2 reference points)
- ▶ Hold function
- ▶ ± Preset function
- ▶ MIN. / MAX. memory
- ▶ Conversion factor
- ▶ Tolerance signal lights LED red/green/yellow
- ▶ Reversible measuring direction
- ▶ Absolute function
- ▶ Key lock
- ▶ Data output Proximity

**1301 101 – 1301 104x :**  
ohne Werks-Kalibrierschein

**1301 101 – 1301 104x :**  
without works calibration certificate

**1301 105 – 1301 109 :**  
inkl. Werks-Kalibrierschein

**1301 105 – 1301 109 :**  
incl. works calibration certificate

mm / inch	mm / inch	Fehler / Error max mm	N	kg	Nº
12,5 / .5	0,01 / .0005	0,01	0,65 – 0,9	0,21	1301 101
25 / 1	0,01 / .0005	0,01	0,65 – 1,15	0,23	1301 102
50 / 2	0,01 / .0005	0,02	1,4 – 2,9	0,25	1301 103
100 / 4	0,01 / .0005	0,02	1,8 – 3,8	0,26	1301 104
150 / 6	0,01 / .0005	0,02	2,6 – 5,7	0,28	1301 104x
12,5 / .5	0,001 / .00005	0,003	0,65 – 0,9	0,21	1301 105
25 / 1	0,001 / .00005	0,004	0,65 – 1,15	0,23	1301 106
50 / 2	0,001 / .00005	0,005	1,4 – 2,9	0,25	1301 107
100 / 4	0,001 / .00005	0,006	1,8 – 3,8	0,26	1301 108
150 / 6	0,001 / .00005	0,01	2,6 – 5,7	0,28	1301 109
Datenkabel RS232 (2m) / Data cable RS232 (2m)					1850 203ip
Datenkabel USB (2m) / Data cable USB (2m)					1850 204ip

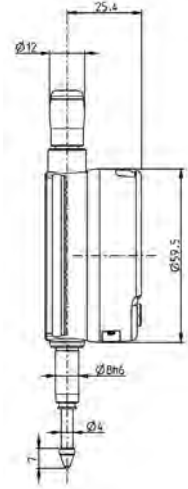

**Messuhren Zubehör für S\_Dial Work ADVANCED**

**Dial gauge accessories for S\_Dial Work ADVANCED**



▶ Lieferung einzeln verpackt

▶ Delivered in individual packages

Typ Type	Nº
Abhebevorrichtung für Messweg 12,5mm / Lifting device for measuring way 12.5mm	1334 101
Abhebevorrichtung für Messweg 25mm / Lifting device for measuring way 25mm	1334 102
Rückendeckel mit Öse / Back cover with lug	1334 201

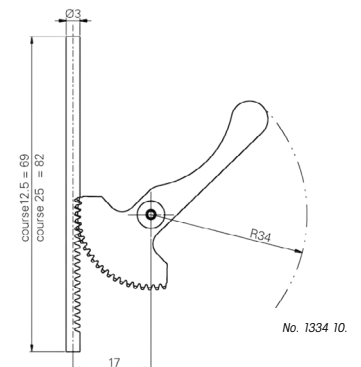

No. 1334 10.

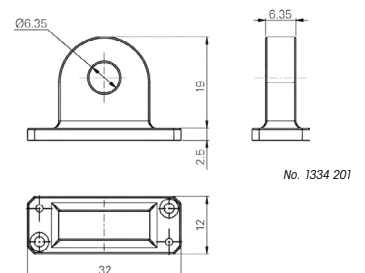

No. 1334 201

## Digital-Messuhren S\_Dial Work ADVANCED mit Bluetooth-Funktion

## Digital dial indicators S\_Dial Work ADVANCED with Bluetooth function

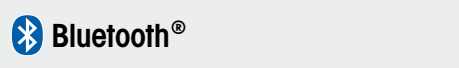

- ▶ Werksnorm
- ▶ Schutzart IP65
- ▶ induktives Messsystem
- ▶ großes LCD-Display, drehbar 270°
- ▶ Individuell programmierbare Taste
- ▶ Wiederholbarkeit 0,002mm
- ▶ Aluminiumgehäuse Ø 60mm
- ▶ Einspannschaft Ø 8mm h6
- ▶ Messeinsatz M2,5 auswechselbar
- ▶ Lieferung in Kartonbox inkl. Werks-Kalibrierschein

### Funktionen:

- ▶ Ein/Aus
- ▶ Auto-Off
- ▶ mm/inch Umschaltung
- ▶ 0-Punkt an jeder Position (2 Referenzpunkte)
- ▶ Hold Funktion
- ▶ ± Preset Funktion
- ▶ MIN / MAX Wertspeicher
- ▶ Umrechnungsfaktor
- ▶ Toleranzampel LED rot/grün/gelb
- ▶ Messrichtungsumkehr
- ▶ Absolut Funktion
- ▶ Tastensperre
- ▶ Datenausgang Proximity

- ▶ Works standard
- ▶ Protection class IP65
- ▶ Inductive measuring system
- ▶ Large LCD display, turnable up to 270°
- ▶ Individually programmable key with required functions
- ▶ Repeatability 0.002mm
- ▶ Aluminium housing Ø 60mm
- ▶ Clamping shaft Ø 8mm h6
- ▶ Interchangeable measuring insert M2.5
- ▶ Delivered in a cardboard box incl. works calibration certificate

### Functions:

- ▶ On/Off
- ▶ Auto-Off
- ▶ mm/inch commutation
- ▶ Zero setting at any position (2 reference points)
- ▶ Hold function
- ▶ ± Preset function
- ▶ MIN. / MAX. memory
- ▶ Conversion factor
- ▶ Tolerance signal lights LED red/green/yellow
- ▶ Reversible measuring direction
- ▶ Absolute function
- ▶ Key lock
- ▶ Data output Proximity

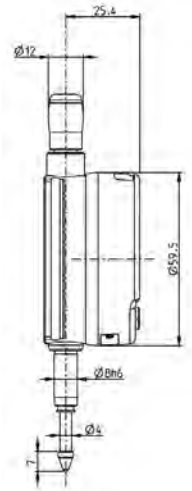

mm / inch	mm / inch	Fehler / Error max mm	N	kg	Nº
12,5 / .5	0,001 / .00005	0,003	0,65 – 0,9	0,21	1301 105b
25 / 1	0,001 / .00005	0,004	0,65 – 1,15	0,23	1301 106b
50 / 2	0,001 / .00005	0,005	1,4 – 2,9	0,25	1301 107b
100 / 4	0,001 / .00005	0,006	1,8 – 3,8	0,26	1301 108b
Datenkabel RS232 (2m) / Data cable RS232 (2m)					1850 203ip
Datenkabel USB (2m) / Data cable USB (2m)					1850 204ip
Bluetooth-Dongel (USB) zur kabellosen Datenübertragung (inkl. Treiber und Gage-Wedge Software)					1850 215
Bluetooth-Dongle (USB) for wireless data transmission (incl. driver and Gage-Wedge software)					



No. 1301 10.b

Bluetooth®



No. 1850 215



## Digital-Messuhren S\_Dial Work NANO mit LED Toleranzampel

## Digital dial indicators S\_Dial Work NANO with LED tolerance signal lights



- ▶ Werksnorm
- ▶ Schutzart IP51
- ▶ induktives Messsystem
- ▶ großes LCD-Display, drehbar 270°
- ▶ Individuell programmierbare Taste
- ▶ Wiederholbarkeit 0,0005mm
- ▶ Aluminiumgehäuse Ø 60mm
- ▶ Einspannschaft Ø 8mm h6
- ▶ Messeinsatz M2,5 auswechselbar
- ▶ Lieferung in Kartonbox, inkl. Werks-Kalibrierschein

- ▶ Works standard
- ▶ Protection class IP51
- ▶ Inductive measuring system
- ▶ Large LCD display, turnable up to 270°
- ▶ Individually programmable key with required functions
- ▶ Repeatability 0.0005mm
- ▶ Aluminium housing Ø 60mm
- ▶ Clamping shaft Ø 8mm h6
- ▶ Interchangeable measuring insert M2.5
- ▶ Delivered in a cardboard box incl. works calibration certificate

### Funktionen:

- ▶ Ein/Aus
- ▶ Auto-Off
- ▶ mm/inch Umschaltung
- ▶ 0-Punkt an jeder Position (2 Referenzpunkte)
- ▶ Hold Funktion
- ▶ ± Preset Funktion
- ▶ MIN / MAX Wertspeicher
- ▶ Toleranzampel LED rot/grün/gelb
- ▶ Messrichtungsumkehr
- ▶ Absolut Funktion
- ▶ Tastensperre
- ▶ Datenausgang Proximity

### Functions:

- ▶ On/Off
- ▶ Auto-Off
- ▶ mm/inch commutation
- ▶ Zero setting at any position (2 reference points)
- ▶ Hold function
- ▶ ± Preset function
- ▶ MIN. / MAX. memory
- ▶ Tolerance signal lights LED red/green/yellow
- ▶ Reversible measuring direction
- ▶ Absolute function
- ▶ Key lock
- ▶ Data output Proximity

mm / inch	Δε mm / inch	Fehler / Error max. mm	N N	kg	Nº
12,5 / .5	0,0001 / .00005	0,0018	0,65 – 0,9	0,21	1300 101
25 / 1	0,0001 / .00005	0,0022	0,65 – 1,15	0,23	1300 102
Datenkabel RS232 (2m) / Data cable RS232 (2m)					1850 203ip
Datenkabel USB (2m) / Data cable USB (2m)					1850 204ip

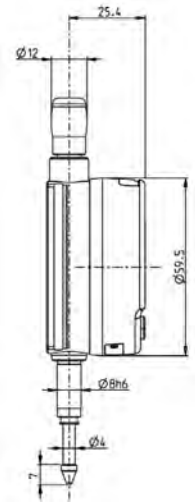

## Digital-Messuhren S\_Dial Work ANALOG mit kombinierter Skalenanzeige

## Digital dial indicators S\_Dial Work ANALOG with combined scale



- ▶ Werksnorm
- ▶ induktives Messsystem
- ▶ großes LCD-Display, drehbar 270°
- ▶ Wiederholbarkeit 0,002mm
- ▶ Aluminiumgehäuse Ø 60mm
- ▶ Einspannschaft Ø 8mm h6
- ▶ Messeinsatz M2,5 auswechselbar
- ▶ Lieferung in Kartonbox, inkl. Werks-Kalibrierschein

- ▶ Works standard
- ▶ Inductive measuring system
- ▶ Large LCD display, turnable up to 270°
- ▶ Repeatability 0.002mm
- ▶ Aluminium housing Ø 60mm
- ▶ Clamping shaft Ø 8mm h6
- ▶ Interchangeable measuring insert M2.5
- ▶ Delivered in a cardboard box incl. works calibration certificate

### Funktionen:

- ▶ Ein/Aus
- ▶ Auto-Off
- ▶ mm/inch Umschaltung
- ▶ 0-Punkt an jeder Position (2 Referenzpunkte)
- ▶ Hold Funktion
- ▶ ± Preset Funktion
- ▶ MIN / MAX Wertspeicher
- ▶ Toleranzmarken einstellbar
- ▶ Toleranzampel LED rot/grün/gelb
- ▶ Messrichtungsumkehr
- ▶ Absolut Funktion
- ▶ Tastensperre
- ▶ Datenausgang Proximity

### Functions:

- ▶ On/Off
- ▶ Auto-Off
- ▶ mm/inch commutation
- ▶ Zero setting at any position (2 reference points)
- ▶ Hold function
- ▶ ± Preset function
- ▶ MIN. / MAX. memory
- ▶ Adjustable tolerance marks
- ▶ Tolerance signal lights LED red/green/yellow
- ▶ Reversible measuring direction
- ▶ Absolute function
- ▶ Key lock
- ▶ Data output Proximity

mm / inch	Δε mm / inch	Fehler / Error max. mm	N N	kg	Nº
12,5 / .5	0,001 / .00005	0,003	0,65 – 0,9	0,21	1304 101
25 / 1	0,001 / .00005	0,004	0,65 – 1,15	0,23	1304 102
Datenkabel RS232 (2m) / Data cable RS232 (2m)					1850 203ip
Datenkabel USB (2m) / Data cable USB (2m)					1850 204ip



## Digital-Kleinmessuhren Präzisionsausführung Digital dial indicators, small precision model



- ▶ Werksnorm
- ▶ Schutzart IP (siehe Tabelle)
- ▶ großes LCD-Display
- ▶ induktives Messsystem
- ▶ Wiederholbarkeit 0,002mm
- ▶ Kunststoffgehäuse Ø 44mm
- ▶ Einspannschaft Ø 8mm h6
- ▶ rückseitige Schwabenschwanzführung
- ▶ Messeinsatz M2,5 auswechselbar
- ▶ Lieferung in Kartonbox

### Funktionen:

- ▶ Ein/Aus
- ▶ Auto OFF
- ▶ mm/inch Umschaltung
- ▶ 0-Punkt an jeder Position
- ▶ ABS / Relativ Modus
- ▶ Hold Funktion
- ▶ ± Preset Funktion
- ▶ Datenausgang

- ▶ Works standard
- ▶ Protection class IP (see table)
- ▶ large LCD display
- ▶ Inductive measuring system
- ▶ Repeatability 0,002mm
- ▶ Plastic housing Ø 44mm
- ▶ Clamping shaft Ø 8mm h6
- ▶ Dovetail slide on the back side
- ▶ Interchangeable measuring insert M2.5
- ▶ Delivered in a cardboard box

### Functions:

- ▶ On/Off
- ▶ Auto OFF
- ▶ mm/inch commutation
- ▶ Zero setting at any position
- ▶ ABS / Relative mode
- ▶ Hold function
- ▶ ± Preset function
- ▶ Data output

### 1303 1.. :

Digital-Kleinmessuhren

### 1303 1.. :

Digital dial indicators, small

### 1303 2..ip:

Schutzart IP 65

### 1303 2..ip:

Protection class IP 65

! Ausführungen mit erhöhter oder reduzierter Messkraft auf Anfrage. ! Versions with increased or reduced measuring force on request.

mm / inch	mm / inch	Fehler / Error max mm	N	IP	kg	Nº
12,5 / .5	0,01 / .0005	0,02	0,5 - 0,9	51	0,07	1303 101
12,5 / .5	0,001 / .00005	0,005	0,5 - 0,9	51	0,07	1303 102
12,5 / .5	0,01 / .0005	0,02	0,5 - 0,9	65	0,07	1303 201ip
12,5 / .5	0,001 / .00005	0,005	0,5 - 0,9	65	0,07	1303 202ip
Datenkabel RS232 (2m) / Data cable RS232 (2m)						1850 206
Datenkabel USB (2m) / Data cable USB (2m)						1850 208



No. 1303 101 / 1303 201ip  
No. 1303 102 / 1303 202ip

## Digital-Messuhren STANDARD Digital dial indicators, STANDARD



- ▶ Werksnorm
- ▶ großes LCD-Display
- ▶ Aluminiumgehäuse Ø 58mm
- ▶ Einspannschaft Ø 8mm h6
- ▶ Messeinsatz M2,5 auswechselbar
- ▶ Lieferung in Etui

### Funktionen:

- ▶ Ein/Aus
- ▶ mm/inch Umschaltung
- ▶ 0-Punkt an jeder Position
- ▶ Toleranzvorwahl
- ▶ ABS / Relativ Modus

- ▶ Works standard
- ▶ Large LCD display
- ▶ Aluminium housing Ø 58mm
- ▶ Clamping shaft Ø 8mm h6
- ▶ Interchangeable measuring insert M2.5
- ▶ Delivered in a case

### Functions:

- ▶ On/Off
- ▶ mm/inch commutation
- ▶ Zero setting at any position
- ▶ Tolerance pre-selection
- ▶ ABS / Relative mode

mm / inch	mm / inch	Fehler / Error max mm	kg	Nº
12,5 / .5	0,01 / .0005	0,03	0,2	1301 101s
25 / 1	0,01 / .0005	0,03	0,3	1301 102s
50 / 2	0,01 / .0005	0,04	0,4	1301 103s



No. 1301 101s

**Feinzeiger MYCRO**

**Comparator gauges, MYCRO**



- ▶ DIN 879-1
- ▶ mit Freihub und Stoßschutz
- ▶ Metallgehäuse Ø 62mm
- ▶ Anschluss für Drahtabheber
- ▶ Toleranzmarken einstellbar
- ▶ Einspannschaft Ø 8mm h6
- ▶ Messeinsatz M2,5 auswechselbar
- ▶ Messkraft ca. 1,2N
- ▶ Lieferung im Etui

- ▶ DIN 879-1
- ▶ Shock proof with overrun
- ▶ Metal housing Ø 62mm
- ▶ Connection for cable lifter
- ▶ Adjustable tolerance marks
- ▶ Clamping shaft Ø 8mm h6
- ▶ Interchangeable measuring insert M2.5
- ▶ Measuring force approx. 1.2N
- ▶ Delivered in a case

**1308 1.. :**

Feinzeiger Standard

**1308 1.. :**

Comparator gauges standard

**1308 2.. :**

Feinzeiger mit kurzem Messbolzen

**1308 2.. :**

Comparator gauges with short plunger

**!** Ausführungen mit erhöhter oder reduzierter Messkraft, Sonderzifferblätter, größere Schaftlängen sowie wassergeschützte Ausführung auf Anfrage.

**!** Versions with increased or reduced measuring force, special dials, larger shaft lengths and water-proof models on request.

$\frac{1}{100}$ mm	$\Delta \leq$ mm		$\bar{m}$ kg	Nº	Nº
0,5	0,01	25 - 0 - 25	0,3	<b>1308 101</b>	<b>1308 201</b>
0,1	0,001	50 - 0 - 50	0,3	<b>1308 102</b>	<b>1308 202</b>

Drahtabheber / Cable lifter

**1311 102**



Feineinstellung  
Fine adjustment



No. 1308 101

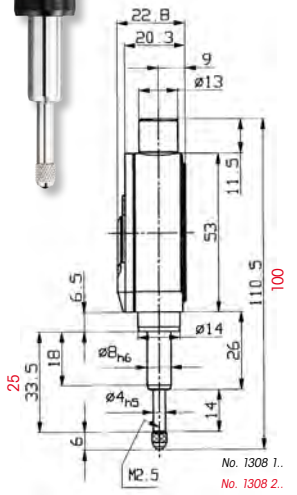

No. 1308 1..  
No. 1308 2..

**Feinzeiger MYTAST**

**Comparator gauges, MYTAST**



- ▶ DIN 879-1
- ▶ Schutzart IP (siehe Tabelle)
- ▶ mit Freihub und Stoßschutz
- ▶ Metallgehäuse Ø 62mm
- ▶ Anschluss für Drahtabheber
- ▶ Toleranzmarken einstellbar
- ▶ Einspannschaft Ø 8 h6
- ▶ Messeinsatz M2,5 auswechselbar
- ▶ Messkraft ca. 1N
- ▶ Lieferung im Etui

- ▶ DIN 879-1
- ▶ Protection class IP (see table)
- ▶ Shock proof with overrun
- ▶ Metal housing Ø 62mm
- ▶ Connection for cable lifter
- ▶ Adjustable tolerance marks
- ▶ Clamping shaft Ø 8mm h6
- ▶ Interchangeable measuring insert M2.5
- ▶ Measuring force approx. 1N
- ▶ Delivered in a case

**1308 501 :**

Feinzeiger Standard

**1308 501 :**

Comparator gauges standard

**1308 601 :**

Feinzeiger Schutzart IP 54

**1308 601 :**

Comparator gauges protection class IP 54

**!** Ausführungen mit erhöhter oder reduzierter Messkraft sowie Zoll-Ausführung auf Anfrage.

**!** Versions with increased or reduced measuring force and inch reading on request.

$\frac{1}{100}$ mm	$\Delta \leq$ mm		IP	$\bar{m}$ kg	Nº
0,1	0,001	50 - 0 - 50	-	0,3	<b>1308 501</b>
0,1	0,001	50 - 0 - 50	54	0,3	<b>1308 601</b>

Drahtabheber / Cable lifter

**1311 101**

Feineinstellung  
Fine adjustment



No. 1308 501

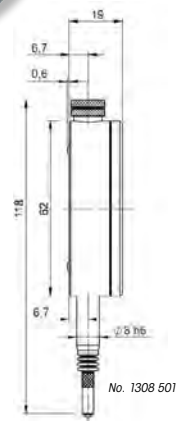

No. 1308 501

## Messuhren mit Feinzeigermesswerk

## Comparator gauges with precision movement



- ▶ Werksnorm, sehr hohe Genauigkeit
- ▶ Abmessung nach DIN EN ISO 463
- ▶ mit Freihub und Stoßschutz
- ▶ Gehäuse und Außenring aus Metall
- ▶ Toleranzmarken einstellbar
- ▶ Einspannschaft  $\varnothing$  8mm h6
- ▶ Messeinsatz M2,5 auswechselbar
- ▶ Lieferung im Etui

- ▶ Works standard, very high accuracy
- ▶ Dimensions acc. DIN EN ISO 463
- ▶ Shock proof with overrun
- ▶ Metal housing and outer ring
- ▶ Adjustable tolerance marks
- ▶ Clamping shaft  $\varnothing$  8 mm h6
- ▶ Interchangeable measuring insert M2.5
- ▶ Delivered in a case

**1310 101 – 1310 102 :**  
Feinzeigermessuhr Standard

**1310 101 – 1310 102 :**  
Comparator gauges standard

**1310 103 – 1310 105 :**  
Sicherheitsmessuhr  
1 Zeigerumdrehung = gesamter Messweg

**1310 103 – 1310 105 :**  
Safety dial gauge  
1 pointer rotation = total measuring range

! Sonderzifferblätter sowie wassergeschützte Ausführung auf Anfrage. ! Special dials and water-proof models on request.

mm	$\leq$ mm		Freihub / Overrun mm	$\varnothing$ mm	$\varnothing$ mm	kg	Nº
1,0	0,001	0 – 100	2,5	40	0,1	0,19	1310 101
1,0	0,001	0 – 100	4,0	58	0,1	0,3	1310 102
0,08	0,001	45 – 0 – 45	3,5	40	0,1	0,19	1310 103
0,08	0,001	45 – 0 – 45	5,0	58	0,1	0,3	1310 104
0,16	0,001	90 – 0 – 90	5,0	58	0,2	0,3	1310 105

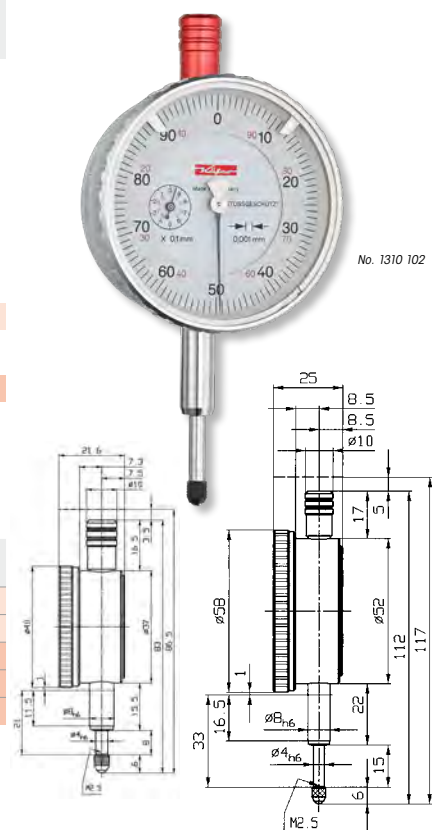

## Klein-Messuhren

## Dial gauges, small



- ▶ Werksnorm
- ▶ Abmessung nach DIN EN ISO 463
- ▶ Metallgehäuse
- ▶ Toleranzmarken einstellbar (nicht Abl. 0,1mm)
- ▶ Einspannschaft  $\varnothing$  8mm h6
- ▶ Messeinsatz M2,5 auswechselbar
- ▶ Lieferung im Etui

- ▶ Works standard
- ▶ Dimensions acc. DIN EN ISO 463
- ▶ Metal housing
- ▶ Adjustable tolerance marks (not 0.1mm reading)
- ▶ Clamping shaft  $\varnothing$  8mm h6
- ▶ Interchangeable measuring insert M2.5
- ▶ Delivered in a case

mm	$\leq$ mm	$\varnothing$ mm	Stoßschutz Shock proof	$\varnothing$ mm	kg	Nº
1	0,001	40	ohne / without	0,2	0,1	1321 104
1	0,001	40	mit / with	0,2	0,1	1321 107
10	0,1	40	ohne / without	10	0,1	1321 110
5	0,001	40	ohne / without	0,2	0,11	1321 108x
5	0,001	40	mit / with	0,2	0,11	1321 109x





## Messuhren DIN 878

## Dial gauges DIN 878



- ▶ DIN 878
- ▶ Abmessung nach DIN EN ISO 463
- ▶ Gehäuse Ø 58mm
- ▶ Toleranzmarken einstellbar
- ▶ Einspannschaft Ø 8mm h6
- ▶ Messeinsatz M2,5 auswechselbar
- ▶ Lieferung im Etui

- ▶ DIN 878
- ▶ Dimensions acc. DIN EN ISO 463
- ▶ Housing Ø 58 mm
- ▶ Adjustable tolerance marks
- ▶ Clamping shaft Ø 8 mm h6
- ▶ Interchangeable measuring insert M2.5
- ▶ Delivered in a case

**1320 101 – 1320 102 :**  
Metallgehäuse, Außenring Polyamid

**1320 101 – 1320 102 :**  
Metal housing, outer ring polyamide

**1320 101m – 1320 102m :**  
Gehäuse und Außenring aus Metall

**1320 101m – 1320 102m :**  
Metal housing and outer ring

**1320 103 :**  
Metallgehäuse, Außenring Polyamid  
mit 2 konzentrischen Zeigern

**1320 103 :**  
Metal housing, outer ring polyamide  
with 2 concentric pointers

**1320 104 – 1320 105 :**  
Gehäuse und Außenring aus Polyamid

**1320 104 – 1320 105 :**  
Polyamide housing and outer ring

**!** Ausführungen mit erhöhter oder reduzierter Messkraft, Sonderzifferblätter, größere Schaftlängen sowie Modelle mit Feststellschraube oder Abhebevorrichtung auf Anfrage.

**!** Versions with increased or reduced measuring force, special dials, larger shaft lengths and models with locking screw or lifting device on request.

mm	<math>\Delta</math> mm	Stoßschutz Shock proof	mm	kg	Nº	Nº
Metallgehäuse / Metal housing						
10	0,01	ohne / without	1	0,3	1320 101	1320 101m
10	0,01	mit / with	1	0,3	1320 102	1320 102m
10	0,01	ohne / without	1	0,3	1320 103	-
Gehäuse aus Polyamid / Polyamide housing						
10	0,01	ohne / without	1	0,2	1320 104	-
10	0,01	mit / with	1	0,2	1320 105	-



## Klein-Messuhren

## Dial gauges, small



- ▶ DIN 878
- ▶ Abmessung nach DIN EN ISO 463
- ▶ Toleranzmarken einstellbar
- ▶ Einspannschaft Ø 8mm h6
- ▶ Messeinsatz M2,5 auswechselbar
- ▶ Lieferung im Etui

- ▶ DIN 878
- ▶ Dimensions acc. DIN EN ISO 463
- ▶ Adjustable tolerance marks
- ▶ Clamping shaft Ø 8 mm h6
- ▶ Interchangeable measuring insert M2.5
- ▶ Delivered in a case

**!** Ausführungen mit erhöhter oder reduzierter Messkraft, Sonderzifferblätter, größere Schaftlängen sowie Modelle mit Feststellschraube oder Abhebevorrichtung auf Anfrage.

**!** Versions with increased or reduced measuring force, special dials, larger shaft lengths and models with locking screw or lifting device on request.

mm	<math>\Delta</math> mm	Ø mm	Stoßschutz Shock proof	mm	kg	Nº
Metallgehäuse / Metal housing						
3	0,01	32	ohne / without	0,5	0,18	1321 101
3	0,01	40	ohne / without	0,5	0,1	1321 102
5	0,01	40	ohne / without	0,5	0,1	1321 103
3	0,01	40	mit / with	0,5	0,1	1321 105
5	0,01	40	mit / with	0,5	0,1	1321 106
5	0,01	40	ohne / without	1	0,1	1321 111
10	0,01	40	ohne / without	1	0,1	1321 112
Polyamidgehäuse / Polyamide housing						
5	0,01	40	ohne / without	0,5	0,08	1321 109

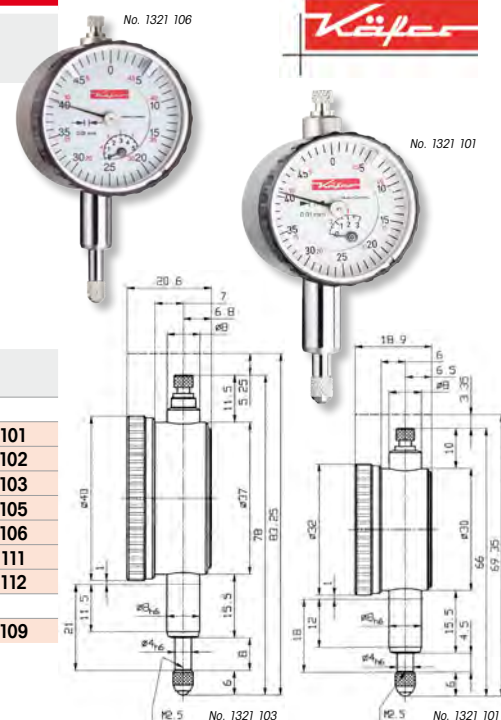

## Messuhren Zoll-System

## Dial gauges with inch system



- ▶ Werksnorm
- ▶ Abmessung nach DIN EN ISO 463
- ▶ Metallgehäuse
- ▶ Toleranzmarken einstellbar
- ▶ Einspannschaft Ø 8mm h6
- ▶ Messeinsatz M2,5 auswechselbar
- ▶ Lieferung im Etui

1 Ausführungen nach ANSI, wasserdichte Zollmessuhren sowie Modelle mit rückwärtigem Messbolzen auf Anfrage.

- ▶ Works standard
- ▶ Dimensions acc. DIN EN ISO 463
- ▶ Metal housing
- ▶ Adjustable tolerance marks
- ▶ Clamping shaft Ø 8mm h6
- ▶ Interchangeable measuring insert M2.5
- ▶ Delivered in a case

1 Versions according to ANSI, water-proof inch dial gauges and models with back plungers on request.

mm inch	Δε inch	Ø inch	ϕ inch	kg	Nº
.12	.001	1 9/16	.02	0,2	1322 130
.5	.0005	2 1/4	.05	0,3	1322 131
.2	.0001	2 1/4	.01	0,3	1322 132
1	.0005	2 1/4	.05	0,35	1322 133

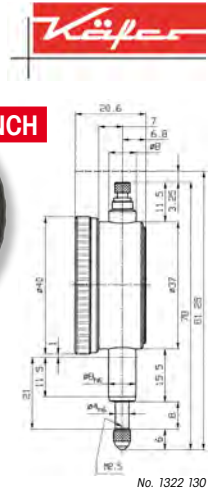

## Messuhren BASIC

## Dial gauges BASIC



- ▶ Metallgehäuse Ø 58mm
- ▶ Toleranzmarken einstellbar
- ▶ Einspannschaft Ø 8mm h6
- ▶ Verstärkter Tastbolzen Ø 5mm
- ▶ Messeinsatz M2,5 auswechselbar
- ▶ Lieferung im Etui

1318 101 / 1318 102 :  
DIN 878

1318 103 / 1318 104 :  
Werksnorm

- ▶ Metal housing Ø 58mm
- ▶ Adjustable tolerance marks
- ▶ Clamping shaft Ø 8mm h6
- ▶ reinforced probe shaft Ø 5mm
- ▶ Interchangeable measuring inserts M2.5
- ▶ Delivered in a case

1318 101 / 1318 102 :  
DIN 878

1318 103 / 1318 104 :  
Works standard

mm	Δε mm	Stoßschutz Shock proof	ϕ mm	kg	Nº
10	0,01	ohne / without	1	0,3	1318 101
10	0,01	mit / with	1	0,3	1318 102
30	0,01	ohne / without	1	0,4	1318 103
30	0,01	mit / with	1	0,4	1318 104



No. 1318 104



No. 1318 101

## Messuhren STANDARD

## Dial gauges STANDARD



- ▶ Metallgehäuse Ø 58mm
- ▶ Toleranzmarken einstellbar
- ▶ Einspannschaft Ø 8mm h6
- ▶ Messeinsatz M2,5 auswechselbar
- ▶ Lieferung im Etui

5040 103 / 5041 103 :  
DIN 878

5040 104 / 5041 104 :  
Werksnorm

- ▶ Metal housing Ø 58mm
- ▶ Adjustable tolerance marks
- ▶ Clamping shaft Ø 8mm h6
- ▶ Interchangeable measuring insert M2.5
- ▶ Delivered in a case

5040 103 / 5041 103 :  
DIN 878

5040 104 / 5041 104 :  
Works standard

mm	Δε mm	ϕ mm	kg	Nº
10	0,01	1	0,3	5040 103
30	0,01	1	0,4	5040 104



No. 5040 104



No. 5040 103

**Messuhren Schutzart IP67**

**Dial gauges Protection class IP67**



- ▶ Stoßschutz, wasser- und öldicht
- ▶ Gehäuse und Außenring aus Metall
- ▶ Toleranzmarken einstellbar
- ▶ Einspannschaft Ø 8mm h6
- ▶ Messeinsatz M2,5 auswechselbar
- ▶ Lieferung im Etui

- ▶ Shockproof, water- and oilproof
- ▶ Metal housing and outer ring
- ▶ Adjustable tolerance marks
- ▶ Clamping shaft Ø 8mm h6
- ▶ Interchangeable measuring insert M2.5
- ▶ Delivered in a case

**1324 101 – 1324 102 :**  
DIN 878

**1324 101 – 1324 102 :**  
DIN 878

**1324 103 – 1324 104 :**  
Werknorm

**1324 103 – 1324 104 :**  
Works standard

! Ausführungen mit erhöhter oder reduzierter Messkraft, Sonderzifferblätter, größere Schaftlängen auf Anfrage.

! Versions with increased or reduced measuring force, special dials and larger shaft lengths on request.

mm	≤ mm	Ø mm	mm	kg	Nº
3	0,01	44,5	0,5	0,2	1324 101
10	0,01	61,5	1	0,35	1324 102
1	0,002	44,5	0,2	0,2	1324 103
1	0,001	61,5	0,2	0,35	1324 104



No. 1324 102

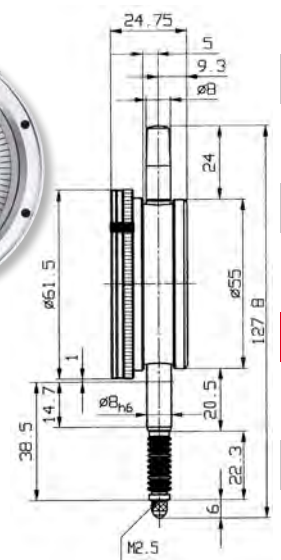

**Messuhren Sicherheitsausführung**

**Dial gauges safety model**



- ▶ DIN 878
- ▶ 1 Zeigerumdrehung = gesamter Messweg
- ▶ mit Freihub und Stoßschutz
- ▶ Metallgehäuse
- ▶ Toleranzmarken einstellbar
- ▶ Einspannschaft Ø 8mm h6
- ▶ Messeinsatz M2,5 auswechselbar
- ▶ Lieferung im Etui

- ▶ DIN 878
- ▶ 1 pointer rotation = total measuring range
- ▶ Shock proof with overrun
- ▶ Metal housing
- ▶ Adjustable tolerance marks
- ▶ Clamping shaft Ø 8mm h6
- ▶ Interchangeable measuring insert M2.5
- ▶ Delivered in a case

**1322 1.. :**  
Messuhren, Abmessung nach DIN EN ISO 463

**1322 1.. :**  
Dial gauges, dimensions acc. DIN EN ISO 463

**1322 2.. :**  
Messuhren Schutzart IP67

**1322 2.. :**  
Dial gauges protection class IP67

! Ausführungen mit erhöhter oder reduzierter Messkraft, Sonderzifferblätter, größere Schaftlängen sowie Modelle mit Feststellschraube oder Abhebevorrichtung auf Anfrage.

! Versions with increased or reduced measuring force, special dials, larger shaft lengths and models with locking screw or lifting device on request.

mm	≤ mm	mm	Freihub / Overrun mm	Ø mm	kg	Nº	Ø mm	kg	Nº
0,4	0,01	20 - 0 - 20	4,5	40	0,2	1322 140	44,5	0,25	1322 240
0,8	0,01	40 - 0 - 40	9	58	0,3	1322 128	61,5	0,35	1322 228
1,0	0,01	50 - 0 - 50	9	58	0,3	1322 142	61,5	0,35	1322 242



No. 1322 228



No. 1322 140

## Messuhren

## Dial gauges



- ▶ Werksnorm
- ▶ Abmessung nach DIN EN ISO 463
- ▶ Metallgehäuse Ø 58mm
- ▶ Toleranzmarken einstellbar (nicht Abl. 0,1mm)
- ▶ Einspannschaft Ø 8mm h6
- ▶ Messeinsatz M2,5 auswechselbar
- ▶ Lieferung im Etui

- ▶ Works standard
- ▶ Dimensions acc. DIN EN ISO 463
- ▶ Metal housing Ø 58mm
- ▶ Adjustable tolerance marks (no 0.1mm reading)
- ▶ Clamping shaft Ø8 mm h6
- ▶ Interchangeable measuring insert M2.5
- ▶ Delivered in a case

! Ausführungen mit erhöhter oder reduzierter Messkraft, Sonderzifferblätter, sowie größere Schaftlängen auf Anfrage.

! Versions with increased or reduced measuring force, special dials and larger shaft lengths are on request.

∅ mm	<math>\leq</math> mm	Stoßschutz Shock proof	∅ mm	∅ kg	Nº
10	0,1	ohne / without	10	0,2	1322 101
20	0,1	ohne / without	10	0,25	1322 102
30	0,1	ohne / without	10	0,25	1322 103
20	0,01	mit / with	1	0,25	1322 105
20	0,01	ohne / without	1	0,25	1322 106
30	0,01	mit / with	1	0,3	1322 121
30	0,01	ohne / without	1	0,3	1322 109
50	0,01	ohne / without	1	0,35	1322 110
80	0,01	ohne / without	1	0,45	1322 110x
1	0,001	mit / with	0,2	0,3	1322 123
5	0,001	mit / with	0,2	0,3	1322 124
1	0,001	ohne / without	0,2	0,3	1322 117
5	0,001	ohne / without	0,2	0,3	1322 118



No. 1322 109



No. 1322 124

## Groß-Messuhren

## Dial gauges, large



- ▶ Werksnorm (1322 111, 1322 122 nach DIN 878)
- ▶ Metallgehäuse
- ▶ Toleranzmarken einstellbar (nicht Abl. 0,1mm und Ø 100mm)
- ▶ Einspannschaft Ø 8mm h6 (außer Nr. 1322 114 = Ø 10mm h6)
- ▶ Messeinsatz M2,5 auswechselbar
- ▶ Lieferung im Etui

- ▶ Works standard (1322 111, 1322 122 acc. DIN 878)
- ▶ Metal housing
- ▶ Adjustable tolerance marks (no 0.1mm reading and Ø 100mm)
- ▶ Clamping shaft Ø 8mm h6 (except No. 1322 114 = Ø 10mm h6)
- ▶ Interchangeable measuring insert M2.5
- ▶ Delivered in a case

! Ausführung mit erhöhter oder reduzierter Messkraft, Sonderzifferblätter sowie größere Schaftlängen auf Anfrage.

! Versions with increased or reduced measuring force, special dials and larger shaft lengths on request.

∅ mm	<math>\leq</math> mm	∅ mm	Stoßschutz Shock proof	∅ mm	∅ kg	Nº
20	0,1	80	ohne / without	10	0,3	1322 104
10	0,01	80	mit / with	1	0,4	1322 122
10	0,01	80	ohne / without	1	0,4	1322 111
50	0,01	80	ohne / without	1	0,45	1322 113
100	0,01	80	ohne / without	1	0,5	1322 114
50	0,01	100	ohne / without	1	0,6	1322 115
5	0,001	80	mit / with	0,2	0,4	1322 125

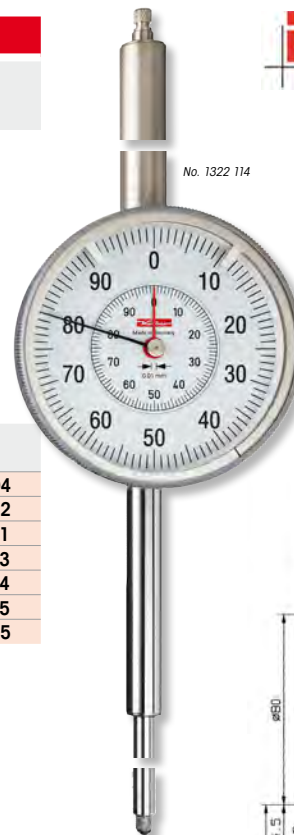

No. 1322 114

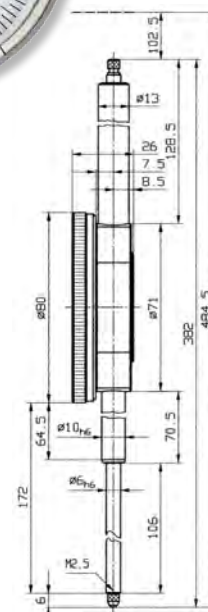

## Messuhren mit magnetischer Rückwand

## Dial gauges with magnetic back



- ▶ DIN 878
- ▶ Metallgehäuse
- ▶ Toleranzmarken einstellbar
- ▶ Einspannschaft Ø 8mm h6
- ▶ Messeinsatz M2,5 auswechselbar
- ▶ Lieferung im Etui

- ▶ DIN 878
- ▶ Metal housing
- ▶ Adjustable tolerance marks
- ▶ Clamping shaft Ø 8mm h6
- ▶ Interchangeable measuring insert M2.5
- ▶ Delivered in a case

! Ausführungen mit erhöhter oder reduzierter Messkraft, Sonderzifferblätter, sowie größere Schaftlängen auf Anfrage.

! Versions with increased or reduced measuring force, special dials and larger shaft lengths on request.

W mm	Δ mm	Ø mm	U mm	W kg	Nº
10	0,01	58	1,0	0,42	1325 101
3	0,01	40	0,5	0,25	1325 102



## Messuhren mit rückseitigem Taster

## Dial gauges with back plungers



- ▶ Werksnorm
- ▶ Abmessung nach DIN EN ISO 463
- ▶ Metallgehäuse
- ▶ Toleranzmarken einstellbar
- ▶ Einspannschaft Ø 8mm h6
- ▶ Messeinsatz M2,5, auswechselbar
- ▶ Lieferung im Etui

- ▶ Works standard
- ▶ Dimensions acc. DIN EN ISO 463
- ▶ Metal housing
- ▶ Adjustable tolerance marks
- ▶ Clamping shaft Ø 8mm h6
- ▶ Interchangeable measuring insert M2.5
- ▶ Delivered in a case

! Ausführungen mit erhöhter oder reduzierter Messkraft, Sonderzifferblätter sowie größere Schaftlängen auf Anfrage.

! Versions with increased or reduced measuring force, special dials and larger shaft lengths on request.

W mm	Δ mm	Ø mm	U mm	W kg	Nº
3	0,01	40	0,5	0,2	1326 101
3	0,01	58	1	0,35	1326 102
5	0,01	40	0,5	0,2	1326 104
5	0,01	58	1	0,35	1326 105

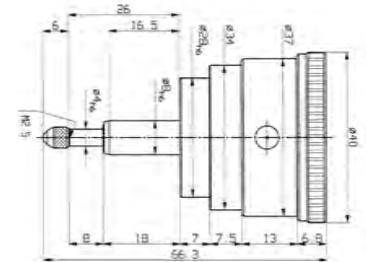

## Fühlhebel für Messuhren

## Test indicators (lever-type) for dial gauges



- ▶ zum Ausrichten von Bohrungen
- ▶ Messweg ca. 8mm
- ▶ Einspannschaft Ø 8mm h6
- ▶ Messuhraufnahme Ø 8mm
- ▶ Lieferung einzeln verpackt ohne Messuhr

- ▶ For alignment of bores
- ▶ Measuring range approx. 8mm
- ▶ Clamping shaft Ø 8mm h6
- ▶ Dial mounting hole Ø 8mm
- ▶ Delivered in individual packages without dial gauge

1345 101 :  
Innenfühlhebel

1345 101 :  
Inside-lever test indicators

1345 102 :  
Winkelfühlhebel

1345 102 :  
Angular-lever test indicators

W mm	min. Ø mm	W kg	Nº
60	6	0,2	1345 101
30	6	0,2	1345 102



## Messuhren Zubehör

## Dial gauge accessories



► Lieferung einzeln verpackt

► Delivered in individual packages

**1331 101 / 1332 101 / 1332 201 :**  
Für GehäuseØ 40mm

**1331 101 / 1332 101 / 1332 201 :**  
For housingØ 40mm

**1331 102 / 1332 102 / 1332 202 :**  
Für GehäuseØ 58mm

**1331 102 / 1332 102 / 1332 202 :**  
For housingØ 58mm

! Anderes Zubehör auf Anfrage.

! Other accessories on request.



No. 1331 1..

Typ Type	⚖ kg	Ø 40mm Nº	Ø 58mm Nº
Abhebevorrichtung / Lifting device	0,002	<b>1331 101</b>	<b>1331 102</b>
Rückendeckel mit Öse / Back cover with lug	0,01	<b>1332 101</b>	<b>1332 102</b>
Rückendeckel mit Magnet / Back cover with magnet	0,16	<b>1332 201</b>	<b>1332 202</b>
Reduzierhülse für Ø 3/8" auf Ø 8mm / Adapter for 3/8" to Ø 8mm	0,002	<b>1331 201</b>	

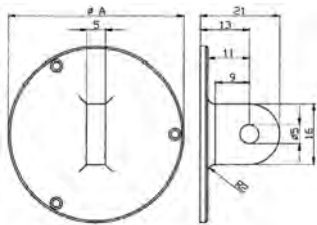

No. 1332 1..



No. 1332 2..

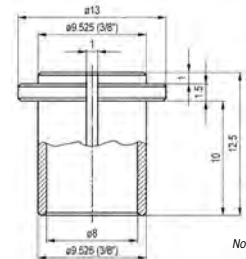

No. 1331 201

## Magnet-Halter

## Magnetic holder



► kräftiger Dauermagnet  
► Messuhraufnahme Ø 8mm  
► Lieferung einzeln verpackt, ohne Messuhr

► Sturdy permanent magnet  
► Dial mounting hole Ø 8mm  
► Delivered in individual packages, without dial gauge

**1336 101 :**  
Halter starr

**1336 101 :**  
Holder rigid

**1336 102 / 103 :**  
Halter mit schwenkbarem Querarm

**1336 102 / 103 :**  
Holder with movable arm

⊥ mm	≡ mm	⚖ Kp	Fuß / Base mm	⚖ kg	Nº
60	-	13	Ø 46 (flach / flat)	0,2	<b>1336 101</b>
46	35	18	73x38x11 (flach / flat)	0,3	<b>1336 102</b>
59	35	18	73x37x26 (Prisma / V base)	0,4	<b>1336 103</b>



No. 1336 101

No. 1336 102



No. 1336 103

## Tiefenmessbrücken

## Depth measuring bridges



- ▶ Messfläche gehärtet, DIN 876/0
- ▶ Messuhraufnahme Ø 8mm
- ▶ Lieferung einzeln verpackt

- ▶ Hardened measuring faces DIN 876/0
- ▶ Dial mounting hole Ø 8mm
- ▶ Delivered in individual packages



No. 1370 205

mm	kg	Nº
50x16	0,18	1370 201
80x16	0,2	1370 202
100x16	0,23	1370 204

mm	kg	Nº
120x20	0,25	1370 203
150x20	0,3	1370 205



No. 1370 202

## Tastbolzenverlängerungen für Messuhren und Feinzeiger

## Probe extensions for dial gauges and comparator gauges



- ▶ Anschlussgewinde M2,5
- ▶ Lieferung einzeln verpackt

- ▶ Mounting thread M2.5
- ▶ Delivered in individual packages

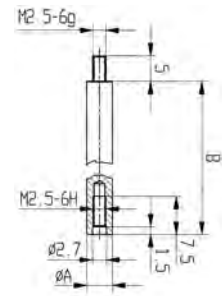

1330 1.. :  
Ø 4mm

1330 1.. :  
Ø 4mm

1330 2.. :  
Ø 5mm

1330 2.. :  
Ø 5mm

B l- l mm	A Ø 4 mm Nº	A Ø 5 mm Nº
10	1330 120	1330 220
15	1330 121	1330 221
20	1330 122	1330 222
25	1330 123	1330 223
30	1330 124	1330 224
35	1330 125	1330 225
40	1330 126	1330 226

B l- l mm	A Ø 4 mm Nº	A Ø 5 mm Nº
45	1330 127	1330 227
50	1330 128	1330 228
55	1330 129	1330 229
60	1330 130	1330 230
65	1330 131	1330 231
70	1330 132	1330 232
75	1330 133	1330 233

B l- l mm	A Ø 4 mm Nº	A Ø 5 mm Nº
80	1330 134	1330 234
85	1330 135	1330 235
90	1330 136	1330 236
95	1330 137	1330 237
100	1330 138	1330 238

## Adapter für Messuhren und Feinzeiger

## Adapter for dial gauges and comparator gauges



- ▶ Spezialstahl
- ▶ Anschlussgewinde M2,5
- ▶ Innengewinde 4/48 NF
- ▶ Lieferung einzeln verpackt

- ▶ Special steel
- ▶ Mounting thread M2.5
- ▶ Internal thread 4/48 NF
- ▶ Delivered in individual packages

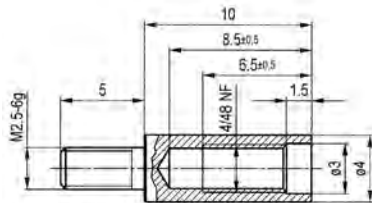

Nº

1330 701

**Messeinsätze – M2,5**  
**Spezialstahl gehärtet oder Hartmetall**

**Measuring inserts – M2.5**  
**Hardened special steel or tungsten carbide**



- Für Messuhren und Feinzeiger
- Anschlussgewinde M2,5
- Lieferung einzeln verpackt

- For dial gauges and comparator gauges
- Mounting thread M2.5
- Delivered in individual packages

**Bestellhinweis:**

Für Taster mit Durchmesser- und Längenvarianten bitte gewünschtes Nennmaß angeben.  
 Beispiel: Tasterausführung 1330 103-D in Ø 19mm  
 = Nr. 1330 103-19

**Order advice:**

For probes with diameter- and length versions please mention the required nominal size.  
 Example: Probe type 1330 103-D with Ø 19mm  
 = No. 1330 103-19

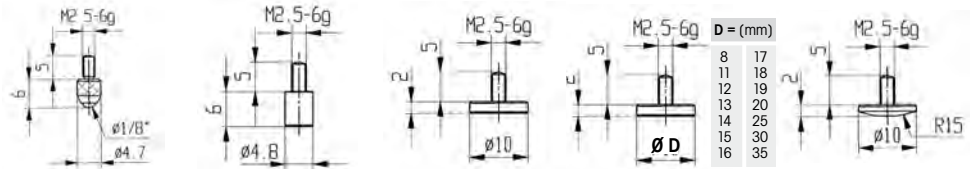

Tasterausführung / Probe type	Nº	Nº	Nº	Nº	Nº
Spezialstahl / Special steel	1330 101	1330 102	1330 103	1330 103-D	1330 104
Hartmetall / Tungsten carbide	1330 201	1330 202	1330 203	-	1330 204

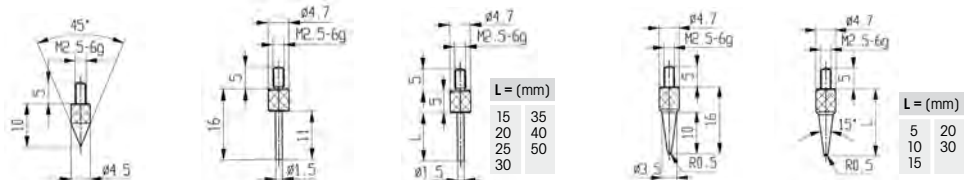

Tasterausführung / Probe type	Nº	Nº	Nº	Nº	Nº
Spezialstahl / Special steel	1330 105	1330 106	1330 106-L	1330 107	1330 107-L
Hartmetall / Tungsten carbide	1330 205	1330 206	-	-	-

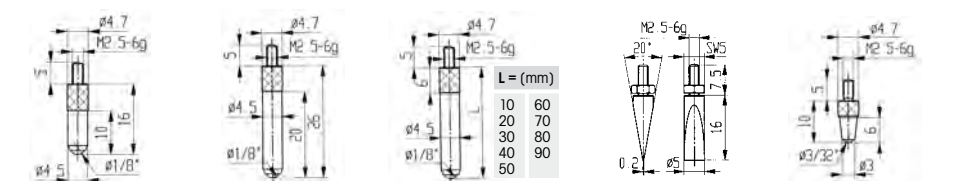

Tasterausführung / Probe type	Nº	Nº	Nº	Nº	Nº
Spezialstahl / Special steel	1330 108	1330 109	1330 109-L	1330 112	1330 113
Hartmetall / Tungsten carbide	1330 208	1330 209	-	1330 212	1330 213

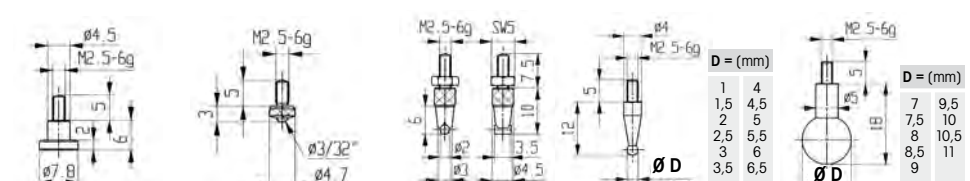

Tasterausführung / Probe type	Nº	Nº	Nº	Nº	Nº
Spezialstahl / Special steel	1330 114	1330 115	1330 116	1330 110-D	1330 111-D
Hartmetall / Tungsten carbide	-	1330 215	1330 216	1330 210-D	-

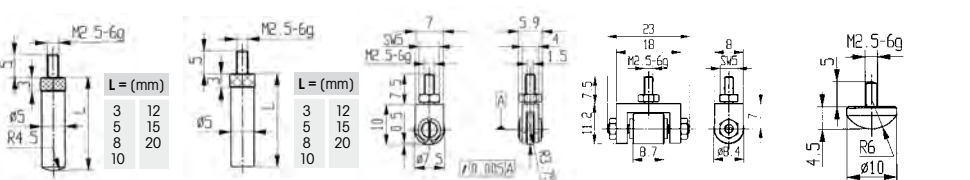

Tasterausführung / Probe type	Nº	Nº	Nº	Nº	Nº
Spezialstahl / Special steel	1330 118-D	1330 119-D	1330 601	1330 602	1330 150

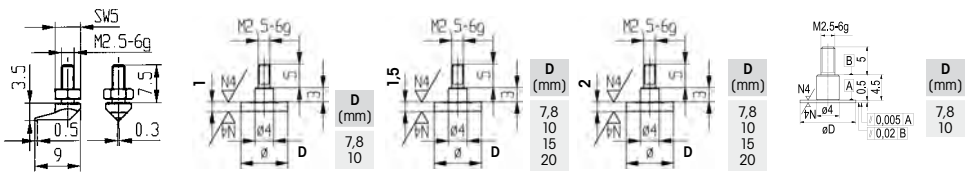

Tasterausführung / Probe type	Nº	Nº	Nº	Nº	Nº
Spezialstahl / Special steel	1330 151	1330 160-D	1330 161-D	1330 162-D	1330 163-D



**Messeinsätze – M2,5  
Rubin, Saphir oder Keramik**

**Measuring inserts – M2.5  
Ruby, sapphire or ceramic**



- Für Messuhren und Feinzeiger
- Anschlussgewinde M2,5
- Lieferung einzeln verpackt

- For dial gauges and comparator gauges
- Mounting thread M2.5
- Delivered in individual packages

**Bestellhinweis:**

Für Taster mit Durchmesservarianten bitte gewünschtes Nennmaß angeben.  
Beispiel: Tasterausführung 1330 310-D in Ø 4mm  
= Nr. 1330 310-4

**Order advice:**

For probes with diameter versions please mention the required nominal size.  
Example: Probe type 1330 310-D with Ø 4mm  
= No. 1330 310-4

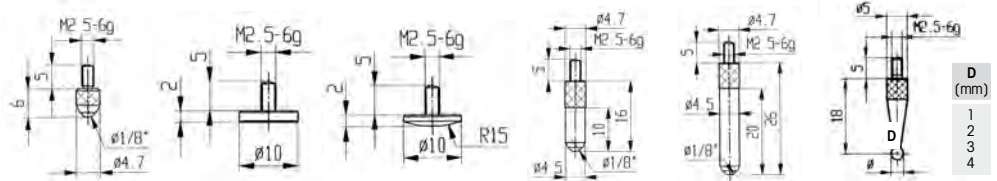

Tasterausführung / Probe type	Nº	Nº	Nº	Nº	Nº	Nº
Rubineinsatz / Ruby insert	1330 301	-	-	1330 308	1330 309	1330 310-D
Saphireinsatz / Sapphire insert	1330 401	-	-	1330 408	1330 409	-
Keramikersatz / Ceramic insert	1330 501	1330 503	1330 504	-	-	-

**System Messeinsätze  
für Messuhren und Feinzeiger**

**System measuring inserts  
for dial gauges and comparator gauges**



Diese Messeinsätze haben Innengewinde (M2,5 und/ oder M1,6) und können mit anderen Messeinsätzen kombiniert werden.

These measuring inserts have internal thread (M2.5 and/or M1.6) to combine them with other inserts.

- Spezialstahl
- Anschlussgewinde M2,5
- Lieferung einzeln verpackt

- Special steel
- Mounting thread M2.5
- Delivered in individual packages

! Andere Ausführungen, Sondertaster nach Zeichnung auf Anfrage.

! Other versions and special probes as per specifications on request.

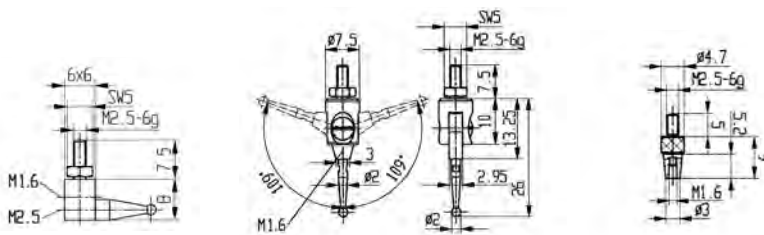

Nº	Nº	Nº
1330 117	1330 611	1330 612

## Digital-Fühlhebelmessgeräte Schutzart IP65

## Digital dial test indicators (Lever type) Protection class IP65



- ▶ Werksnorm
- ▶ LCD-Display, analog/digital, drehbar 360°
- ▶ Wiederholbarkeit 0,001mm
- ▶ Außenring Ø 44mm
- ▶ Einspannschaft Ø 8mm h6
- ▶ Schwalbenschwanzführung 3-fach
- ▶ Messstaster 270° schwenkbar, Hartmetallkugel Ø 2mm, M 1,4
- ▶ Lieferung im Kartonbox

### Funktionen:

- ▶ Ein/Aus
- ▶ mm/inch Umschaltung
- ▶ 0-Punkt an jeder Position
- ▶ Auto OFF
- ▶ Ablesung umschaltbar 0,01 / 0,001mm
- ▶ ± Preset Funktion ≤ 130
- ▶ MIN / MAX Wertspeicher
- ▶ Datenausgang

- ▶ Works standard
- ▶ LCD display, analogue/digital, turnable 360°
- ▶ Repeatability 0.001 mm
- ▶ Outer ring Ø 44mm
- ▶ Clamping shaft Ø 8mm h6
- ▶ Dovetail slide x 3
- ▶ Probe swivelling through 270°, carbide ball Ø 2mm, M 1.4
- ▶ Delivered in a cardboard box

### Funktionen:

- ▶ On/Off
- ▶ mm/inch commutation
- ▶ Zero setting at any position
- ▶ Auto OFF
- ▶ Reversible reading 0.01 / 0.001mm
- ▶ ± Preset function ≤ 130
- ▶ Min. / Max. value memory
- ▶ Data output



No. 1339 501

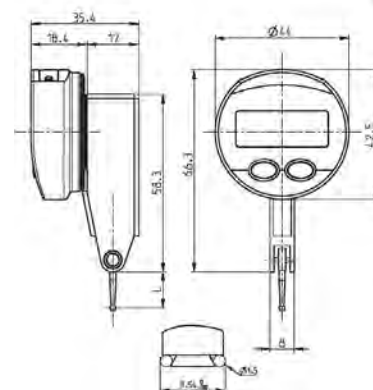

mm / inch	mm / inch	fe / fw mm	N	L mm	kg	Nº
0,8 / .03	0,01 / .0005 0,001 / .00005	0,01 / 0,003	0,13 ±15%	12,5	0,07	1339 501
0,5 / .02	0,01 / .0005 0,001 / .00005	0,01 / 0,003	0,07 ±15%	36,5	0,07	1339 502
Datenkabel / Data cable RS232 (2m)						1850 206
Datenkabel / Data cable USB (2m)						1850 208

## Messeinsätze für Digital-Fühlhebelmessgeräte

## Measuring inserts for digital dial test indicators



- ▶ Anschlussgewinde M1,4
- ▶ Lieferung einzeln verpackt

- ▶ Mounting thread M1.4
- ▶ Delivered in individual packages

1346 1.. :

Hartmetall

1346 1.. :

Tungsten carbide

1346 2.. :

Rubin

1346 2.. :

Ruby

Kugel / Ball Ø mm	mm	g	Nº	Nº
1	12	1	1346 101	1346 201
2	12	1	1346 102	1346 202
3	12	1	1346 103	1346 203
1	36	1	1346 104	1346 204
2	36	1	1346 105	1346 205
3	36	1	1346 106	1346 206



No. 1346 101



No. 1346 102



No. 1346 103



No. 1346 104



No. 1346 105



No. 1346 106

## Fühlhebelmessgeräte

## Dial test indicators (lever type)



- ▶ DIN 2270
- ▶ Metallgehäuse
- ▶ Außenring drehbar
- ▶ Anzeige antimagnetisch
- ▶ Messwerk in Lochsteinen aus Keramik, Rubin oder Saphir gelagert
- ▶ Schwalbenschwanzführung 3-fach
- ▶ Messtaster 240° schwenkbar, Hartmetallkugel Ø 2mm, M1,6
- ▶ Lieferung im Etui, inkl. Einspannschaft Ø 8mm und Schlüssel

- ▶ DIN 2270
- ▶ Metal housing
- ▶ Turnable outer ring
- ▶ Anti-magnetic indicator
- ▶ Precision movement in ceramic, ruby or sapphire bearings
- ▶ Dovetail slide x3
- ▶ Probe swivelling through 240°, carbide ball Ø 2mm, M1.6
- ▶ Delivered in a case incl. clamping shaft Ø 8mm and spanner

1340 1.. / 1341 1.. / 1342 1.. :

Fühlhebelmessgeräte Standard

1340 1.. / 1341 1.. / 1342 1.. :

Dial test indicators standard

1340 2.. :

Fühlhebelmessgeräte Schutzart IP54

1340 2.. :

Dial test indicators Protection class IP54

mm	mm		mm	L mm	kg	Nº	Nº
Bauform nach DIN 2270 A / Model according to DIN 2270 A							
1,0	0,01	0 - 50 - 0	40	16,6	0,2	1340 100	-
0,8	0,01	0 - 40 - 0	32	12,8	0,2	1340 101	-
0,8	0,01	0 - 40 - 0	40	12,8	0,2	1340 102	1340 202
0,5	0,01	0 - 25 - 0	32	35,7	0,2	1340 103	-
0,5	0,01	0 - 25 - 0	40	35,7	0,2	1340 104	1340 204
0,2	0,002	0 - 100 - 0	32	12,8	0,2	1340 105	-
0,2	0,002	0 - 100 - 0	40	12,8	0,2	1340 106	1340 206
Bauform nach DIN 2270 B / Model according to DIN 2270 B							
0,8	0,01	0 - 40 - 0	32	12,8	0,2	1341 101	-
0,8	0,01	0 - 40 - 0	40	12,8	0,2	1341 102	-
0,5	0,01	0 - 25 - 0	32	35,7	0,2	1341 103	-
0,5	0,01	0 - 25 - 0	40	35,7	0,2	1341 104	-
0,2	0,002	0 - 100 - 0	32	12,8	0,2	1341 105	-
0,2	0,002	0 - 100 - 0	40	12,8	0,2	1341 106	-
Bauform nach DIN 2270 C / Model according to DIN 2270 C							
0,8	0,01	0 - 40 - 0	32	12,8	0,2	1342 101	-
0,8	0,01	0 - 40 - 0	40	12,8	0,2	1342 102	-
0,5	0,01	0 - 25 - 0	32	35,7	0,2	1342 103	-
0,5	0,01	0 - 25 - 0	40	35,7	0,2	1342 104	-
0,2	0,002	0 - 100 - 0	32	12,8	0,2	1342 105	-
0,2	0,002	0 - 100 - 0	40	12,8	0,2	1342 106	-



DIN 2270 A

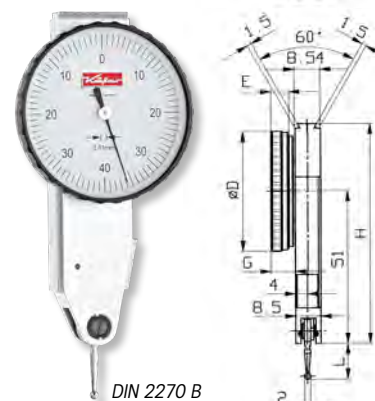

DIN 2270 B

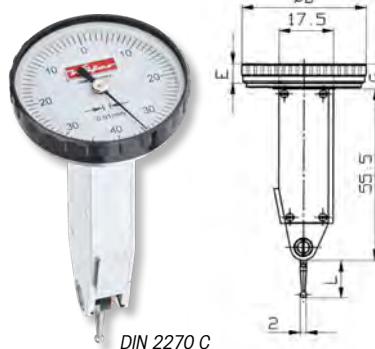

DIN 2270 C

## Fühlhebelmessgeräte STANDARD

## Dial test indicators (lever type) STANDARD



- ▶ Werksnorm
- ▶ Metallgehäuse
- ▶ Außenring drehbar
- ▶ Anzeige antimagnetisch
- ▶ Schwalbenschwanzführung 2-fach
- ▶ Messtaster 240° schwenkbar, Spezialstahl, Kugel Ø 2mm
- ▶ Tasterlänge 13mm
- ▶ Lieferung im Etui, inkl. Einspannschaft Ø 8mm und Schlüssel

- ▶ Works standard
- ▶ Metal housing
- ▶ Turnable outer ring
- ▶ Anti-magnetic indicator
- ▶ Dovetail slide x2
- ▶ Probe swivelling through 240°, special steel, ball Ø 2mm
- ▶ Probe length 13mm
- ▶ Delivered in a case incl. clamping shaft Ø 8mm and spanner

mm	mm		mm	kg	Nº
0,8	0,01	0 - 40 - 0	32	0,2	1340 101s
0,2	0,002	0 - 40 - 0	40	0,2	1340 106s
Messeinsatz Ø 1x13mm / Measuring insert Ø 1x13mm					1343 105s
Messeinsatz Ø 2x13mm / Measuring insert Ø 2x13mm					1343 104s



No. 1340 101s

## Einspannschäfte für Fühlhebelmessgeräte

## Clamping shafts for dial test indicators



- ▶ Schwalbenschwanzklemmung
- ▶ Lieferung einzeln verpackt

- ▶ Dovetail clamping
- ▶ Delivered in individual packages

Ø mm	kg	Nº
8 h6	0,005	1343 100
4 h6	0,005	1343 102
8 h6	0,005	1343 103

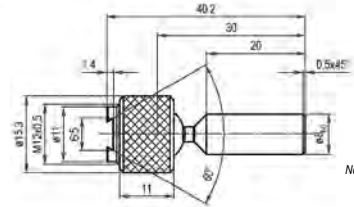

No. 1343 100

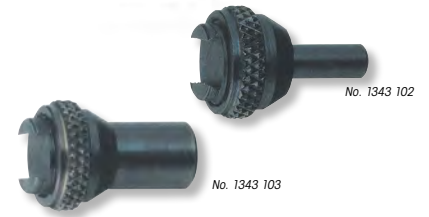

No. 1343 102

No. 1343 103

## Messeinsätze für Fühlhebelmessgeräte

## Measuring inserts for dial test indicators



- ▶ Hartmetall- oder Rubinkugel
- ▶ Anschlussgewinde M 1,6
- ▶ Lieferung einzeln verpackt

- ▶ Tungsten carbide or ruby balls
- ▶ Mounting thread M 1.6
- ▶ Delivered in individual packages

1343 104 – 1343 109 / 1343 113 / 1343 204 :  
Hartmetall

1343 104 – 1343 109 / 1343 113 / 1343 204 :  
Tungsten carbide

1343 110 – 1343 111 :  
Rubin

1343 110 – 1343 111 :  
Ruby

Kugel / Ball Ø mm	l mm	g	Nº	Nº
0,4	12	1	1343 113	-
1	12,3	1	1343 105	-
2	12,8	1	1343 104	1343 110
3	13,3	1	1343 106	-
2	16,6	1	1343 204	-
1	35,2	1	1343 108	-
2	35,7	1	1343 107	1343 111
3	36,2	1	1343 109	-

Messeinsatzschlüssel / Measuring insert spanner

1343 112



## Halter für Fühlhebelmessgeräte

## Dial test indicator holder



- ▶ Normalstahl brüniert
- ▶ Lieferung einzeln verpackt, ohne Messuhr

- ▶ Normal steel burnished
- ▶ Delivered in individual packages, without dial gauge

1343 101 – 1343 201 :  
Messuhraufnahme Ø 4mm und Ø 8mm

1343 101 – 1343 201 :  
Dial mounting hole Ø 4mm and Ø 8mm

1343 301 :  
Schwalbenschwanzklemmung

1343 301 :  
Dovetail clamping

Typ Type	l mm	kg	Nº
Einspannhalter eckig / Clamping holder, angular	6x12x80	0,06	1343 101
Einspannhalter rund / Clamping holder, round	Ø 8x90	0,06	1343 301
Zentrierhalter / Centre holder	-	0,1	1343 201



No. 1343 101

No. 1343 301

No. 1343 201

## Messuhrhalter mit Feineinstellung

## Dial gauge holders with fine adjustment



- ▶ zum Prüfen und Ausrichten von Werkstücken an Bearbeitungsmaschinen
- ▶ Messuhraufnahme Ø 8mm
- ▶ Querarm (A) schwenkbar Ø 12mm
- ▶ Einspannhalter (B) 22x15mm
- ▶ Lieferung einzeln verpackt

- ▶ For checking and aligning workpieces on processing machines
- ▶ Dial mounting hole Ø 8mm
- ▶ Swivel-mounted cross arm (A) Ø 12mm
- ▶ Clamp holder (B) 22 x 15mm
- ▶ Delivered in individual packages

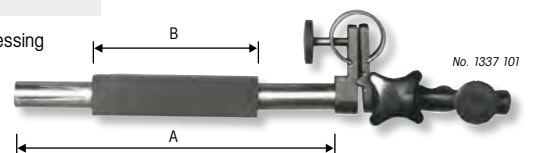

No. 1337 101

A mm	B mm	kg	Nº
185	135	0,3	1337 101

# 5

## Messstative

Measuring stands

## Messuhrständer

Dial gauge stands

## Feinmesstische

Precision measuring tables



**TOP**

Fisso Messstativ BASE-LINE  
Fisso measuring stand BASE-LINE



**5.3**

Fisso Messstativ CLASSIC-LINE  
Fisso measuring stand CLASSIC-LINE



**5.3**

Fisso Messstativ STRATO-LINE  
Fisso measuring stand STRATO-LINE



**5.3**

Messstisch mit Feineinstellung  
Measuring stand with fine adjustment



**5.7**



+49 (0) 60 21 42 999 00

- 1
- 2
- 3
- 4
- 5**
- 6
- 7
- 8
- 9
- 10
- 11
- 12
- 13
- 14
- 15

## ULTRA Keramik-Messtische

Aluminiumoxid ist einer der wichtigsten oxidkeramischen Werkstoffe und wird im Bereich der technischen Keramik in verschiedenen Anwendungsgebieten eingesetzt. Grundlage ist der Rohstoff Bauxit, ein gelbbraunes Sedimentgestein, aus dem Aluminiumoxid durch aufwendige chemische Umwandlungsprozesse gewonnen wird. Die hohe Festigkeit, Härte und Korrosionsbeständigkeit dieses Werkstoffs verleiht den ULTRA Keramik-Messtischen ein Größtmaß an Verschleißfestigkeit und Formstabilität.

### Materialeigenschaften im Vergleich:

Eigenschaften Properties	Keramik Ceramic	Hartgestein Granite	Stahl gehärtet Steel hardened
Längenausdehnungskoeffizient Coefficient of expansion	$7,2 \times 10^{-6} / K$	$5 - 7,5 \times 10^{-6} / K$	$11,5 \times 10^{-6} / K$
Wärmeleitfähigkeit Heat conductivity	niedrig Low	sehr niedrig Very low	hoch High
Härte Hardness	1600 HV 0,5	6 - 7 Mohs-Skala 6 - 7 Mohs' scale	60 HRC $\pm 2$
Verschleißfestigkeit Wear resistance	ausgezeichnet Excellent	sehr gut Very good	sehr gut Very good
Geometrietreue Geometric fidelity	ausgezeichnet Excellent	ausgezeichnet Excellent	sehr gut bei korrekter Behandlung Very good with proper handling
Korrosionsbeständigkeit Corrosion resistance	ausgezeichnet Excellent	ausgezeichnet Excellent	weniger gut Satisfactory
Mechanische Festigkeit Mechanical stability	gut Good	gut Good	sehr gut Very good

## ULTRA ceramic measuring tables

Aluminium oxide is one of the most important oxide ceramic materials and is used in various application areas in the technical ceramic sector. The basis is the raw material bauxite, a yellow-brown sedimentary rock, which is obtained from aluminium oxide through extensive chemical conversion processes. The high stability, hardness and corrosion resistance of this raw material give maximum wear resistance and shape stability to the ULTRA ceramic measuring tables.

### Material properties in comparison:

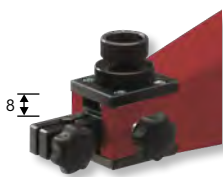

Parallel-Feineinstellung,  
Verstellweg ca. 8mm  
Parallel fine adjustment,  
adjusting range approx. 8mm

Messtische mit Keramikmess-  
fläche siehe Seite 5.8  
Measuring tables with ceramic  
surface see page 5.8



Messtische mit Hartgestein-  
messfläche siehe Seite 5.9  
Measuring tables with granite  
surface see page 5.9



Messtische mit Stahlmess-  
fläche siehe Seite 5.10  
Measuring tables with steel  
surface see page 5.10



### Ebenheit der Messflächen nach DIN 876:

Die Berechnung erfolgt nach den in der Tabelle angegebenen Formeln, die Toleranzen sind gerundet.

Länge $a = \text{mm}$	$\text{Ⓜ} 000$ $(1 + a/1000)\mu$	$\text{Ⓜ} 00$ $(2 + a/500)\mu$	$\text{Ⓜ} 0$ $(4 + a/250)\mu$
100	1,5	2,5	4,5
200	1,5	2,5	5
300	1,5	2,5	5,5
400	1,5	3	6

### Flatness of the measuring surfaces according to DIN 876:

The calculation is done as per the formulas specified in the table, the tolerances are rounded off.

### Kalibrierung:

Für alle Messtische können Werkskalibrierscheine erstellt werden. Bitte beachten Sie hierzu unsere Nettopreisliste für die Erstellung von Prüfberichten.

Weiter Informationen erhalten Sie unter:  
[www.ultra-germany.com](http://www.ultra-germany.com) > Produkte > Service > Prüfmittelüberwachung

### Sondermesstische und Stative:

Wir liefern jede Art von Sondermesstischen und Stativen nach Ihren Zeichnungen – auf Wunsch auch Konzeption und Konstruktion, gegen Berechnung.

Zur Angebotserstellung bitten wir um Ihre Anfragen mit Zeichnungen.

### Calibration:

Works calibration certificates can be issued for all measuring tables. Please check our net price list for the issue of calibration reports.

More information can be had at:  
[www.ultra-germany.com](http://www.ultra-germany.com) > Products > Service > Calibration

### Special measuring tables and stands:

We supply all types of special measuring tables and stands according to your drawings – on request also undertake conception and design at a cost.

For the preparation of a quotation, please send your inquiries with drawings.

## Magnet-Messtativ mit mechanischer Zentralklemmung BASE-LINE

## Magnetic measuring stand with mechanical centre lock BASE-LINE



No. 1400 301



- ▶ Querarm beliebig verstellbar, mit Feineinstellung
- ▶ Gestänge verchromt
- ▶ Magnetteuß mit prismatischer Sohle
- ▶ Magnet ein- ausschaltbar
- ▶ Messuhraufnahme Ø 8mm
- ▶ Lieferung einzeln verpackt, ohne Messuhr

- ▶ Freely adjustable arm with fine adjustment
- ▶ Chrome-plated linkage
- ▶ Magnetic V base
- ▶ Switchable magnet
- ▶ Dial mounting hole Ø 8mm
- ▶ Delivered in individual packages, without dial gauge

h mm	Ø mm	Kp	Fuß / Base mm	kg	Nº
277	10 / 8	30	34x30x35	0,5	1400 301
367	12 / 10	75	60x50x55	1,66	1400 302
453	14 / 12	75	60x50x55	1,85	1400 303

## Magnet-Messtativ mit mechanischer Zentralklemmung CLASSIC-LINE

## Magnetic measuring stand with mechanical centre lock CLASSIC-LINE

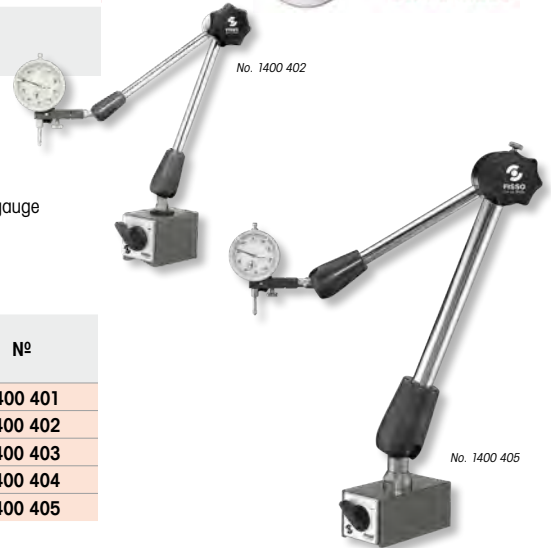

No. 1400 402

No. 1400 405



- ▶ Querarm beliebig verstellbar, mit Feineinstellung
- ▶ Gestänge verchromt
- ▶ Magnetteuß mit prismatischer Sohle
- ▶ Magnet ein- ausschaltbar
- ▶ Messuhraufnahme Ø 8mm
- ▶ Lieferung einzeln verpackt, ohne Messuhr

- ▶ Freely adjustable arm with fine adjustment
- ▶ Chrome-plated linkage
- ▶ Magnetic V base
- ▶ Switchable magnet
- ▶ Dial mounting hole Ø 8mm
- ▶ Delivered in individual packages, without dial gauge

Aktionsradius Operation range mm	Kp	Fuß / Base mm	Gewinde / Thread	kg	Nº
200	80	60x50x55	M8	1,54	1400 401
280	80	60x50x55	M8	1,95	1400 402
400	100	75x50x55	M8	2,2	1400 403
450	100	75x50x55	M8	2,9	1400 404
630	150	120x60x55	M10x1,25	6,0	1400 405

## Magnet-Messtativ mit mechanischer Zentralklemmung STRATO-LINE

## Magnetic measuring stand with mechanical centre lock STRATO-LINE

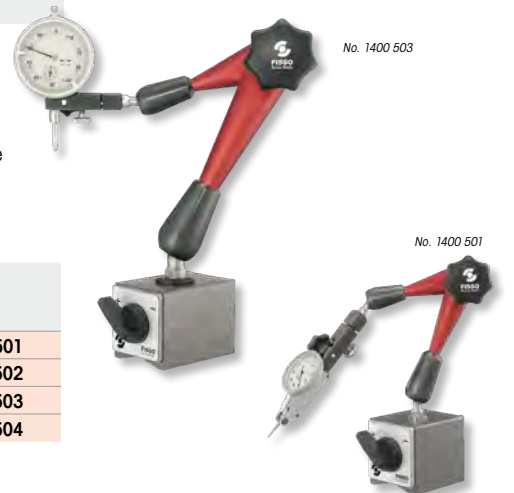

No. 1400 503

No. 1400 501



- ▶ Querarm beliebig verstellbar, mit Feineinstellung
- ▶ Gestänge aus Aluminium
- ▶ Magnetteuß mit prismatischer Sohle
- ▶ Magnet ein- ausschaltbar
- ▶ Messuhraufnahme Ø 8mm
- ▶ Lieferung einzeln verpackt, ohne Messuhr

- ▶ Freely adjustable arm with fine adjustment
- ▶ Aluminium linkage
- ▶ Magnetic V base
- ▶ Switchable magnet
- ▶ Dial mounting hole Ø 8mm
- ▶ Delivered in individual packages, without dial gauge

Aktionsradius Operation range mm	Kp	Fuß / Base mm	Gewinde / Thread	kg	Nº
130	30	34x30x35	M6	0,45	1400 501
200	80	60x50x55	M8	1,45	1400 502
280	80	60x50x55	M8	1,85	1400 503
280	100	75x50x55	M8	2,2	1400 504

## Magnet-Messstativ mit mechanischer Zentralklemmung

## Magnetic measuring stand with mechanical centre lock



- ▶ Querarm beliebig verstellbar, mit Feineinstellung
- ▶ Messuhraufnahme Ø 8mm
- ▶ Lieferung in Holzetui, ohne Messuhr

- ▶ Freely adjustable arm with fine adjustment
- ▶ Dial mounting hole Ø 8mm
- ▶ Delivered in wooden box, without dial gauge

**1403 1.. / 1404 102 :**

Messstativ ohne Holzetui

**1403 1.. / 1404 102 :**

Measuring stands without wooden box

**1403 1..h / 1404 102h :**

Messstativ mit Holzetui

**1403 1..h / 1404 102h :**

Measuring stands with wooden box



No. 1403 102

No. 1404 102

No. 1403 101h

Aktionsradius / Operating range mm	↑ Kp	Fuß / Base mm	↑ kg	Nº	Nº
Magnetfuß ein- ausschaltbar, mit prismatischer Sohle / Switchable magnetic V base					
240	60	60x50x55	1,7	1403 101	1403 101h
360	60	70x46x65	2,8	1403 102	1403 102h
Vakuum Haftfuß ein- ausschaltbar / Switchable vacuum base					
360	25	Ø 90	2,0	1404 102	1404 102h

## Magnet-Messstativ System Bosch mit Kreuzklemmung

## Magnetic measuring stand systems, Bosch with swivel clamp



- ▶ Querarm beliebig verstellbar, mit Feineinstellung
- ▶ Gestänge hartverchromt
- ▶ Magnetfuß mit prismatischer Sohle
- ▶ Magnet ein- ausschaltbar
- ▶ Messuhraufnahme Ø 8mm
- ▶ Lieferung einzeln verpackt

- ▶ Freely adjustable arm with fine adjustment
- ▶ Hard chrome-plated linkage
- ▶ Magnetic V base
- ▶ Switchable magnet
- ▶ Dial mounting hole Ø 8mm
- ▶ Delivered in individual packages

**1400 201 / 1400 202 :**

Messstativ ohne Holzetui

**1400 201 / 1400 202 :**

Measuring stands without wooden box

**1400 201h / 1400 202h :**

Messstativ mit Holzetui

**1400 201h / 1400 202h :**

Measuring stands with wooden box

⊥ mm	⊘ mm	≡ mm	↑ Kp	Fuß / Base mm	↑ kg	Nº	Nº
280	16/16	230	60	70x46x65	3,2	1400 201	1400 201h
500	20/16	420	80	78x60x80	5,7	1400 202	1400 202h



No. 1400 201



No. 1400 201h

## Magnet-Messstativ Stahlgliederarm, flexibel

## Magnetic measuring stand with flexible steel arm



- ▶ Magnetfuß mit prismatischer Sohle
- ▶ Magnet ein- ausschaltbar
- ▶ Messuhraufnahme Ø 8mm
- ▶ Lieferung einzeln verpackt, ohne Messuhr

- ▶ Magnetic V base
- ▶ Switchable magnet
- ▶ Dial mounting hole Ø 8mm
- ▶ Delivered in individual packages, without dial gauge

⊥ mm	⊘ mm	≡ mm	↑ Kp	Fuß / Base mm	↑ kg	Nº
350	16	200	60	70x46x65	1,8	1401 101



No. 1401 101



## Feineinstellung für Messstative Fine adjustment for measuring stands



- ▶ Messuhraufnahme Ø 8mm
- ▶ Lieferung einzeln verpackt

- ▶ Dial mounting hole Ø 8mm
- ▶ Delivered in individual packages

Gewinde Thread	⊞ kg	Nº
M6	0,2	1409 901
M8	0,2	1409 902



No. 1409 901

## Standfüße für Messstative Base for measuring stands



- ▶ Lieferung einzeln verpackt

- ▶ Delivered in individual packages

- 1 = Magnetfuß mit prismatischer Sohle schaltbar
- 2 = Magnetfuß mit prismatischer Sohle schaltbar, System Bosch
- 3 = Magnetfuß, permanent
- 4 = Vakuumhauffuß, schaltbar

- 1 = Switchable magnetic base with V groove
- 2 = Switchable magnetic base with V groove, Bosch system
- 3 = Permanent magnetic base
- 4 = Switchable vacuum base

Typ Type	L mm	⊞ Kp	Gewinde Thread	⊞ kg	Nº
1	60x50x55	60	M8	1,2	1409 202
1	60x50x55	60	M10	1,2	1409 203
1	123x50x55	120	M8	2,3	1409 205
2	70x46x65	60	M8	1,3	1409 301
2	78x60x80	80	M10	2,3	1409 302
3	Ø 35x30	25	M6	0,2	1409 401
3	Ø 40x30	40	M8	0,5	1409 402
4	Ø 100x20	40	M10	0,4	1409 501



No. 1409 202



No. 1409 301



No. 1409 205



No. 1409 302



No. 1409 501



No. 1409 401

## Magnet-Halter Magnetic holder



- ▶ kräftiger Dauermagnet
- ▶ Messuhraufnahme Ø 8mm
- ▶ Lieferung einzeln verpackt, ohne Messuhr

- ▶ Sturdy permanent magnet
- ▶ Dial mounting hole Ø 8mm
- ▶ Delivered in individual packages, without dial gauge

**1336 101 :**  
Halter starr

**1336 101 :**  
Holder rigid

**1336 102 / 103 :**  
Halter mit schwenkbarem Querarm

**1336 102 / 103 :**  
Holder with movable arm

⊞ mm	≡ mm	⊞ Kp	Fuß / Base mm	⊞ kg	Nº
60	-	13	Ø 46 (flach / flat)	0,2	1336 101
46	35	18	73x38x11 (flach / flat)	0,3	1336 102
59	35	18	73x37x26 (Prisma / V base)	0,4	1336 103



No. 1336 101



No. 1336 102



No. 1336 103

## Magnet-Messtativ STANDARD mit Kreuzklemmung

## Magnetic measuring stands, STANDARD with swivel clamp



- ▶ Querarm beliebig verstellbar, mit Feineinstellung
- ▶ Gestänge hartverchromt
- ▶ Magnettoß mit prismatischer Sohle
- ▶ Magnet ein- ausschaltbar
- ▶ Messuhraufnahme Ø 8mm
- ▶ Lieferung einzeln verpackt

- ▶ Freely adjustable arm with fine adjustment
- ▶ Hard chrome-plated linkage
- ▶ Magnetic V base
- ▶ Switchable magnet
- ▶ Dial mounting hole Ø 8mm
- ▶ Delivered in individual packages

**I** Holzetui auf Anfrage.

**I** Wooden box on request.

ℓ mm	Ø mm	ℓ mm	↑ Kp	Fuß / Base mm	⚖ kg	Nº
240	12/10	150	60	60x50x55	1,9	5044 101
280	16/16	180	60	60x50x55	2,4	5044 102



No. 5044 101

## Magnet-Messtativ STANDARD mit mechanischer Zentralklemmung

## Magnetic measuring stand, STANDARD with mechanical centre lock



- ▶ Querarm beliebig verstellbar, mit Feineinstellung
- ▶ Magnettoß mit prismatischer Sohle
- ▶ Magnet ein- ausschaltbar
- ▶ Messuhraufnahme Ø 8mm
- ▶ Lieferung einzeln verpackt

- ▶ Freely adjustable arm with fine adjustment
- ▶ Magnetic V base
- ▶ Switchable magnet
- ▶ Dial mounting hole Ø 8mm
- ▶ Delivered in individual packages

Aktionsradius / Operating range mm	↑ Kp	Fuß / Base mm	⚖ kg	Nº
150	20	40x30x35	0,4	5044 201
300	60	60x50x55	1,7	5044 202



No. 5044 201

No. 5044 202

## Magnet-Messtativ

## Magnetic measuring stands



- ▶ Querarm beliebig verstellbar, mit Feineinstellung
- ▶ Gestänge mit Kreuzklemmung
- ▶ Magnettoß rund – permanent
- ▶ Messuhraufnahme Ø 8mm
- ▶ Lieferung einzeln verpackt, ohne Messuhr

- ▶ Freely adjustable arm with fine adjustment
- ▶ Linkage with swivel clamp
- ▶ Round magnetic base – permanent
- ▶ Dial mounting hole Ø 8mm
- ▶ Delivered in individual packages, without dial gauge

ℓ mm	Ø mm	ℓ mm	↑ Kp	Fuß / Base mm	⚖ kg	Nº
190	10	130	40	Ø 40	0,6	1407 101



No. 1407 101

## Universal-Messtativ

## Measuring stand, universal



- ▶ Querarm beliebig verstellbar, mit Feineinstellung
- ▶ Gestänge mit Kreuzklemmung, hartverchromt
- ▶ Standfuß aus Spezialguss
- ▶ Messuhraufnahme Ø 8mm
- ▶ Lieferung einzeln verpackt, ohne Messuhr

- ▶ Freely adjustable arm with fine adjustment
- ▶ Hard chrome-plated linkage with swivel clamp
- ▶ Special cast iron base
- ▶ Dial mounting hole Ø 8mm
- ▶ Delivered in individual packages, without dial gauge

**1410 102 :**  
Fuß mit H-Profil

**1410 102 :**  
Base with H-profile

**1411 102 :**  
Fuß mit Prisma

**1411 102 :**  
Base with V groove

ℓ mm	Ø mm	ℓ mm	Fuß / Base mm	⚖ kg	Nº	Nº
300	16	180	250x60	3,8	1410 102	1411 102



No. 1411 102

**Messuhrständer**

**Dial gauge stands**



- ▶ Querarm beliebig verstellbar, mit Feineinstellung
- ▶ Gestänge mit Kreuzklemmung, hartverchromt
- ▶ Standfuß aus Spezialstahl, mit Messfläche
- ▶ Messuhraufnahme Ø 8mm
- ▶ Lieferung einzeln verpackt

- ▶ Freely adjustable arm with fine adjustment
- ▶ Hard chrome-plated linkage with swivel clamp
- ▶ Special steel base, with measuring surface
- ▶ Dial mounting hole Ø 8mm
- ▶ Delivered in individual packages

h mm	Ø mm	l mm	Fuß / Base Ø mm	kg	Nº
500	25	200	200x80	5,0	1413 101
750	25	200	200x80	6,0	1413 102
1000	25	400	250x100	11,0	1413 103



No. 1413 101

**Messuhrständer**

**Schwere Ausführung**

**Dial gauge stands  
heavy duty**



- ▶ Querarm verschiebbar, mit Feineinstellung
- ▶ mit schwerer Stahlbasis gehärtet, mit Staubnuten
- ▶ frei verschiebbar, ohne T-Nutführung
- ▶ Messuhraufnahme Ø 8mm
- ▶ Höhenverstellung durch Steilgewinde mit Stellring
- ▶ Lieferung einzeln verpackt

- ▶ Adjustable arm with fine adjustment
- ▶ With heavy hardened steel base, with dust grooves
- ▶ Free moveable, without T-Slots
- ▶ Dial mounting hole Ø 8mm
- ▶ Height adjustment by helical thread with adjusting ring
- ▶ Delivered in individual packages

! Größere Messhöhen sowie Sonderstative auf Anfrage.

! Larger measuring heights and special stands on request.

h mm	l mm	Ø mm	kg	Nº
500	300	35	12,0	1549 501



No. 1549 501

**Messstativ mit Feineinstellung**

**Measuring stand with fine adjustment**



- ▶ schwere Ausführung für Messvorrichtungen
- ▶ Querarm beliebig verstellbar, mit Feineinstellung
- ▶ Feinverstellung über Einstellschraube am Querarm
- ▶ Gestänge mit Außengewinde M12
- ▶ Gestänge hartverchromt
- ▶ Messuhraufnahme Ø 8mm
- ▶ Lieferung einzeln verpackt, ohne Messuhr

- ▶ Heavy version for measuring devices
- ▶ Freely adjustable arm with fine adjustment
- ▶ Fine adjustment through adjusting screw on the arm
- ▶ Stand with Outer-Thread M12
- ▶ Hard chrome-plated linkage
- ▶ Dial mounting hole Ø 8mm
- ▶ Delivered in individual packages without dial gauge

! Größere Messhöhen sowie Sonderstative auf Anfrage.

! Larger measuring heights and special stands on request.

h mm	Ø mm	l mm	kg	Nº
360	35	200	10,0	1430 301

Einstellschraube für Feineinstellung  
Fine adjustment through screw



No. 1430 301

**Sondermesstische und Stative**

**Special measuring tables and stands**



Wir liefern jede Art von Sondermesstischen und Stativen nach Ihren Zeichnungen – auf Wunsch auch Konzeption und Konstruktion, gegen Berechnung.

We supply all types of special measuring tables and stands according to your drawings – on request also undertake conception and design at a cost.



## Feinmesstische mit Keramik-Messfläche

## Precision measuring tables with ceramic surface



Klemmhebel  
Clamping lever

- ▶ DIN 876/000
- ▶ Messfläche extrem hart und korrosionsbeständig absolut verschleißfest
- ▶ Standfuß aus Spezialguss
- ▶ Messuhraufnahme Ø 8mm
- ▶ Lieferung einzeln verpackt

- ▶ DIN 876/000
- ▶ Extremely hard, anti-corrosive and absolutely wear-resistant measuring surface
- ▶ Special cast iron base
- ▶ Dial mounting hole Ø 8mm
- ▶ Delivered in individual packages

**1418 103k :**  
Messfläche rund ohne Staubnuten

**1418 103k :**  
Measuring surface round without dust grooves

**1420 101k / 1422 101k :**  
Messfläche mit Staubnuten

**1420 101k / 1422 101k :**  
Measuring surface with dust grooves

■ mm	┌ mm	∅ mm	└ mm	⚖ kg	№
Querarm verschiebbar / Adjustable arm					
70x60	100	22	75	3,5	1420 101k
Querarm starr / Rigid arm					
∅ 50	100	22	50	2,0	1418 103k
70x60	100	22	50	3,5	1422 101k



## Feinmesstische mit Keramik-Messfläche

## Precision measuring tables with ceramic surface



Klemmhebel  
Clamping lever

- ▶ DIN 876/000
- ▶ Messfläche mit Staubnuten, extrem hart und korrosionsbeständig absolut verschleißfest
- ▶ Standfuß aus Spezialguss
- ▶ Messuhraufnahme Ø 8mm
- ▶ Höhenverstellung durch Steilgewinde mit Stelling
- ▶ Lieferung einzeln verpackt

- ▶ DIN 876/000
- ▶ Extremely hard, anti-corrosive and absolutely wear-resistant measuring surface with dust grooves
- ▶ Special cast iron base
- ▶ Dial mounting hole Ø 8mm
- ▶ Height adjustment by helical thread with adjusting ring
- ▶ Delivered in individual packages

! Größere Messhöhen sowie Sonderstativ auf Anfrage.

! Larger measuring heights and special stands on request.

■ mm	┌ mm	∅ mm	└ mm	⚖ kg	№
Querarm verschiebbar / Adjustable arm					
180x105	200	35	180	14,0	1420 102k
180x215	200	35	180	21,0	1420 103k
Querarm starr / Rigid arm					
180x105	200	35	120	14,0	1422 102k
180x215	200	35	120	21,0	1422 103k
Querarm starr mit Feineinstellung / Rigid arm with fine adjustment					
180x105	200	35	130	14,0	1426 101k
180x215	200	35	130	21,0	1426 102k



Parallel-Feineinstellung,  
Verstellweg ca. 8mm  
Parallel fine adjustment,  
adjusting range approx. 8mm

Feineinstellung  
Fine adjustment

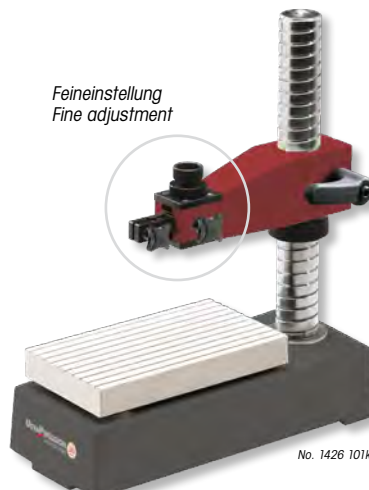

**Feinmesstische  
mit Hartgestein-Messfläche**

**Precision measuring tables  
with granite surface**



- ▶ DIN 876/00
- ▶ Messfläche und Standfuß aus Hartgestein
- ▶ Messuhraufnahme Ø 8mm
- ▶ Lieferung einzeln verpackt

- ▶ DIN 876/00
- ▶ Granite measuring surface and base
- ▶ Dial mounting hole Ø 8mm
- ▶ Delivered in individual packages

A mm	L1 mm	L2 mm	⏊ mm	∅ mm	≡ mm	⚖ kg	Nº
Kreuzklemmung und Feineinstellung / Swivel clamp and fine adjustment							
100	170	130	180	16	150	2,7	1412 101
Querarm verschiebbar / Adjustable arm							
100	170	130	150	22	75	2,6	1419 101
Querarm starr / Rigid arm							
100	170	130	150	22	50	2,5	1421 101

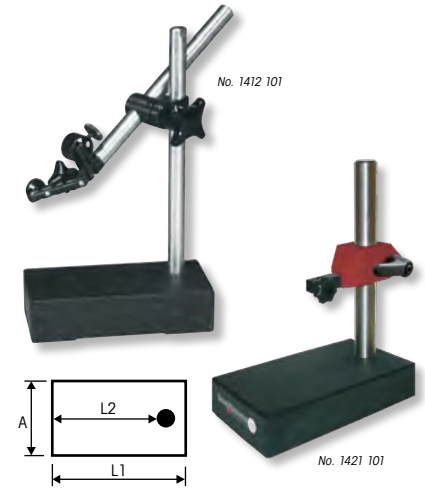

**Feinmesstische  
mit Hartgestein-Messfläche**

**Precision measuring tables  
with granite surface**



- ▶ DIN 876/00
- ▶ Messfläche und Standfuß aus Hartgestein
- ▶ Messuhraufnahme Ø 8mm
- ▶ Höhenverstellung durch Steilgewinde mit Stelling
- ▶ Lieferung einzeln verpackt

- ▶ DIN 876/00
- ▶ Granite measuring surface and base
- ▶ Dial mounting hole Ø 8mm
- ▶ Height adjustment by helical thread with adjusting ring
- ▶ Delivered in individual packages

! Andere Größen sowie Sonderstativ auf Anfrage.

! Other sizes and special stands on request.

A mm	L1 mm	L2 mm	⏊ mm	∅ mm	≡ mm	⚖ kg	Nº
Querarm verschiebbar / Adjustable arm							
150	250	200	200	35	180	10,0	1419 102
200	300	230	200	35	180	14,0	1419 103
250	420	350	400	35	250	28,0	1419 104
300	470	400	400	35	300	46,0	1419 105
Querarm starr / Rigid arm							
150	250	200	200	35	120	10,0	1421 102
200	300	230	200	35	120	14,0	1421 103
Querarm starr mit Feineinstellung / Rigid arm with fine adjustment							
150	250	200	200	35	130	10,0	1423 101
200	300	230	200	35	130	14,0	1423 102



Parallel-Feineinstellung,  
Verstellweg ca. 8mm  
Parallel fine adjustment,  
adjusting range approx. 8mm

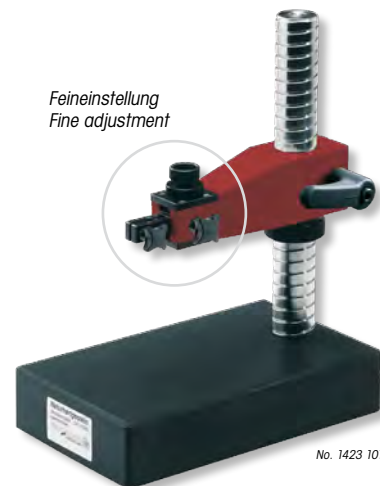

Feineinstellung  
Fine adjustment



No. 1421 102

## Feinmesstische mit Stahl-Messfläche

## Precision measuring tables with steel measuring surface



Klemmhebel  
Clamping lever

- ▶ DIN 876/0
- ▶ Messfläche gehärtet
- ▶ Standfuß aus Spezialguss
- ▶ Messuhrenaufnahme Ø 8mm
- ▶ Lieferung einzeln verpackt, ohne Messuhr

- ▶ DIN 876/0
- ▶ Hardened measuring surface
- ▶ Special cast iron base
- ▶ Dial mounting hole Ø 8mm
- ▶ Delivered in individual packages, without dial gauge

■ mm	┌ mm	⊘ mm	└ mm	⚖ kg	Nº
Ø 20	25	-	40	1,2	1418 101
Querarm verschiebbar / Adjustable arm					
70x60	100	22	75	3,5	1420 101
Querarm starr / Rigid arm					
Ø 50	100	22	50	2,0	1418 103
70x60	100	22	50	3,5	1422 101



## Feinmesstische mit Stahl-Messfläche

## Precision measuring tables with steel measuring surface



Klemmhebel  
Clamping lever

- ▶ DIN 876/0
- ▶ Messfläche gehärtet mit Staubnuten
- ▶ Standfuß aus Spezialguss
- ▶ Messuhrenaufnahme Ø 8mm
- ▶ Höhenverstellung durch Steilgewinde mit Stellingring
- ▶ Lieferung einzeln verpackt

- ▶ DIN 876/0
- ▶ Hardened measuring surface with dust grooves
- ▶ Special cast iron base
- ▶ Dial mounting hole Ø 8mm
- ▶ Height adjustment by helical thread with adjusting ring
- ▶ Delivered in individual packages

■ mm	┌ mm	⊘ mm	└ mm	⚖ kg	Nº
Querarm verschiebbar / Adjustable arm					
180x105	200	35	180	14,0	1420 102
180x215	200	35	180	21,0	1420 103
350x250	400	50	250	40,0	1420 104
400x300	400	50	300	60,0	1420 105
Querarm starr / Rigid arm					
180x105	200	35	120	14,0	1422 102
180x215	200	35	120	15,0	1422 103
Querarm starr mit Feineinstellung / Rigid arm with fine adjustment					
180x105	200	35	130	14,0	1426 101
180x215	200	35	130	21,0	1426 102



Parallel-Feineinstellung,  
Verstellweg ca. 8mm  
Parallel fine adjustment,  
adjusting range approx. 8mm

Feineinstellung  
Fine adjustment

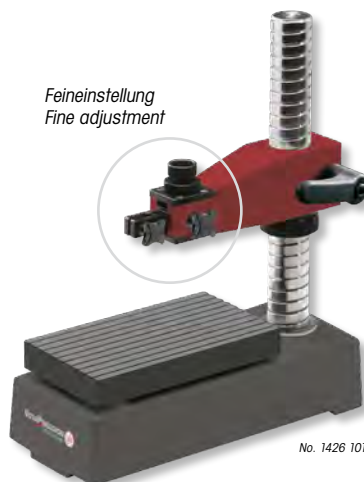

# 6

## Schnelltaster

Dial caliper gauges

## Dickenmessgeräte

Thickness gauges

## Tiefenmessgeräte

Dial depth gauges

## Innenfeinmessgeräte

Precision bore gauges

## Vergleichsmessgeräte

Comparative meas. instruments

## Zentriergeräte

Centring devices



★ **NEW**

**Nutsymmetriemessgerät**  
Digital calipers for slot center distance measuring



6.8

**Digital-Innenfeinmessdorne MICROGAUGE**  
Digital precision bore gauges MICROGAUGE



6.14

**Universalvergleichsmessgerät QUICK CHECK**  
Universal comparative measuring bench QUICK CHECK



6.24

**Vergleichsmessgeräte CARBON**  
Comparative measuring instrument CARBON



6.38

## Digital-Schnellfaster für Innenmessung

## Digital dial caliper gauges for internal measurement

**Kroepelin**  
Längenmesstechnik



IP67

- ▶ Werksnorm
- ▶ Schutzart IP 67
- ▶ großes LCD-Display
- ▶ digitale Skala (Segmentanzeige)
- ▶ 1 fester, 1 beweglicher Tastarm
- ▶ Messkontakte Hartmetall-Kugel (Nr. 1350 301 Schneide)
- ▶ Lieferung inkl. Werkskalibrierschein in Kartonbox

### Funktionen:

- ▶ Ein/Aus
- ▶ mm/inch Umschaltung
- ▶ 0-Punkt an jeder Position
- ▶ ABS / Relativ Modus
- ▶ Skalenteilungswert umschaltbar 0,1 / 0,01mm
- ▶ Toleranzampel LED rot/grün
- ▶ Datenausgang

- ▶ Works standard
- ▶ Protection class IP 67
- ▶ Large LCD display
- ▶ Digital scale (segment display)
- ▶ 1 fixed and 1 movable arm
- ▶ Tungsten carbide contact balls (No. 1350 101 shape)
- ▶ Delivered incl. works calibration certificate in cardboard box

### Functions:

- ▶ On/Off
- ▶ mm/inch commutation
- ▶ Zero setting at any position
- ▶ ABS / Relative mode
- ▶ Reversible scale interval 0.1 / 0.01mm
- ▶ Tolerance signal lights LED red/green
- ▶ Data output



No. 1350 303



No. 1350 213

**I** Andere Messbereiche, Tasterformen und Holzetuis auf Anfrage.

**I** Other measuring ranges, other probes and wooden boxes on request.

**I** Kabellose Funk-Datenübertragung auf Anfrage.

**I** Wireless radio transmission on request.

mm	$\Delta$ mm	mm	N	Taster probe $\varnothing$ mm	L mm	A mm	B mm	$\bar{m}$ kg	Nº	Datenkabel Data cable
2,5 – 12,5	0,005	0,015	0,8 – 1,2	R 0,1	35	0,7	0,4	0,35	1350 301	13506-*
5 – 15	0,005	0,015	0,8 – 1,2	0,6	35	2,3	0,8	0,35	1350 302	
10 – 30	0,01	0,03	1,1 – 1,6	1	85	5,2	1,2	0,35	1350 303	
20 – 40	0,01	0,03	1,1 – 1,6	1	85	7	1,2	0,35	1350 304	
30 – 50	0,01	0,03	1,1 – 1,6	1	85	7	1,2	0,35	1350 305	
40 – 60	0,01	0,03	1,1 – 1,6	1	85	8,3	1,2	0,35	1350 306	
50 – 70	0,01	0,03	1,1 – 1,6	1	85	8,3	1,2	0,35	1350 307	
60 – 80	0,01	0,03	1,1 – 1,6	1	85	8,3	1,2	0,35	1350 308	
70 – 90	0,01	0,03	1,1 – 1,6	1	85	8,3	1,2	0,35	1350 309	
80 – 100	0,01	0,03	1,1 – 1,6	1	85	8,3	1,2	0,35	1350 310	
Ausführung mit langen Tastarmen / Model with long arms										
13 – 43	0,02	0,04	1,2 – 1,7	1,3	127	5,7	1,6	0,36	1350 115	13506-*
30 – 60	0,02	0,04	1,2 – 1,7	1,5	132	6,2	1,8	0,37	1350 116	
50 – 80	0,02	0,04	1,2 – 1,7	2	132	8,3	2,4	0,37	1350 117	
70 – 100	0,02	0,04	1,2 – 1,7	2	132	8,3	2,4	0,38	1350 118	
90 – 120	0,02	0,04	1,2 – 1,7	2	132	8,3	2,4	0,38	1350 119	
15 – 65	0,02	0,06	1,0 – 1,8	1,5	188	5,5	1,9	0,42	1350 212	
40 – 90	0,02	0,06	1,0 – 1,8	2,0	192	8,3	2,4	0,42	1350 213	

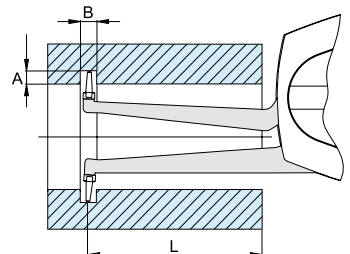
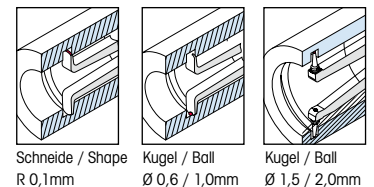

### \* Bestellhinweis für Datenkabel:

Für Datenkabel bitte die gewünschte Ausführung (USB oder Digimatic) angeben.  
Beispiel: Nr. 13506- mit USB = Nr. 13506-USB  
Beispiel: Nr. 13506- mit Digimatic = Nr. 13506-DIGI

### \* Order advice for datacable:

For data cable please mention the required version (USB or Digimatic).  
Example: No. 13506- with USB = No. 13506-USB  
Example: No. 13506- with Digimatic = No. 13506-DIGI



**Digital Schnelltaster  
für Dreipunkt-Innenmessung**

**Digital dial caliper gauges  
for 3-Point internal measurement**

**Kroepelin**  
Längenmesstechnik



- ▶ Werksnorm
- ▶ Schutzart IP 67
- ▶ großes LCD-Display
- ▶ digital Skala (Segmentanzeige)
- ▶ 1 fester, 1 beweglicher Tastarm
- ▶ Messkontakte Hartmetall-Kugel
- ▶ Lieferung inkl. Werkskalibrierschein in Kartonbox

**Funktionen:**

- ▶ Ein/Aus
- ▶ mm/inch Umschaltung
- ▶ 0-Punkt an jeder Position
- ▶ ABS / Relativ Modus
- ▶ Skalenteilungswert umschaltbar 0,1 / 0,01mm
- ▶ Toleranzampel LED rot / grün
- ▶ Datenausgang

**Vorteil 3-Punkt Antastung:**

- ▶ bessere Zentrierung
- ▶ schnelle Messwertfindung
- ▶ sichere Messung
- ▶ genaue Messergebnisse
- ▶ hohe Wiederholungsgenauigkeit
- ▶ einfache Handhabung

- ▶ Works standard
- ▶ Protection class IP 67
- ▶ Large LCD display
- ▶ Digital scale (segment display)
- ▶ 1 fixed and 1 moveable arm
- ▶ Tungsten carbide contact balls
- ▶ Delivered incl. works calibration certificate in cardboard box

**Functions:**

- ▶ On/Off
- ▶ mm/inch commutation
- ▶ Zero setting at any position
- ▶ ABS / Relative mode
- ▶ Reversible scale interval 0.1 / 0.01mm
- ▶ Tolerance signal lights LED red / green
- ▶ Data output

**Advantage of 3-point contact:**

- ▶ Better centering
- ▶ Quick determination of the measured value
- ▶ Reliable measuring
- ▶ Accurate measuring results
- ▶ High precision of repeatability
- ▶ Easy handling



No. 1350 701



No. 1350 704



No. 1350 703

! Kabellose Funk-Datenübertragung auf Anfrage.

! Wireless radio transmission on request.

Spannweite mm	Skalenteilung mm	Skalenteilung mm	Skalenteilung N	Taster probe Ø mm	L mm	A mm	B mm	Gewicht kg	Tasterform Probe contacts	Nr.	Datenkabel Data cable
7 - 14	0,002	0,01	1,0 - 1,4	0,6	34	2,2	0,8	0,23	1	1350 701	13506-*
10 - 20	0,005	0,02	1,1 - 1,6	1	75	3,5	1,6	0,25	2	1350 702	
15 - 30	0,005	0,02	1,1 - 1,6	1	77	5,0	1,5	0,28	2	1350 703	
25 - 45	0,005	0,02	1,1 - 1,6	1	84	7,0	1,6	0,26	3	1350 704	
40 - 60	0,005	0,02	1,1 - 1,6	1	84	8,0	1,6	0,27	3	1350 705	
55 - 75	0,005	0,02	1,1 - 1,6	1	84	8,0	1,6	0,27	3	1350 706	
70 - 90	0,005	0,02	1,1 - 1,6	1	84	8,5	1,6	0,28	3	1350 707	
85 - 105	0,005	0,02	1,1 - 1,6	1	84	9,0	1,6	0,29	3	1350 708	

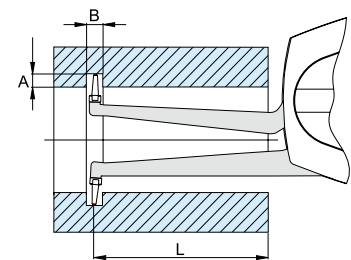

**\* Bestellhinweis für Datenkabel:**

Für Datenkabel bitte die gewünschte Ausführung (USB oder Digimatic) angeben.  
Beispiel: Nr. 13506- mit USB = Nr. 13506-USB  
Beispiel: Nr. 13506- mit Digimatic = Nr. 13506-DIGI

**\* Order advice for datacable:**

For data cable please mention the required version (USB or Digimatic).  
Example: No. 13506- with USB = No. 13506-USB  
Example: No. 13506- with Digimatic = No. 13506-DIGI



Tasterform / probe contacts 1  
Kugel / Ball Ø 0,6mm



Tasterform / probe contacts 2  
Kugel / Ball Ø 1,0mm



Tasterform / probe contacts 3  
Kugel / Ball Ø 1,0mm

**Schnellfaster  
für Innenmessung**

**Dial caliper gauges  
for internal measurement**

**Kroepelin**  
Längenmesstechnik



IP65

- ▶ Werksnorm
- ▶ Schutzart IP 65
- ▶ Toleranzmarken einstellbar
- ▶ 1 fester, 1 beweglicher Tastarm
- ▶ Messkontakte Hartmetall-Kugel (Nr. 1354 100 Schneide)
- ▶ Lieferung inkl. Werkskalibrierschein in Kartonbox

- ▶ Works standard
- ▶ Protection class IP 65
- ▶ Adjustable tolerance marks
- ▶ 1 fixed and 1 movable arm
- ▶ Tungsten carbide contact balls (No. 1354 100 shape)
- ▶ Delivered incl. works calibration certificate in cardboard box



No. 1352 101



No. 1352 206

! Andere Messbereiche, Tasterformen und Holzetuis auf Anfrage.

! Other measuring ranges, other probes and wooden boxes on request.

mm	<math>\leq</math> mm	mm	N	Taster probe $\varnothing$ mm	L mm	A mm	B mm	kg	Nº
2,5 - 12,5	0,005	0,015	0,8 - 1,2	R 0,1	35	0,7	0,4	0,14	1354 100
5 - 15	0,005	0,015	0,8 - 1,2	0,6	35	2,3	0,8	0,14	1354 101
10 - 30	0,01	0,03	1,1 - 1,6	1	85	5,2	1,2	0,24	1352 101
20 - 40	0,01	0,03	1,1 - 1,6	1	85	7	1,2	0,26	1352 102
30 - 50	0,01	0,03	1,1 - 1,6	1	85	7	1,2	0,26	1352 103
40 - 60	0,01	0,03	1,1 - 1,6	1	85	8,3	1,2	0,3	1352 104
50 - 70	0,01	0,03	1,1 - 1,6	1	85	8,3	1,2	0,3	1352 105
60 - 80	0,01	0,03	1,1 - 1,6	1	85	8,3	1,2	0,31	1352 106
70 - 90	0,01	0,03	1,1 - 1,6	1	85	8,3	1,2	0,31	1352 107
80 - 100	0,01	0,03	1,1 - 1,6	1	85	8,3	1,2	0,31	1352 108

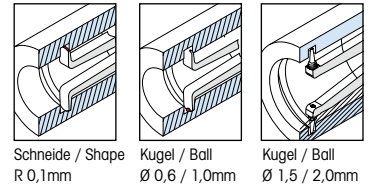

Schneide / Shape R 0,1mm      Kugel / Ball Ø 0,6 / 1,0mm      Kugel / Ball Ø 1,5 / 2,0mm

Ausführung mit auswechselbaren Tastern (Vergleichsmessgeräte)  
Model with interchangeable probes (comparison measurement)

50 - 100	0,01	0,03	1,1 - 1,6	1	85	8,3	1,2	0,35	1354 125
90 - 140	0,01	0,03	1,1 - 1,6	1	85	8,3	1,2	0,35	1354 126
130 - 180	0,01	0,03	1,1 - 1,6	1	85	8,3	1,2	0,35	1354 127

Ausführung mit langen Tastarmen  
Model with long arms

15 - 65	0,05	0,05	0,9 - 1,9	1,5	188	5,5	1,9	0,36	1352 206
40 - 90	0,05	0,05	0,9 - 1,9	2	192	8,3	2,4	0,37	1352 308
70 - 120	0,05	0,05	0,9 - 1,9	2	192	8,3	2,4	0,37	1352 309

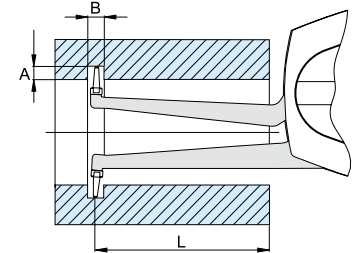

**Digital-Schnellfaster für Außenmessung**

**Digital dial caliper gauges for external measurement**

**Kroepelin**  
 Längenmesstechnik



- ▶ Werksnorm
- ▶ Schutzart IP 67
- ▶ großes LCD-Display
- ▶ digitale Skala (Segmentanzeige)
- ▶ 1 fester, 1 beweglicher Tastarm
- ▶ Messkontakte Hartmetall-Kugel
- ▶ Lieferung inkl. Werkskalibrierschein in Kartonbox

- ▶ Works standard
- ▶ Protection class IP 67
- ▶ Large LCD display
- ▶ Digital scale (segment display)
- ▶ 1 fixed and 1 movable arm
- ▶ Tungsten carbide contact balls
- ▶ Delivered incl. works calibration certificate in cardboard box

**Funktionen:**

- ▶ Ein/Aus
- ▶ mm/inch Umschaltung
- ▶ 0-Punkt an jeder Position
- ▶ ABS / Relativ Modus
- ▶ Skalenteilungswert umschaltbar 0,1 / 0,01mm
- ▶ Toleranzampel LED rot/grün
- ▶ Datenausgang

**Functions:**

- ▶ On/Off
- ▶ mm/inch commutation
- ▶ Zero setting at any position
- ▶ ABS / Relative mode
- ▶ Reversible scale interval 0.1 / 0.01mm
- ▶ Tolerance signal lights LED red/green
- ▶ Data output



No. 1351 106



No. 1351 301



No. 1351 208

**I** Kabellose Funk-Datenübertragung auf Anfrage.

**I** Wireless radio transmission on request.

**I** Andere Messbereiche, Tasterformen und Holzetuis auf Anfrage.

**I** Other measuring ranges, other probes and wooden boxes on request.

mm	<math>\leq</math> mm	mm	N	Taster probe $\varnothing$ mm	L mm	A mm	B mm	kg	N <sup>o</sup>	Datenkabel Data cable
0 - 10	0,005	0,015	0,8 - 1,2	1,5	35	18,6	19,1	0,30	1351 301	13506-*
0 - 20	0,01	0,03	1,1 - 1,6	1,5	85	24,6	24,6	0,35	1351 302	
0 - 30	0,02	0,04	0,9 - 1,6	3	116	30	30	0,43	1351 106	
0 - 50	0,02	0,06	0,8 - 1,7	3	167	30	30	0,49	1351 206	

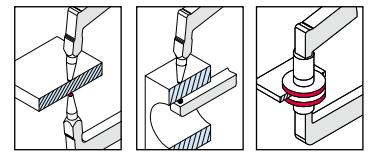

Kugel / Ball  $\varnothing$  1,5 / 3mm  
 Rohrwand / Pipe-wall  $\varnothing$  1,5 / 3mm  
 Teller / Disc  $\varnothing$  6 / 10mm

**Ausführung für Rohrwandmessung / Model for pipe-wall measurement**

0 - 10	0,005	0,015	0,8 - 1,2	1,5	35	0,9	19	0,35	1351 310	13506-*
0 - 20	0,01	0,03	1,1 - 1,6	1,5	85	2,5	24,6	0,35	1351 311	
0 - 30	0,02	0,04	0,9 - 1,6	3	116	4	30	0,41	1351 108	
0 - 50	0,02	0,06	0,8 - 1,7	3	169	4,3	30	0,46	1351 208	

**Ausführung mit Teller / Model with discs**

0 - 10	0,005	0,02	0,8 - 1,2	6	35	14,8	21,7	0,35	1351 401	13506-*
0 - 20	0,01	0,04	1,1 - 1,6	10	85	20,7	28,2	0,45	1351 403	

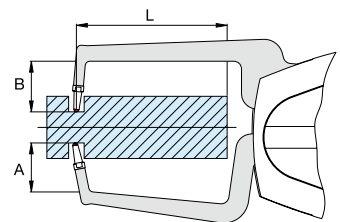

**\* Bestellhinweis für Datenkabel:**

Für Datenkabel bitte die gewünschte Ausführung (USB oder Digimatic) angeben.  
 Beispiel: Nr. 13506- mit USB = Nr. 13506-USB  
 Beispiel: Nr. 13506- mit Digimatic = Nr. 13506-DIGI

**\* Order advice for datacable:**

For data cable please mention the required version (USB or Digimatic).  
 Example: No. 13506- with USB = No. 13506-USB  
 Example: No. 13506- with Digimatic = No. 13506-DIGI

**Schnellfaster  
für Außenmessung**

**Dial caliper gauges  
for external measurement**

**Kroepelin**  
Längenmesstechnik



IP65

- ▶ Werksnorm
- ▶ Schutzart IP (siehe Tabelle)
- ▶ Toleranzmarken einstellbar
- ▶ 1 fester, 1 beweglicher Tastarm
- ▶ Messkontakte Hartmetall-Kugel
- ▶ Lieferung inkl. Werkskalibrierschein in Kartonbox

- ▶ Works standard
- ▶ Protection class IP (see table)
- ▶ Adjustable tolerance marks
- ▶ 1 fixed and 1 movable arm
- ▶ Tungsten carbide contact balls
- ▶ Delivered incl. works calibration certificate in cardboard box



No. 1353 502



No. 1353 503

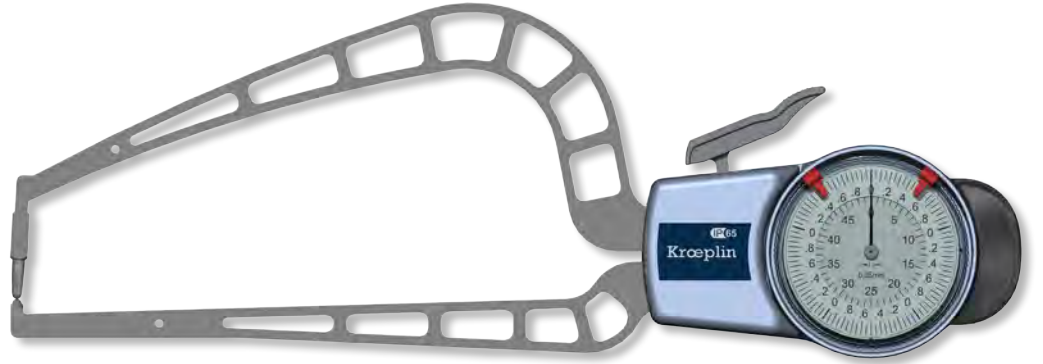

No. 1355 706

**I** Andere Messbereiche, Tasterformen und Holzetuis auf Anfrage.

**I** Other measuring ranges, other probes and wooden boxes on request.

mm	<math>\Delta</math> mm	mm	N	IP	Taster probe Ø mm	L mm	A mm	B mm	kg	Nº
0 – 10	0,1	0,1	0,3 – 1,3	-	2	36	5	5	0,04	1353 502
0 – 10	0,005	0,015	0,8 – 1,2	65	1,5	35	18,6	19,1	0,14	1355 200
0 – 20	0,01	0,03	1,1 – 1,6	65	1,5	85	24,6	24,6	0,3	1353 503
0 – 50	0,05	0,05	0,8 – 1,7	65	3	167	30	30	0,43	1353 506
50 – 100	0,05	0,075	0,8 – 1,7	65	3	167	30	23	0,45	1353 507
Ausführung für Rohrwandmessung / Model for pipe-wall measurement										
0 – 10	0,005	0,015	0,8 – 1,2	65	1,5	35	0,9	19,1	0,14	1355 702
0 – 20	0,01	0,03	1,1 – 1,6	65	1,5	85	2,5	24,6	0,3	1355 704
0 – 50	0,05	0,05	0,8 – 1,7	65	3	169	4,3	30	0,4	1355 706
Ausführung mit Teller / Model with discs										
0 – 10	0,005	0,02	0,8 – 1,2	65	6	35	14,8	21,7	0,35	1353 401
0 – 20	0,01	0,04	1,1 – 1,6	65	10	85	20,7	28,2	0,45	1353 403

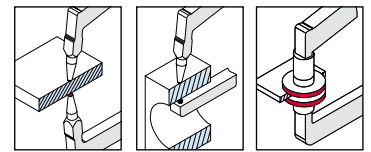

Kugel / Ball Ø 1,5 / 2 / 3mm  
Rohrwand / Pipe-wall Ø 1,5 / 3mm  
Teller / Disc Ø 6 / 10mm

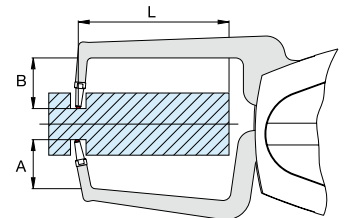

## Digital Schnelltaster für Innenmessung mit auswechselbaren Messtastern

## Digital dial caliper gauges for internal measurement with interchangeable probes



- ▶ Werksnorm
- ▶ Schutzart IP 54, Sylvac System
- ▶ großes LCD-Display
- ▶ 1 fester, 1 beweglicher Tastarm
- ▶ Voreinstellung mit Einstellringen oder Endmaßen
- ▶ Messtaster auswechselbar M2,5
- ▶ Lieferung im Etui inkl. 1 Paar Kugeltaster Ø 3,5mm

- ▶ Works standard
- ▶ Protection class IP 54, Sylvac system
- ▶ Large LCD display
- ▶ 1 fixed and 1 movable arm
- ▶ Pre-setting through setting gauges or gauge blocks
- ▶ Interchangeable measuring probes M2.5
- ▶ Delivered in case incl. 1 pair measuring ball probes Ø 3.5mm

### Funktionen:

- ▶ Ein/Aus
- ▶ mm/inch Umschaltung
- ▶ 0-Punkt an jeder Position
- ▶ ± Preset Funktion
- ▶ Datenausgang Opto

### Functions:

- ▶ On/Off
- ▶ mm/inch commutation
- ▶ Zero setting at any position
- ▶ ± Preset function
- ▶ Data output Opto

mm	≤ mm	mm	N	L mm	A mm	B mm	kg	Nº
22 - 114 / 25mm	0,01	0,02	5	50	4,5	3,5	0,3	1348 101
30 - 114 / 25mm	0,01	0,02	5	80	10	4,5	0,3	1348 102
30 - 114 / 25mm	0,01	0,02	5	120	12	4,5	0,35	1348 103
Datenkabel RS232 (2m) / Data cable RS232 (2m)								1850 203
Datenkabel USB (2m) / Data cable USB (2m)								1850 204

Messbereichserweiterung durch zusätzliche Messuhrverlängerung Nr. 1330 1.. möglich siehe Gesamtkatalog Seite 4.15  
 Measuring range extension through additional dial gauge extension no. 1330 1.. see main catalogue page 4.15

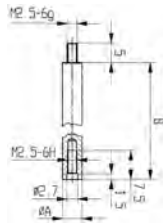

Messeinsätze M 2,5, siehe Gesamtkatalog Seite 4.16  
 Measuring inserts M 2.5, see main catalogue page 4.16

Messweg 25mm  
 Measuring way 25mm

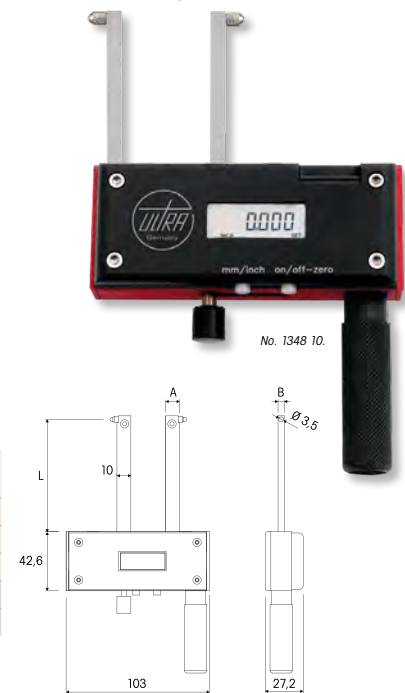

## Digital Schnelltaster für Außenmessung mit auswechselbaren Messtastern

## Digital dial caliper gauges for external measurement with interchangeable probes



- ▶ Werksnorm
- ▶ Schutzart IP 54, Sylvac System
- ▶ großes LCD-Display
- ▶ 1 fester, 1 beweglicher Tastarm
- ▶ Messtaster auswechselbar M2,5
- ▶ Lieferung im Etui inkl. 1 Paar Kugeltastern Ø 3,5mm

- ▶ Works standard
- ▶ Protection class IP 54, Sylvac system
- ▶ Large LCD display
- ▶ 1 fixed and 1 movable arm
- ▶ Interchangeable measuring probes M2.5
- ▶ Delivered in case incl. 1 pair measuring ball probes Ø 3.5mm

### Funktionen:

- ▶ Ein/Aus
- ▶ mm/inch Umschaltung
- ▶ 0-Punkt an jeder Position
- ▶ ± Preset Funktion
- ▶ Datenausgang Opto

### Functions:

- ▶ On/Off
- ▶ mm/inch commutation
- ▶ Zero setting at any position
- ▶ ± Preset function
- ▶ Data output Opto

mm	≤ mm	mm	N	L mm	A mm	B mm	kg	Nº
0 - 22 / 25mm	0,01	0,02	5	50	4,5	3,5	0,3	1349 101
0 - 24 / 25mm	0,01	0,02	5	80	10	4,5	0,3	1349 103
0 - 24 / 25mm	0,01	0,02	5	120	12	4,5	0,35	1349 105
19 - 44 / 25mm	0,01	0,02	5	50	4,5	3,5	0,3	1949 102
0 - 69 / 25mm	0,01	0,02	5	80	10	4,5	0,3	1949 104
0 - 69 / 25mm	0,01	0,02	5	120	12	4,5	0,35	1949 106
Datenkabel RS232 (2m) / Data cable RS232 (2m)								1850 203
Datenkabel USB (2m) / Data cable USB (2m)								1850 204

Datenkabel RS232 (2m) / Data cable RS232 (2m)

Datenkabel USB (2m) / Data cable USB (2m)

Messeinsätze M 2,5, siehe Gesamtkatalog Seite 4.16  
 Measuring inserts M 2.5, see main catalogue page 4.16

Messweg 25mm  
 Measuring way 25mm

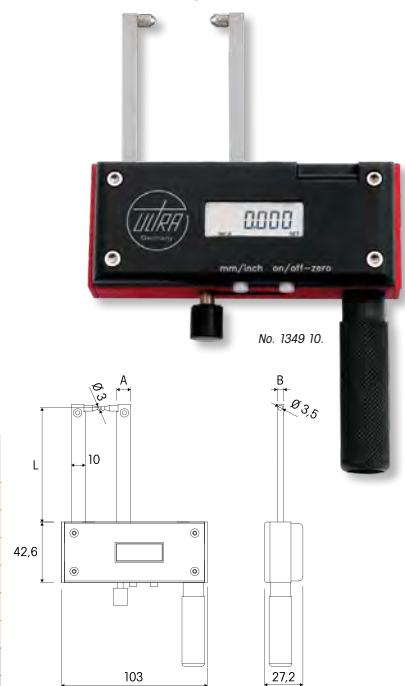

**Messtisch für Schnelltaster  
Nr. 1348 1.. und 1349 1..**

**Measuring table for dial caliper gauges  
No. 1348 1.. and 1349 1..**



- ▶ Messfläche aus rostfreiem, gehärtetem Stahl
- ▶ Lieferung einzeln verpackt, ohne Schnelltaster

- ▶ Hardened measuring surfaces made of stainless steel
- ▶ Delivered in individual packages without dial caliper gauge

■ mm	⚖ kg	№
145x60	1,25	1348 991



No. 1348 991

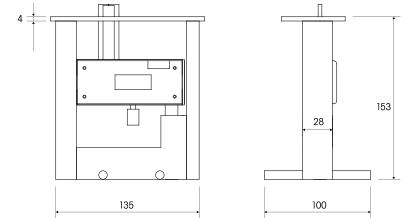

**Digital-Messschieber, Nutsymmetriemessgerät  
für Nutmittenabstandsmessung**

**Digital calipers  
for slot center distance measuring**



- ▶ Werksnorm
- ▶ für Wellendurchmesser ≤120mm
- ▶ Feststellschraube
- ▶ rostfreier Stahl gehärtet
- ▶ großes LCD-Display
- ▶ 2 bewegliche Tastarme
- ▶ Lieferung im Etui

- ▶ Works standard
- ▶ for shaft diameter ≤120mm
- ▶ Locking screw
- ▶ Hardened stainless steel
- ▶ Large LCD display
- ▶ 2 moveable arms
- ▶ Delivered in individual packages

**Funktionen:**

- ▶ Ein/Aus
- ▶ mm/inch Umschaltung
- ▶ 0-Punkt an jeder Position
- ▶ ABS Funktion (fester 0-Punkt)

**Funktionen:**

- ▶ On/Off
- ▶ mm/inch commutation
- ▶ Zero setting at any position
- ▶ ABS function (fixed 0 point)



No. 1850 651

↙ links/left		↘ rechts/right		↔ mm	⚖ kg	№
mm	inch	mm	inch			
0 - 40	0 - 1,6	0 - 70	0 - 2.8	0,01	0,5	1850 651

**Digital Schnelltaster  
für Nutmittenabstandsmessung**

**Digital dial caliper gauges  
for slot center distance measuring**



- ▶ Werksnorm
- ▶ Schutzart IP 54, Sylvac System
- ▶ großes LCD-Display
- ▶ 1 fester Tastarm für auswechselbare Nutsteine,  
1 beweglicher Tastarm
- ▶ Lieferung im Etui ohne Nutstein

- ▶ Works standard
- ▶ Protection class IP 54, Sylvac system
- ▶ Large LCD display
- ▶ 1 fixed arm for interchangeable sliding blocks  
and 1 movable arm
- ▶ Delivered in case without sliding blocks

**Funktionen:**

- ▶ Ein/Aus
- ▶ mm/inch Umschaltung
- ▶ 0-Punkt an jeder Position
- ▶ ± Preset Funktion
- ▶ Datenausgang Opto

**Funktionen:**

- ▶ On/Off
- ▶ mm/inch commutation
- ▶ Zero setting at any position
- ▶ ± Preset function
- ▶ Data output Opto

! Bei Bestellung von Nr. 1347 351 Nutbreite (4-20mm) angeben

! Specify slot width (4-20mm) in case of order no. 1347 351

↔ mm	↔ mm	⊙ mm	⬇ N	A mm	B mm	⚖ kg	№
8 - 58	0,01	0,02	5	29	4	0,4	1347 301
50 - 100	0,01	0,02	5	50	25	0,4	1347 302
1 Stück Nutstein 4-20mm / 1 pcs. Key slot 4-20mm							1347 351
Datenkabel RS232 (2m) / Data cable RS232 (2m)							1850 203
Datenkabel USB (2m) / Data cable USB (2m)							1850 204



No. 1347 30.

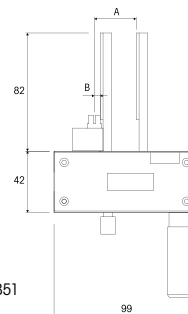

**Dickenmessgeräte für Rohrwandmessung**

**Thickness gauges for pipe-wall measurement**



- ▶ Werksnorm
- ▶ Bügel aus Metall
- ▶ Außenring Ø 58mm
- ▶ Messbolzen Ø 6mm, Bund mit Radius 1mm
- ▶ Messkontakte in Ruhestellung geschlossen
- ▶ mit Abhebevorrichtung
- ▶ Lieferung in Kartonbox

- ▶ Works standard
- ▶ Metal throat
- ▶ Outer ring Ø 58mm
- ▶ Inserts Ø 6mm, collar with 1mm radius
- ▶ Closed contacts when not in use
- ▶ with lifting device
- ▶ Delivered in cardboard box

**1364 101 :**  
Analogablesung

**1364 101 :**  
Analogue reading

**1364 201 :**  
Digitalablesung mit Datenausgang Proximity  
(Funktion siehe S. 6.8)

**1364 201 :**  
Digital reading with data output Proximity  
(Function see p. 6.8)



mm	mm	mm	mm	kg	Nº
0 - 10	0,01	50	1	0,4	1364 101
0 - 10	0,01	50	-	0,4	1364 201

**Sägeschränk Messuhr**

**Saw setting dial gauges**



- ▶ Werksnorm
- ▶ doppelseitig ablesbar
- ▶ Gehäuse aus Metall
- ▶ 4 Auflagepunkte
- ▶ Außenring Ø 40mm
- ▶ Toleranzmarken einstellbar
- ▶ Lieferung in Kartonbox

- ▶ Works standard
- ▶ Double-side reading
- ▶ Metal housing
- ▶ 4 bearing points
- ▶ Outer ring Ø 40mm
- ▶ Adjustable tolerance marks
- ▶ Delivered in cardboard box

**1338 1.. / 1338 2.. :**  
Taster und Auflagepunkte Stahl gehärtet

**1338 1.. / 1338 2.. :**  
Inserts and bearing points, hardened steel

**1338 601 :**  
Taster und Auflagepunkte hartmetallbestückt

**1338 601 :**  
Inserts and bearing points, tungsten carbide tipped

! Zollablesung sowie spitzer oder kugeliger Messeinsatz auf Anfrage.

! Inch reading and pointed or ball inserts on request.

mm	mm	Taster / Probe Ø mm	kg	Nº
0 - 2	0,1/0,05	10	0,2	1338 101
0 - 2	0,1/0,05	4,8	0,2	1338 201
0 - 2	0,1/0,05	10	0,2	1338 601



Taster und Auflagepunkte hartmetallbestückt  
Inserts and bearing points, tungsten carbide tipped

**Dickenmessgeräte STANDARD**

**Thickness gauges, STANDARD**



- ▶ Werksnorm
- ▶ Ablesung cm an der Taststange
- ▶ Bügel aus Metall
- ▶ Außenring Ø 40mm (Nr. 1359 104 = Ø 58mm)
- ▶ Messkontakte in Ruhestellung offen
- ▶ Lieferung in Kartonbox

- ▶ Works standard
- ▶ Reading (cm) on probe shaft
- ▶ Metal frame
- ▶ Outer ring Ø 40mm (No. 1359 104 = Ø 58mm)
- ▶ Open contacts when not in use
- ▶ Delivered in cardboard box

! Größere Messbereiche und Bügeltiefen auf Anfrage.

! Larger measuring ranges and throat depths on request.

mm	mm	mm	Taster / Probe Ø mm	kg	Nº
0 - 10	0,1	20	10	0,05	1359 101
0 - 20	0,1	20	10	0,08	1359 102
0 - 20	0,1	50	10	0,1	1359 103
0 - 30	0,1	50	10	0,15	1359 104



## Dickenmessgeräte im Taschenformat

## Thickness gauges, pocket size



- ▶ Werksnorm
- ▶ Gehäuse aus Metall
- ▶ Außenring Ø 40mm
- ▶ Lieferung im Etui

- ▶ Works standard
- ▶ Metal housing
- ▶ Outer ring Ø 40mm
- ▶ Delivered in a case

! Bei Bestellung Messkontakt Form angeben – als Standard wird Form F geliefert. Nr. 1360 102 nur mit Messkontakt E oder F.

! Specify contact type in order – standard supply with type F. No. 1360 102 only with contact type E or F.

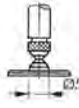
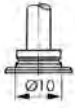

No. 1360 101



No. 1360 102



No. 1360 201

mm	mm	mm	mm	kg	Nº
Messkontakte in Ruhestellung offen / Open contacts when not in use					
0 – 10	0,1	15	10	0,07	1360 101
0 – 20	0,1	15	10	0,08	1360 201
Messkontakte in Ruhestellung geschlossen / Closed contacts when not in use					
0 – 8	0,01	12	1	0,07	1360 102
0 – 10	0,01	18	1	0,13	1360 103
0 – 10	0,01	45	1	0,15	1360 104

## Digital-Dickenmessgeräte

## Digital thickness gauges



Sylvac System

- ▶ Werksnorm
- ▶ Sylvac System
- ▶ großes LCD-Display, um 270° drehbar
- ▶ Bügel aus Metall
- ▶ Außenring Ø 60mm
- ▶ Messkontakte in Ruhestellung geschlossen
- ▶ mit Abhebevorrichtung
- ▶ Lieferung im Etui

- ▶ Works standard
- ▶ Sylvac System
- ▶ Large LCD display, turnable through 270°
- ▶ Metal frame
- ▶ Outer ring Ø 60mm
- ▶ Closed contacts when not in use
- ▶ with lifting device
- ▶ Delivered in a case

- Funktionen:**
- ▶ Ein/Aus
  - ▶ mm/inch Umschaltung
  - ▶ 0-Punkt an jeder Position
  - ▶ Hold Funktion
  - ▶ ± Preset Funktion
  - ▶ Datenausgang Proximity

- Functions:**
- ▶ On/Off
  - ▶ mm/inch commutation
  - ▶ Zero setting at any position
  - ▶ Hold function
  - ▶ ± Preset function
  - ▶ Data output Proximity

! Bei Bestellung Messkontakt Form angeben – als Standard wird Form C geliefert.

! Specify contact type in order – standard supply with type C.

! Sondergeräte auf Anfrage.

! Special gauges on request.

mm	inch	mm	inch	mm	N	kg	Nº
0 – 10	0 – .393	0,01	.0005	50	0,8	0,5	1361 201
0 – 10	0 – .393	0,01	.0005	100	0,8	0,6	1361 202
0 – 25	0 – .984	0,01	.0005	100	1,0	0,6	1361 204
0 – 25	0 – .984	0,01	.0005	200	1,2	1,4	1361 205
0 – 10	0 – .393	0,001	.00005	50	0,8	0,5	1361 206
0 – 25	0 – .984	0,001	.00005	100	1,0	0,6	1361 207
Datenkabel / Data cable RS232 (2m)							1850 203ip
Datenkabel / Data cable USB (2m)							1850 204ip



No. 1361 201



No. 1361 206

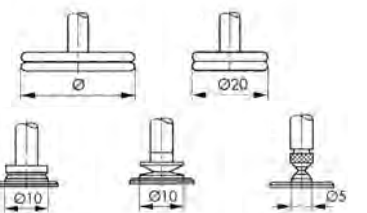



**Dickenmessgeräte**

**Thickness gauges**



- ▶ Werksnorm
- ▶ Bügel aus Metall
- ▶ Außenring Ø 58mm
- ▶ mit Abhebevorrichtung
- ▶ Lieferung im Etui

- ▶ Works standard
- ▶ Metal frame
- ▶ Outer ring Ø 58mm
- ▶ With lifting device
- ▶ Delivered in case

**!** Bei Bestellung Messkontakt Form angeben – als Standard wird Form C geliefert.

**!** Specify contact type in order – standard supply with type C.

**!** Sondergeräte, sowie reduzierte oder erhöhte Messkraft auf Anfrage.

**!** Special gauges and models with reduced or increased measuring forces on request.

mm	mm	mm	mm	N	kg	Nº
Messkontakte in Ruhestellung offen / Open contacts when not in use						
0 – 10	0,1	50	10	-	0,2	1361 101
0 – 20	0,1	50	10	-	0,25	1361 103
0 – 30	0,1	50	10	-	0,30	1361 104
0 – 30	0,1	100	10	-	0,35	1361 105
0 – 50	0,1	50	10	-	0,35	1361 109
0 – 10	0,01	50	1	-	0,25	1361 110
Messkontakte in Ruhestellung geschlossen / Closed contacts when not in use						
0 – 10	0,1	50	10	0,5	0,2	1361 102
0 – 30	0,1	200	10	1,8	0,6	1361 106
0 – 30	0,1	300	10	1,8	0,9	1361 107
0 – 30	0,1	400	10	1,8	1,2	1361 108
0 – 10	0,01	50	1	0,8	0,25	1361 111
0 – 10	0,01	100	1	0,8	0,4	1361 112
0 – 10	0,01	200	1	1,5	0,9	1361 113
0 – 30	0,01	200	1	1,5	0,9	1361 114

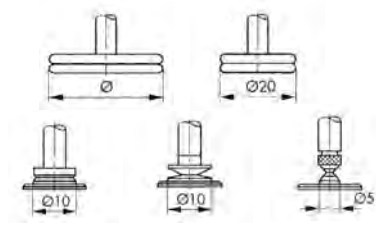
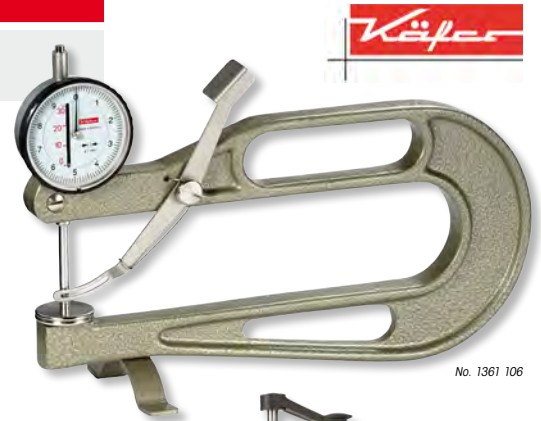

**Dickenmessgeräte mit großem Bügel**

**Thickness gauges with large frames**



- ▶ Werksnorm
- ▶ Bügel aus Metall
- ▶ Außenring Ø 58mm
- ▶ mit Abhebevorrichtung
- ▶ mit Standfuß
- ▶ Messkontakte in Ruhestellung geschlossen
- ▶ Lieferung einzeln verpackt, inkl. Standfuß

- ▶ Works standard
- ▶ Metal frame
- ▶ Outer ring Ø 58mm
- ▶ With lifting device
- ▶ With mounting stand
- ▶ Closed contacts when not in use
- ▶ Delivered in individual packages, incl. mounting stand

**!** Bei Bestellung Messkontaktform angeben.

**!** Specify contact type in order.

**!** Digitalablesung sowie reduzierte oder erhöhte Messkraft auf Anfrage.

**!** Digital reading and models with reduced or increase measuring forces on request.

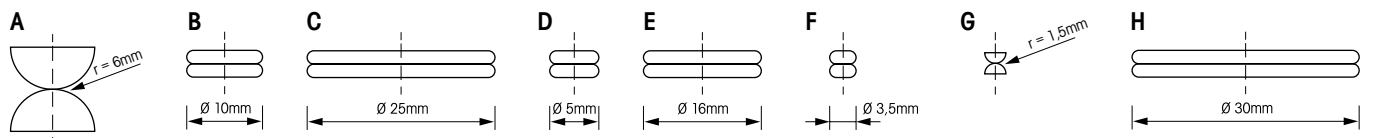

mm	mm	mm	mm	N	kg	Nº
0 – 25	0,1	300	10	2-3	0,9	1365 101
0 – 25	0,1	500	10	2-3	1,9	1365 102
0 – 25	0,1	650	10	2-3	4,1	1365 103
0 – 50	0,1	300	10	2-4	1,1	1365 104
0 – 50	0,1	500	10	2-4	2,0	1365 105
0 – 50	0,1	650	10	2-4	4,3	1365 106
0 – 75	0,1	350	10	2-4	1,1	1365 107
0 – 100	0,1	400	10	2-4	2,2	1365 108

## Dickenmessgeräte für dünne Folien

## Thickness gauges for thin films



- ▶ Werksnorm
- ▶ Stoßschutz
- ▶ Bügel aus Metall mit Isoliergriff
- ▶ Messkontakte Ø 6,35mm
- ▶ Messkontakte in Ruhestellung geschlossen
- ▶ mit Abhebevorrichtung
- ▶ Lieferung im Etui

- ▶ Works standard
- ▶ Shockproof
- ▶ Metal frame with insulated handle
- ▶ Contacts Ø 6.35mm
- ▶ Closed contacts when not in use
- ▶ With lifting device
- ▶ Delivered in case

**1362 101 / 1362 201 :**  
Analogablesung

**1362 101 / 1362 201 :**  
Analogue reading

**1362 301 :**  
Digitalablesung mit Datenausgang Opto  
(Funktionen siehe S. 6.10)

**1362 301 :**  
Digital reading with data output Opto  
(Functions see page 6.10)

**I** Andere Messeinsätze sowie erhöhte oder reduzierte Messkraft auf Anfrage.

**I** Other inserts and models with reduced or increased measuring force on request.

mm	<math>\leq</math> mm	mm	mm	N	mm	kg	Nº
0 - 1	0,001	30	0,1	1,5	0,005	0,4	1362 101
0 - 0,1	0,001	30	0,1	1,5	0,0015	0,4	1362 201
0 - 3	0,001	30	-	2	0,003	0,57	1362 301



## Standfuß für Dickenmessgeräte

## Mounting stand for thickness gauges



- ▶ passend für alle digitale und analoge Geräte Nr. 1361 ... mit Bügeltiefe 50 oder 100mm
- ▶ Lieferung einzeln verpackt

- ▶ Suitable for all digital and analogue devices No. 1361 ... with 50 or 100mm throat depth
- ▶ Delivered in individual packages

mm	kg	Nº
100x30x19	0,2	1361 301



## Dickenmessgeräte mit Messrollen

## Thickness gauges with measuring rollers



- ▶ Werksnorm
- ▶ Bügel aus Metall
- ▶ Messrollen Ø 8,4mm, Breite 8,7mm
- ▶ Messkontakte in Ruhestellung geschlossen
- ▶ mit Abhebevorrichtung
- ▶ Lieferung im Etui

- ▶ Works standard
- ▶ Metal frame
- ▶ Rollers Ø 8.4mm, width 8.7mm
- ▶ Closed contacts when not in use
- ▶ With lifting device
- ▶ Delivered in a case

**1363 1..:**  
Analogablesung

**1363 1..:**  
Analogue reading

**1363 2.. :**  
Digitalablesung mit Datenausgang Proximity  
(Funktionen siehe S. 6.10)

**1363 2.. :**  
Digital reading with data output Proximity  
(Functions see page 6.10)

**I** Ablesung 0,1mm oder 0,001mm auf Anfrage.

**I** 0.1 mm or 0.001 mm readings on request.

mm	<math>\leq</math> mm	mm	mm	N	kg	Nº
mit Seitenscheiben / Rollers with side discs						
0 - 5	0,01	50	1	1,2	0,3	1363 101
0 - 10	0,01	50	-	1,2	0,3	1363 201
ohne Seitenscheiben / Rollers without side discs						
0 - 5	0,01	50	1	1,2	0,3	1363 102
0 - 10	0,01	50	-	1,2	0,3	1363 202



**Digital-Tiefenmessgeräte**

**Digital depth gauges**

 **Sylvac System**

- ▶ Werksnorm
- ▶ Sylvac System
- ▶ großes LCD-Display, um 270° drehbar
- ▶ Außenring Ø 60mm
- ▶ Messfläche gehärtet, DIN 876/0
- ▶ Lieferung im Etui

**Funktionen:**

- ▶ Ein/Aus
- ▶ mm/inch Umschaltung
- ▶ 0-Punkt an jeder Position
- ▶ Hold Funktion
- ▶ ± Preset Funktion
- ▶ Datenausgang Proximity

- ▶ Works standard
- ▶ Sylvac System
- ▶ Large LCD display, turnable through 270°
- ▶ Outer ring Ø 60mm
- ▶ Hardened measuring face, DIN 876/0
- ▶ Delivered in a case

**Functions:**

- ▶ On/Off
- ▶ mm/inch commutation
- ▶ Zero setting at any position
- ▶ Hold function
- ▶ ± Preset function
- ▶ Data output Proximity

! Größere Messspanne oder Messbrücke auf Anfrage.

! Larger measuring ranges and bridges on request.

mm	inch	≤ mm	mm	kg	Nº	
0 – 12,5	0 – .5	0,01	.0005	80x16	0,3	1368 201
0 – 25	0 – 1	0,01	.0005	80x16	0,4	1368 202
> 25mm auf Anfrage / on request						
Datenkabel / Data cable RS232 (2m)					1850 203ip	
Datenkabel / Data cable USB (2m)					1850 204ip	



No. 1368 201

**Tiefenmessgeräte**

**Dial depth gauges**



- ▶ Werksnorm
- ▶ Außenring Ø 58mm
- ▶ Messfläche gehärtet, DIN 876/0
- ▶ Lieferung im Etui

- ▶ Works standard
- ▶ Outer ring Ø 58mm
- ▶ Hardened measuring face, DIN 876/0
- ▶ Delivered in a case

! Größere Messspanne oder Messbrücke auf Anfrage.

! Larger measuring ranges and bridges on request.

mm	≤ mm	mm	kg	Nº
0 – 10	0,01	80x16	0,4	1368 101
0 – 30	0,01	80x16	0,5	1368 102
0 – 50	0,01	80x16	0,6	1368 103
0 – 100 (10)	0,01	80x16	0,6	1369 101
> 100mm auf Anfrage / on request				



No. 1368 101

No. 1368 102

**Tiefenmessbrücken**

**Depth measuring bridges**



- ▶ Messfläche gehärtet, DIN 876/0
- ▶ Messuhraufnahme Ø 8mm
- ▶ Lieferung einzeln verpackt

- ▶ Hardened measuring faces DIN 876/0
- ▶ Dial mounting hole Ø 8mm
- ▶ Delivered in individual packages

mm	kg	Nº	mm	kg	Nº
50x16	0,18	1370 201	120x20	0,25	1370 203
80x16	0,2	1370 202	150x20	0,3	1370 205
100x16	0,23	1370 204			



No. 1370 205

No. 1370 202

## Tiefenmessgeräte mit verstellbarer Messnadel

## Dial depth gauges with adjustable needle



- ▶ Werksnorm
- ▶ Messweg Messuhr 30mm
- ▶ Außenring Ø 58mm
- ▶ Messnadel Ø 2mm
- ▶ Messfläche gehärtet
- ▶ Lieferung im Etui

- ▶ Works standard
- ▶ Gauge measuring range 30mm
- ▶ Outer ring Ø 58mm
- ▶ Pointer Ø 2mm
- ▶ Hardened measuring face
- ▶ Delivered in a case



No. 1370 101

mm	mm	mm	kg	Nº
0 - 200	0,01	50x16	0,4	1370 101

## Digital-Innenfeinmessdorne MICROGAUGE, Sätze

## Digital precision bore gauges MICROGAUGE, Sets



**BOWERS GROUP**

- ▶ Werksnorm
- ▶ Schutzart IP 65, Sylvac System
- ▶ großes LCD-Display
- ▶ Tastköpfe austauschbar
- ▶ Taster hartverchromt
- ▶ Wiederholbarkeit der Messwerte 0,001mm
- ▶ Lieferung im Holzetui inkl. Tiefenanschläge und Einstellringen mit UKAS-Kalibrierscheine

- ▶ Works standard
- ▶ Protection class IP 65, Sylvac System
- ▶ Large LCD display
- ▶ Interchangeable probe tips
- ▶ Hard chrome-plated probes
- ▶ Repeatability of measuring values 0.001mm
- ▶ Delivered in wooden box incl. depth stops and setting gauges incl. UKAS calibration certificates

### Funktionen:

- ▶ Ein/Aus
- ▶ mm/inch Umschaltung
- ▶ Ablesung umschaltbar 0,01/0,001/0,0005mm
- ▶ Datenausgang Proximity

### Functions:

- ▶ On/Off
- ▶ mm/inch cummutation
- ▶ Reversible reading 0.01/0.001/0.0005mm
- ▶ Data output Proximity



No. 1378 50.



No. 1378 50.



No. 1161 521

! Einzelgeräte oder andere Satzzusammenstellungen auf Anfrage.

! Individual devices or other set compositions on request.

mm	mm	Taster / Stück Probes / Pieces	kg	Nº
0,95 - 1,55	0,6 - 11	5	0,8	1378 501
1,50 - 2,45	0,9 - 17	3	0,9	1378 502
2,25 - 4,25	1,2 - 22	7	1,1	1378 503
3,65 - 6,35	2 - 40	5	1,2	1378 504
6,15 - 10,35	2 - 40 / 50	8	1,8	1378 505
<b>Große Sätze / Large Sets</b>				
0,95 - 2,45	0,6 - 11 / 0,9 - 17	8	1,2	1378 506
1,50 - 4,25	0,9 - 17 / 1,2 - 22	10	1,7	1378 507
2,25 - 6,35	1,2 - 22 / 2 - 40	12	1,8	1378 508
Halter für Digital-Innenfeinmessdorne MICROGAUGE / Holder for digital precision bore gauge MICROGAUGE				1161 521
Datenkabel RS 232 (2m) / Data cable RS 232 (2m)				1850 203
Datenkabel USB (2m) / Data cable USB (2m)				1850 204

**OSIMESS Innenfeinmessgeräte**

**OSIMESS precision bore gauges**



- ▶ Werksnorm
- ▶ Tastköpfe auswechselbar
- ▶ Taster 1 – 4mm hartmetallbestückt, > 4mm hartverchromt
- ▶ Messnadel aus Hartmetall
- ▶ Messuhraufnahme Ø 8mm
- ▶ Wiederholbarkeit der Messwerte <1µm
- ▶ Lieferung im Holzetui, ohne Messuhr, ohne Einstellringe

- ▶ Works standard
- ▶ Interchangeable probe tips
- ▶ Tungsten carbide-tipped probes for sizes 1 – 4 mm; > 4 mm hard chrome-plated
- ▶ Tungsten carbide gauge pins
- ▶ Dial mounting hole Ø 8mm
- ▶ Repeatability of measuring values <1µm
- ▶ Delivered in wooden box without dial gauge or setting rings



No. 1378 103

**1378 1.. :**

Halter ohne Rückholknopf

**1378 1.. :**

Holder without return button

**1379 1.. :**

Halter mit Rückholknopf

**1379 1.. :**

Holder with return button

**1380 1.. :**

Satz Einstellringe

**1380 1.. :**

Setting ring set

**!** Einzelgeräte, Tastköpfe für Nuten oder Sacklochbohrungen auf Anfrage.

**!** Individual devices and probe tips for slots or blind holes on request.

mm	mm	Taster / Stück Probes / Pieces	kg	Nº	Nº	Nº
0,47 – 0,97	1,5 – 3	6	1,4	-	1379 101	1380 101
0,95 – 4,2	13 – 25	15	1,6	1378 102	1379 102	1380 102
4,15 – 12,3	41 – 45	13	1,8	1378 103	1379 103	1380 103
12,2 – 20,6	45	8	2,0	1378 104	1379 104	1380 104

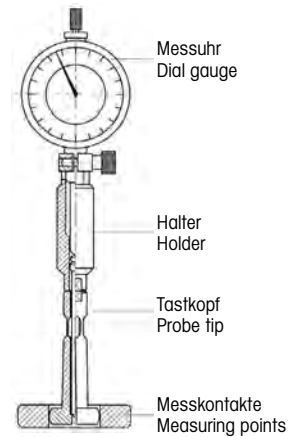

**OSIMESS Zubehör**

**OSIMESS accessories**



- ▶ Lieferung einzeln verpackt

- ▶ Delivered in individual packages

Typ Type	mm	kg	Nº
Halter ohne Rückholknopf / Holder without return button	-	0,1	1378 401
Halter mit Rückholknopf / Holder with return button	-	0,1	1379 401
Winkelstück 90° / Angle piece 90°	-	0,1	1380 401
Verlängerung / Extension	50	0,1	1380 601
Verlängerung / Extension	100	0,1	1380 602
Verlängerung / Extension	250	0,2	1380 603

Tastköpfe für Nutmessung auf Anfrage.  
Probe for slots on request.



No. 1379 401

No. 1380 401

**OSIMESS Messtisch für Serienkontrolle**

**OSIMESS comparator table for series inspection**



- ▶ Zahnstangenantrieb mit Handhebel
- ▶ Arbeitshub 90mm
- ▶ Tiefenmesseinrichtung
- ▶ Suche des Umkehrpunkts entfällt
- ▶ Lieferung einzeln verpackt ohne Messuhr

- ▶ Gear rack drive with lever
- ▶ Power stroke 90mm
- ▶ Depth measuring mechanism
- ▶ No search for turning point
- ▶ Delivered in individual packages without dial gauge

**!** schwimmende Werkstückauflage sowie Messwegbegrenzer auf Anfrage.

**!** Floating workpiece support and range limiter on request.

mm	mm	mm	Werkstück / workpiece max. Ø mm	kg	Nº
225x120x410	0 – 250	120	200	5,8	1380 501



No. 1380 501

## OD Bohrungsmessdorne

## OD bore gauges



- ▶ Werksnorm
- ▶ Zweipunkt-Vergleichsmessgeräte
- ▶ Messhülse verhindert Kippfehler
- ▶ Suche des Umkehrpunkts entfällt
- ▶ Taster hartmetallbestückt ~ 1600V
- ▶ Messnadel aus Hartmetall
- ▶ Messweg 0,2mm
- ▶ Anschlussgewinde M11x0,75 (M10x1 auf Anfrage)
- ▶ Messuhraufnahme Ø 8mm
- ▶ Wiederholbarkeit der Messwerte <1µm
- ▶ Lieferung einzeln verpackt ohne Messuhr, Griff und Einstellringe

- ▶ Works standard
- ▶ Two-point comparative measuring instrument
- ▶ Tilt-preventing measuring sleeve
- ▶ No search for turning point
- ▶ Tungsten carbide-tipped contact points ~ 1600V
- ▶ Tungsten carbide-tipped gauge pin
- ▶ Measuring range 0.2mm
- ▶ Mounting thread M11x0.75 (M10x1 on request)
- ▶ Dial mounting hole Ø 8mm
- ▶ Repeatability of measuring values <1µm
- ▶ Delivered in individual packages without dial gauge, handle and setting rings



OD Messring für Außen-durchmesser auf Anfrage.  
OD measuring ring for outer diameter on request.

### Typ A :

Standard-Hülse

### Typ A :

Standard sleeve

### Typ B :

Hülse für Durchgangsbohrung  
No. 3010 0002: Ø 6,1 – 9,0mm: h=6mm  
No. 3010 0002: Ø 9,0 – 12,0mm: h=10mm

### Typ B :

Sleeve for through bores  
No. 3010 0002: Ø 6.1 – 9.0mm: h=6mm  
No. 3010 0002: Ø 9.0 – 12.0mm: h=10mm

### Typ C :

Hülse für Sacklochbohrung

### Typ C :

Sleeve for blind bores

! Bei Bestellung bitte Bohrungsdurchmesser und Toleranz angeben, z.B. 12 H7 oder 12 +0,15/-0 Einstellringe DIN 2250C müssen separat bestellt werden.

! Specify bore diameter and tolerance in order, e.g. 12 H7 or 12 + 0, 15/-0 setting rings DIN 2250C must be separately ordered.

! Größere Durchmesser, hartverchromte Hülsen, Messkontakte aus Rubin, Delrin oder Keramik sowie Dreipunktausführung auf Anfrage, für weitere Details bitte technische Dokumentation anfordern.

! Larger diameters, chrome plated sleeves, contacts made of ruby, Delrin or ceramic, and three-point model on request; for further details, ask for technical documentation.

Kreuzkufenhülse auf Anfrage.  
Cross sleeve on request.

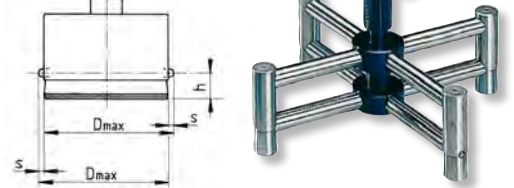

Ø mm	h mm	Typ A №	h mm	Typ B №	h mm	Typ C №	Ø mm	h mm	Typ A №	h mm	Typ B №	h mm	Typ C №
2,5 – 6	1,5	3000 0000	6	3000 0002	1	3000 0001	30,1 – 40	3,5	3040 0000	10	3040 0002	1,2	3040 0001
6,1 – 12	2,5	3010 0000	6/10	3010 0002	1	3010 0001	40,1 – 60	3,5	3050 0000	10	3050 0002	1,2	3050 0001
12,1 – 20	2,5	3020 0000	10	3020 0002	1	3020 0001	60,1 – 80	4,0	3060 0000	10	3060 0002	1,2	3060 0001
20,1 – 30	3,5	3030 0000	10	3030 0002	1,2	3030 0001	80,1 – 100	4,0	3070 0000	10	3070 0002	1,2	3070 0001

> Ø 100mm auf Anfrage / on request

## OD Gerätehalter

## OD equipment holder



▶ Lieferung einzeln verpackt

▶ Delivered in individual packages

Gerätehalter Typ / Holder Type	l mm	kg	№
für hohe Genauigkeit / For high accuracy	50	0,1	3200 0000
Standard / Standard	105	0,15	3200 0001
für tiefe Bohrungen / For deep holes	235	0,25	3200 0002
für elektronische Taster / For electronic probe	110	0,15	3200 0004
mit Rückholknopf (Sacklochhülsen) / With return button (blind hole sleeve)	70	0,1	3200 0042



No. 3200 0002

No. 3200 0004

No. 3200 0001

No. 3200 0000

## OD Messtiefenverlängerungen

## OD measuring depth extensions



▶ Lieferung einzeln verpackt

▶ Delivered in individual packages

für / for Ø mm	l mm	kg	№	für / for Ø mm	l mm	kg	№	für / for Ø mm	l mm	kg	№
4,0 – 6,5	50	0,01	3230 0100	6,5 – 12	50	0,04	3230 0110	>12	100	0,1	3230 0000
4,0 – 6,5	100	0,02	3230 0101	6,6 – 12	100	0,04	3230 0111	>12	250	0,25	3230 0001
4,0 – 6,5	250	0,03	3230 0103	6,6 – 12	150	0,04	3230 0112	>12	500	0,5	3230 0002



No. 3230 0001

No. 3230 0000

## OD Messiefenanschlag

## OD depth stop



► Lieferung einzeln verpackt

► Delivered in individual packages

! Stellung, Klemmung auf Hülse.  
Bitte Hüsendurchmesser angeben.

! Ring, clamping on sleeve.  
Please indicate sleeve diameter.

Typ Type	für / for Ø mm	kg	Nº
Stellung / Ring	3 – 40	0,2	3220 0000
Stellung / Ring	40,1 – 60	0,3	3220 0001
Brücke / Bridge	3 – 50	0,2	3220 0007
Brücke / Bridge	50,1 – 80	0,4	3220 0008
Brücke / Bridge	80,1 – 100	0,5	3220 0009
3-Punkt / 3-point	30 – 50	0,2	3220 0019
3-Punkt / 3-point	50,1 – 80	0,3	3220 0020
3-Punkt / 3-point	80,1 – 100	0,4	3220 0021
3-Punkt / 3-point	100,1 – 150	0,6	3220 0022



## SU Innenfeinmessgeräte, Präzisionsausführung

## SU bore gauges, precision model



- Werksnorm
- Zweipunkt-Vergleichsmessgerät
- selbstzentrierend
- beweglicher Messbolzen hartmetallbestückt
- auswechselbare Tastbolzen gehärtet oder hartmetallbestückt
- Wiederholbarkeit der Messwerte < 0,5µm (>280mm <1,5µm)
- Messuhraufnahme Ø 8mm
- Lieferung im Holzetui ohne Messuhr, inkl. Werkskalibrierschein (nicht Vario-Sätze)

- Works standard
- Two-point comparative measuring instrument
- Self centring
- Tungsten carbide-tipped movable probes
- Hardened or tungsten carbide-tipped interchangeable probes
- Repeatability of measured values < 0.5µm (>280mm <1.5µm)
- Dial mounting hole Ø 8mm
- Delivered in wooden box without dial gauge, incl. works calibration certificate (not vario sets)



1381 1.. :  
Tastbolzen Stahl gehärtet

1381 1.. :  
Hardened steel probes

1382 1.. :  
Tastbolzen hartmetallbestückt

1382 1.. :  
Tungsten carbide-tipped probes

! Größere Messiefen sowie Einzelgeräte auf Anfrage.

! Larger measuring depths and individual devices on request.

mm	LJ mm	Taster Stück Probe piece	kg	Nº	Nº
Standard-Sätze / Standard sets					
4,5 – 6	80	9	0,4	-	1382 101
6 – 8	100	7	0,4	-	1382 102
8 – 12	100	9	0,4	-	1382 103
12 – 20	110	9	0,6	-	1382 104
18 – 35	110	9	0,7	1381 105	1382 105
35 – 60	140	7	0,8	1381 106	1382 106
50 – 100	180	11	1,2	1381 107	1382 107
50 – 150	180	11+VL	1,2	1381 114	1382 114
100 – 160	230	7	2,3	1381 108	1382 108
160 – 290	230	7	3,8	1381 109	1382 109
280 – 510	400	7+VL	5,2	1381 110	1382 110
400 – 800	700	11	11,0	1381 111	1382 111
Kombi-Sätze / Kombi sets					
18 – 100	110 / 180	27	1,6	1381 112	1382 112
18 – 150	110 / 180	27+VL	1,7	1381 112x	1382 112x
50 – 160	180 / 230	18	2,7	1381 113	1382 113
50 – 230	180 / 230	18+VL	2,8	1381 113x	1382 113x
Vario-Sätze ( Baukastensystem ) / Vario sets (modular design)					
6 – 18	100	17	0,6	-	1382 115
18 – 160	140	19	1,2	1381 116	1382 116
160 – 430	200	7+VL	5,4	1381 117	1382 117
400 – 800	200	10+3VL	7,1	1381 118	1382 118

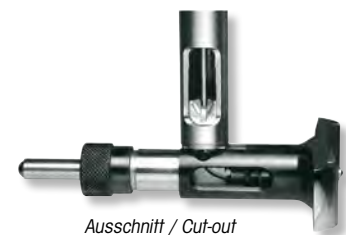

## SU Messbereich-Verlängerungen

## SU Measuring range extensions



- ▶ zur Erweiterung der Messbereiche
- ▶ Lieferung einzeln verpackt

- ▶ For extending measuring ranges
- ▶ Delivered in individual packages

l mm	l <sub>1</sub> mm	l <sub>1</sub> + mm	kg	Nº
50	50 – 100	50 – 150	0,1	1381 701
70	100 – 160 (160 – 290)	100 – 230 (160 – 360)	0,15	1381 702



## SU Messtiefen-Verlängerungen

## SU Measuring depth extensions



- ▶ zur Erweiterung der Messtiefe
- ▶ ab Messbereich 35 – 60mm

- ▶ For extending measuring depths
- ▶ From measuring range 35 – 60mm

! Andere Längen auf Anfrage.

! Other lengths on request.

l mm	Ø mm	kg	Nº	l mm	Ø mm	kg	Nº
250	12	0,15	1380 301	1000	12	0,4	1380 304
500	12	0,25	1380 302	1000	18	0,8	1380 305
750	12	0,3	1380 303	1500	18	1,0	1380 306
				2000	18	1,5	1380 307



## SU Messtiefen-Verlängerungen CARBON

## SU Measuring depth extensions CARBON



- ▶ zur Erweiterung der Messtiefe
- ▶ ab SV 160 – 800mm, Rohrdurchmesser 24mm
- ▶ Extrem geringes Gewicht (pro 1m nur 0,162Kg), hohe Formstabilität
- ▶ Maximale Messtiefe ≤ 4000mm

- ▶ For extending measuring depths
- ▶ from SV 160 – 800mm, pipe diameter 24mm
- ▶ Extremely low weight (per 1m 0.162Kg only), high strength of shape
- ▶ Maximum measuring depths ≤ 4000mm

Auf Anfrage / on request



## KT Innenfeinmessgeräte für Innenprofile und Innenverzahnungen

## KT Precision bore gauges for inside profiles and serrations



- ▶ Werksnorm
- ▶ Zweipunkt-Vergleichsmessgerät
- ▶ Messuhraufnahme Ø 8mm
- ▶ Lieferung im Holzetui ohne Kugeln und Messuhr

- ▶ Works standard
- ▶ Two-point comparative measuring instrument
- ▶ Dial mounting hole Ø 8mm
- ▶ Delivered in wooden box without balls and dial gauge

! Kugeleinsätze mit Hartmetallkugeln in Ø 1 – 15mm bitte separat bestellen.

! Tungsten carbide ball inserts Ø 1 – 15mm should be separately ordered

M l <sub>1</sub> mm	l mm	Messspanne Measuring span mm	Taster Gewinde Probe thread	kg	Nº
8 – 12	100	0,6	M1,6	0,44	1382 501
12 – 22	102	0,6	M1,6	0,59	1382 502
22 – 55	110	1,0	M2,5	0,64	1382 503
55 – 250	177	1,5	M4	1,7	1382 504



## KT Hartmetall-Kugeleinsätze, Paar

## KT Tungsten carbide ball inserts, pair



- ▶ für Innenfeinmessgeräte Serie Nr. 1382 5..
- ▶ Stufung 0,5mm
- ▶ Lieferung paarweise verpackt

- ▶ for precision bore gauges series No. 1382 5..
- ▶ Step 0,5mm
- ▶ Delivered in a package (pair)

! Andere Längen auf Anfrage.

! Other lengths on request.

Kugel / Ball Ø mm	mm	für M l <sub>1</sub> mm	Taster Gewinde Probe thread	Nº	Kugel / Ball Ø mm	mm	für M l <sub>1</sub> mm	Taster Gewinde Probe thread	Nº
1 – 4	0,5	8 – 12	M1,6	1382 601	>7 – 10	0,5	22 – 55	M2,5	1382 604
1 – 4	0,5	12 – 22	M1,6	1382 602	1 – 7	0,5	55 – 250	M4	1382 605
1 – 7	0,5	22 – 25	M2,5	1382 603	>7 – 10	0,5	55 – 250	M4	1382 606

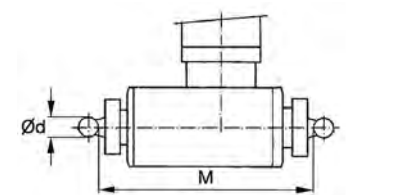

M = Messbereich ohne Kugeln  
M = Measuring range without balls



**Innenfeinmessgeräte STANDARD**

**Bore gauges, STANDARD**



**Hartmetall  
Tungsten carbide**

- ▶ Werksnorm
- ▶ Zweipunkt-Vergleichsmessgerät
- ▶ selbstzentrierend
- ▶ beweglicher Messbolzen hartmetallbestückt
- ▶ auswechselbare Tastbolzen aus Stahl gehärtet
- ▶ Messuhraufnahme Ø 8mm
- ▶ Lieferung im Etui mit Messuhr 0,01mm

- ▶ Works standard
- ▶ Two-point comparative measuring instrument
- ▶ Self centring
- ▶ Tungsten carbide-tipped moveable probes
- ▶ Hardened interchangeable probes
- ▶ Dial mounting hole Ø 8mm
- ▶ Delivered in box with dial gauge 0.01mm

∅ mm	L mm	Taster Stück Probe piece	h kg	Nº
18 – 35	150	9	0,8	1395 201
35 – 50	150	4	0,8	1395 202
50 – 160	150	12	1,0	1395 203
160 – 250	250	5	1,6	1395 204
250 – 450	250	5	2,0	1395 205
Kombi-Sätze / Kombi sets				
18 – 160	150	25	2,5	1395 221



**SL Innenfeinmessgeräte  
zum Messen bei eingefahrener Bohrstange**

**SL Precision bore gauges  
for measuring with retracted boring bar**



**Gehärtet  
Hardened**

- ▶ Werksnorm
- ▶ Zweipunkt-Vergleichsmessgerät
- ▶ selbstzentrierend
- ▶ Messflächen gehärtet
- ▶ Stange mit mm-Teilung
- ▶ Messuhraufnahme Ø 8mm
- ▶ Lieferung im Holzetui ohne Messuhr

- ▶ Works standard
- ▶ Two-point comparative measuring instrument
- ▶ Self centring
- ▶ Measuring faces hardened
- ▶ Bar with mm scale
- ▶ Dial mounting hole Ø 8mm
- ▶ Delivered in wooden box without dial gauge

D ∅ mm	d Bohrstange / Boring bar max. Ø mm	h mm	h kg	Nº
25 – 70	45	12	1,1	1386 101
35 – 105	70	17,5	1,6	1386 102
100 – 210	130	30	3,5	1386 103
100 – 280	130	30	3,5	1386 104
200 – 500	220	30	5,9	1386 105

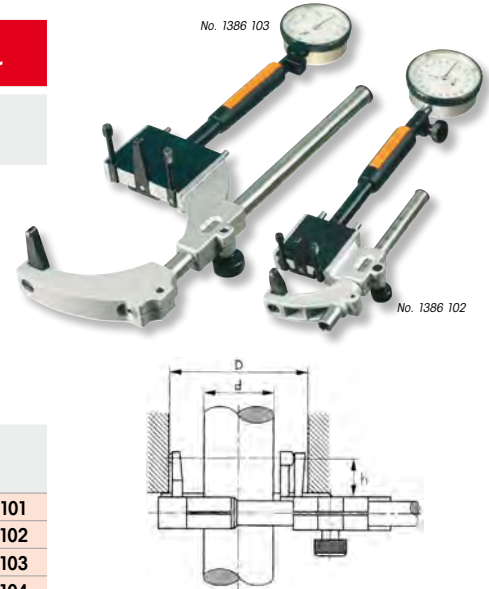

**SS Innenfeinmessgeräte  
für Sacklochbohrungen**

**SS Precision bore gauges  
for measuring blind bores**



**Hartmetall  
Tungsten carbide**

- ▶ Werksnorm
- ▶ Zweipunkt-Vergleichsmessgerät
- ▶ Messschieber und beweglicher Tastbolzen hartmetallbestückt
- ▶ Messschieber mit mm -Teilung
- ▶ Messuhraufnahme Ø 8mm
- ▶ Lieferung im Holzetui ohne Messuhr

- ▶ Works standard
- ▶ Two-point comparative measuring instrument
- ▶ Tungsten carbide-tipped calipers and moveable probes
- ▶ Calipers with mm scale
- ▶ Dial mounting hole Ø 8mm
- ▶ Delivered in wooden box without dial gauge

! Einzelgeräte auf Anfrage.

! Individual devices on request.

D ∅ mm	L mm	h kg	h mm	Nº	h mm	Nº
20 – 50	77	1,1	1,5	1387 101	1	1387 201
50 – 110	60	0,74	1,5	1387 102	1	1387 202
110 – 300	45	2,25	2	1387 103	1	1387 203
300 – 600	45	4,57	2	1387 104	1	1387 204

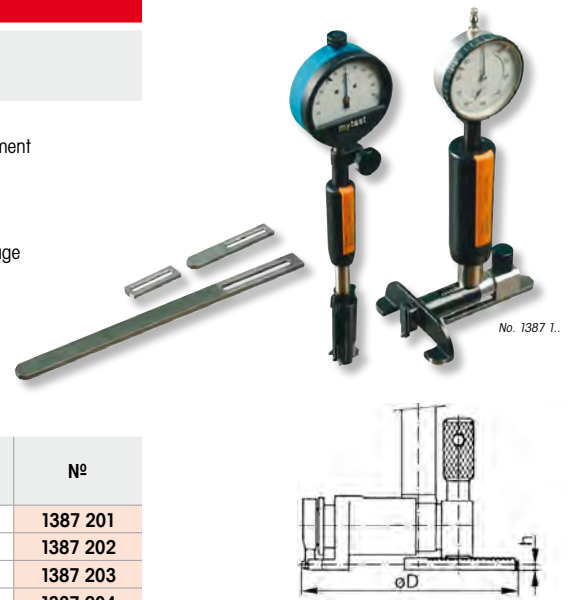

## Einstellgeräte CARBON für Innenfeinmessgeräte

## Setting instruments CARBON for bore gauges



No. 1048 70



No. 1048 711

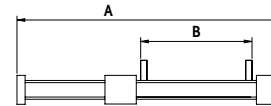

- ▶ Werksnorm
- ▶ Führungssäule aus doppeltem Kohlefaserprofil, Führungselemente aus verchromtem Stahl
- ▶ horizontal und vertikal einsetzbar
- ▶ Nennmaß wird durch Endmaße eingestellt
- ▶ Einstellbacken gehärtet
- ▶ Lieferung im Etui, ohne Endmaße

- ▶ Works standard
- ▶ Double carbon fibre bar guiding elements made of chrome steel
- ▶ Horizontal and vertical application
- ▶ Nominal sizes adjusted with gauge blocks
- ▶ Setting jaws, hardened steel
- ▶ Delivered in wooden box without gauge blocks

A mm	B mm	± kg	Nº
613	500	1,8	1048 701
813	700	2,1	1048 702
1213	1100	2,7	1048 703
Standfuß 99x79x57mm / Base 99x79x57mm		1,9	1048 711
Anschlag 113x30x15mm / Stop 113x30x15mm		0,2	1048 712

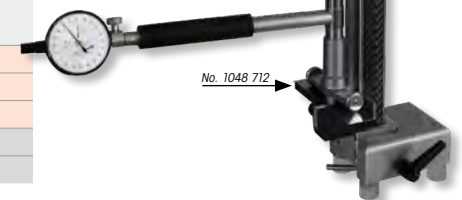

No. 1048 712

## Einstellgeräte für Innenfeinmessgeräte

## Setting instruments for bore gauges



- ▶ Werksnorm
- ▶ horizontal und vertikal einsetzbar
- ▶ Nennmaß wird durch Endmaße eingestellt
- ▶ Einstellbacken aus Hartmetall
- ▶ schwerer Standfuß
- ▶ Lieferung im Holzetui, ohne Endmaße

- ▶ Works standard
- ▶ Horizontal and vertical application
- ▶ Nominal size adjusted with gauge blocks
- ▶ Tungsten carbide setting jaws
- ▶ Heavy base
- ▶ Delivered in wooden box without gauge blocks

! Andere Einstellbacken für Fremdfabrikate auf Anfrage.

! Other setting jaws for other brands on request.

mm	± kg	Nº
4,5 – 160	5,1	1048 501
4,5 – 290	5,3	1048 502
35 – 290	5,9	1048 503
160 – 510	12,1	1048 504
160 – 800	16,0	1048 505



No. 1048 501



## Einstellgerät für Vergleichsmeßgeräte, Innengewinde- und Außengewinde

## Setting instrument for comparative meas. instruments, internal- and external threads



- ▶ **Auf Anfrage!**  
Bitte gewünschtes Gewinde, Größe und Steigung angeben.

- ▶ **On request!**  
Please indicate required thread type, size and pitch.

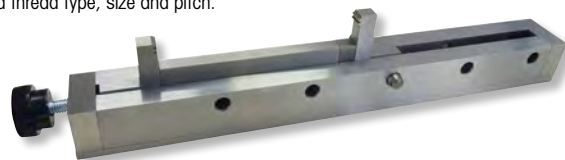

## Digital-Voreinstellgeräte SPEED SET für Vergleichsmessgeräte

## Digital pre-setting device SPEED SET for comparative measuring instruments



TOP



Hartmetall  
Tungsten carbide



No. 1396 30.

Anzeige als Tischgerät verwendbar  
Display suitable separat on table

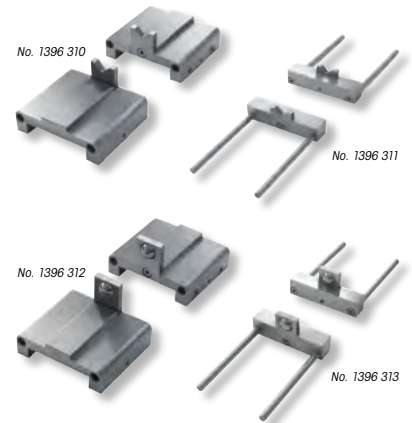

- ▶ Werksnorm
- ▶ Zum hochgenauen Einstellen von Innenfeinmessgeräten, Zweipunkt-Innen- u. Außenmessgeräten, sowie Mikrometern fast aller Hersteller in nahezu allen Ausführungen – Ersetzt eine Vielzahl von Einstellringen!
- ▶ hochgenaue Längenmessung mit Kugeltaster (Nr. 1396 312) möglich
- ▶ Messflächen aus Hartmetall
- ▶ große Messwertanzeige im Bedienerdisplay
- ▶ hochgenauer optischer Längenmaßstab
- ▶ beweglicher Schlitzen mit Präzisionslagerung, Feineinstellung und Schnellverstellung durch Handrad.
- ▶ Lieferung im Holzetui, inkl. Auflage mit Prisma, fest (Paar), Nr. 1396 310 und Auflage mit Prisma, verschiebbar (Paar), Nr. 1396 311

- ▶ Works standard
- ▶ For high precision setting of precision bore gauges, two-line internal and external measuring devices and micrometers of all manufactures in almost all versions – replaces a lot of setting rings!
- ▶ High precision length measurement with ball probes (No. 1396 312)
- ▶ Measuring faces made of tungsten carbide
- ▶ Large reading of measuring values in user display
- ▶ High precision optical length rule
- ▶ Moveable measuring device with high precision guiding, fine and quick adjustment with hand wheels.
- ▶ Delivered in wooden box, incl. supports with prism, fixed (pair), No. 1396 310 and supports with prism, moveable (pair), No. 1396 311

### Funktionen:

- ▶ Ein/Aus
- ▶ mm/inch Umschaltung
- ▶ 0-Punkt an jeder Position
- ▶ ± Preset Funktion
- ▶ Messrichtungsumkehr
- ▶ ABS / INC Funktion
- ▶ Linearkorrektur

### Functions:

- ▶ On/Off
- ▶ mm/inch commutation
- ▶ Zero setting at any position
- ▶ ± preset function
- ▶ Reversible measuring direction
- ▶ ABS / INC function
- ▶ Linear correction

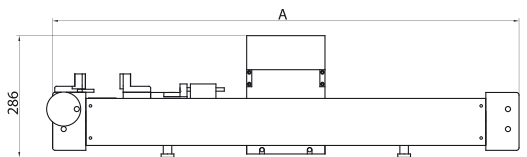

mm	inch	mm	inch	mm / 100mm	A mm	kg	Nº
400	16	0,001	.00005	0,002	796	50,0	1396 301
700	28	0,001	.00005	0,002	1096	60,0	1396 302
1000	40	0,001	.00005	0,002	1396	70,0	1396 303

Auflagen mit Prisma, fest (Paar)  
Supports with prism, fixed (pair)

1396 310

Auflagen mit Prisma, verschiebbar (Paar) für Nr. 1396 310  
Supports with prism, moveable (pair) for No. 1396 310

1396 311

Auflagen mit Kugeltaster, fest (Paar)  
Supports with ball probe, fixed (pair)

1396 312

Auflagen mit Kugeltaster, verschiebbar (Paar) für Nr. 1396 312  
Supports with ball probe, moveable (pair) for No. 1396 312

1396 313

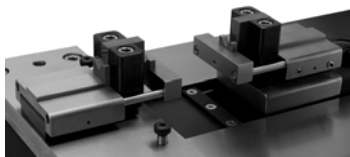

Auflage mit Prisma  
Supports with prism

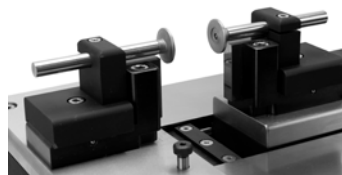

Universalhalter für Taster Dm. 8mm  
Universal holder for probes dia. 8mm

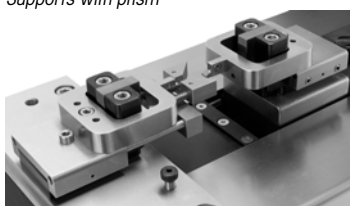

Messung von Gewinde  
Measurement of threads



Auflage mit Kugeltaster  
Supports with ball probe



Voreinstellen von Innenfeinmessgeräten  
Pre-setting of bore gauge



Voreinstellen von Innenmessschrauben  
Pre-setting of internal micrometers

**Digital-Voreinstellgeräte SPEED SET  
für Vergleichsmessgeräte  
mit Original Heidenhain-Elektronik**

**Digital pre-setting device SPEED SET  
for comparative measuring instruments  
with original Heidenhain-Electronic**



No. 1396 40.

Anzeige als Tischgerät verwendbar  
Display suitable separat on table

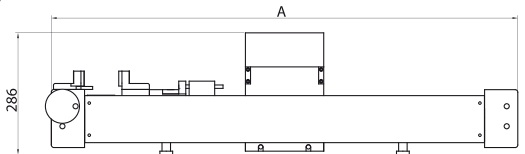
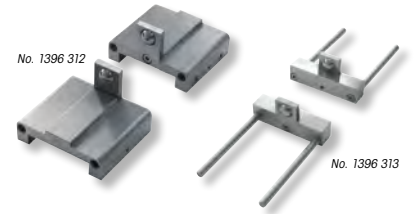
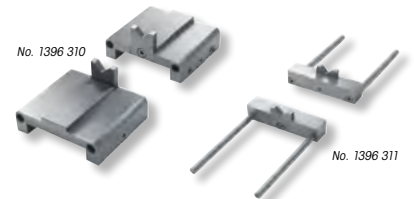

- ▶ Werksnorm
- ▶ Zum hochgenauen Einstellen von Innenfeinmessgeräten, Zweipunkt-Innen- u. Außenmessgeräten, sowie Mikrometern fast aller Hersteller in nahezu allen Ausführungen – Ersetzt eine Vielzahl von Einstellringen!
- ▶ hochgenaue Längenmessung mit Kugeltaster (Nr. 1396 312) möglich
- ▶ Messflächen aus Hartmetall
- ▶ große Messwertanzeige im Heidenhain-Bedienerdisplay
- ▶ hochgenauer optischer Längenmaßstab
- ▶ beweglicher Schlitzen mit Präzisionslagerung, Feineinstellung und Schnellverstellung durch Handrad.
- ▶ Lieferung im Holzseti, inkl. Auflage mit Prisma, fest (Paar), Nr. 1396 310 und Auflage mit Prisma, verschiebbar (Paar), Nr. 1396 311

- ▶ Works standard
- ▶ For high precision setting of precision bore gauges, two-line internal and external measuring devices and micrometers of all manufactures in almost all versions – replaces a lot of setting rings!
- ▶ High precision length measurement with ball probes (No. 1396 312)
- ▶ Measuring faces made of tungsten carbide
- ▶ Large reading of measuring values on Heidenhain-user display
- ▶ High precision optical length rule
- ▶ Moveable measuring device with high precision guiding, fine and quick adjustment with hand wheels.
- ▶ Delivered in wooden box, incl. supports with prism, fixed (pair), No. 1396 310 and supports with prism, moveable (pair), No. 1396 311

**Funktionen:**

- ▶ Ein/Aus
- ▶ mm/inch Umschaltung
- ▶ 0-Punkt an jeder Position
- ▶ ± Preset Funktion
- ▶ Messrichtungsumkehr
- ▶ ABS / INC Funktion
- ▶ Linear Korrektur

**Functions:**

- ▶ On/Off
- ▶ mm/inch commutation
- ▶ Zero setting at any position
- ▶ ± preset function
- ▶ Reversible measuring direction
- ▶ ABS / INC function
- ▶ Linear correction

mm	inch	mm	inch	100mm	A mm	kg	Nº
400	16	0,001	.00005	0,002	796	50,0	1396 401
700	28	0,001	.00005	0,002	1096	60,0	1396 402
1000	40	0,001	.00005	0,002	1396	70,0	1396 403
1500	59	0,001	.00005	0,002	1950	280,0	1396 404
2000	80	0,001	.00005	0,002	2450	366,0	1396 405



Messung von Innendurchmessern  
Measurement of inside diameters



Voreinstellen von Universalmessschiebern  
Pre-setting of universal calipers



Längenmessung von Einstellmaßen etc.  
Length measurement of setting gauge etc.



Voreinstellen von Vergleichsmessgeräten  
Pre-setting of universal calipers



Prüfen von Bügelmessschrauben  
Control of outside micrometers

**Digital-Voreinstellgeräte SPEED SET XXL  
für Vergleichsmessgeräte  
auf einer Hartsteinmessbank  
mit Original Heidenhain-Elektronik**

**Digital pre-setting device SPEED SET XXL  
for comparative measuring instruments  
on granite bench  
with original Heidenhain-Electronic**



**TOP**



**Gehärtet  
Hardened**

**Länge  
Length ≤8000mm**



- ▶ Werksnorm
- ▶ zum hochgenauen Einstellen von Innenfeinmessgeräten, Zweipunkt-Innen- u. Außenmessgeräten, sowie Mikrometern fast aller Hersteller in nahezu allen Ausführungen – Ersetzt eine Vielzahl von Einstellringen!
- ▶ Stahlmessflächen gehärtet
- ▶ große Messwertanzeige im Heidenhain-Bediendisplay ND280
- ▶ Ablesung 0,001/0,0005mm
- ▶ hochgenauer optischer Längenmaßstab
- ▶ beweglicher Schlitten mit Luftlagerung, Feineinstellung und Schnellverstellung durch Handrad.
- ▶ Lieferung im Holzkasten, inkl. Werks-Kalibrierschein

**Funktionen:**

- ▶ Ein/Aus
- ▶ mm/inch Umschaltung
- ▶ 0-Punkt an jeder Position
- ▶ ± Preset Funktion
- ▶ Messrichtungsumkehr
- ▶ ABS / INC Funktion
- ▶ Linearkorrektur

**I** Zur Angebotserstellung senden Sie uns bitte den gewünschten Messbereich.

- ▶ Works standard
- ▶ For high precision setting of bore gauges, two-line internal and external measuring devices and micrometers for all manufactures in almost all versions – replaces a lot of setting rings!
- ▶ Hardened steel measuring faces
- ▶ Large reading of measuring values on Heidenhain-user display ND280
- ▶ Reading 0,001/0,0005mm
- ▶ High precision optical length rule
- ▶ Moveable measuring device with high precision guiding, fine and quick adjustment with hand wheels.
- ▶ Delivered in storage box incl. works calibration certificate

**Functions:**

- ▶ On/Off
- ▶ mm/inch commutation
- ▶ Zero setting at any position
- ▶ ± preset function
- ▶ Reversible measuring direction
- ▶ ABS / INC function
- ▶ Linear correction

**I** Please send us the required measuring range to enable a quotation.

- 1
- 2
- 3
- 4
- 5
- 6
- 7
- 8
- 9
- 10
- 11
- 12
- 13
- 14
- 15

## Universalvergleichsmessgerät QUICK CHECK

## Universal comparative measuring bench QUICK CHECK



TOP



Gehärtet  
Hardened

- ▶ Werksnorm
- ▶ Innen- und Außenmessung
- ▶ schnelle, genaue und sichere Messung
- ▶ Messfläche aus rostfreiem, gehärtetem Stahl
- ▶ 1 einstellbarer, 1 beweglicher Taster (Messweg 20mm)
- ▶ Messkraft einstellbar 0 – 10N
- ▶ Wiederholgenauigkeit ±0,001mm
- ▶ Messuhraufnahme Ø 8mm
- ▶ Tasteraufnahme Ø 8mm
- ▶ Lieferung im Koffer ohne Messuhr

### Inhalt:

- ▶ Universalvergleichsmessgerät
- ▶ Messuhrverlängerung 20mm
- ▶ Feststellsegment
- ▶ Werkstückauflage 1 Paar
- ▶ Taster mit Kugel Ø 10mm 1 Paar
- ▶ Taster mit Teller Ø 16mm 1 Paar

### Anwendungen:

- ▶ Prüfen von Innen- und Außenmaßen, mit Sondermess-einsätzen auch in Nuten und Einstichen
- ▶ Verzahnungsmessung mit Messkugeln im Halter Nr. 2050 3.. und Adapterbolzen Nr. 1390 311

- ▶ Works standard
- ▶ Inside and outside measurements
- ▶ Fast, precise and safe measurements
- ▶ Hardened measuring surface made of stainless steel
- ▶ 1 adjustable and 1 movable probes (meas. way 20mm)
- ▶ Adjustable measuring force 0 – 10N
- ▶ Repeatability ±0.001mm
- ▶ Dial mounting hole Ø 8mm
- ▶ Probe mounting hole Ø 8mm
- ▶ Delivered in box without dial gauge

### Contents:

- ▶ Universal comparative measuring instruments
- ▶ Dial indicator extension 20mm
- ▶ Clamping segment
- ▶ Work piece supports 1 pair
- ▶ Ball probes Ø 10mm 1 pair
- ▶ Disc probes Ø 16mm 1 pair

### Applications:

- ▶ Inside and outside measurements, with special measuring inserts also in slots and recesses
- ▶ Gear tooth measurements with measuring balls in holder No. 2050 3.. and adaptor bolts No. 1390 311



Messrichtungsumkehr  
Messkraft stufenlos einstellbar  
Reversible measuring direction  
Adjustable measuring force

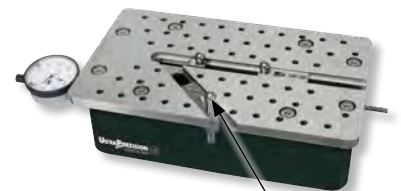

zusätzlicher Anschlag 45°  
additional anvil 45°

innen / inside mm	außen / outside mm	l mm	kg	Nº
20 – 200	0 – 180	150 x 255	6,3	1390 101
20 – 350	0 – 330	406 x 180	7,1	1390 102

Zusätzl. Anschlag / Add. Anvil

20 – 200 / 45°	0 – 180 / 45°	150 x 255	6,3	1390 103
----------------	---------------	-----------	-----	----------

## Universalvergleichsmessgerät QUICK CHECK für Dreipunktmessung

## Universal comparative measuring bench QUICK CHECK for 3-point measurement



NEW



Gehärtet  
Hardened

- ▶ Werksnorm
- ▶ Innen- und Außenmessung
- ▶ schnelle, genaue und sichere Messung
- ▶ Messfläche aus rostfreiem, gehärtetem Stahl
- ▶ 2 einstellbare, 1 beweglicher Taster (Messweg 20mm)
- ▶ Messkraft einstellbar 0 – 10N
- ▶ Wiederholgenauigkeit ± 0,001mm
- ▶ Messuhraufnahme Ø8mm
- ▶ Tasteraufnahme Ø8mm
- ▶ Lieferung im Koffer ohne Messuhr

### Inhalt:

- ▶ Universalvergleichsmessgerät
- ▶ Messuhrverlängerung 20mm
- ▶ Feststellsegment
- ▶ Taster mit Kugel Ø 10mm, 3 Stück

### Anwendungen:

- ▶ Schnelle und sichere Serienmessung von Innen- und Außenmaßen, mit Sondermesseinsätzen auch in Nuten und Einstichen

- ▶ Works standard
- ▶ Inside and outside measurements
- ▶ Fast, precise and safe measurements
- ▶ Hardened measuring surface made of stainless steel
- ▶ 2 adjustable and 1 movable probes (meas. way 20mm)
- ▶ Adjustable measuring force 0 – 10N
- ▶ Repeatability ± 0.001mm
- ▶ Dial mounting hole Ø8mm
- ▶ Probe mounting hole Ø8mm
- ▶ Delivered in box without dial gauge

### Contents:

- ▶ Universal comparative measuring instrument
- ▶ Dial indicator extension 20mm
- ▶ Clamping segment
- ▶ Ball probes Ø 10mm, 3 pieces

### Applications:

- ▶ Fast and safe series measurement of inside and outside dimensions, with special measuring inserts also in slots and recesses

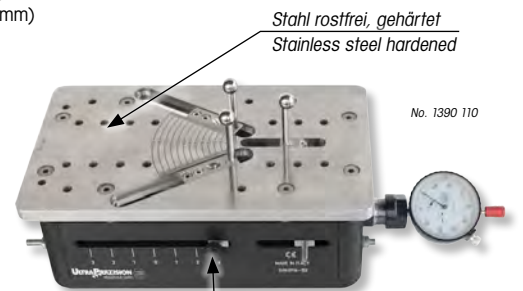

Messrichtungsumkehr  
Messkraft stufenlos einstellbar  
Reversible measuring direction  
Adjustable measuring force

Der angegebene Messbereich bezieht sich auf Kugeltaster Ø 10mm.

The mentioned measuring range refers to ball probes Ø 10mm.

innen/inside mm	außen/outside mm	l mm	kg	Nº
48 – 128	28 – 103	150x255	7,6	1390 110

**Prismatischer Anschlag für QUICK CHECK V stop for QUICK CHECK**



- ▶ Werksnorm
- ▶ Spezialstahl gehärtet
- ▶ Zur schnellen, sicheren Durchmesserprüfung ohne Umkehrpunktsuche
- ▶ Wiederholungsgenauigkeit der Mechanik  $\pm 0,001\text{mm}$
- ▶ Lieferung einzeln verpackt ohne Quick Check und Messuhr

**Handhabung:**

- ▶ Das Prisma ist in der Nute verschiebbar und kann auf verschiedene Durchmesser eingestellt werden.
- ▶ Die Voreinstellung erfolgt mittels Einstellmeister oder Prüfscheibe.
- ▶ Der erforderliche Korrekturfaktor wird in der Messuhr eingegeben und bleibt gespeichert.
- ▶ Die Korrektur des Messwertes erfolgt automatisch.
- ▶ Der Anwender liest das exakte Messergebnis direkt auf dem Messuhrdisplay ab.
- ▶ Weitere Berechnungen sind nicht erforderlich.

- ▶ Works standard
- ▶ Special steel hardened
- ▶ For a reliable diameter measuring, no search of the reversal point.
- ▶ Repeatability of the mechanic  $\pm 0.001\text{mm}$
- ▶ Delivered in individual packages without QUICK CHECK and dial gauge

**Operation:**

- ▶ The V anvil can be slid in the slot and adjusted for different diameters.
- ▶ The pre-setting through setting master or an optical flat.
- ▶ The required correction factor is entered into the dial gauge display and shall remain saved.
- ▶ The correction of the measured value follows automatically.
- ▶ The user reads the exact measuring result on the dial gauge display directly.
- ▶ Further calculations are not necessary.

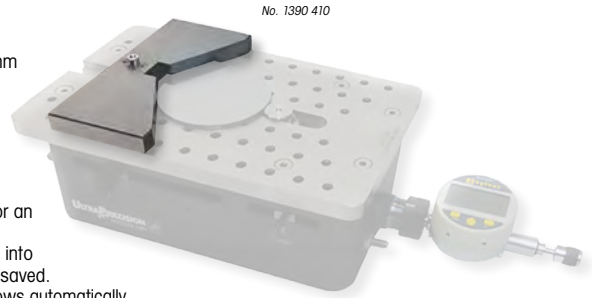

No. 1390 410

! Es wird eine Messuhr mit Umrechnungsfaktor-Funktion benötigt. Wir empfehlen unsere Messuhr Nr. 1301 106 (siehe Seite 4.3)

! A dial gauge with conversion factor – function is needed. We recommend our dial gauge no. 1301 106 (see page 4.3)

! Der angegebene Werkstück  $\varnothing$  bezieht sich auf das Basisgerät QUICK CHECK Nr. 1390 101

! The mentioned workpiece  $\varnothing$  refers to standard QUICK CHECK no. 1390 101

L mm	max. Werkstück max. Workpiece $\varnothing$ mm	$\bar{m}$ kg	Nº
150x10	135mm	0,5	1390 410

> Werkstück  $\varnothing$  auf Anfrage / > Workpiece  $\varnothing$  on request

**Halter für QUICK CHECK zum Kippen der Messfläche**

**Holder for QUICK CHECK to tilt measuring surface**



- ▶ Optimale Positionierung des Werkstücks durch schräggestellte Messfläche
- ▶ Lieferung einzeln verpackt

- ▶ Optimal positioning of the workpiece with bevelled meas. surface
- ▶ Delivered in individual packages



No. 1390 401

$\angle$	$\bar{m}$ kg	Nº
Schrägstellung Messfläche 10° bis 40° Bevelled meas. surface 10° to 40°	0,5	1390 401

**Messeinsätze für QUICK CHECK, Paar**

**Probes for QUICK CHECK, pair**

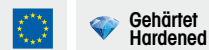

- ▶ Spezialstahl gehärtet
- ▶ Lieferung als Paar einzeln verpackt

- ▶ Special steel hardened
- ▶ Delivered as pair in individual packages

Zubehör für Spezialanwendungen auf Anfrage.  
Special application accessories on request.

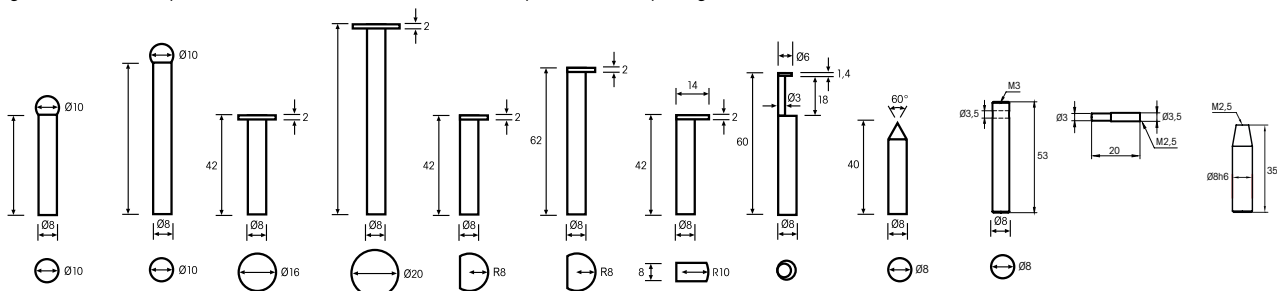

Nº	1390 301	1390 302	1390 303	1390 304	1390 305	1390 306	1390 307	1390 308	1390 309	1390 310	1390 311	1390 300
----	----------	----------	----------	----------	----------	----------	----------	----------	----------	----------	----------	----------

## Universalvergleichsmessgerät QUICK CHECK mit höhenverstellbarem Tisch (0-28mm)

## Universal comparative measuring bench QUICK CHECK with height adjustable table (0-28mm)



- ▶ Werksnorm
- ▶ Innen- und Außenmessung
- ▶ X- und Z-Achse
- ▶ Rechtwinkligkeit 0,01mm
- ▶ Zur Ø-Prüfung auf unterschiedlichen Messebenen
- ▶ schnelle, genaue und sichere Messung
- ▶ Messfläche aus rostfreiem, gehärtetem Stahl 50 HRC
- ▶ 1 einstellbarer, 1 beweglicher Taster (Messweg 20mm)
- ▶ Messkraft einstellbar 0 -10N
- ▶ Wiederholgenauigkeit ±0,001mm
- ▶ Messuhraufnahme Ø 8mm
- ▶ Tasteraufnahme Ø 8mm
- ▶ Lieferung im Koffer ohne Messuhr

### Inhalt:

- ▶ Universalvergleichsmessgerät
- ▶ Messuhrverlängerung 20mm
- ▶ Feststellsegment
- ▶ Werkstückauflage 1 Paar
- ▶ Taster mit Kugel Ø 10mm 1 Paar
- ▶ Taster mit Teller Ø 16mm 1 Paar

### Anwendungen:

- ▶ Prüfen von Innen- und Außenmaßen, mit Sondermess-einsätzen auch in Nuten und Einstichen
- ▶ Verzahnungsmessung mit Messkugeln im Halter Nr. 2050 3.. und Adapterbolzen Nr. 1390 311

- ▶ Works standard
- ▶ Inside and outside measurements
- ▶ X- and Z-axis
- ▶ Rectangularity 0.01mm
- ▶ For Ø-check on different measuring levels
- ▶ Fast, precise and safe measurements
- ▶ Hardened measuring surface made of stainless steel 50 HRC
- ▶ 1 adjustable and 1 movable probes (meas. way 20mm)
- ▶ Adjustable measuring force 0 -10N
- ▶ Repeatability ±0.001mm
- ▶ Dial mounting hole Ø 8mm
- ▶ Probe mounting hole Ø 8mm
- ▶ Delivered in box without dial gauge

### Contents:

- ▶ Universal comparative measuring instruments
- ▶ Dial indicator extension 20mm
- ▶ Clamping segment
- ▶ Work piece supports 1 pair
- ▶ Ball probes Ø 10mm 1 pair
- ▶ Disc probes Ø 16mm 1 pair

### Applications:

- ▶ Inside and outside measurements, with special measuring inserts also in slots and recesses
- ▶ Gear tooth measurements with measuring balls in holder No. 2050 3.. and adaptor bolts No. 1390 311

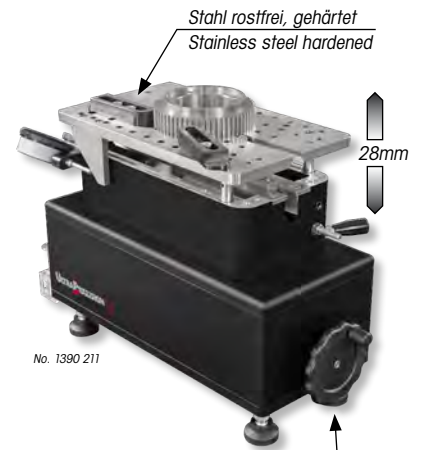
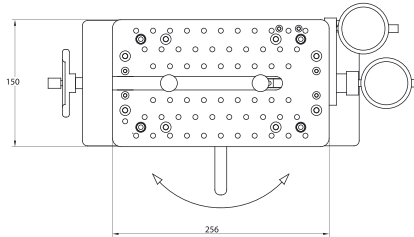
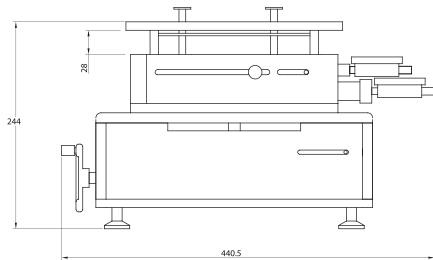

Tischhöhe Feineinstellung mit Handrad  
Table height fine adjustment with hand wheel



innen / inside mm	außen / outside mm	l mm	kg	Nº
20 - 200	0 - 180	150 x 255	12,7	1390 211

## Messtaster Adapter-Set für QUICK CHECK

## Probe adapter set for QUICK CHECK



- ▶ Messtaster Paar Ø 8x53mm mit Aufnahmebohrung Ø 3,5mm
- ▶ Messeinsatzadapter Paar Ø 3/3,5mm mit Innengewinde M2,5 (für Messeinsätze ULTRA No. 1330 ... Kat.Seite 4.16 und ULTRA No. 2050 3..)
- ▶ Messtaster Paar Ø 8x45mm oben mit Innengewinde M2,5 (für Messeinsätze ULTRA No. 1330 ... Kat.Seite 4.16)
- ▶ Fluchtdorn Ø 3,5x50mm
- ▶ Lieferung im Holzetui

- ▶ Probe pair Ø 8x53mm with mounting hole 3.5mm
- ▶ Adapter pair with Ø 3/3.5mm and inside thread M2.5 (for inserts ULTRA No. 1330 ... cat. page 4.16 and ULTRA No. 2050 3..)
- ▶ Probe pair Ø 8x45mm with inside thread M2.5 at top (for inserts ULTRA No. 1330 ... cat. page 4.16)
- ▶ Aligning mandrel Ø 3.5x50mm
- ▶ Delivered in wooden case



### Anwendung / Application:

Messeinsätze  
Measuring inserts  
No. 1330 210-D

Messeinsätze  
Measuring inserts  
No. 2050 303

Messeinsätze  
Measuring inserts  
No. 1330 103

### Anwendungen:

- ▶ Mit diesem Zubehörsatz können alle Messeinsätze für Messuhren mit Gewinde M2,5 sowie Messkugeln im Halter adaptiert werden.
- Ihr QUICK CHECK Universalmessgerät wird einfach und kostengünstig, auf ständig neue Messaufgaben angepasst.

### Applications:

- ▶ With this accessories you can adapt all measuring inserts for dial gauges with thread M2.5 as well as measuring balls in holder.
- You can modify your QUICK CHECK universal measuring bench for your daily new measuring applications, easily and cost saving.

Satz Set	l mm	kg	Nº
7 Stck. / 7 pieces	150 x 50 x 20	0,3	1390 901



**ON Innenmessgeräte für Nuten und Einstiche**

**ON Internal measuring gauges for slots and grooves**



- ▶ Werksnorm
- ▶ Zweipunkt-Vergleichsmessgerät
- ▶ Hub 10mm
- ▶ Pistolengriff
- ▶ Messuhraufnahme Ø 8mm
- ▶ Lieferung im Holzetui ohne Messuhr und ohne Spreitzaster

- ▶ Works standard
- ▶ Two-point comparative measuring instrument
- ▶ Hub 10mm
- ▶ Pistol handle
- ▶ Dial mounting hole Ø 8mm
- ▶ Delivered in wooden box without dial gauge and without probes



No. 1388 100

! Sondergeräte sowie Messbereiche bis 200mm auf Anfrage.

! Special devices and measuring ranges up to 200 mm on request.

kg	Nº
1,18	1388 100

**ON Spreitzaster für Nuten und Einstiche für Innenmessgerät ULTRA Nr. 1388 100**

**ON Probe for slots and grooves for internal measuring gauges ULTRA No. 1388 100**



**Gehärtet Hardened**

- ▶ Werksnorm
- ▶ Messflächen gehärtet
- ▶ Lieferung einzeln verpackt

- ▶ Works standard
- ▶ Measuring faces hardened
- ▶ Delivered in individual packages



! Andere Messbereiche bis 200mm auf Anfrage.

! Other measuring ranges up to 200mm on request.

d2 mm	d1 mm	MT mm	b min. mm	kg	Nº
6 – 8	6	60	0,8	0,4	1388 101
8 – 12	8	60	1,2	0,4	1388 102
10 – 14	10	60	1,2	0,6	1388 103
12 – 18	12	60	1,2	0,6	1388 104
16 – 22	16	60	1,2	0,7	1388 105
> 22 – 200mm auf Anfrage / on request					

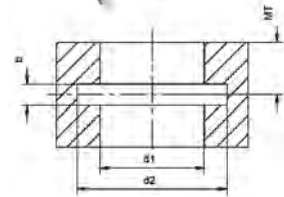

**Innenfasenmessgeräte**

**Chamfer measuring gauges, internal**



**Gehärtet Hardened**

- ▶ Werksnorm
- ▶ Messen des GrößtØ von Innenkegeln
- ▶ Messflächen aus gehärtetem Spezialstahl
- ▶ Kegel 90°
- ▶ Lieferung in Kunststoffbox inkl. Messuhr

- ▶ Works standard
- ▶ Measurement of the largest Ø of inside chamfers
- ▶ Hardened special steel measuring faces
- ▶ 90° taper
- ▶ Delivered in plastic box incl. dial gauge



No. 1389 101

No. 1389 102

mm	< mm	kg	Nº
0,5 – 20	0,01	0,4	1389 101
20 – 40	0,01	0,7	1389 102

**Fasenlängenmessgeräte**

**Chamfer length measuring device**



**NEW**

**Gehärtet Hardened**

- ▶ Werksnorm
- ▶ Messen der Fasenlängen von Bohrungen und Außendurchmessern
- ▶ Messflächen aus gehärtetem Spezialstahl
- ▶ Für Fasenwinkel ≥ 30° und Bohrungsdurchmesser ≥ 6mm
- ▶ Lieferung in Kunststoffbox inkl. Einstellstück und Messuhr

- ▶ Works standard
- ▶ To measure chamfer-length of bore holes and outer diameter
- ▶ Hardened special steel measuring faces
- ▶ For chamfer angle ≥ 30° and bore diameter ≥ 6mm
- ▶ Delivered in plastic box incl. setting gauge and dial gauge



No. 1389 501

**Handhabung:**  
▶ Von der Planseite der zu messenden Fase ausgehend bezieht sich der zweistufige Messkontakt auf die der Fase folgende Bohrung. Der größere Durchmesser des Messkontakts (+ 0,2mm) liegt in der Fase an – bei einer 45° Fase entspricht das einem Preset von 0,1mm Fasenlänge.

**Operation:**  
▶ Beginning from the flat surface of the chamfer to be measured, the two-step measuring contact refer to the bore below the chamfer. The larger diameter of the measuring contact (+0.2mm) touches the chamfer – for 45° chamfer this corresponds to a preset of 0.1mm chamfer length.

mm	< mm	kg	Nº
0,2 – 5	0,01	0,75	1389 501

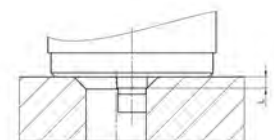

**Universalvergleichsmessgeräte  
für Innen- und Außenmessung TGU**

**Universal comparative measuring instrument  
for inside and outside measurement TGU**



Länge  
Length **≤3000mm**

- ▶ Werksnorm
- ▶ Messrichtungsumkehr
- ▶ Messweg max. 18mm
- ▶ konstante Messkraft
- ▶ Messeinsätze auswechselbar
- ▶ Messuhraufnahme Ø8mm
- ▶ ohne Zubehör
- ▶ Lieferung im Etui, ohne Messuhr und Messarme

- ▶ Works standard
- ▶ Reversible measuring direction
- ▶ Measuring way max. 18mm
- ▶ Constant measuring force
- ▶ Interchangeable measuring inserts
- ▶ Dial mounting hole Ø8mm
- ▶ Without accessories
- ▶ Delivered in a case without dial gauge and measuring arms



No. 1397 601

**Anwendungen:**

- ▶ Prüfen von Innen- und Außenmaßen, mit Sondermess-einsätzen auch in Nuten und Einstichen
- ▶ Mit Adapter Nr. 1398 262 können alle Standard-Taster mit Gewinde M2,5 montiert werden.
- ▶ Gewindemessung mit Gewindeflankeneinsätzen Schaft Ø3,5mm, Nr. 2048 5.. / 2048 6..
- ▶ Verzahnungsmessung mit Messkugeln im Halter Nr. 2050 3.. und Adapterbolzen Nr. 1390 311
- ▶ Messbereich mit Verlängerungen bis 3000mm erweiterbar

**Applications:**

- ▶ Inside and outside measurements, with special measuring inserts also in slots and recesses
- ▶ All standard measuring inserts with connection thread M2.5 can be mounted with adapter No. 1398 262
- ▶ Thread measurements with thread inserts shaft Ø3,5mm, Nr. 2048 5.. / 2048 6..
- ▶ Gear tooth measurements with measuring balls in holder No. 2050 3.. and adapter bolts No. 1390 311
- ▶ Measuring range with extensions to 3000mm expandable



innen / inside mm	außen / outside mm	kg	Nº
30 – 250	0 – 215	2,6	<b>1397 601</b>
Digital-Messuhr 0,001mm mit Schutzklappe Digital dial indicators 0,001mm with protective shroud			<b>1398 270</b>
Digital-Messuhr 0,001mm (mit Bluetooth) mit Schutzklappe Digital dial indicators 0,001mm (with Bluetooth) with protective shroud			<b>1398 270b</b>

**Messbereich-Verlängerungen**

**Measuring range extensions**



▶ Lieferung einzeln verpackt

▶ Delivered in individual packages



No. 1398 251

No. 1398 252

innen / inside mm	außen / outside mm	kg	kg	Nº
30 – 400	0 – 365	150	0,8	<b>1398 251</b>
30 – 750	0 – 715	500	1,8	<b>1398 252</b>

## Zubehör für Universalvergleichsmessgeräte TGU

## Accessoires for universal comparative measuring instruments TGU



► Lieferung paarweise verpackt

► Delivered in packages (pair)



**BOWERS GROUP**

! Andere Messeinsätze für Spezialanwendungen auf Anfrage.  
Gewindeflankeneinsätze auf Anfrage.

! Other measuring inserts for special applications on request.  
Thread inserts on request.

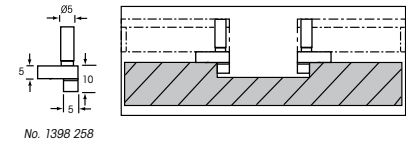
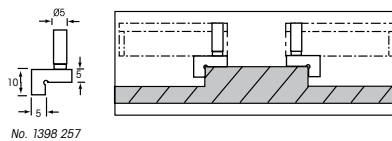
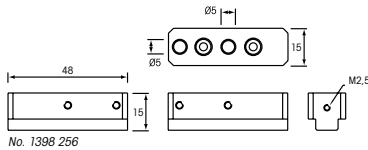

Typ Type	ℓ mm	█ kg	Nº
Messarme für Messeinsätze Ø5mm / Measuring arms for inserts Ø5mm	48 x 15 x 15	0,05	1398 256
Schultermesseinsätze plan (außen) / Shoulder inserts plain (outside)	-	0,05	1398 257
Schultermesseinsätze halbzyklindrisch (innen) / Shoulder inserts half-cylindrical (inside)	-	0,05	1398 258

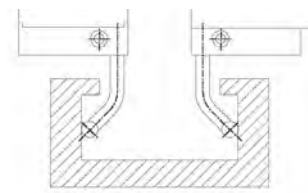
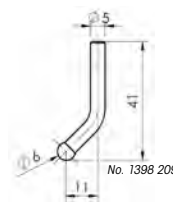
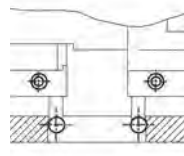
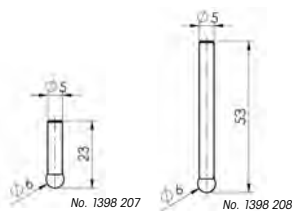

Typ Type	ℓ mm	█ kg	Nº
Taster mit Kugel / Ball probe	Ø6 / Ø5 x 23	0,1	1398 207
Taster mit Kugel / Ball probe	Ø6 / Ø5 x 53	0,1	1398 208
Messtaster gekröpft / Ball probes cranked	Ø6 / 41 x 11	0,1	1398 209

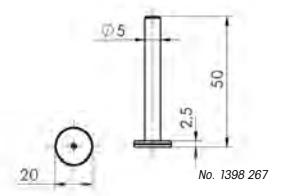
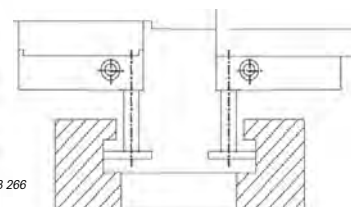
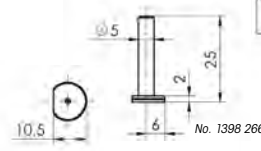
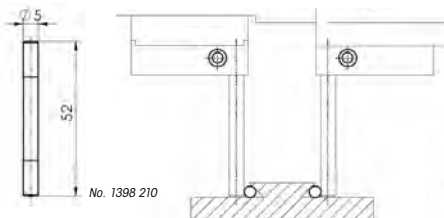

Typ Type	ℓ mm	█ kg	Nº
Messtaster zylindrisch / Measuring probe cylindrical	Ø5 x 52	0,1	1398 210
Messtaster mit Teller / Disc probe	Ø12 x 2 / Ø5 x 25	0,1	1398 266
Messtaster mit Teller / Disc probe	Ø20 x 2,5 / Ø5 x 50	0,1	1398 267

**Zubehör  
für Universalvergleichsmessgeräte TGU**

**Accessoires for universal comparative  
measuring instruments TGU**



**BOWERS GROUP**

► Lieferung paarweise verpackt

► Delivered in packages (pair)

! Andere Messeinsätze für Spezialanwendungen auf Anfrage.  
Gewindefankeneinsätze auf Anfrage.

! Other measuring inserts for special applications on request.  
Thread inserts on request.

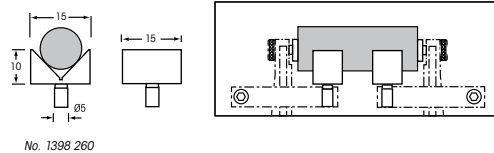
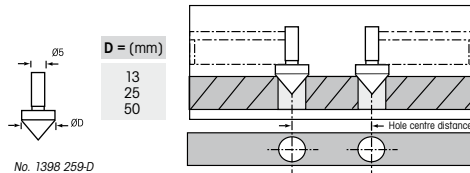

Typ Type	ℓ mm	⊖ kg	Nº
Messtaster kegelig / Conical probe	Ø5	0,5	1398 259-D
Werkstückauflage, prismatisch / Workpiece support, prismatic	Ø5	0,8	1398 260

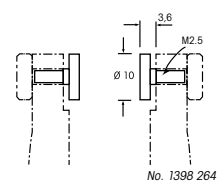
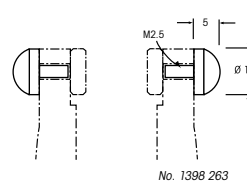
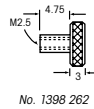
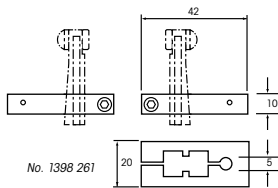

Typ Type	ℓ mm	⊖ kg	Nº
Tiefenanschlag / Depth stop	42x20x10	0,9	1398 261
Adapter für Messeinsätze M2,5 / Adapter for measuring inserts M2.5	Ø5	1,6	1398 262
Ballige Messeinsätze / Spherical measuring inserts	Ø10/5/M2,5	0,03	1398 263
Flache Messeinsätze / Flat measuring inserts	Ø10/3,6/M2,5	0,02	1398 264

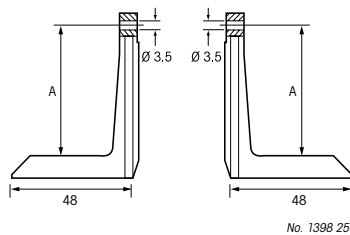

Typ Type	A mm	⊖ kg	Nº
Messarme / Measuring arms	50	0,1	1398 253
Messarme / Measuring arms	75	0,8	1398 254
Messarme / Measuring arms	100	0,9	1398 255

## Digital-Universalvergleichsmessgeräte für Innen- und Außenmessungen

## Digital Universal comparative measuring instrument Inside and outside measurements



- ▶ Werksnorm
- ▶ Schutzart IP65, Sylvac System
- ▶ großes LCD-Display
- ▶ Feststellschraube und Feineinstellung
- ▶ Schiene aus rostfreiem Stahl gehärtet, Anbauteile aus Spezial-Aluminium
- ▶ Messrichtungsumkehr
- ▶ Messkraft stufenlos einstellbar
- ▶ Messeinsätze auswechselbar
- ▶ Messuhrablesung 0,01mm
- ▶ Toleranzmarken einstellbar
- ▶ Tiefenanschlag im 5mm Raster verstellbar
- ▶ Lieferung im Holzetui inkl. Standardmessarme (Paar)

### Funktion:

- ▶ Ein/Aus, mm/inch Umschaltung, 0-Punkt an jeder Position, ± Preset Funktion, Hold Funktion, Datenausgang Opto

- ▶ Works standard
- ▶ Protection class IP 65, Sylvac System
- ▶ Large LCD display
- ▶ Locking screw and fine adjustment
- ▶ Bar stainless steel hardened, adapted parts made of special aluminium alloy
- ▶ Reversible measuring direction
- ▶ Adjustable measuring force
- ▶ Interchangeable measuring inserts
- ▶ Dial gauge reading 0.01mm
- ▶ Adjustable tolerance marks
- ▶ Measuring depth stop in 5mm steps adjustable
- ▶ Delivered in a wooden case incl. dial gauge and measuring arms (pair)

### Functions:

- ▶ On/Off, mm/inch commutation, Zero setting at any position, ± Preset function, Hold function, Data output Opto

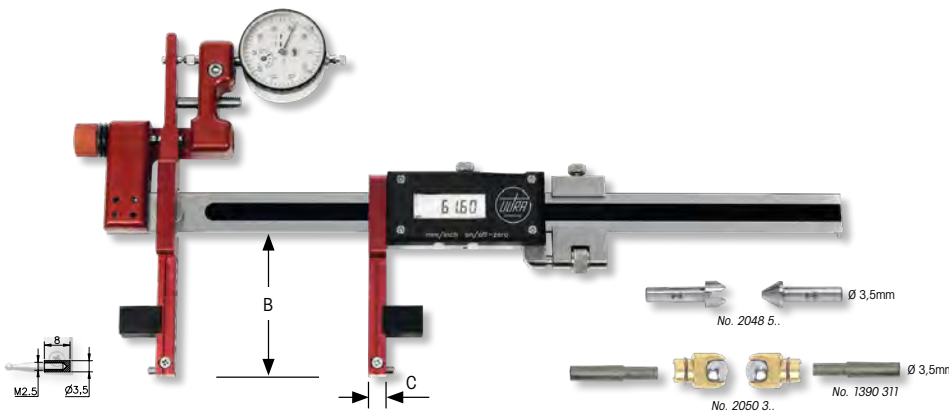

### Anwendungen:

- ▶ Prüfen von Innen- und Außenmaßen, mit Sondermess-einsätzen auch in Nuten und Einstichen
- ▶ Alle Standard-Taster mit Gewinde M2,5 oder Schaft Ø3,5mm können montiert werden
- ▶ Gewindemessung mit Gewindeflankeneinsätzen Schaft Ø3,5mm Nr. 2048 5.. / 2048 6..
- ▶ Verzahnungsmessung mit Messkugeln im Halter Nr. 2050 3.. und Adapterbolzen Nr. 1390 311

### Handhabung:

- ▶ Die Messrichtung (Innenmessung oder Außenmessung) wird umgekehrt in dem die Messuhr und der federbelastete Anschlag auf der anderen, gegenüberliegenden Seite montiert werden.
- ▶ Das Messgerät wird z.B. mit einem Einstellring Ø 50mm voreingestellt in dem die Digitalanzeige mit Preset auf 50mm eingestellt wird und die Messuhr auf den Wert 0 (Umkehrpunkt !) Durch Verfahren des beweglichen Schnabels kann nun jeder beliebige Messwert innerhalb des gesamten Messbereiches über die Digitalanzeige eingestellt werden. Die Abweichung des Werkstücks zum eingestellten Wert (Digitalanzeige) wird an der Messuhr in 1/100mm abgelesen (Umkehrpunkt !).

**Vorteil:** Ein Einstellmeister reicht aus, um das Gerät, innerhalb des Messbereiches, auf ein beliebiges Werkstückmaß vor einzustellen.

### Application:

- ▶ Inside and outside measurements, with special measuring inserts also in slots and recesses
- ▶ All standard measuring inserts with connection thread M2.5 or shaft Ø3.5mm can be mounted
- ▶ Thread measurements with thread inserts shaft Ø 3.5mm No. 2048 5.. / 2048 6..
- ▶ Gear tooth measurements with measuring balls in holder No. 2050 3.. and adaptor bolts No. 1390 311

### Operation:

- ▶ The measuring direction (inside our outside measurements) will be changed by mounting the dial gauge and the spring loaded stop at the opposite side.
- ▶ The setting of the instrument will be made by using for example a Ø 50mm setting ring gauge, the digital display will be preset to the value 50mm and the dial gauge will be adjusted to 0 (reversing point !). By sliding the movable jaw (electronic device) you can preset now each value up to the complete measuring range of the instrument – the deviation of your work piece, in comparison to your preset value at your digital display, will be read at the dial gauge in 1/100mm (reversing point !).

**Advantage:** One setting master is sufficient to adjust the instrument and to be able to use it after that for any size within the instrument capacity.

innen / inside mm / inch		außen / outside mm / inch		B mm	C mm	mm	inch	mm	kg	Nº
20 – 200	1 – 8	0 – 138	0 – 5,5	55	8x8	0,01	.0005	0,02	0,6	1399 501
24 – 300	1 – 12	0 – 230	0 – 9	75	10x10	0,01	.0005	0,02	0,95	1399 502
24 – 500	1 – 20	0 – 430	0 – 17	75	10x10	0,01	.0005	0,02	1,15	1399 503
Messstiefenanschlag für beweglichen Messarm Measuring depth stop for movable arm										1399 302
Messstiefenanschlag für festen Messarm Measuring depth stop for fixed arm										1399 303
Adapterbolzen (Paar) Adaptor bolts (pair)										1390 311

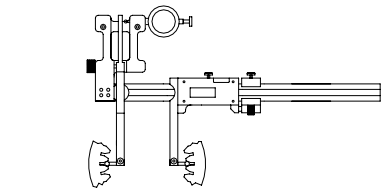

Verzahnung innen / außen  
Gear tooth inside / outside

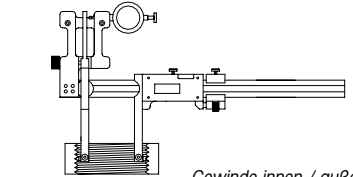
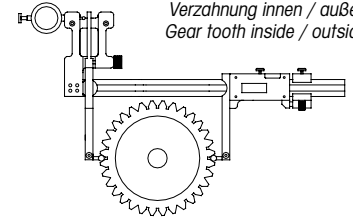

Gewinde innen / außen  
Thread inside / outside

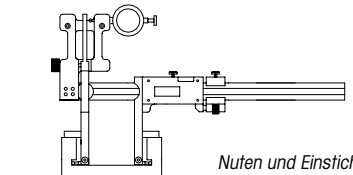
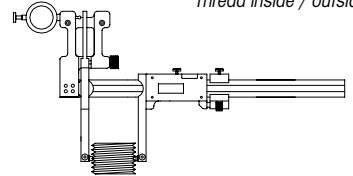

Nuten und Einstiche  
innen / außen  
slots and recesses  
inside / outside

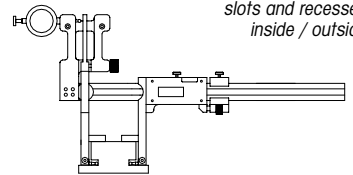

No. 1399 302

Messstiefenanschlag  
für beweglichen Messarm  
Measuring depth stop  
for movable arm

No. 1399 303

Messstiefenanschlag  
für festen Messarm  
Measuring depth stop  
for fixed arm

## Universalvergleichsmessgeräte CARBON für Innen- und Außenmessung

## Universal comparative measuring instrument CARBON for inside and outside measurements



TOP



CARBON

- ▶ Werksnorm
- ▶ Stange aus Kohlefaser, Führungselemente aus Stahl verchromt
- ▶ extrem geringes Gewicht, hohe Formstabilität
- ▶ Messrichtungsumkehr
- ▶ Messweg max. 20mm
- ▶ Messeinsätze auswechselbar
- ▶ Messuhrablesung 0,01mm
- ▶ Toleranzmarken einstellbar
- ▶ Messuhraufnahme Ø8mm
- ▶ Lieferung im Etui inkl. Messuhr, Adapter (Paar) und Messtasterpaar Ø 20mm

- ▶ Works standard
- ▶ Carbon fibre bar, guiding elements made of chromed steel
- ▶ Extremely low weight, high strength of shape
- ▶ Reversible measuring direction
- ▶ Measuring way max. 20mm
- ▶ Interchangeable measuring inserts
- ▶ Dial gauge reading 0.01mm
- ▶ Adjustable tolerance marks
- ▶ Dial mounting hole Ø 8mm
- ▶ Delivered in a case incl. dial gauge, adapters (pair) and probe pair Ø 20mm



Messeinsatz frei beweglich durch neue Messtiefenanschläge für größtmögliche Messgenauigkeit.

Measuring inserts free movable due to new designed measuring depth stop assure high precision measurements.

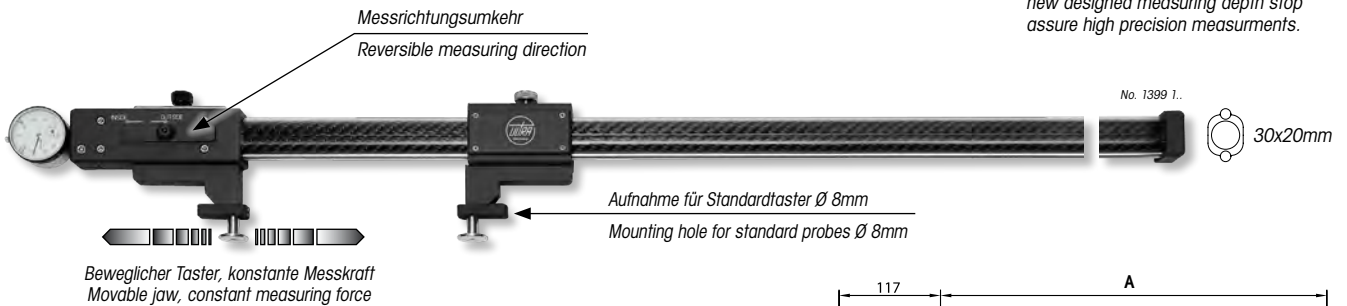

### Anwendungen:

- ▶ Prüfen von Innen- und Außenmaßen, mit Sondermess-einsätzen auch in Nuten und Einstichen
- ▶ Mit Messarme Nr. 1851 810 können alle Standard-Taster mit Gewinde M2,5 oder Schaft Ø3,5mm montiert werden
- ▶ Gewindemessung mit Gewindeflankeneinsätzen Schaft Ø3,5mm Nr. 2048 5.. / 2048 6..
- ▶ Verzahnungsmessung mit Messkugeln im Halter Nr. 2050 3.. und Adapterbolzen Nr. 1390 311

### Application:

- ▶ Inside and outside measurements, with special measuring inserts also in slots and recesses
- ▶ All standard measuring inserts with connection thread M2.5 or shaft Ø3.5mm can be mounted with measuring arms no. 1851 810
- ▶ Thread measurements with thread inserts shaft Ø 3.5mm No. 2048 5.. / 2048 6..
- ▶ Gear tooth measurements with measuring balls in holder No. 2050 3.. and adaptor bolts No. 1390 311

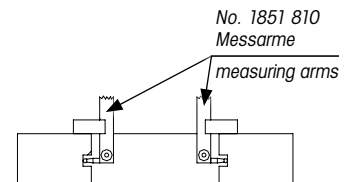
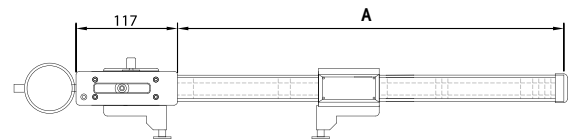

mm	A mm	mm	kg	Nº
400	550	30 x 20	1,3	1399 101
600	750	30 x 20	1,9	1399 102
800	950	30 x 20	2,4	1399 103

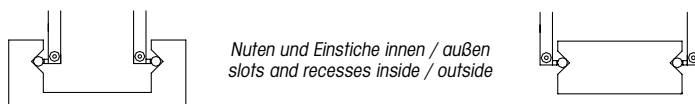
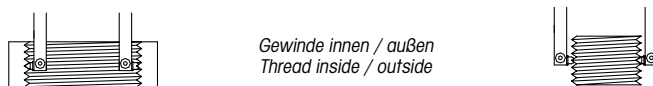
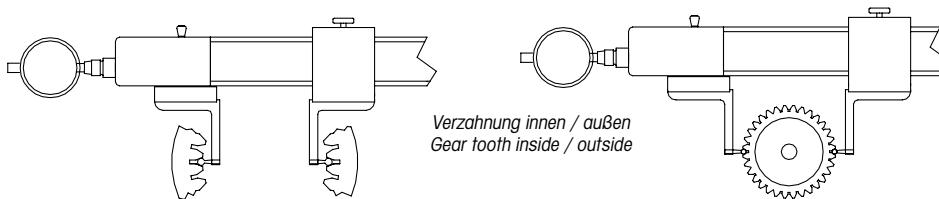
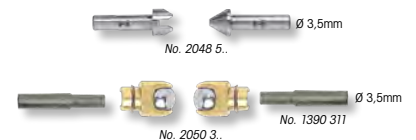

Messeinsätze siehe Seite 6.36 / Probes see page 6.36

**Universalvergleichsmessgeräte CARBON für Innen- und Außenmessung**

**Universal comparative measuring instrument CARBON for inside and outside measurements**



- ▶ Werksnorm
- ▶ Stange aus Kohlefaser, Führungselemente aus Stahl verchromt
- ▶ extrem geringes Gewicht, hohe Formstabilität
- ▶ Messrichtungsumkehr
- ▶ Messweg max. 20mm
- ▶ Messeinsätze auswechselbar
- ▶ Messuhrablesung 0,01mm
- ▶ Toleranzmarken einstellbar
- ▶ Messuhraufnahme Ø8mm
- ▶ Lieferung im Etui inkl. Messuhr, Adapter (Paar) und Messtasterpaar Ø 20mm

- ▶ Works standard
- ▶ Carbon fibre bar, guiding elements made of chromed steel
- ▶ Extremely low weight, high strength of shape
- ▶ Reversible measuring direction
- ▶ Measuring way max. 20mm
- ▶ Interchangeable measuring inserts
- ▶ Dial gauge reading 0.01mm
- ▶ Adjustable tolerance marks
- ▶ Dial mounting hole Ø 8mm
- ▶ Delivered in a case incl. dial gauge, adapters (pair) and probe pair Ø 20mm



Messeinsatz frei beweglich durch neue Messtiefenanschläge für größtmögliche Messgenauigkeit.

Measuring inserts free movable due to new designed measuring depth stop assure high precision measurements.

No. 1399 2..

47x16mm

Messrichtungsumkehr rückseitig  
 Reversible measuring direction backside



Beweglicher Taster, konstante Messkraft  
 Movable jaw, constant measuring force

Aufnahme für Standardtaster Ø 8mm  
 Mounting hole for standard probes Ø 8mm

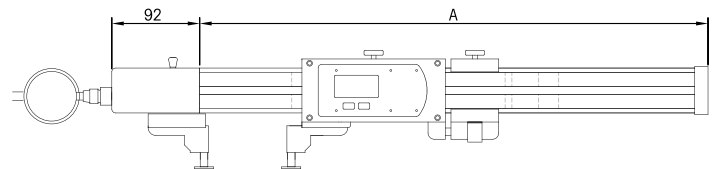

**Anwendungen:**

- ▶ Prüfen von Innen- und Außenmaßen, mit Sondermess-einsätzen auch in Nuten und Einstichen
- ▶ Mit Messarme Nr. 1851 810 können alle Standard-Taster mit Gewinde M2,5 oder Schaft Ø3,5mm montiert werden
- ▶ Gewindemessung mit Gewindeflankeneinsätzen Schaft Ø3,5mm Nr. 2048 5.. / 2048 6..
- ▶ Verzahnungsmessung mit Messkugeln im Halter Nr. 2050 3.. und Adapterbolzen Nr. 1390 311

**Application:**

- ▶ Inside and outside measurements, with special measuring inserts also in slots and recesses
- ▶ All standard measuring inserts with connection thread M2.5 or shaft Ø3.5mm can be mounted with measuring arms no. 1851 810
- ▶ Thread measurements with thread inserts shaft Ø 3.5mm No. 2048 5.. / 2048 6..
- ▶ Gear tooth measurements with measuring balls in holder No. 2050 3.. and adaptor bolts No. 1390 311

No. 1851 810

Messarme  
 measuring arms



mm	A mm	mm	kg	Nº
1000	1120	47 x 16	2,3	1399 204
1500	1620	47 x 16	2,8	1399 205
2000	2120	47 x 16	3,3	1399 206
2500	2620	47 x 16	3,8	1399 207
3000	3120	47 x 16	4,3	1399 208

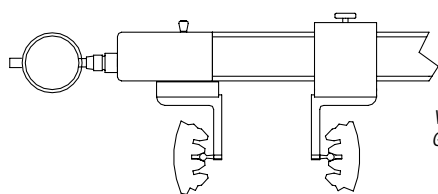
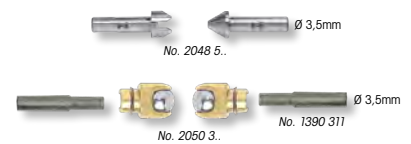

Verzahnung innen / außen  
 Gear tooth inside / outside

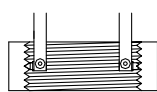
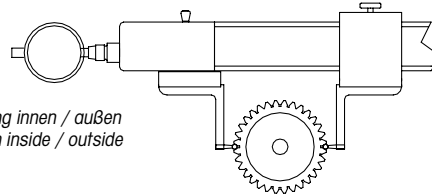

Gewinde innen / außen  
 Thread inside / outside

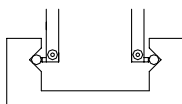
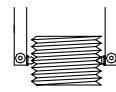

Nuten und Einstiche innen / außen  
 slots and recesses inside / outside

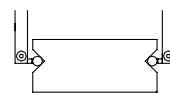

Messeinsätze siehe Seite 6.36 / Probes see page 6.36

**Digital-Vergleichsmessgeräte CARBON für Innen- und Außenmessung**

**Digital comparative measuring instrument CARBON for inside and outside measurements**



TOP



CARBON

- ▶ Werksnorm
- ▶ Sylvac System
- ▶ Stange aus Kohlefaser, Führungselemente aus Stahl verchromt
- ▶ extrem geringes Gewicht, hohe Formstabilität
- ▶ großes LCD Display, Ablesung 0,01mm
- ▶ Feststellschraube und Feineinstellung
- ▶ Messrichtungsumkehr
- ▶ Messweg max. 20mm
- ▶ Messeinsätze auswechselbar
- ▶ Messuhrablesung 0,01mm
- ▶ Toleranzmarken einstellbar
- ▶ Messuhraufnahme Ø8mm
- ▶ Lieferung im Etui inkl. Messuhr, Adapter (Paar) und Messtasterpaar Ø 20mm

- ▶ Works standard
- ▶ Sylvac System
- ▶ Carbon fibre bar, Guiding elements made of chrome steel
- ▶ Extremely low weight, high strength of shape
- ▶ Large LCD display, reading 0.01mm
- ▶ Locking screw and fine adjustment
- ▶ Reversible measuring direction
- ▶ Measuring way max. 20mm
- ▶ Interchangeable measuring inserts
- ▶ Dial gauge reading 0.01mm
- ▶ Adjustable tolerance marks
- ▶ Dial mounting hole Ø 8mm
- ▶ Delivered in a case incl. Dial gauge, adapters (pair) and probe pair Ø 20mm



Messeinsatz frei beweglich durch neue Messtiefenanschlüsse für größtmögliche Messgenauigkeit.

Measuring inserts free movable due to new designed measuring depth stop assure high precision measurements.

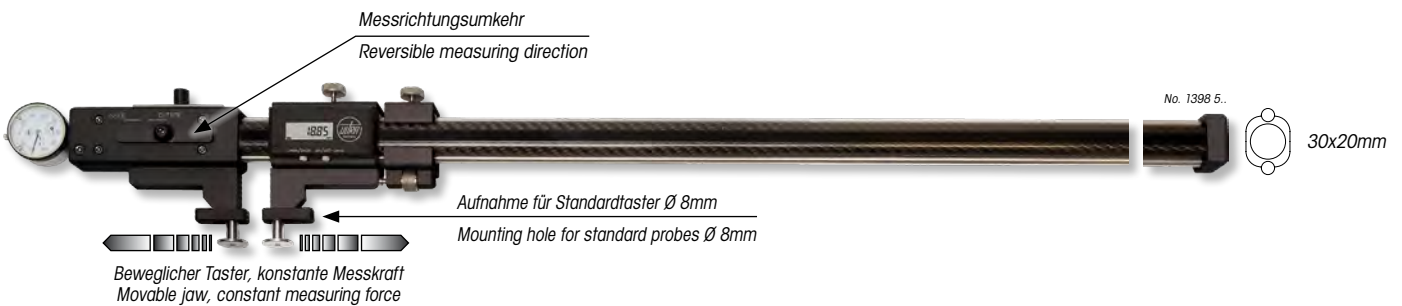

**Funktion:**

- ▶ Ein/Aus
- ▶ mm/inch Umschaltung
- ▶ 0-Punkt an jeder Position
- ▶ ± Preset Funktion
- ▶ Hold Funktion
- ▶ Datenausgang Opto

**Function:**

- ▶ On/Off
- ▶ mm/inch commutation
- ▶ Zero setting at any position
- ▶ ± preset function
- ▶ Hold function
- ▶ Data output Opto

**Anwendungen:**

- ▶ Prüfen von Innen- und Außenmaßen, mit Sondermess-einsätzen auch in Nuten und Einstichen
- ▶ Mit Messarme Nr. 1851 810 können alle Standard-Taster mit Gewinde M2,5 oder Schaft Ø3,5mm montiert werden
- ▶ Gewindemessung mit Gewindeflankeneinsätzen Schaft Ø3,5mm Nr. 2048 5.. / 2048 6..
- ▶ Verzahnungsmessung mit Messkugeln im Halter Nr. 2050 3.. und Adapterbolzen Nr. 1390 311

**Application:**

- ▶ Inside and outside measurements, with special measuring inserts also in slots and recesses
- ▶ With measuring arms no. 1851 810 all standard measuring inserts with connection thread M2.5 or shaft Ø3.5mm can be mounted
- ▶ Thread measurements with thread inserts shaft Ø 3.5mm No. 2048 5.. / 2048 6..
- ▶ Gear tooth measurements with measuring balls in holder No. 2050 3.. and adaptor bolts No. 1390 311

**Handhabung Innenmessung:**

- ▶ Das Messgerät wird z.B. mit einem Einstellring Ø 50mm voreingestellt in dem die Digitalanzeige mit Preset auf 50mm eingestellt wird und die Messuhr auf den Wert 0 (Umkehrpunkt !) Durch Verfahren des beweglichen Schnabels kann nun jedes beliebige Nennmaß innerhalb des gesamten Messbereichs über die Digitalanzeige eingestellt werden. Die Abweichung des Werkstücks zum eingestellten Wert (Digitalanzeige) wird an der Messuhr in 1/100mm abgelesen (Umkehrpunkt !).

**Operation inside measurement:**

- ▶ The setting of the instrument will be made by using for example a Ø 50mm setting ring gauge, the digital display will be preset to the value 50mm and the dial gauge will be adjusted to 0 (reversing point !). By sliding the movable jaw (electronic device) you can preset now each nominal value up to the complete measuring range of the instrument – the deviation of your work piece, in comparison to your preset value at your digital display, will be read at the dial gauge in 1/100mm (reversing point !).

**Vorteil:** Ein Einstellmeister reicht aus, um das Gerät, innerhalb des Messbereiches, auf ein beliebiges Werkstückmaß vor einzustellen.

**Advantage:** One setting master is sufficient to adjust the instrument and to be able to use it after that for any size within the instrument capacity.

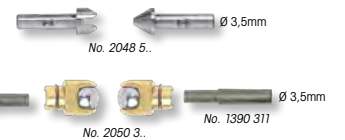
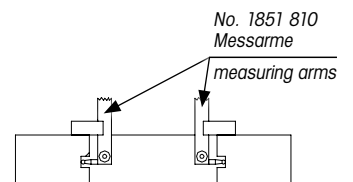
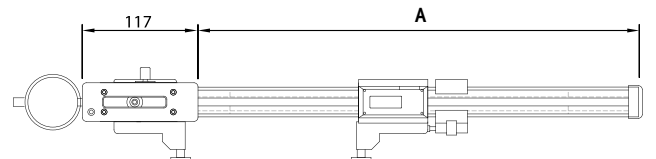

mm	A mm	mm	kg	Nº
400	550	30 x 20	1,4	1398 501
600	750	30 x 20	1,9	1398 502
800	950	30 x 20	2,4	1398 503
Datenkabel RS232 (2m) / Data cable RS232 (2m)				1850 203
Datenkabel USB (2m) / Data cable USB (2m)				1850 204

Messeinsätze siehe Seite 6.36 / Probes see page 6.36



**Digital-Vergleichsmessgeräte CARBON für Innen- und Außenmessung**

**Digital comparative measuring instrument CARBON for inside and outside measurements**



- ▶ Werksnorm
- ▶ Sylvac System
- ▶ Stange aus Kohlefaser, Führungselemente aus Stahl verchromt
- ▶ extrem geringes Gewicht, hohe Formstabilität
- ▶ großes LCD Display, Ablesung 0,01mm
- ▶ Feststellschraube und Feineinstellung
- ▶ Messrichtungsumkehr
- ▶ Messweg max. 20mm
- ▶ Messeinsätze auswechselbar
- ▶ Messuhrablesung 0,01mm
- ▶ Toleranzmarken einstellbar
- ▶ Messuhraufnahme Ø8mm
- ▶ Lieferung im Etui inkl. Messuhr, Adapter (Paar) und Messtasterpaar Ø 20mm

- ▶ Works standard
- ▶ Sylvac System
- ▶ Carbon fibre bar, Guiding elements made of chrome steel
- ▶ Extremely low weight, high strength of shape
- ▶ Large LCD display, reading 0.01mm
- ▶ Locking screw and fine adjustment
- ▶ Reversible measuring direction
- ▶ Measuring way max. 20mm
- ▶ Interchangeable measuring inserts
- ▶ Dial gauge reading 0.01mm
- ▶ Adjustable tolerance marks
- ▶ Dial mounting hole Ø 8mm
- ▶ Delivered in a case incl. Dial gauge, adapters (pair) and probe pair Ø 20mm



Messeinsatz frei beweglich durch neue Messtiefenanschlüsse für größtmögliche Messgenauigkeit.

Measuring inserts free movable due to new designed measuring depth stop assure high precision measurements.

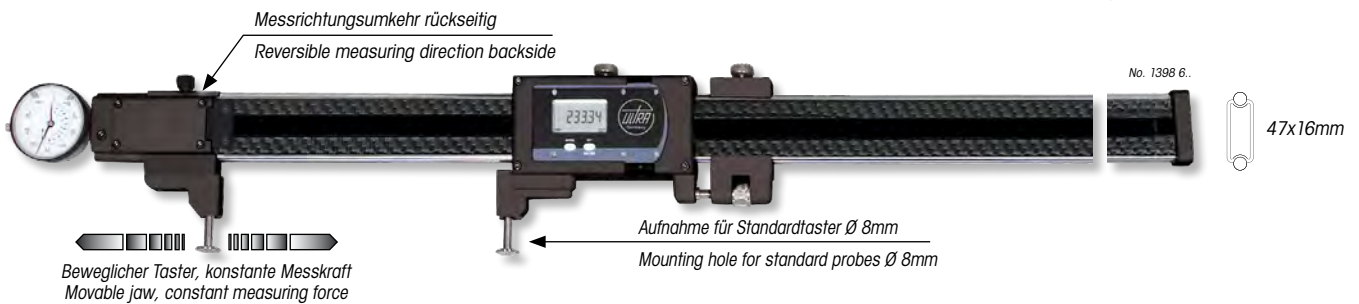

**Funktion:**

- ▶ Ein/Aus
- ▶ mm/inch Umschaltung
- ▶ 0-Punkt an jeder Position
- ▶ ± Preset Funktion
- ▶ Hold Funktion
- ▶ Datenausgang Opto

**Funktion:**

- ▶ On/Off
- ▶ mm/inch commutation
- ▶ Zero setting at any position
- ▶ ± preset function
- ▶ Hold function
- ▶ Data output Opto

**Anwendungen:**

- ▶ Prüfen von Innen- und Außenmaßen, mit Sondermess-einsätzen auch in Nuten und Einstichen
- ▶ Mit Messarme Nr. 1851 810 können alle Standard-Taster mit Gewinde M2,5 oder Schaft Ø3,5mm montiert werden
- ▶ Gewindemessung mit Gewindeflankeneinsätzen Schaft Ø3,5mm Nr. 2048 5.. / 2048 6..
- ▶ Verzahnungsmessung mit Messkugeln im Halter Nr. 2050 3.. und Adapterbolzen Nr. 1390 311

**Application:**

- ▶ Inside and outside measurements, with special measuring inserts also in slots and recesses
- ▶ With measuring arms no. 1851 810 all standard measuring inserts with connection thread M2.5 or shaft Ø3.5mm can be mounted
- ▶ Thread measurements with thread inserts shaft Ø 3.5mm No. 2048 5.. / 2048 6..
- ▶ Gear tooth measurements with measuring balls in holder No. 2050 3.. and adaptor bolts No. 1390 311

**Handhabung Innenmessung:**

- ▶ Das Messgerät wird z.B. mit einem Einstellring Ø 50mm voreingestellt in dem die Digitalanzeige mit Preset auf 50mm eingestellt wird und die Messuhr auf den Wert 0 (Umkehrpunkt !) Durch Verfahren des beweglichen Schabfels kann nun jedes beliebige Nennmaß innerhalb des gesamten Messbereichs über die Digitalanzeige eingestellt werden. Die Abweichung des Werkstücks zum eingestellten Wert (Digitalanzeige) wird an der Messuhr in 1/100mm abgelesen (Umkehrpunkt !).

**Operation inside measurement:**

- ▶ The setting of the instrument will be made by using for example a Ø 50mm setting ring gauge, the digital display will be preset to the value 50mm and the dial gauge will be adjusted to 0 (reversing point !). By sliding the movable jaw (electronic device) you can preset now each nominal value up to the complete measuring range of the instrument – the deviation of your work piece, in comparison to your preset value at your digital display, will be read at the dial gauge in 1/100mm (reversing point !).

**Vorteil:** Ein Einstellmeister reicht aus, um das Gerät, innerhalb des Messbereiches, auf ein beliebiges Werkstückmaß voreinzustellen.

**Advantage:** One setting master is sufficient to adjust the instrument and to be able to use it after that for any size within the instrument capacity.

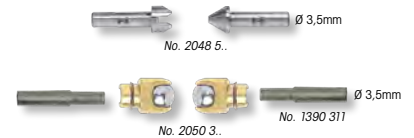
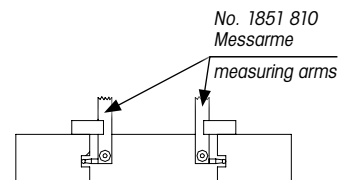
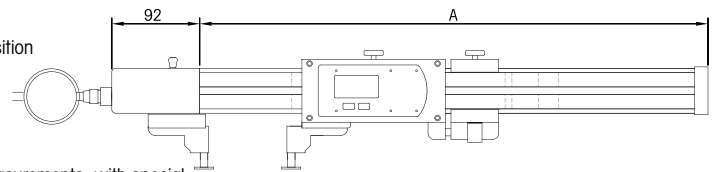

ꞑ mm	A mm	ꞑ mm	ꞑ kg	Nº
1000	1300	47 x 16	2,6	1398 604
1500	1800	47 x 16	3,1	1398 605
2000	2300	47 x 16	3,6	1398 606
2500	2800	47 x 16	4,1	1398 607
3000	3300	47 x 16	4,6	1398 608
Datenkabel RS232 (2m) / Data cable RS232 (2m)				1850 203
Datenkabel USB (2m) / Data cable USB (2m)				1850 204

Messeinsätze siehe Seite 6.36 / Probes see page 6.36

**Messeinsätze für CARBON Vergleichsmessgeräte mit Einspannschaft Ø 8mm, Paar**

**Probes for CARBON comparativ meas. instruments with clamping shaft Ø 8mm, pair**



**Gehärtet  
Hardened**

- ▶ aus gehärtetem Spezialstahl
- ▶ Lieferung paarweise verpackt

- ▶ Hardened special steel
- ▶ Delivered in a package (pair)

**I** Andere Messtaster auf Anfrage.

**I** Other measurings inserts on request.

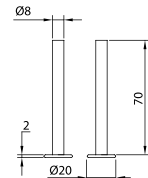
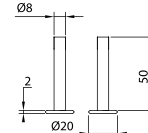
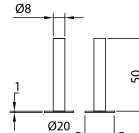
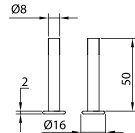
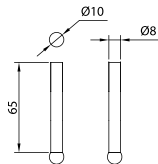
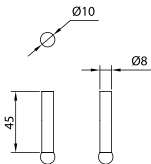
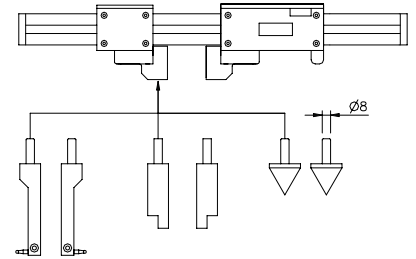

Nº	1390 301	1390 302	1390 303	1390 312	1390 313	1390 304
----	----------	----------	----------	----------	----------	----------

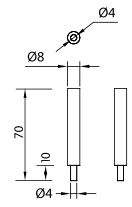
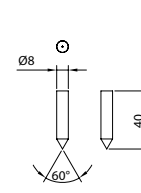
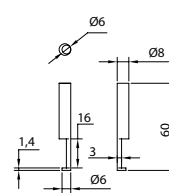
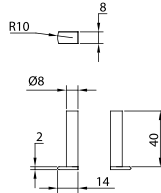
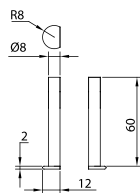
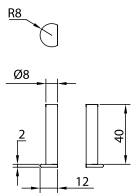

Nº	1390 305	1390 306	1390 307	1390 308	1390 309	1390 314
----	----------	----------	----------	----------	----------	----------

Aufnahme für Standardtaster Ø 3,5mm oder Messuhr taster Gewinde M2,5  
Mounting hole for standard probes Ø 3.5mm or dial gauges inserts M2.5

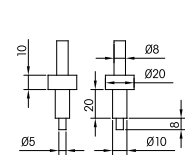
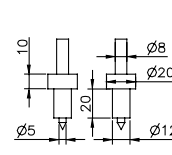
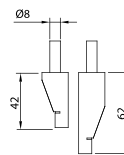
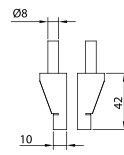
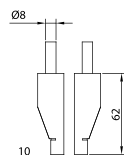
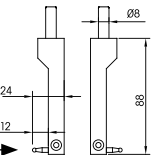

Nº	1851 810	1851 812	1851 813	1851 814	1851 816	1851 818
----	----------	----------	----------	----------	----------	----------

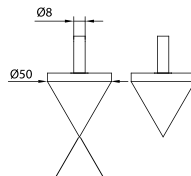
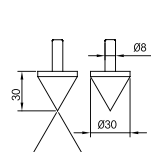
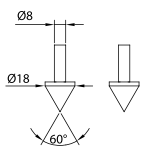

Taster für Gewindemessung auf Anfrage.

Probes for thread measurement on request.

Nº	1851 819	1851 815	1851 820
----	----------	----------	----------

**Tablet für Messtaster**

**Tray for measuring probes**



- ▶ zur Aufbewahrung von max. 12 Tastern
- ▶ aus Plexiglas
- ▶ Bohrungen für Schaft Ø 8mm
- ▶ Lieferung einzeln verpackt, ohne Taster

- ▶ For storing of max. 12 probes
- ▶ Made of plexiglass
- ▶ Holes for shaft Ø 8mm
- ▶ Delivered in individual packages





No. 1390 351

L mm	M kg	Nº
150 x 100 x 25	0,1	1390 351

**Halterungen für CARBON Vergleichsmessgeräte, Paar**

**Holders for CARBON comparative measuring instruments, pair**

  **ALUMINIUM**

- ▶ zum Befestigen von CARBON Vergleichsmessgeräten an Vorrichtungen und Messplatten etc.
- ▶ Material Aluminium
- ▶ Lieferung paarweise verpackt

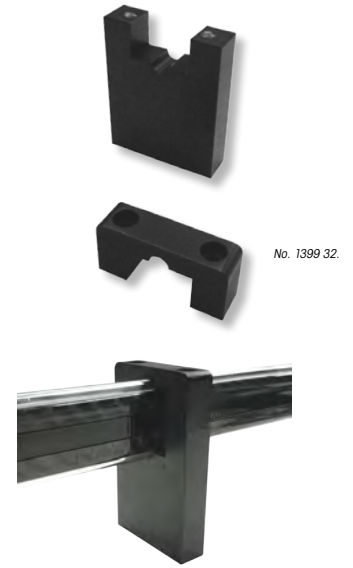
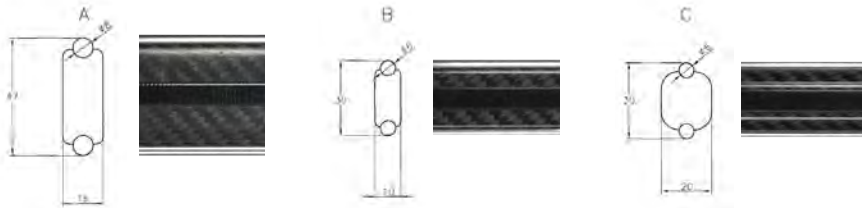

- ▶ Mounting of CARBON comparative measuring instruments on measuring devices or measuring plates etc.
- ▶ Aluminium
- ▶ Delivered in a package (pair)

Profil Typ	∅ mm	l mm	h kg	Nº
A	48 x 16	80 x 42 x 10	0,1	1399 321
B + C	30 x 10	62 x 42 x 10	0,1	1399 322



**Messtisch für CARBON-Vergleichsmessgeräte**

**Measuring table for CARBON comparative measuring instruments**

  **Gehärtet Hardened**

- ▶ passend für Geräte ≤ 800mm Messbereich und Stangenquerschnitt 30x20mm
- ▶ Messfläche aus rostfreiem, gehärtetem Stahl
- ▶ Lieferung einzeln verpackt, ohne Vergleichsmessgerät

- ▶ Suitable for instruments ≤ 730mm measuring range and bar cross section 30x20mm
- ▶ Hardened measuring surfaces made of stainless steel
- ▶ Delivered in individual packages without comparative meas. instrument



- Anwendungen:**
- ▶ wie ULTRA QUICK CHECK
  - ▶ Prüfen von Innen- und Außenmaßen, mit Sondermess-einsätzen auch in Nuten und Einstichen
  - ▶ Verzahnungsmessung mit Messkugeln im Halter Nr. 2050 3.. und Adapterbolzen Nr. 1390 311

- Application:**
- ▶ similar to ULTRA QUICK CHECK
  - ▶ Inside and outside measurements, with special measuring inserts also in slots and recesses
  - ▶ Gear tooth measurements with measuring balls in holder No. 2050 3..) and adaptor bolts No. 1390 311

l mm	h kg	Nº
450 x 148 x 108	3,0	1399 400
850 x 148 x 108	5,0	1399 401

**Tiefenanschlüge für Messeinsätze mit Einspannschaft ∅ 8mm, Paar**

**Depth stop for probes with clamping shaft ∅ 8mm, pair**



- ▶ Zum Einstellen der Messtiefe
- ▶ Klemmung in beliebiger Position auf dem Schaft der Messeinsätze
- ▶ Erleichtert die Umkehrpunktsuche bei Vergleichsmessgeräten
- ▶ rostfreier Stahl, mit Klemmschraube
- ▶ Lieferung paarweise verpackt

- ▶ Adjusting the measuring depth
- ▶ Clamping on each position at the probe shaft
- ▶ Easy handling during checking the reversing point of comparative measuring instruments.
- ▶ Stainless steel with clamping screw
- ▶ Delivered in a package (pair)

h mm	l mm	h kg	Nº
23	34 x 14 x 8	0,052	1399 331
34	45 x 14 x 8	0,064	1399 332



**Vergleichsmessgeräte CARBON  
für Innen- und Außenmessung**

**Comparative measuring instrument CARBON  
for inside and outside measurements**



**CARBON**

Länge ≤4000mm  
Length

- ▶ Werksnorm
- ▶ Stange aus Kohlefaser, Führungselemente aus Stahl verchromt
- ▶ extrem geringes Gewicht, hohe Formstabilität
- ▶ Messrichtungsumkehr
- ▶ Messweg max. 12mm
- ▶ Messuhraufnahme Ø8mm
- ▶ Messbereich bis max. 4000mm
- ▶ Lieferung im Koffer ohne Messuhr

Zur Angebotserstellung senden Sie uns bitte eine detaillierte Beschreibung Ihrer Messaufgabe.

- ▶ Works standard
- ▶ Carbon fibre bar, guiding elements made of chrome steel
- ▶ Extremely low weight, high strength of shape
- ▶ Reversible measuring direction
- ▶ Measuring way max. 12mm
- ▶ Dial mounting hole Ø8mm
- ▶ Measuring range max. 4000mm
- ▶ Delivered in box without dial gauge

Please send us detailed description of your measuring task.



**BOWERS GROUP**



## Digital-Kurbelwellen-Prüfgeräte

## Digital crankshaft testing instruments



- ▶ Werksnorm
- ▶ zum Prüfen der Durchbiegung an Kurbelwellen
- ▶ großes LCD Display
- ▶ Zentrierspitzen 60° gehärtet
- ▶ Hartmetallmessflächen Ø8mm
- ▶ nichtdrehende Spindel
- ▶ Spindelsteigung 1mm
- ▶ Spindelklemmung
- ▶ Handwärmeschutz
- ▶ Lieferung im Holzetui

- ▶ Works standard
- ▶ For checking crankshaft deflections
- ▶ Large LCD display
- ▶ Centring points 60° hardened
- ▶ Tungsten carbide-tipped measuring faces Ø8mm
- ▶ Non-turning spindle
- ▶ Spindle pitch 1mm
- ▶ Spindle clamping
- ▶ Insulated pads
- ▶ Delivered in a case

- Funktionen:**
- ▶ Ein/Aus
  - ▶ mm/inch Umschaltung
  - ▶ 0-Punkt an jeder Position
  - ▶ Preset Funktion
  - ▶ Toleranzwerteingabe
  - ▶ Hold Funktion
  - ▶ Datenausgang Opto

- Functions:**
- ▶ On/Off
  - ▶ mm/inch commutation
  - ▶ Zero setting at any position
  - ▶ Preset function
  - ▶ Tolerance input
  - ▶ Hold function
  - ▶ Data output Opto

mm	mm	inch	kg	Nº
94 – 403	0,01 / 0,001	.0005 / .00005	1,0	1375 101
Datenkabel RS232 (2m) / Data cable RS232 (2m)				1850 203
Datenkabel USB (2m) / Data cable USB (2m)				1850 204



## Kurbelwellen-Prüfgeräte

## Crankshaft testing instruments

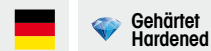

- ▶ Werksnorm
- ▶ zum Prüfen der Durchbiegung an Kurbelwellen
- ▶ Zentrierspitzen 90° gehärtet
- ▶ Lieferung im Holzetui inkl. Messuhr

- ▶ Works standard
- ▶ For checking crankshaft deflections
- ▶ Centring points 90° hardened
- ▶ Delivered in wooden box incl. dial gauge

**1376 1.. :**  
mit Gegengewicht

**1376 1.. :**  
With counter weight

**1377 1.. :**  
Messuhr beidseitig ablesbar

**1377 1.. :**  
Indicator reading on both sides

mm	mm	Zifferblatt / Dial Ø mm	kg	Nº
45 – 150	0,01	28	0,4	1376 101
60 – 300	0,01	40	1,1	1376 102
60 – 500	0,01	40	1,2	1376 103
49 – 363	0,01	39	0,5	1377 101
98 – 461	0,01	39	0,6	1377 102



## Zentriergerät CENTRICATOR

## Centring device CENTRICATOR



- ▶ Werksnorm
- ▶ horizontal und vertikal einsetzbar
- ▶ eingebaute, nichtdrehende Messuhr
- ▶ Zentrierfehler max. 0,002mm
- ▶ Lieferung im Holzetui (Nr. 1372 101 in Styro-Box)

### Lieferumfang:

- ▶ Zentriergerät
- ▶ Taster gerade Kugel Ø 5mm
- ▶ Taster gebogen Kugel Ø 5mm (nur Nr. 1372 101)
- ▶ Schraubendreher SW 3
- ▶ Betriebsanleitung

### 1372 101 :

Einspannschaft fest Ø 16mm

### 1373 101 :

verstellbarer Schlitten, ohne Einspannschaft

- ▶ Works standard
- ▶ Horizontal and vertical application
- ▶ Integrated non-turning dial gauge
- ▶ Centring error max. 0.002mm
- ▶ Delivered in wooden box (No. 1372 101 in Styro-Box)

### Scope of delivery:

- ▶ Centring instrument
- ▶ Straight probe, ball Ø 5mm
- ▶ Bent probe, ball Ø 5mm (only No. 1372 101)
- ▶ Screwdriver SW 3
- ▶ Operating manual

### 1372 101 :

Fixed clamping shaft Ø 16 mm

### 1373 101 :

Adjustable slides without clamping shaft

! Die Anwendungsbereiche beziehen sich auf die im Lieferumfang enthaltenen Taster.

! The application ranges apply to the probe included in the scope of delivery.

≤ mm	innen / inside Ø mm	außen / outside Ø mm	plan / plane Ø mm	kg	Nº
0,01	6 – 125	0 – 125	120 – 160	1,5	1372 101
0,01	6 – 220	0 – 150	90 – 280	2,2	1373 101



No. 1373 101



No. 1372 101



No. 1372 101

## Sondertaster für CENTRICATOR

## Special probes for CENTRICATOR



- ▶ Lieferung einzeln verpackt

- ▶ Delivered in individual packages

A: Werte für CENTRICATOR No. 1372 101

B: Werte für CENTRICATOR No. 1373 101

A: Values for CENTRICATOR No. 1372 101

B: Values for CENTRICATOR No. 1373 101

### 1374 306 :

Kantensucher mit Magnet

### 1374 306 :

Edge finder with magnet

Typ Type	Ø mm	innen / Ø mm	A	mm	außen / Ø mm	B	mm	Nº
Anwendung innen / Inside use								
Taster gerade Straight probe	Ø 5	6 – 125	55	6 – 220	55			1374 300
Taster gerade Straight probe	Ø 1,6	2 – 125	55	2 – 220	55			1374 301
Taster winkelig Angular probe	Ø 2,5	-	-	20 – 220	55			1374 302
Verlängerung Extension	-	-	-	2 – 400	150			1374 304
Anwendung außen / Outside use								
Taster gerade Straight probe	Ø 5	0 – 125	20	0 – 150	55			1374 300
Taster winkelig Angular probe	Ø 2,5	-	-	0 – 220	55			1374 302
Verlängerung Extension	-	-	-	0 – 300	150			1374 304
Anwendung Planfläche / Plain surface use								
Plantasteinsatz Plain probe	Ø 5	-	-	0 – 90	28			1374 303
Taster gerade Straight probe	Ø 5	120 – 160	-	90 – 280	40			1374 300
Taster winkelig Angular probe	Ø 2,5	-	-	90 – 280	40			1374 302
Verlängerung Extension	-	-	-	280 – 400	-			1374 304

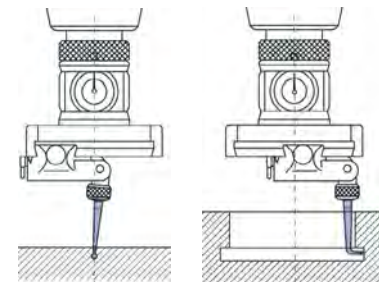

No. 1374 301

No. 1374 302

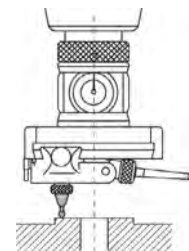

No. 1374 303

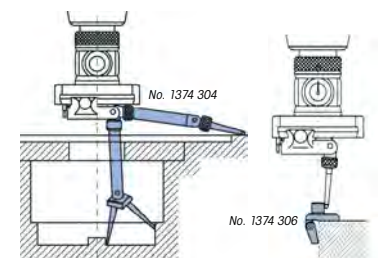

No. 1374 304

No. 1374 306

**Einspannschäfte für CENTRICATOR Nr. 1373 101**

**Clamping shafts for CENTRICATOR No. 1373 101**

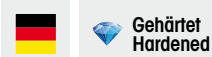

- ▶ Spezialstahl gehärtet
- ▶ Lieferung einzeln verpackt

- ▶ Tool steel hardened
- ▶ Delivered in individual packages

! Andere Ausführungen sowie Anzugsgewinde in Zoll auf Anfrage.

! Other versions and clamping threads in inches on request.



No. 1374 111

Typ Type	Gewinde Thread	⚖ kg	Nº
zylindrisch Ø 16mm Cylindrical Ø 16 mm	-	0,5	1374 110
zylindrisch Ø 20mm Cylindrical Ø 20 mm	-	0,6	1374 111

**Zentriergerät DIACATOR**

**Centring devices DIACATOR**



- ▶ Werksnorm
- ▶ horizontal und vertikal einsetzbar
- ▶ eingebaute, nichtdrehende Messuhr
- ▶ Zentrierfehler max. 0,01mm
- ▶ Lieferung im Holzetui

- ▶ Works standard
- ▶ Horizontal and vertical application
- ▶ Integrated non-turning dial indicator
- ▶ Centring error max. 0.01mm
- ▶ Delivered in a wooden box

- Lieferumfang:
- ▶ Zentriergerät
  - ▶ Einspannschäft MK1
  - ▶ Einspannschäft Ø 10, 12 und 16mm
  - ▶ Taster für kleine Bohrungen
  - ▶ Taster gebogen 25mm Kugel Ø 3,6mm
  - ▶ Taster gebogen 48mm Kugel Ø 3,6mm
  - ▶ Sechskantschlüssel SW 2
  - ▶ Betriebsanleitung

- Scope of delivery:
- ▶ Centring instrument
  - ▶ Clamping shaft MK1
  - ▶ Clamping shaft Ø 10, 12 and 16mm
  - ▶ Probe for small bores
  - ▶ Bent probe 25mm, ball Ø 3.6mm
  - ▶ Bent probe 48mm, ball Ø 3.6mm
  - ▶ Fixed spanner SW 2
  - ▶ Operating manual

! Die Anwendungsbereiche beziehen sich auf die im Lieferumfang enthaltenen Taster.

! The application ranges apply to the probe included in the scope of delivery.

≤ mm	⌀ innen / inside Ø mm	⌀ außen / outside Ø mm	⚖ kg	Nº
0,01	5 – 110	1,5 – 120	1,5	1384 101



No. 1384 101

**Sondertaster für DIACATOR**

**Special probes for DIACATOR**



- ▶ für vertikalen Einsatz
- ▶ Kugel Ø 6mm
- ▶ Lieferung einzeln verpackt

- ▶ For vertical application
- ▶ Ball Ø 6mm
- ▶ Delivered in individual packages

Typ Type	l mm	⌀ Ø mm	Fehler / Error max. mm	⚖ kg	Nº
Anwendung innen / Inside use					
Taster gerade Straight probe	100	20 – 180	0,01	0,01	1384 201
	125	20 – 220	0,015	0,013	1384 202
	150	20 – 260	0,018	0,016	1384 203
	200	20 – 340	0,02	0,2	1384 204



No. 1384 201

## Zentriergerät CENTRO

## CENTRO centring device



- ▶ Werksnorm
- ▶ horizontal und vertikal einsetzbar
- ▶ eingebaute, nichtdrehende Messuhr
- ▶ Zentrierfehler max. 0,003mm
- ▶ Gehäuse Ø 63mm
- ▶ Lieferung in Styroporbox

### Lieferumfang:

- ▶ Zentriergerät
- ▶ Einspannschaft Ø 16mm
- ▶ Taster gerade Kugel Ø 5mm
- ▶ Betriebsanleitung

**!** Die Anwendungsbereiche beziehen sich auf die im Lieferumfang enthaltenen Taster.

- ▶ Works standard
- ▶ Horizontal and vertical application
- ▶ Integrated non-turning dial indicator
- ▶ Centring error max. 0.003mm
- ▶ Housing Ø 63mm
- ▶ Delivered in styrofoam box

### Scope of delivery:

- ▶ Centring instrument
- ▶ Clamping shaft Ø 16mm
- ▶ Straight probe, ball Ø 5mm
- ▶ Operating manual

**!** The application ranges apply to the probe included in the scope of delivery.

≤ mm	innen / inside Ø mm	außen / outside Ø mm	kg	Nº
0,01	6 – 125	0 – 125	1,5	1384 501



No. 1384 501

## Sondertaster für CENTRO

## Special probes for CENTRO



- ▶ Lieferung einzeln verpackt

- ▶ Delivered in individual packages

Typ Type	Kugel / ball Ø mm	innen / Ø mm	kg	Nº
Anwendung innen / Inside use				
Taster gerade / Straight probe	2	3 – 125	0,01	1384 603
Taster gerade / Straight probe	5	6 – 125	0,013	1384 601
Anwendung außen / Outside use				
Taster gebogen / Bent probe	5	0 – 125	0,016	1384 602



No. 1384 601



No. 1384 602

## 3D-Taster

## 3D adjusting device



- ▶ Werksnorm
- ▶ für Fräsmaschinen
- ▶ Schutzart IP 67
- ▶ horizontal und vertikal einsetzbar
- ▶ Maschinen 0-Punkt einstellen
- ▶ Längenmessung
- ▶ beliebige Anstrichung (x/y/z)
- ▶ Taster mit Sollbruchstelle
- ▶ Lieferung einzeln verpackt

### Lieferumfang:

- ▶ 3D Taster
- ▶ Taster mit Hartmetallkugel Ø 3mm
- ▶ Betriebsanleitung

- ▶ Works standard
- ▶ For milling machines
- ▶ Protection class IP 67
- ▶ Horizontal and vertical application
- ▶ Machine zero adjusting
- ▶ Length measuring
- ▶ Free alignment of all axes (x/y/z)
- ▶ Probe with break point
- ▶ Delivered in individual packages

### Scope of delivery:

- ▶ 3D adjusting device
- ▶ Probe tungsten carbide ball tip Ø 3mm
- ▶ Operating manual

≤ mm	A Ø mm	B Ø mm	C mm	kg	Nº
0,01	12	43	90,5	0,6	1385 800
Taster kurz / short probe Ø 3x27mm					1385 901
Taster lang / long probe Ø 6x62mm					1385 902



No. 1385 901



No. 1385 902

No. 1385 800



- A = Einspannschaft Ø  
Clamping shaft Ø
- B = Anzeige Ø ca.  
Display Ø approx.
- C = Länge ohne Schaft  
Length without shaft



## 3D-Taster

## 3D adjusting device



- ▶ Werksnorm
- ▶ für Fräs- und Erodiermaschinen
- ▶ horizontal und vertikal einsetzbar
- ▶ Maschinen O-Punkt einstellen
- ▶ Längenmessungen
- ▶ beliebige Antastrichtung (x/y/z)
- ▶ isolierter Taster mit Sollbruchstelle
- ▶ Lieferung in Styroporbox

Lieferumfang:

- ▶ 3D-Taster
- ▶ Taster Kugel Ø 4mm
- ▶ Innensechskantschlüssel SW 2
- ▶ Stiftschlüssel Ø 1,5
- ▶ Betriebsanleitung

- ▶ Works standard
- ▶ For milling and erosion machines
- ▶ Horizontal and vertical application
- ▶ Machine zero setting
- ▶ Length measuring
- ▶ Free alignment of all axes (x/y/z)
- ▶ Insulated probe with break point
- ▶ Delivered in styrofoam box

Scope of delivery:

- ▶ 3D adjusting device
- ▶ Probe ball tip Ø 4mm
- ▶ Allen key SW 2
- ▶ Wrench Ø 1.5
- ▶ Operating manual

**1385 1.. :**

Analogablesung

**1385 1.. :**

Analoge reading

**1385 501 :**

Digitalablesung

**1385 501 :**

Digital reading

! Einspannschaft Ø 16mm sowie SK 40 auf Anfrage.

! Clamping shaft Ø 16mm and SK 40 on request.

<math>\leq</math> mm	A Ø mm	B Ø mm	C mm	⚖ kg	Nº
0,01	10	40	96	1,0	1385 100
0,01	20	63	113	1,2	1385 101
0,005	20	63	113	1,2	1385 501



A = Einspannschaft Ø / Clamping shaft Ø  
B = Anzeige Ø ca. / Display Ø approx.  
C = Länge ohne Schaft / Length without shaft

## Ersatztaster für 3D-Taster

## Spare probe for 3D adjusting device



- ▶ Keramik-Isolator mit Sollbruchstelle
- ▶ Lieferung einzeln verpackt

- ▶ Ceramic-insulated with break point
- ▶ Delivered in individual packages

Typ Type	Kugel / Ball Ø mm	l-l mm	⚖ kg	Nº
Taster kurz / Short probe	4	25	0,01	1385 201
Taster lang / Long probe	8	65	0,015	1385 202

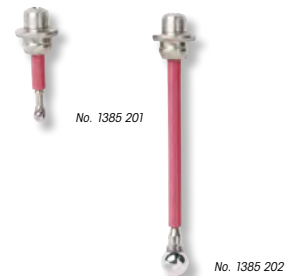

## 3D-Taster STANDARD

## 3D adjusting device STANDARD



- ▶ Werksnorm
- ▶ für Fräsmaschinen
- ▶ horizontal und vertikal einsetzbar
- ▶ Maschinen O-Punkt einstellen
- ▶ Längenmessung
- ▶ beliebige Antastrichtung (x/y/z)
- ▶ Taster mit Sollbruchstelle
- ▶ Lieferung im Koffer

Lieferumfang:

- ▶ 3D Taster
- ▶ Taster mit Hartmetallkugel Ø 3mm
- ▶ Betriebsanleitung

- ▶ Works standard
- ▶ For milling machines
- ▶ Horizontal and vertical application
- ▶ Machine zero adjusting
- ▶ Length measuring
- ▶ Free alignment of all axes (x/y/z)
- ▶ Probe with break point
- ▶ Delivered in a box

Scope of delivery:

- ▶ 3D adjusting device
- ▶ Probe tungsten carbide ball tip Ø 3mm
- ▶ Operating manual

<math>\leq</math> mm	A Ø mm	B Ø mm	C mm	⚖ kg	Nº
0,01	12	39	134	0,45	1385 851
Taster kurz / short probe Ø 3x27mm					1385 901
Taster lang / long probe Ø 6x62mm					1385 902

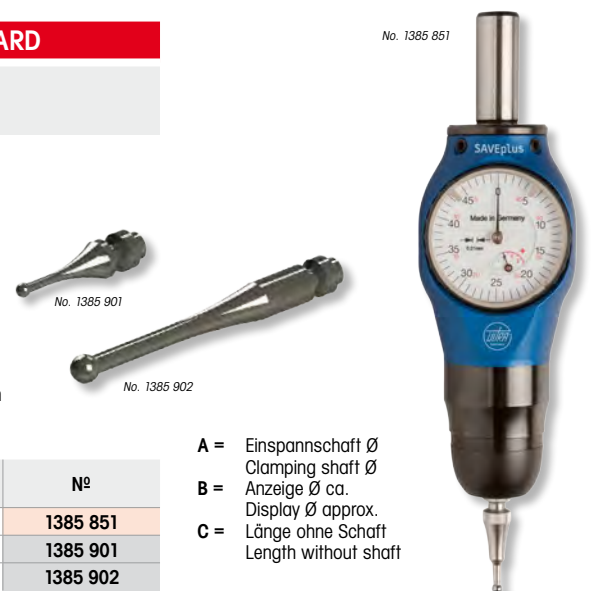

A = Einspannschaft Ø  
Clamping shaft Ø  
B = Anzeige Ø ca.  
Display Ø approx.  
C = Länge ohne Schaft  
Length without shaft

### 3D-Taster mit LED

### 3D adjusting device with LED



- ▶ Werksnorm
- ▶ für Bearbeitungsmaschinen
- ▶ horizontal und vertikal einsetzbar bei Kontakt der federnden Tastkugel mit dem Werkstück, leuchtet die LED
- ▶ Werkstück und Werkzeugaufnahme müssen elektrisch leitend miteinander verbunden sein
- ▶ Antastgenauigkeit  $\pm 0,005\text{mm}$
- ▶ Maschinen 0-Punkt setzen
- ▶ Taster Kugel  $\varnothing 10\text{mm}$
- ▶ Längenmessung
- ▶ beliebige Antastrichtung (x/y/z)
- ▶ Beim Antasten in Z-Achse muss die Bezugslänge im Voreinstellgerät ermittelt werden
- ▶ Lieferung im Koffer, inkl. Werksprüfbericht

- ▶ Works standard
- ▶ for machine tools
- ▶ Horizontal and vertical application. The LED glows when the probe ball-tip comes into contact with the workpiece
- ▶ Workpiece and tool mounting holes should be connected with each other for electrical conductivity
- ▶ Accuracy  $\pm 0.005\text{mm}$
- ▶ Machine zero setting
- ▶ Probe ball tip  $\varnothing 10\text{mm}$
- ▶ length measuring
- ▶ Free alignment of all axes (x/y/z)
- ▶ When using the z-axis the reference length has to be determined by a presetting instrument
- ▶ Delivered in a box, incl. Certificate



A $\varnothing$ mm	$\bar{m}$ kg	Nº
20	0,5	1385 701

### Kantentaster

### Edge finders



- ▶ horizontal und vertikal einsetzbar
- ▶ bei Gleichlauf des Ober- und Unterteils ist die Achsmittle erreicht
- ▶ Lieferung einzeln verpackt

- ▶ Horizontal and vertical application
- ▶ Axial centre is attained by the synchronous run of the upper and lower parts
- ▶ Delivered in individual packages

Genauigkeit Accuracy mm	Taster Probe $\varnothing$ mm	Schaft Shaft $\varnothing$ mm	$L$ mm	$\bar{m}$ kg	Nº
0,01	10	10	84	0,25	1391 101
0,01	4 / 10	10	90	0,25	1391 102

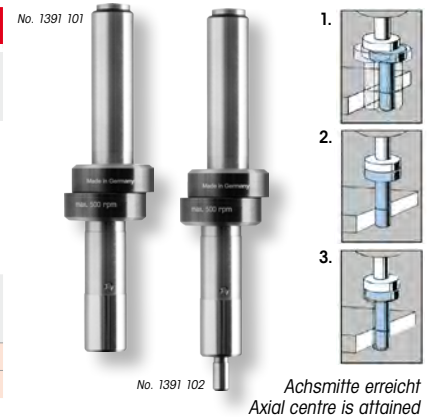

### Kantentaster mit LED

### Edge finders with LED



- ▶ horizontal und vertikal einsetzbar bei Kontakt der federnden Tastkugel mit dem Werkstück, leuchtet die LED
- ▶ Werkstück und Werkzeugaufnahme müssen elektrisch leitend miteinander verbunden sein
- ▶ Lieferung einzeln verpackt

- ▶ Horizontal and vertical application. The LED glows when the probe ball-tip comes into contact with the workpiece
- ▶ Workpiece and tool mounting holes should be connected with each other for electrical conductivity
- ▶ Delivered in individual packages

Genauigkeit Accuracy mm	Kugel Ball $\varnothing$ mm	Schaft Shaft $\varnothing$ mm	$L$ mm	$\bar{m}$ kg	Nº
0,01	10	20	95	0,3	1392 101



No. 1392 101

### Referenzpunkt Einstellgerät

### Zero setter



- ▶ Nullpunkt-taster zur Lagebestimmung der Werkstückoberfläche
- ▶ Referenzpunkt setzen der Z Achse
- ▶ Gehäuse  $\varnothing 68\text{mm}$
- ▶ Lieferung einzeln verpackt inkl. Messuhr

- ▶ Zero setter for the determination of workpiece surface point
- ▶ Zero is set on the dial against the Z axis
- ▶ Housing  $\varnothing 68\text{mm}$
- ▶ Delivered in individual packages incl. dial gauge



No. 1393 101

$\Delta z$ mm	$\varnothing$ mm	$L$ mm	$\bar{m}$ kg	Nº
0,01	65	50	0,4	1393 101

# 7

## Wellenmessvorrichtungen

Shaft measuring devices

## Sonderprüfvorrichtungen

Special testing systems

## Messplatten

Surface plates

## Richtplatten

Straightening plates

## Rundlaufprüfgeräte

Concentricity testers

## Spindelstöcke

Headstocks



 **NEW**

Messplatten inkl. Schrankunterbau  
Measuring plates incl. base tool cabinet



7.11

Rundlaufprüfgeräte mit Abrollböcken  
Concentricity testers with balancing stands



7.25

Richtvorrichtung  
Straightening tool



7.25

Abrollböcke schwere Ausführung  
Rolling blocks heavy duty



7.26



+49 (0) 60 21 42 999 00

1

2

3

4

5

6

7

8

9

10

11

12

13

14

15

## Universal Wellenmesszentrum für Ihr spezielles Teilespektrum

## Universal shaft measuring system for your specific workpiece range



Das multifunktionale Messzentrum ist für fast alle rotationsymmetrischen Bauteile geeignet, es ersetzt eine Vielzahl von klassischen Handmessmitteln im Fertigungsbereich. Das Messzentrum wird für Ihr spezielles Teilespektrum angepasst, Werkstücklängen bis 2500mm wurden bereits realisiert.

Sämtliche Messungen von Präzisionsteilen können direkt in der Fertigung durchgeführt werden. Dies ermöglicht eine erhebliche Einsparung von Zeit und Produktionskosten.

### Aufbau:

- ▶ Auf einer stabilen Hartgesteinmessbank mit zentraler T-Nute, ist eine Hochpräzisionsführung mit Verschiebeschleifen montiert. Hierauf sind die Messmodule aufgebaut. Die Werkstückaufnahme erfolgt zwischen Reit- und Spindelstock mit auswechselbaren Spitzen.

### Handling:

- ▶ Von jedem Werker auch ohne spezielle Vorkenntnisse innerhalb kürzester Zeit bedienbar. Alle Messfunktionen und Messergebnisse werden auf einem großen Bildschirm mit Touchscreen-Funktion dargestellt. Sichere reproduzierbare Messergebnisse durch konstante Messkraft.

### Messrechner (optional):

- ▶ Optional kann ein Messrechner (z. B. PRONIMAX) angebunden werden, mit Mess- und Prüfplanungssoftware. Die Ausgabe von Daten und Messprotokollen kann im QStat Format über eine Schnittstelle erfolgen.

### Längenmessung:

- ▶ Kettenmaße, Abstand, Nutbreite, Mittenpunkt, Planlauf

### Durchmessermessung:

- ▶ Ovalität, Achsbildung, Hub, Excenter, Konuswinkel, Rundlauf, Einstiche

### Positionsmessung:

- ▶ Winkelposition, Positionsabstände von Querbohrungen, Länge, Einstichbreite, Durchmesser, Einstichdurchmesser, Steigung an Gewinden, Schnittpunkte

### Optische Messungen:

- ▶ Länge, Einstichbreite, Durchmesser, Einstichdurchmesser, Steigung an Gewinden, Schnittpunkte, Fasen, Flankendurchmesser

### Messprogramme für die Optik:

- ▶ Linie, Winkel, Radius, Kreissegment, Lot, Abstand, Winkelvorgabe, Radiusvorgabe, Theoretischer Kreis, Rundlauf

Zur Angebotserstellung senden Sie uns bitte eine detaillierte Beschreibung Ihrer Messaufgabe mit Zeichnungsunterlagen zu Ihrem Teilespektrum.

This multifunctional measuring system is appropriated for almost all the rotary symmetric components. It replaces a wide range of classic handtools in the production sector. This measuring system can be adapted to your specific workpiece range. It has already been realized for workpiece lengths of up to 2500mm.

All the measurements of precision parts can be carried out right on the shop floor now. This represents a substantial saving in terms of time and of production costs.

### Setup:

- ▶ A high-precision guideway with measuring slide is mounted on a stable granite bench with central T-slot. The measuring modules are built on the indexing slide. Interchangeable points between the headstock and the tailstock realize the workpiece fixture.

### Handling:

- ▶ It is very easy to handle. Any worker shall be able to operate it in less than no time, even if he doesn't have any previous skills or expertise. All of the measurement functions and results are shown on a large touchscreen display. The equipment measures diameter and length using a constant measuring force, reducing operator measurement error.

### Measuring processor (optional):

- ▶ A measuring processor (e.g. PRONIMAX), with measuring and testing schedule software can be used optionally. The output of data and measuring reports can be made in QStat format, through a interface.

### Length measurement:

- ▶ Incremental value, Distance, slot widths, Centre point, Axial run-out

### Diameter measurement:

- ▶ Ovality, Workpiece axis, Throw, eccentricity, Taper angle, Concentricity, Grooves

### Position measurement:

- ▶ Angle position, distances between cross bores, length, slot width, diameter, slot diameter, thread pitch, points of intersection

### Optical measurements:

- ▶ Length, slot width, diameter, slot diameter, thread pitch, points of intersection, chamfers, flank diameter

### Measuring programs for optical system:

- ▶ Line, angle, radius, circle segment, perpendicularity, distance, set angle, set radius, theoretical circle, runout

Please send us a detailed description of your measuring task with technical drawings representing your spectrum of components in order to enable us to prepare a quotation for you.

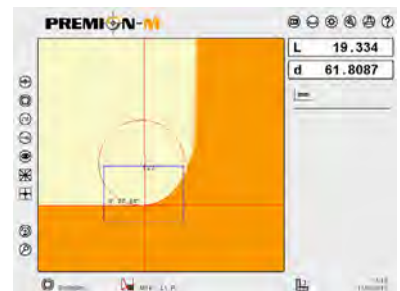
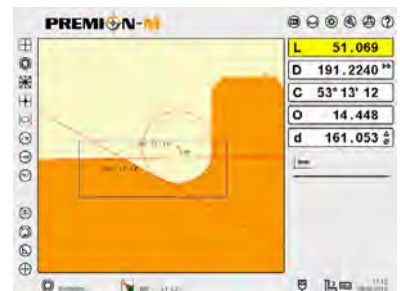

Bildschirm mit Touchscreen-Funktion  
Touchscreen-Display



Beispiele für Werkstücke  
Examples for work pieces

**Messmodule  
für Wellenmesszentrum**

**Measuring modul  
for shaft measuring system**

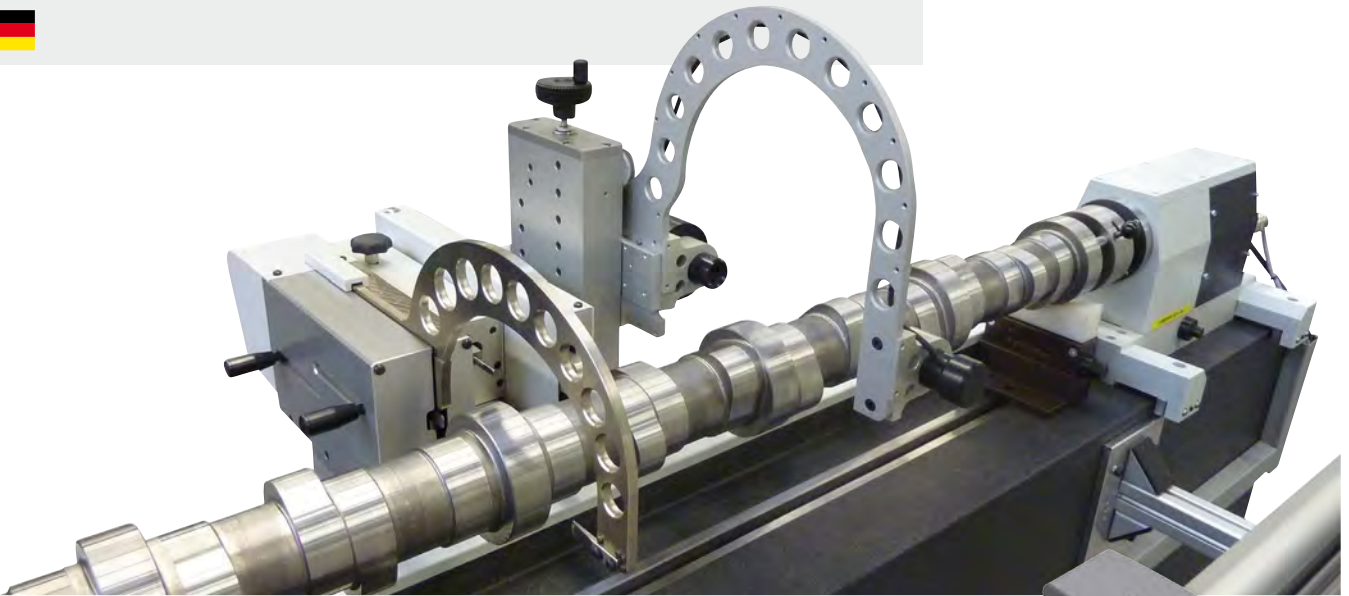

**Spindelstock**  
mit drehbarer Präzisionspinole.

**Headstock**  
with highly precise revolving centre sleeve.

**Reitstock mit starrer Präzisionspinole**  
Zustellweg ca. 45mm. Spannmechanismus wirkt erst mit Kontakt zum Werkstück. Minimaler Kraftaufwand auch bei schweren Werkstücken.

**Tailstock without rotatable centre sleeve**  
Travel of feed approximately 45mm. The clamping mechanism comes into effect only when in contact with the workpiece. Energy waste kept to a minimum, even with heavy workpieces.

**Längen-Positionsmodul L/QP**  
Messung von Längspositionen und Winkelpositionen, ausgestattet mit einem Positions-Zentrierkegel als Antastelement, typische Anwendung: Vermessung von Querbohrungen an einer Welle.

**Longitudinal Position module L/QP**  
Measurement of length and angle positions, featuring a position centering cone, typical application: measurement of cross-holes on a shaft.

**Positionsmodul Lochbild Stirnseite**  
mit eingebautem Maßstab, Antastelemente: Doppel-arretierdorn (Stirnloch) und Scheibenfeder (Nut). Anwendung: manuelle Vermessung von Lochbild (Stirnseite, Radius, Winkel), sowie Abstand Nut und Tiefe Nut an einer Kurbelwelle in Verbindung mit einem im Spindelstock eingebauten Drehgeber.

**Position module hole pattern flange side**  
with integrated gauge, callipers: double arresting bolt (drill holes) and spring-disc (groove). Application: manual measurement of hole pattern (flange side, radius, angle) as well as distance of groove and groove depth on a crankshaft in connection with an encoder that is included in the headstock.

**Positionsmodul Nockenform**  
mit eingebautem Maßstab und motorischer Zustellung, Antastelement Kugelscheibe. Anwendung: Vermessung von Nockenform und Nockenwinkel an Nockenwellen, PC erforderlich!

**Position module cam shape**  
with motor drive and integrated gauge, spherical disc calliper. Application: Measurement of cam shape and cam angle of cam shafts, PC requested!

**Positionsmodul mit Ausrichtprisma und Arretierkegel**  
mit motorischer Zustellung und konstanter Messkraft. Anwendung: Winkelmessung Nut, Hublager an Kurbelwelle in Verbindung mit einem im Spindelstock eingebauten Drehgeber.

**Position module with alignment prism and locking cone**  
with motor drive and constant gauging force. Application: angular measurement of groove, pin bearing of a crankshaft in connection with an encoder that is included in the headstock.

- 1
- 2
- 3
- 4
- 5
- 6
- 7
- 8
- 9
- 10
- 11
- 12
- 13
- 14
- 15

## Messmodule für Wellenmesszentrum



## Measuring modul for shaft measuring system

### Messmodul für Innendurchmesser von 10-140mm

Anwendung: Innendurchmesser und Kombinationsmessungen mit dem Außendurchmesser (Wanddicke). Dynamisch kann der Innendurchmesser ab ca. 10mm Durchmesser gemessen werden (Einfastermessung). Drehgeber, Rollenprismen und Einstellmeister für Innenmessmodul erforderlich.

### Measurement module for bore diameters of 10-140mm

Application: The inside diameter can be measured in combination with the outside diameter (thickness of tube wall). Dynamic measurement of inside diameters from appr. 10mm onwards (single style measurement). Rotation encoder, roller-type V-block and adjustment gauges are required for this module.

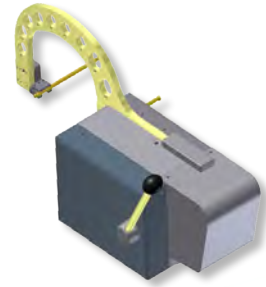

### Durchmessermodul

mit zwei Meßsystemen, Meßbereich 0-125mm oder 0-160 mm. Durchmesserermittlung erfolgt manuell über Messbügel und Läufer.

Anwendung: Durchmesser, Radius, Ovalität, Achsbildung an Werkstückachse (statisch und dynamisch), Hub zur Drehachse, Hub zur Werkstückachse, 1/2 Hub, Winkel am Konus, etc.

### Diameter module

with two measurement systems, measurement range 0-125 mm or range 0-160 mm. Detection of diameter manually by runner and clamp.

Application: diameter, radius, ovality, axle determination static and dynamic, stroke and 1/2 stroke to axle determination, stroke and 1/2 stroke to center, taper angle, etc.

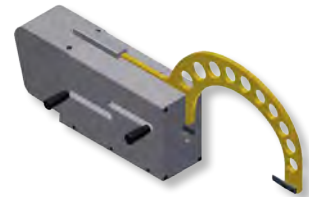

### Durchmessermodul (Kurbelwelle)

mit zwei Meßsystemen, motorische Verstellung, erweiterter Meßbereich 0-220mm.

Durchmesserermittlung erfolgt über Messbügel und Läufer (motorische Zustellung). Speziell hohe Messschneiden für Rundheitsmessung am Hublager von Kurbelwellen.

Anwendung: Durchmesser, Radius, Ovalität, Achsbildung an Werkstückachse, Hub zur Drehachse, Hub zur Werkstückachse, 1/2 Hub, Winkel am Konus, Rundheit am Hauptlager und am Hublager etc.

### Diameter module (crankshaft)

with two measurement systems, motor drive, enhanced measurement range 0-220mm.

Detection of diameter manually by runner and clamp (motor drive). Specially high designed callipers for ovality measurements on pin-bearings of crankshafts. Application: diameter, radius, ovality, axle determination, stroke and stroke radius to axle determination, stroke and stroke radius to center, taper angle, ovality of flange-bearing and pin-bearing, etc.

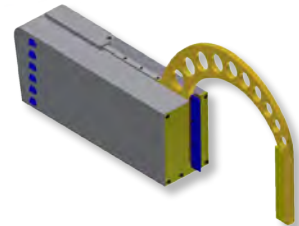

### Optikmodul mit erweitertem Einstellbereich

( $\pm 100$ mm), inklusive motorischer Höhenverstellung. Dieses Modul kann zusätzlich mit dem Fokussierschlitten und der Auflichteinheit ausgestattet werden. Je nach Konfiguration ist der Einstellbereich/Verfahrbereich nach unten eingeschränkt; genaue Werte auf Anfrage.

### Optical module with extended measurement range

( $\pm 100$ mm) including motor drive. This module can be additionally equipped with focusing carriage and incident light source. Depending on configuration, the measuring range in downward direction might be limited, exact values upon request.

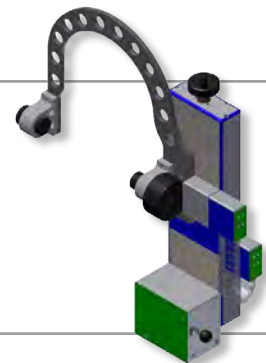

### Rollenprisma

einschließlich Vorablage.

### Roller-type V-block

including preceding tray.



**Mehrstellenmessvorrichtungen  
für rotationssymmetrische Werkstücke**

**Multi-position measuring system  
for rotationally symmetrical workpieces**



Messverfahren taktil oder mit LASER-Modulen.

Measuring method with touch sensors or LASER measuring modules.

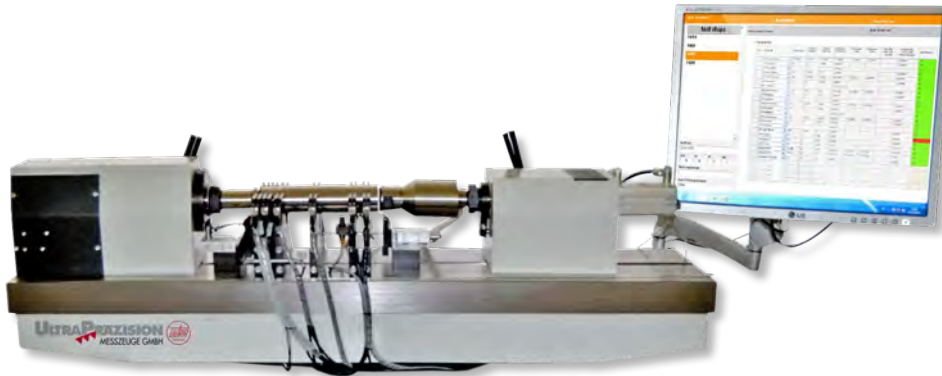

Diese Messvorrichtungen sind modular aufgebaut und wurden speziell für die Serienmessung von rotationssymmetrischen Bauteilen entwickelt. Diese Anlagen werden speziell für Ihr Teilespektrum konzipiert und können sowohl für Klein- als auch für Großbauteile realisiert werden. Die Prüfung Ihrer Werkstücke kann direkt in der Fertigung durchgeführt werden, dies ermöglicht eine erhebliche Einsparung von Zeit und Produktionskosten.

**Aufbau:**

Als Basis dient eine Guss- oder Hartgesteinmessbank mit zentraler T-Nute. Die Messmodule sind in der T-Nute verschiebbar und können auf wechselnde Werkstückparameter angepasst werden. Die Werkstückaufnahme erfolgt zwischen Reit- und Spindelstock (mit Winkeldrehgeber). Die Zentrierspitzen sind auswechselbar.

**Handling:**

Das System ist von jedem Werker auch ohne spezielle Vorkenntnisse innerhalb kürzester Zeit bedienbar. Die Messvorrichtung wird durch das Einlegen einer Meisterwelle voreingestellt. Die Messung aller Merkmale erfolgt in einem Arbeitsschritt, hierfür ist lediglich der Startknopf zu betätigen. Je nach Anforderung dauert die Messung aller Merkmale ca. 5-15 sec.

**Messrechner:**

Alle Merkmale und Messergebnisse werden auf einem großen Bildschirm dargestellt. Auf dem Messrechner können Messablaufprogramme, mit beliebig vielen Merkmalen konfiguriert werden. Optional können die Messergebnisse mit einer Seriennummer in einer SQL Datenbank gespeichert werden und ausgedruckt werden. Die Ausgabe von Daten kann im QStat Format über eine Schnittstelle erfolgen.

**Prüfmerkmale (Beispiele):**

- ▶ Längenmessung
- ▶ Kettenmaße
- ▶ Abstand, Nutbreite, Einstiche
- ▶ Mittelpunkt
- ▶ Planlauf
- ▶ Rundlauf
- ▶ Durchmessermessung
- ▶ Ovalität
- ▶ Achsenbildung

Zur Angebotserstellung senden Sie uns bitte eine detaillierte Beschreibung Ihrer Messaufgabe mit Zeichnungsunterlagen zu Ihrem Teilespektrum.

This measuring system has a modular construction and is especially developed for serial measurements of rotationally symmetrical components. This system is especially conceived for your spectrum of parts and it can be realized for small components as well for large ones. The control of your workpieces can be executed directly in the production area, this allows a considerable saving of time and production costs.

**Construction:**

A cast-iron or granite measuring bench with central T slot serves as a base plate. The measuring modules are designed for sliding in the T slot and they can be adapted to variable workpiece parameters. The workpiece is clamped between the tailstock and the headstock (with rotary encoder). The centering points are interchangeable.

**Handling:**

The system can be operated by any worker, even without any special previous experience, in less than no time. A master shaft shall be inserted to preset the measuring system. All the features shall be measured in one single work step and you must just press the start key for this purpose. Depending on the application requirements the measuring process shall take about 5-15 sec. for all the features.

**Measuring computer:**

All the features and the measuring results are represented on a large display. Measuring sequential programs with as many features as desired can be configured on the measuring computer. Optionally the measuring results can be saved under a series number in a SQL database and also printed. The data output can be performed in QStat format via an interface.

**Control features (examples):**

- ▶ Length measuring
- ▶ Sequential measurements
- ▶ Distance, slot width, grooves
- ▶ Centre point
- ▶ Axial runout
- ▶ Radial runout
- ▶ Diameter measuring
- ▶ Ovality
- ▶ Axis determination

Please send us a detailed description of your measuring task with technical drawings representing your spectrum of components in order to enable us to prepare a quotation for you.



LASER Messmodule  
LASER measuring modules



LASER Messvorrichtung für Turbinenschaufeln  
LASER measuring system for turbine wheels



Mehrstellenmessvorrichtung für Präzisionswellen  
Multi-position measuring system for precision shafts



Bildschirmansicht: Messablaufprogramm  
Screen view: Measuring sequence program

- 1
- 2
- 3
- 4
- 5
- 6
- 7
- 8
- 9
- 10
- 11
- 12
- 13
- 14
- 15



Wir liefern jede Art von Sonderprüfvorrichtungen für Ihren speziellen Anwendungsfall – auf Wunsch auch Konzeption und Konstruktion, gegen Berechnung.

We supply all types of custom made testing system for your special applications – on request also undertake conception and design at a cost.

Zur Angebotserstellung bitten wir um Ihre Anfragen mit Zeichnungsunterlagen.

For the preparation of a quotation, please send us your inquiries with drawings.

Beispiele für bereits realisierte kundenspezifische Sonderlösungen:

Examples of already executed customer-specific special solutions:

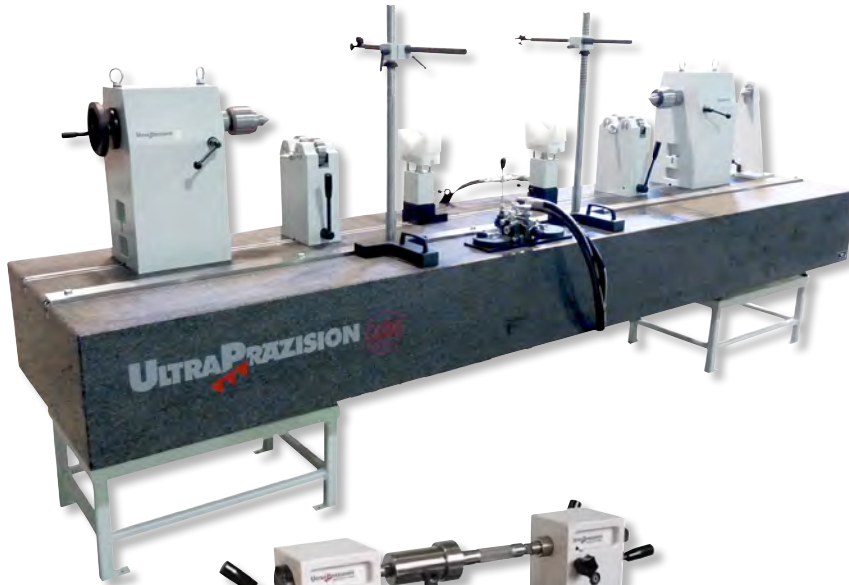

Rundlauf- und Planschlagprüfvorrichtung mit Hartgesteinbasis zur Kontrolle von schweren Rotorwellen zwischen Spitzen, (Spitzenweite 3000mm max. Rundlauffehler <math><3\mu</math>). Optionale zusätzliche Rollenböcke und Werkstückanschlag. Die Vorzentrierung der Werkstücke erfolgt schonend in Kunststoffprismen. Das Heben und Senken des Werkstücks in die Messposition erfolgt hydraulisch.

Testing system for concentricity and axial run out with granite base for checking heavy rotor shafts between centres (Centre distance 3000mm max. error <math><3\mu</math>). Option additional rolling blocks and work piece anvil. Pre-centring in plastic V's to avoid any damage on the work piece surface. The work piece will be put in the measuring position by a hydraulic lifting and kneeling system.



Rundlauf- und Planschlagprüfvorrichtung mit hydraulischem Spanndorn zur Kontrolle von Bremscheiben.

Testing system for concentricity and axial run out with hydraulic clamping shaft for checking break discs.



Sonderanfertigung Reitstöcke mit Spitzenhöhe 450mm

Special designed tailstocks with centre height 450mm



Spindelstock mit motorischem Antrieb, Gegenreitstock mit hydraulischem Pinolenvorschub.

Headstock with motor drive, tailstock with hydraulic sleeve feed.



Schwerlast-Rollenböcke

Rolling blocks for heavy load



**Sonderprüfvorrichtungen**

**Special testing systems**



Wir liefern jede Art von Sonderprüfvorrichtungen für Ihren speziellen Anwendungsfall – auf Wunsch auch Konzeption und Konstruktion, gegen Berechnung.

We supply all types of custom made testing system for your special applications – on request also undertake conception and design at a cost.

Zur Angebotserstellung bitten wir um Ihre Anfragen mit Zeichnungsunterlagen.

For the preparation of a quotation, please send us your inquiries with drawings.

**Beispiele für bereits realisierte kundenspezifische Sonderlösungen:**

**Examples of already executed customer-specific special solutions:**



*Rundlaufprüfvorrichtung mit Hartgesteinbasis zur Kontrolle von schweren Motorwellen zwischen Spitzen, Lastaufnahme durch zusätzliche Rollenböcke.*

*Roundness testing system with granite base for checking heavy engine shafts between centring points, load will be put on additional rolling blocks.*

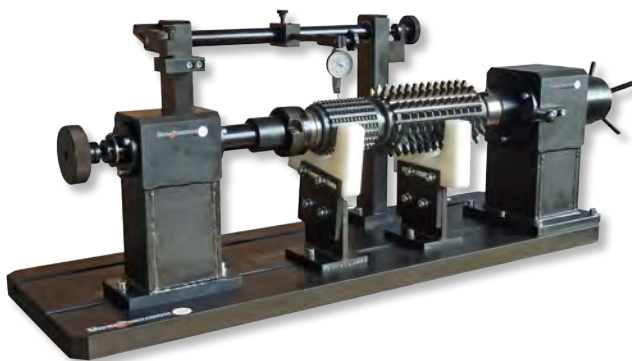

*Spezial Prüfvorrichtung für Wälzfräser*

*Special testing system for hobs*

*Rundlauf- und Planschlagprüfvorrichtung zur Kontrolle von schweren Achswellen auf einem Rollenbock (Rundlauffehler <math><5\mu</math>).*

*Testing system for concentricity and axial run out for checking heavy axis shafts on rolling blocks (max. error <math><5\mu</math>).*

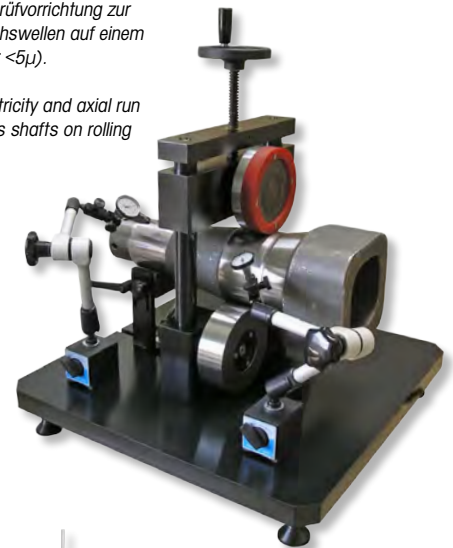

*Rundlauf- und Planschlagprüfvorrichtung mit Hartgesteinbasis zur Kontrolle von kopflastigen Rotorwellen.*

*Testing system for concentricity and axial run out with granite base for checking top-heavy rotor shafts.*



- 1
- 2
- 3
- 4
- 5
- 6
- 7
- 8
- 9
- 10
- 11
- 12
- 13
- 14
- 15



Wir liefern jede Art von Sonderprüfvorrichtungen für Ihren speziellen Anwendungsfall – auf Wunsch auch Konzeption und Konstruktion, gegen Berechnung.

We supply all types of custom made testing system for your special applications – on request also undertake conception and design at a cost.

Zur Angebotserstellung bitten wir um Ihre Anfragen mit Zeichnungsunterlagen.

For the preparation of a quotation, please send us your inquiries with drawings.

Beispiele für bereits realisierte kundenspezifische Sonderlösungen:

Examples of already executed customer-specific special solutions:



Prüfvorrichtung mit Hartsteinbasis zur Kontrolle der Geradheit von Druckmaschinenwellen, schonende Vorzentrierung in Kunststoffprismen. Das Heben und Senken des Werkstücks in die Messposition erfolgt pneumatisch.

Testing system with granite base for checking straightness of printing machine shafts, gentle pre-centring in plastic V's. The work piece will be put in the measuring position by a pneumatic lifting and kneeling system.



Vertikaler Spindelstock mit Präzisionsspannfutter

Vertical headstock with precision chuck



Spindelstock mit motorisch angetriebener Pinole, Gegenreitstock mit hydraulischem Pinolenvorschub.

Headstock with motor driven sleeve, Tailstock with hydraulic sleeve feed.

Spezial Spindelstock mit Präzisionsspannfutter

Special headstock with precision chuck



## Sonderprüfvorrichtungen

## Special testing systems



Wir liefern jede Art von Sonderprüfvorrichtungen für Ihren speziellen Anwendungsfall – auf Wunsch auch Konzeption und Konstruktion, gegen Berechnung.

Zur Angebotserstellung bitten wir um Ihre Anfragen mit Zeichnungsunterlagen.

Beispiele für bereits realisierte kundenspezifische Sonderlösungen:

We supply all types of custom made testing system for your special applications – on request also undertake conception and design at a cost.

For the preparation of a quotation, please send us your inquiries with drawings.

Examples of already executed customer-specific special solutions:

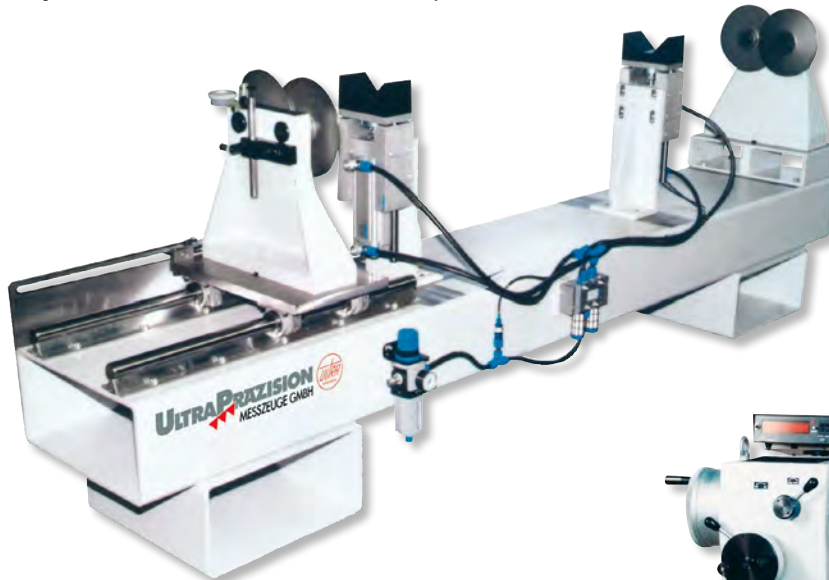

Rundlaufprüfvorrichtung zur Kontrolle der Lagerstellen an Wellen, schonende Vorzentrierung in Kunststoffprismen. Das Heben und Senken des Werkstücks in die Messposition erfolgt pneumatisch.

Roundness testing system for checking bearings on shafts, gentle pre-centring in plastic V's. The work piece will be put in the measuring position by a pneumatic lifting and kneeling system.



Rundlaufprüfvorrichtung mit Hartgesteinbasis zur Kontrolle von Präzisionswellen zwischen Spitzen.

Roundness testing system with granite base for checking high precision shafts between centring points.



Spindelstock mit Planmessvorrichtung auf Hartgesteinbasis.

Headstock with surface measuring system mounted on granite base.



Planmessvorrichtung mit Hartgesteinbasis zum Prüfen der Geradheit und Parallelität von Wellen.

Surface measuring system with granite base for testing straightness and parallelism on shafts.

## ULTRA Natur-Hartgestein

Basisches Tiefengestein aus Schweden und Südafrika verfügt über ein besonders dichtes, homogenes Gefüge und eignet sich deshalb hervorragend für die Herstellung von Messmitteln und Maschinenkomponenten. Diese Hartgesteine sind über Millionen von Jahren auf natürliche Weise gealtert und deshalb völlig frei von inneren Spannungen. Sie sind absolut roststich, säurebeständig, unmagnetisch und elektrisch nichtleitend.

Für ULTRA Hartgestein-Messmittel wird nur ausgesuchtes Material, frei von Fehlern, ohne Einschlüsse und Verwitterungserscheinungen verwendet. Dies garantiert ein Höchstmaß an Formstabilität und Verschleißfestigkeit.

**Folgende Gesteinsarten werden bevorzugt verwendet:**

Gabbro-Impala (Südafrika / South Africa)

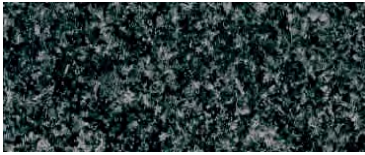

Belfast (Südafrika / South Africa)



Diabas (Schweden / Sweden)



## ULTRA natural granite

Alkaline plutonic rock from Sweden and South Africa provides a particularly dense homogeneous microstructure and is therefore exceptionally suitable for the manufacture of measuring devices and machine components. These rocks have naturally aged over millions of years and are hence completely free from internal stresses. They are absolutely rust-free, acid-resistant, non-magnetic and electrically nonconducting.

Only select material that is free of defect, without inclusions and appearances of weathering is used for the ULTRA granite measuring devices. This guarantees a high degree of shape stability and wear resistance.

**The following stone types are preferentially used:**

**Materialeigenschaften im Vergleich:**

**Material properties in comparison:**

Eigenschaften Properties	Hartgestein Granite	Gusseisen GG25 Cast iron GG25
Längenausdehnungskoeffizient ca. Coefficient of expansion approx.	$5 - 7,5 \times 10^{-6} / K$	$9 - 10 \times 10^{-6} / K$
Wärmeleitfähigkeit Heat conductivity	sehr niedrig Very low	hoch High
Härte Hardness	6 – 7 Mohs-Skala 6 – 7 Mohs' scale	180 – 190 HB
Verschleißfestigkeit Wear resistance	sehr gut Very good	gut Good
Geometrietreue Geometric fidelity	ausgezeichnet Excellent	sehr gut bei korrekter Behandlung Very good with proper handling
Korrosionsbeständigkeit Corrosion resistance	ausgezeichnet Excellent	gut Good
Mechanische Festigkeit Mechanical stability	gut Good	sehr gut Very Good

### Ebenheitstoleranzen nach DIN 876

Die Ebenheit der Messflächen wird mit folgenden Formeln errechnet: (für Wert a, Länge in mm in die Formel einsetzen)

GG	Formel / Formula
000	$(1 + a/1000)\mu$
00	$(2 + a/500)\mu$
0	$(4 + a/250)\mu$

### Flatness tolerances according to DIN 876

The flatness of the measuring surfaces is calculated based on the following formulas: (for value a, indicate length in mm in the formula)

GG	Formel / Formula
1	$(10 + a/100)\mu$
2	$(20 + a/50)\mu$
3	$(40 + a/25)\mu$

### ULTRA Hartgestein-Messplattenservice:

Wir vermessen Ihre Messplatten direkt bei Ihnen Vorort und erstellen einen Kalibrierschein. Falls erforderlich werden die Messflächen gemäß DIN 876 oder nach Ihren ganz persönlichen Anforderungen nachgearbeitet.

#### Ihre Vorteile:

- Sie sparen hohe Verpackungs- und Transportkosten
- Es besteht kein Risiko der Beschädigung auf dem Transportweg
- Die Ausfallzeit Ihrer Messplatte ist minimal

Weitere Informationen erhalten Sie unter:

[www.ultra-germany.com](http://www.ultra-germany.com) > Produkte > Service > Prüfmittelüberwachung

### Sonderprüfvorrichtungen auf Hartgesteinbasis:

Wir liefern jede Art von Maschinenkomponenten sowie Sonderprüfvorrichtungen für Ihren speziellen Anwendungsfall – auf Wunsch auch Konzeption und Konstruktion, gegen Berechnung. Beispiele bereits realisierter Sonderlösungen finden Sie auf Seite 7.6.

### ULTRA granite measuring plates:

We measure your measuring plates directly on your site and issue a calibration certificate. If necessary, the measuring surfaces are re-worked according to DIN 876, or according to your personalised requirements.

#### Your advantages:

- You save the high packaging and transport costs
- No risk of damages in transit
- Minimum downtime for your measuring plate

More information can be had at:

[www.ultra-germany.com](http://www.ultra-germany.com) > Products > Service > Calibration

### Special test units on granite base:

We supply all types of machine components and special test units for your special case of application – if need be conception and design are also undertaken for a fee. You may find examples of already implemented special solutions on page 7.6.

## Mess- und Kontrollplatten aus Naturhartgestein inkl. Schrankunterbau

## Granite surface plates for measuring and inspection incl. base tool cabinet



**NEW**

- ▶ DIN 876/0 (hohe Genauigkeit für die Fertigung)
- ▶ Messfläche diamantgeläpft, korrosionsfest und säurebeständig
- ▶ Außenflächen sauber geschliffen
- ▶ Härte 6–7 nach Mos'scher Skala
- ▶ Inkl. Stahlkugelaufsätze als Auflagepunkte an der Unterseite
- ▶ Lieferung inkl. Werkskalibrierschein und Schrankunterbau

### Schrankunterbau:

- ▶ aus stabilem Vierkantröhren mit Stahlblech verkleidet und lackiert
- ▶ 3 Schubladen rollengelagert (ab 2000mm mit 6 Schubladen)
- ▶ Standfüße höhenverstellbar
- ▶ Baumaße für Arbeitshöhe ca. 900mm

- ▶ DIN 876/0 (high precision for workshop)
- ▶ Diamond-lapped, corrosion-proof and acid-resistant measuring surface
- ▶ Finely ground outer surface
- ▶ Hardness 6–7 on Moh's scale
- ▶ Incl. Steel ball inserts as bearing points at the bottom
- ▶ Delivered with works calibration certificate and base tool cabinet

### Base tool cabinet:

- ▶ Stable square pipe, panelled steel, lacquered
- ▶ 3 roller mounted drawer (from 2000mm with 6 drawer)
- ▶ Height adjustable base
- ▶ Construction dimensions for approx. 900mm working height



No. 1503 1..

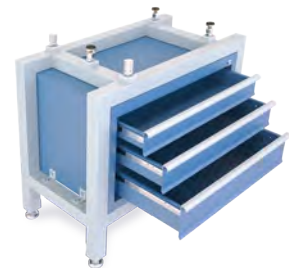

! Plattenstärke für T-Nuten min. 120mm.

! Plate thickness for T-slots min. 120mm.

! Andere Größen und Plattenstärken, höhere Genauigkeiten sowie Sonderausführung nach Zeichnung auf Anfrage.

! Other sizes, plate thicknesses, higher accuracy grades and special versions as per drawings on request.

L mm	h kg	Auflagepunkte Bearing points	μ	0 Nº
600x400x80	125,0	5	7	1503 106
800x600x80	180,0	5	7	1503 108
1000x600x100	240,0	5	8	1503 110
1200x800x120	418,0	5	9	1503 114
1500x1000x160	802,0	5	10	1503 116
2000x1000x200	1295,0	5	12	1503 117

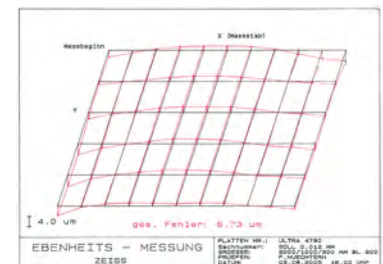

Werkskalibrierschein  
Works calibration certificate

## Pflegemittel für Messmittel

## Cleaner for measuring surfaces



**1508 1.. :**  
für Naturhartgestein und Keramik

**1508 1.. :**  
For granite and ceramic

**1508 2.. :**  
für Naturhartgestein, erhöht die Gleifähigkeit und reduziert den Verschleiß.

**1508 2.. :**  
For granite; enhances smoothness and reduces wear.

Typ Type	Inhalt Volume	Nº
ULTRACLEAN	5 Liter / Litre	1508 101
ULTRACLEAN	1 Liter / Litre	1508 102
ULTRAWAX	400g	1508 202



## Mess- und Kontrollplatten aus Naturhartgestein

## Granite surface plates for measuring and inspection



TOP

- ▶ DIN 876
- ▶ Messfläche diamantgeläppt, korrosionsfest und säurebeständig
- ▶ Außenflächen sauber geschliffen
- ▶ Härte 6–7 nach Mos'scher Skala
- ▶ Inkl. Stahlkugeleinsätze als Auflagepunkte an der Unterseite
- ▶ Lieferung inkl. Werkskalibrierschein, ohne Untergestell

- ▶ DIN 876
- ▶ Diamond-lapped, corrosion-proof and acid-resistant measuring surface
- ▶ Finely ground outer surface
- ▶ Hardness 6–7 on Moh's scale
- ▶ Incl. Steel ball inserts as bearing points at the bottom
- ▶ Delivered with works calibration certificate, without stand

**1500 1.. :**  
Güte 000 höchste Genauigkeit für das Labor

**1500 1.. :**  
Grade 000 highest precision for laboratory

**1501 1.. :**  
Güte 00 hohe Genauigkeit für den Messraum

**1501 1.. :**  
Grade 00 high precision for control room

**1502 1.. :**  
Güte 0 hohe Genauigkeit für die Fertigung

**1502 1.. :**  
Grade 0 high precision for workshop



No. 1502 117

! Plattenstärke für T-Nuten, min. 120mm.

! Plate thickness for T-slots, min. 120mm.

! Andere Größen und Plattenstärken, höhere Genauigkeiten sowie Sonderausführung nach Zeichnung auf Anfrage.

! Other sizes, plate thicknesses, higher accuracy grades and special versions as per drawings on request.

l. mm	kg	Auflagepunkte Bearing points	μ	000 Nº	μ	00 Nº	μ	0 Nº
400x250x50	15,0	3	1,5	1500 102	3	1501 102	6	1502 102
400x400x50	24,0	3	1,5	1500 103	3	1501 103	6	1502 103
600x400x80	55,0	5	1,5	1500 106	3	1501 106	7	1502 106
600x600x80	85,0	5	1,5	1500 107	3	1501 107	7	1502 107
800x600x80	110,0	5	2	1500 108	4	1501 108	7	1502 108
1000x600x100	170,0	5	2	1500 110	4	1501 110	8	1502 110
1000x1000x120	350,0	5	2	1500 112	4	1501 112	8	1502 112
1200x800x120	335,0	5	2,5	1500 114	5	1501 114	9	1502 114
1200x800x160	450,0	5	2,5	1500 115	5	1501 115	9	1502 115
1500x1000x160	700,0	5	2,5	1500 116	5	1501 116	10	1502 116
2000x1000x200	1160,0	5	3	1500 117	6	1501 117	12	1502 117
2000x1000x250	1450,0	5	3	1500 118	6	1501 118	12	1502 118
2000x1500x300	2600,0	5	3	1500 119	6	1501 119	12	1502 119
2000x2000x300	3500,0	6	3	1500 120	6	1501 120	12	1502 120
2500x1500x300	3250,0	7	3,5	1500 121	7	1501 121	14	1502 121
3000x1500x350	4600,0	7	4	1500 122	8	1501 122	16	1502 122
3000x2000x350	6100,0	7	4	1500 123	8	1501 123	16	1502 123

> 3000x2000mm auf Anfrage / on request

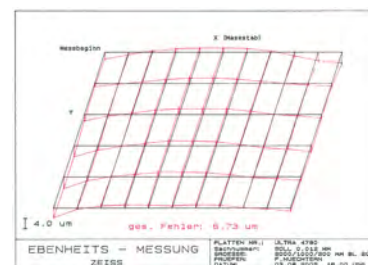

Werkskalibrierschein  
Works calibration certificate



Rundlaufprüfvorrichtung mit Hartgesteinbasis zur Kontrolle von schweren Motorwellen zwischen centring Spitzen, Lastaufnahme durch zusätzliche Rollenböcke.

Roundness testing system with granite base for checking heavy engine shafts between centring points, load will be put on additional rolling blocks.

**T-Nutschienen  
für Messplatten aus Naturhartgestein**

**T-slot bars  
for granite surface plates**



- ▶ DIN 650
- ▶ Spezialstahl, blendfrei mattverchromt
- ▶ fest und dauerhaft mit der Messplatte verbunden
- ▶ Messplattenstärke min. 120mm

- ▶ DIN 650
- ▶ Non-glare satin chrome special steel
- ▶ Firm and stable connection with the measuring plate
- ▶ Plate thickness min. 120mm

**1509 1.. :**  
Spann-T-Nute 14mm H12  
(keine Führungseigenschaften)

**1509 1.. :**  
Clamping T-slot 14mm H12  
(not usable as guide bar)

**1510 1.. :**  
Führungs-T-Nute 10µ/1000mm 14mm H7

**1510 1.. :**  
Guide T-slot 10µ/1000mm 14 mm H7

**1511 1.. :**  
Führungs-T-Nute 4µ/1000mm 14mm H7

**1511 1.. :**  
Guide T-slot 4µ/1000mm 14 mm H7

! überkreuzgeführte T-Nuten sowie andere Nutenmaße auf Anfrage.

! Cross guiding T-slots and other slot sizes on request.

l-l mm	Nº	Nº	Nº
250	1509 101	1510 101	1511 101
400	1509 103	1510 103	1511 103
600	1509 105	1510 105	1511 105
800	1509 108	1510 108	1511 108
1000	1509 109	1510 109	1511 109
1200	1509 114	1510 114	1511 114
1500	1509 116	1510 116	1511 116
2000	1509 118	1510 118	1511 118

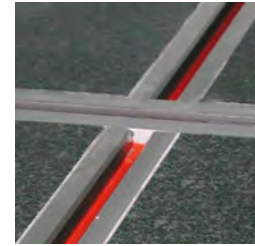

No. 1510 1..

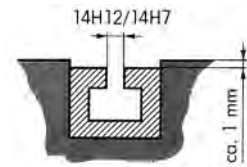
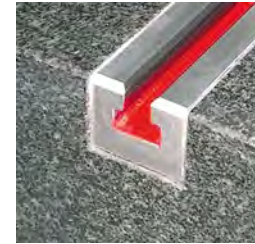

**Gewindeeinsätze für Messmittel  
aus Naturhartgestein**

**Thread inserts  
for granite measuring instruments**



- ▶ rostfreier Stahl
- ▶ Positionsgenauigkeit ± 0,3mm
- ▶ fest und dauerhaft mit der Messplatte verbunden

- ▶ Stainless steel
- ▶ Positioning accuracy ± 0.3mm
- ▶ Firm and stable connection with the measuring plate

! andere Größen, Volleinsätze sowie erhöhte Positionsgenauigkeit auf Anfrage.

! Other sizes, full inserts and enhanced positioning accuracy on request.

Gewinde Threads	Ll mm	Ø mm	Nm max.	Nº
M 3	8	10	3	1507 101
M 4	10	12	3	1507 102
M 5	15	12	5	1507 103
M 6	15	16	10	1507 104
M 8	15	20	20	1507 105
M 10	20	20	40	1507 106
M 12	25	22	50	1507 107
M 16	30	28	150	1507 108
M 20	35	35	200	1507 109

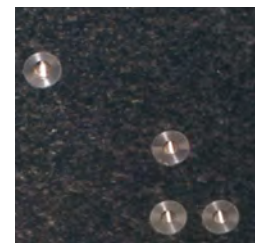

No. 1507 1..

**Tischlagerungen**

**Levelling jacks**



- ▶ zum Ausrichten von Messplatten auf Werktafeln
- ▶ bis Plattengröße 800x600mm
- ▶ aus Stahl mit schwenkbarem Fußgelenk
- ▶ höhenverstellbar mit Gewindespindel M12
- ▶ Lieferung einzeln verpackt

- ▶ For adjusting measuring plates on work tables
- ▶ Plate size up to 800 x 600mm
- ▶ Steel with swivel-mounted foot link
- ▶ Height adjustment with M12 screw
- ▶ Delivered in individual packages

! Messplatten müssen mit Gewindeeinsätzen M12 bestellt werden, es werden min. 3 Füße benötigt.

! Measuring plates should be ordered with M12 thread inserts; at least 3 feet are necessary.

l mm	Fuß / Base Ø mm	W kg	Nº
50 - 70	50	0,35	1524 101



No. 1524 101

## Einzelstützböcke für Messplatten aus Naturhartgestein und Spezialgusseisen

## Supporting feet for granite and cast iron surface plates



- ▶ ab Plattengröße 1000x600mm
- ▶ aus Spezialgusseisen, lackiert
- ▶ höhenverstellbar mit Gewindespindel
- ▶ Lieferung inkl. Lagergarnitur

- ▶ Plate size from 1000x600mm
- ▶ Lacquered special cast iron
- ▶ Height adjustment with screw
- ▶ Delivery incl. levelling screw

h mm	Fuß / Base mm	h kg	Nº
350 – 400	250x250	15,0	1513 101
450 – 500	300x300	25,0	1513 102
550 – 600	250x250	20,0	1513 103
650 – 700	250x250	22,0	1513 104



No. 1513 103

## Untergestelle für Messplatten aus Naturhartgestein

## Stands for granite surface plates



- ▶ ab Plattengröße 600x400mm
- ▶ aus stabilem Vierkantröhr, lackiert
- ▶ Baumaße für Arbeitshöhe von ca. 900mm
- ▶ Lieferung inkl. Lagergarnitur und Kippschutz

- ▶ Plate size from 600x400mm
- ▶ Stable square pipe, lacquered
- ▶ Construction dimensions for approx. 900mm working height
- ▶ Delivery incl. levelling screw and tilt protection

für / for ■ mm	h kg	Nº
600x400	24,0	1512 106
600x600 / 800x600	27,0	1512 108
1000x600 / 1200x800	35,0	1512 109
1000x1000	36,0	1512 112
1500x1000	52,0	1512 116
2000x1000	55,0	1512 118



No. 1512 109

## Schrankunterbau für Messplatten aus Naturhartgestein

## Base tool cabinet for granite surface plates



- ▶ ab Plattengröße 600x400mm
- ▶ aus stabilem Vierkantröhr mit Stahlblech verkleidet und lackiert
- ▶ Schubladen rollengelagert
- ▶ Türen abschließbar
- ▶ Standfüße höhenverstellbar
- ▶ Baumaße für Arbeitshöhe von ca. 900mm
- ▶ Lieferung inkl. Lagergarnitur und Kippschutz

- ▶ Plate size from 600x400mm
- ▶ Stable square pipe, panelled steel, lacquered
- ▶ Roller mounted drawers
- ▶ Lockable doors
- ▶ Height adjustable base
- ▶ Construction dimensions for approx. 900mm working height
- ▶ Delivery incl. levelling screw and tilt protection



No. 1514 116

! Andere Ausführungen auf Anfrage.

! Other versions on request.

für / for ■ mm	h kg	Nº
1 Tür, 1 Schublade / 1 door, 1 drawer		
600x400	44,0	1514 106
600x600 / 800x600	52,0	1514 108
2 Türen, 1 Schublade, 1 Boden / 2 doors, 1 drawer, 1 bottom		
1000x600 / 1200x800	75,0	1514 109
1000x1000	84,0	1514 112
2 Türen, 2 Schubladen / 2 doors, 2 drawers		
1500x1000	98,0	1514 116
3 Türen, 2 Schubladen, 1 Boden / 3 doors, 2 drawers, 1 bottom		
2000x1000	126,0	1514 118



No. 1514 106



No. 1514 109



No. 1514 118



**Läpp- und Kontrollplatten DUPLEX aus Spezialguss**

**Lapping and surface plates, DUPLEX Special cast iron**



- ▶ DIN 876
- ▶ 2 Messfläche Güte 1, geschliffen
- ▶ Lappseite netzförmig quadriert
- ▶ Lieferung im Holzetui

- ▶ DIN 876
- ▶ Two ground measuring surfaces, grade 1
- ▶ Reform lapping surface
- ▶ Delivered in wooden box

ℓ mm	h kg	Nº
360x260x65	28,0	1525 101h
500x300x65	40,0	1525 102h



**Kontroll- und Tuschierplatten aus Spezialguss**

**Surface plates for measuring and inspection Special cast iron**



- ▶ DIN 876
- ▶ stabile Rippenkonstruktion
- ▶ Messflächen fein bearbeitet
- ▶ Lieferung ohne Untergestell

- ▶ DIN 876
- ▶ Stable, ribbed design
- ▶ Finely machined measuring surfaces
- ▶ Delivered without stand



Stabile Rippenkonstruktion  
Stable, ribbed design

<b>1518 1.. :</b> Güte 0 fein geschabt	<b>1518 1.. :</b> Grade 0 fine scraped
<b>1519 1.. :</b> Güte 1 eng geschabt	<b>1519 1.. :</b> Grade 1 narrow scraped
<b>1523 1.. :</b> Güte 3 fein gehobelt	<b>1523 1.. :</b> Grade 3 fine planed
<b>1521 1.. :</b> 1 Paar Stahlhandgriffe	<b>1521 1.. :</b> 1 pair steel handle
<b>1522 1.. :</b> Holzschutzdeckel	<b>1522 1.. :</b> Wooden protective cover

! Andere Größen sowie höhere Genauigkeiten auf Anfrage.

! Other sizes and higher accuracy grades on request.

Größe ℓ mm	h kg	0 Nº	1 Nº	3 Nº	Nº	Nº
200x200x65	7,0	1518 102	1519 102	1523 102	1521 102	1522 102
300x300x85	20,0	1518 103	1519 103	1523 103	1521 103	1522 103
400x400x85	27,0	1518 104	1519 104	1523 104	1521 104	1522 104
500x400x95	37,0	1518 105	1519 105	1523 105	1521 105	1522 105
600x500x100	59,0	1518 106	1519 106	1523 106	1521 106	1522 106
800x500x100	100,0	1518 107	1519 107	1523 107	1521 107	1522 107
1000x 750x150	215,0	1518 108	1519 108	1523 108	1521 108	1522 108
1000x1000x170	290,0	1518 109	1519 109	1523 109	1521 109	1522 109
1200x 800x150	240,0	1518 110	1519 110	1523 110	1521 110	1522 110
1500x1000x180	525,0	1518 111	1519 111	1523 111	-	1522 111
2000x1000x200	810,0	1518 112	1519 112	1523 112	-	1522 112

Tischlagerung und Einzelstützböcke aus Spezialguss  
siehe Katalogseiten 7.13 und 7.14

Levelling jacks and supporting feet made of special cast iron  
see pages 7.13 and 7.14



No. 1524 101



No. 1513 103

**Tuschierpaste**

**Surface paste**



- ▶ zur Oberflächenkontrolle von Werkstücken
- ▶ die Gleichmäßigkeit der Farbschicht zeigt die Qualität der Bearbeitung an
- ▶ Lieferung in Tube oder Dose einzeln verpackt

- ▶ For the surface inspection of work pieces
- ▶ The uniformity of the colour coat indicates the quality of the machining
- ▶ Delivered in individual tube or box

! Leicht entfernbar mit Spezialreiniger Nr. 1532 4.. siehe Seite 7.17  
Hitzebeständige Tuschierpaste auf Anfrage

! Easily removable with special cleaner No. 1532 4.. see page 7.17  
Heat-resistant surface paste on request

Gebinde Packaging	Farbe Colour	Inhalt / Contents g	Nº
Tube / Tube	blau / blue	50	1532 201
Dose / Box	blau / blue	225	1532 203
Tube / Tube	rot / red	70	1532 202
Dose / Box	rot / red	225	1532 204



No. 1532 201



No. 1532 203

## Untergestelle für Messplatten aus Spezialguss

## Stands for cast iron surface plates



- ▶ ab Plattengröße 500x400mm
- ▶ aus stabilem Vierkanrohr, lackiert
- ▶ Baumaße für Arbeitshöhe von ca. 900mm
- ▶ Lieferung einzeln verpackt

- ▶ Plate size from 500x400mm
- ▶ Stable square pipe, lacquered
- ▶ Construction dimensions for approx. 900mm working height
- ▶ Delivered in individual packages

für / for mm	kg	Nº	für / for mm	kg	Nº
500x400	24,0	1531 305	1000x1000	38,0	1531 309
600x500	26,0	1531 306	1200x800	38,0	1531 310
800x500	26,0	1531 307	1500x1000	40,0	1531 311
1000x800	35,0	1531 308	2000x1000	52,0	1531 312



No. 1531 3.

## Anreiß- und Abrichtplatten aus Spezialguss

## Marking-off and surface plates Special cast iron



- ▶ DIN 876
- ▶ stabile Rippenkonstruktion
- ▶ Messfläche fein bearbeitet

- ▶ DIN 876
- ▶ Stable ribbed design
- ▶ Finely machined measuring surface



No. 1529 235

**1529 2.. :**  
Güte 2 fein gefräst

**1529 2.. :**  
Grade 2 fine milled

**1530 1.. :**  
Güte 3 fein gehobelt

**1530 1.. :**  
Grade 3 fine planed

! Zur Aufstellung empfehlen wir unsere Einzelstützböcke Nr. 1513 1...

! Our Supporting feet No. 1513 1... is recommended for mounting.

! Andere Größen, höhere Genauigkeiten sowie Ausführungen mit Anreißlinien oder T-Nuten nach DIN 650 auf Anfrage.

! Other sizes, higher accuracy grades and versions with marking lines or T-slots according to DIN 650 on request.

mm	A mm	Auflagepunkte Bearing points	kg	2 Nº	3 Nº	mm	A mm	Auflagepunkte Bearing points	kg	2 Nº	3 Nº
2000x1500	250	5	2040,0	1529 222	1530 122	3000x2500	300	9	5100,0	1529 229	1530 129
2000x2000	250	5	2530,0	1529 223	1530 123	4000x1500	250	11	4000,0	1529 230	1530 130
2500x1000	250	6	1730,0	1529 224	1530 124	4000x2000	300	11	5300,0	1529 231	1530 131
2500x1500	250	8	2470,0	1529 225	1530 125	4000x2500	300	12	6850,0	1529 232	1530 132
2500x2000	250	8	3050,0	1529 226	1530 126	4500x2000	300	11	5850,0	1529 233	1530 133
3000x1500	250	8	2980,0	1529 227	1530 127	5000x1500	300	14	5330,0	1529 234	1530 134
3000x2000	300	8	3940,0	1529 228	1530 128	5000x2000	300	14	6540,0	1529 235	1530 135



## Anreißfarben

## Marking paints



- ▶ zum Anreiß- und Markieren von Werkstücken
- ▶ schnelltrocknend ohne abzublättern
- ▶ Verarbeitung mit Pinsel oder als Spray (FCFKW frei)
- ▶ Lieferung Spraydose oder Flasche einzeln verpackt

- ▶ For the scribing and marking of work pieces
- ▶ Quick dry without peeling off
- ▶ Working with brush or as spray (CFC-free)
- ▶ Delivered in individually packed spray cans or bottles

! Leicht entfernbar mit Lösemittelspray Nr. 1532 301 siehe Seite 7.19  
Farbe weiß auf Anfrage.

! Easily removable with solvent spray No. 1532 301 see page 7.19  
White colour on request.



No. 1532 100



No. 1532 101



No. 1532 103

Gebinde Packaging	Farbe Colour	Inhalt / Contents ml	Nº
Streichstift / Colour pencil	blau / blue	-	1532 100
Spray / Spray	blau / blue	300	1532 101
Flasche / Bottle	blau / blue	500	1532 103
Spray / Spray	rot / red	300	1532 102
Flasche / Bottle	rot / red	500	1532 104

**Richtplatten  
aus Spezialguss**

**Straightening plates  
Special cast iron**



- ▶ Werksnorm
- ▶ Oberfläche und 4 Seiten fein gehobelt oder fein gefräst

- ▶ Works standard
- ▶ Surface and 4 sides fine planed or fine milled

**1535 1.. :**  
massive Ausführung

**1535 1.. :**  
Solid design

**1536 1.. :**  
Rippenkonstruktion

**1536 1.. :**  
Ribbed design

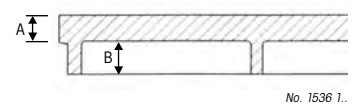

**!** Andere Größen sowie Ausführungen mit Löchern, Bohrungen oder T-Nuten nach DIN 650 auf Anfrage.

**!** Other sizes and versions with holes or T-slots according to DIN 650 on request

■ mm	A mm	⚖ kg	Nº
200x200	40	12,0	<b>1535 101</b>
300x300	50	34,0	<b>1535 102</b>
400x400	50	60,0	<b>1535 103</b>
500x500	60	112,0	<b>1535 104</b>
600x600	70	189,0	<b>1535 105</b>
700x700	80	294,0	<b>1535 106</b>
800x800	100	480,0	<b>1535 107</b>
1000x800	100	600,0	<b>1535 108</b>
1000x1000	110	825,0	<b>1535 109</b>
1200x800	90	648,0	<b>1535 110</b>
1200x1000	110	990,0	<b>1535 111</b>
1500x1000	120	1350,0	<b>1535 112</b>
2000x1000	120	1800,0	<b>1535 113</b>

■ mm	A mm	B mm	⚖ kg	Nº
-	-	-	-	-
-	-	-	-	-
400x400	30	50	42,0	<b>1536 103</b>
500x500	40	40	84,0	<b>1536 104</b>
600x600	40	40	120,0	<b>1536 105</b>
700x700	40	40	165,0	<b>1536 106</b>
800x800	40	40	216,0	<b>1536 107</b>
1000x800	40	60	270,0	<b>1536 108</b>
1000x1000	40	60	340,0	<b>1536 109</b>
1200x800	60	60	470,0	<b>1536 110</b>
1200x1000	60	60	590,0	<b>1536 111</b>
1500x1000	60	60	735,0	<b>1536 112</b>
2000x1000	60	60	980,0	<b>1536 113</b>

**Untergestelle für Richtplatten**

**Stands for straightening plates**



- ▶ ab Plattengröße 400x400mm
- ▶ aus stabilem Profilstahl, lackiert
- ▶ Baumaße für Arbeitshöhe von ca. 900mm
- ▶ Lieferung einzeln verpackt

- ▶ Plate size from 400x400mm
- ▶ Stable, lacquered steel section
- ▶ Construction dimensions for approx. 900mm working height
- ▶ Delivered in individual packages



für / for ■ mm	⚖ kg	Nº
400x400	24,0	<b>1537 103</b>
500x500	26,0	<b>1537 104</b>
600x600	27,0	<b>1537 105</b>
700x700	30,0	<b>1537 106</b>
800x800	32,0	<b>1537 107</b>
1000x800	35,0	<b>1537 108</b>

für / for L mm	⚖ kg	Nº
1000x1000	38,0	<b>1537 109</b>
1200x800	38,0	<b>1537 110</b>
1200x1000	38,0	<b>1537 111</b>
1500x1000	40,0	<b>1537 112</b>
2000x1000	52,0	<b>1537 113</b>

**Spezialreiniger für Tuschierpasten**

**Special cleaner for surface pastes**



- ▶ zur allgemein Reinigung von Werkstücken, löst Wachs, Fett und Schmutz
- ▶ besonders zum Entfernen von Tuschierpaste geeignet
- ▶ Lieferung in Flasche oder Kanister einzeln verpackt

- ▶ For the general cleaning of work pieces; dissolves wax, fat and dirt
- ▶ Especially suitable for the removal of surface pastes
- ▶ Delivered in individually packed bottle or canister

**!** Tuschierpaste siehe Seite 7.15

**!** Surface paste see page 7.15

Gebinde Packaging	Inhalt / Contents l	Nº
Flasche / Bottle	1	<b>1532 401</b>
Kanister / Canister	10	<b>1532 402</b>
Kanister / Canister	25	<b>1532 403</b>



## Rundlaufprüfgerät UNITEST mit Messstativen

## Concentricity testers UNITEST with measuring stands



- ▶ Werksnorm
- ▶ zur Rundlauf- und Planschlagprüfung
- ▶ Rundlaufgenauigkeit 0,002mm
- ▶ Präzisionsrollen Ø30mm mit Einstich aus gehärtetem Stahl
- ▶ Antrieb durch seitliches Handrad
- ▶ Gehäuse aus eloxiertem Aluminium
- ▶ Wellen zur Stativführung aus hartverchromtem Stahl
- ▶ Niederhalter für Werkstücke federbelastet
- ▶ Werkstückanschlag, längen- und höhenverstellbar
- ▶ 2 Stativ für Fühlhebelmessgeräte, Aufnahmebohrung Ø 8mm
- ▶ Lieferung einzeln verpackt ohne Fühlhebelmessgeräte

- ▶ Works standard
- ▶ For checking concentricity and wobble
- ▶ Concentricity accuracy 0.002mm
- ▶ Precision rollers Ø30mm with groove made of hardened tool steel
- ▶ Drive with hand wheel on side face
- ▶ Aluminium housing, anodized
- ▶ Hard chromed steel bars for measuring stand sliding
- ▶ Spring loaded work piece clamping system
- ▶ Work piece anvil adjustable in length and height
- ▶ 2 measuring stands for dial test indicators, mounting hole Ø 8mm
- ▶ Delivered in individual packages without dial test indicators



No. 1559 501 / 1559 502



L mm	Werkstück / Work piece Ø mm	M kg	Nº
350 x 118 x 140	1,5 – 50	8,5	1559 501
350 x 118 x 140	10 – 100	12,0	1559 502



Antrieb durch seitliches Handrad  
Drive with hand wheel on side face



Niederhalter für kleine Durchmesser  
Spring loaded workpiece clamping system for small diameters



Niederhalter für große Durchmesser  
Spring loaded workpiece clamping system for large diameters



Schiebeelement für zusätzliches Messstativ  
Sliding element for additional measuring stand

## Rundlaufprüfgerät UNITEST mit Messstativen und zusätzlichem, verschiebbarem Rollenbock

## Concentricity testers UNITEST with measuring stands and additional, moveable rolling blocks



- ▶ Werksnorm
- ▶ zur Rundlauf- und Planschlagprüfung
- ▶ Rundlaufgenauigkeit 0,002mm
- ▶ Präzisionsrollen Ø30mm mit Einstich aus gehärtetem Stahl
- ▶ Antrieb durch seitliches Handrad
- ▶ Gehäuse aus eloxiertem Aluminium
- ▶ Wellen zur Stativführung aus hartverchromtem Stahl
- ▶ Niederhalter für Werkstücke federbelastet
- ▶ Werkstückanschlag, längen- und höhenverstellbar
- ▶ 2 Stativ für Fühlhebelmessgeräte, Aufnahmebohrung Ø 8mm
- ▶ Lieferung einzeln verpackt ohne Fühlhebelmessgeräte

- ▶ Works standard
- ▶ For checking concentricity and wobble
- ▶ Concentricity accuracy 0.002mm
- ▶ Precision rollers Ø30mm with groove made of hardened tool steel
- ▶ Drive with hand wheel on side face
- ▶ Aluminium housing, anodized
- ▶ Hard chromed steel bars for measuring stand sliding
- ▶ Spring loaded work piece clamping system
- ▶ Work piece anvil adjustable in length and height
- ▶ 2 measuring stands for dial test indicators, mounting hole Ø 8mm
- ▶ Delivered in individual packages without dial test indicators



No. 1559 511 / 1559 512

Mit zusätzlichem Rollenbock  
With additional rolling blocks



L mm	Werkstück / Work piece Ø mm	M kg	Nº
350 x 118 x 140	1,5 – 50	8,8	1559 511
350 x 118 x 140	10 – 100	12,3	1559 512

**Rundlaufprüfergerät  
für vertikale und horizontale Anwendung**

**Concentricity testers  
for vertical and horizontal application**



**Gehärtet  
Hardened**

- ▶ Werksnorm
- ▶ Messfläche fein geschliffen
- ▶ linke Seite (Standfuß) mit fester Pinole
- ▶ rechter Reitstock mit beweglicher Pinole
- ▶ Grundplatte mit T-Nute
- ▶ Lieferung einzeln verpackt

- ▶ Works standard
- ▶ Finely ground measuring faces
- ▶ Left side (base) with fixed centre sleeve
- ▶ Right tailstock with movable centre sleeve
- ▶ Base plate with T-slot
- ▶ Delivered in individual packages

**Anwendung:**

- ▶ Rundlauf- und Planschlagprüfung
- ▶ Als Basis zum Messen von Durchmessern, Absätzen, Längen und Abständen

**Application:**

- ▶ Checking concentricity and wobble
- ▶ Usable as base to measure, diameters, steps, length and distance.

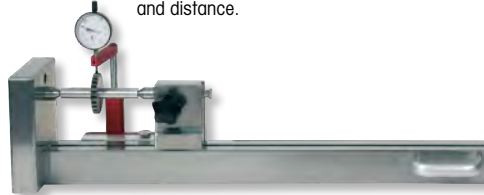
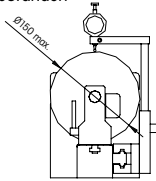

**1567 201 :**  
Ausführung ohne Messstativ

**1567 201 :**  
Model without measuring stand

**1567 202 :**  
Ausführung mit Messstativ,  
verschiebbar auf separater Führungsschiene

**1567 202 :**  
Model with measuring stand,  
moveable on a separate sliding rail

∅ mm	L mm	T-Nute / T-slot mm	kg	Nº
75	550	10H7	36,0	<b>1567 201</b>
75	550	10H7	35,5	<b>1567 202</b>

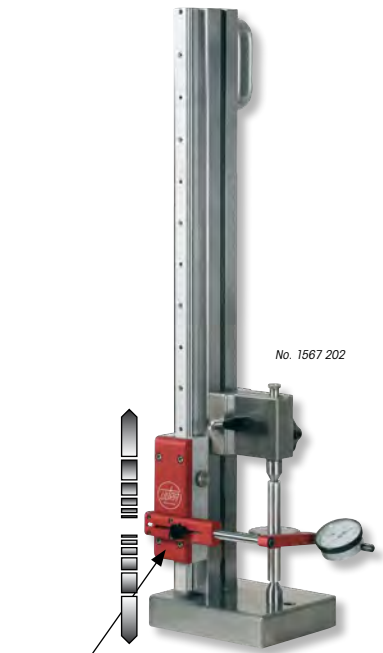

No. 1567 202

Stativ verschiebbar auf  
separater Führungsschiene  
Stand moveable on a  
separate sliding rail

**Kegelprüfergeräte  
nach Sinusprinzip**

**Taper testing instruments  
based on the sine principle**



- ▶ DIN 876
- ▶ Messflächen Güte 1, feingeschliffen
- ▶ linker Reitstock mit fester Pinole
- ▶ rechter Reitstock mit beweglicher Pinole
- ▶ Sinustisch mit T-Nute auf beweglichem Schlitzen mit hochgenauer Kugelführung
- ▶ Stativ mit Feineinstellung
- ▶ Messuhraufnahme Ø 8mm
- ▶ Lieferung inkl. Sinustabelle, ohne Messuhr

- ▶ DIN 876
- ▶ Finely ground measuring faces, grade 1
- ▶ Left tailstock with fixed centre sleeve
- ▶ Right tailstock with movable centre sleeve
- ▶ Sine table with T-slot on movable slide with high-precision ball guide
- ▶ Measuring stand with fine adjustment
- ▶ Dial mounting hole Ø 8mm
- ▶ Delivered incl. sine table, without dial gauge

**1566 101 :**  
Reitstöcke ohne Prismenaufsatz

**1566 101 :**  
Tailstocks without V blocks

**1566 102 :**  
Reitstöcke mit Prismenaufsatz

**1566 102 :**  
Tailstocks with V blocks

**I** Passendes Zubehör siehe Nr. 1562 ... , Nr. 1563 ... und Nr. 1564 ...

**I** For suitable accessories, see No. 1562 ... , No. 1563 ... and No. 1564...

∅ mm	L mm	L mm	Tischweg Table path mm	T-Nute T-slot mm	kg	Nº
50	200	330x70	150	10H7	26,5	<b>1566 101</b>
75	200	330x70	150	10H7	27,5	<b>1566 102</b>



No. 1566 101

**Lösemittelspray für Anreißfarben**

**Solvent spray for marking colours**



- ▶ zur allgemein Reinigung von Werkstücken
- ▶ besonders zum Entfernen von Anreißfarbe geeignet
- ▶ Lieferung in Spraydose einzeln verpackt

- ▶ For the general cleaning of work pieces
- ▶ Especially suitable for the removal of marking colours
- ▶ Delivered in individually packed spray cans

**I** Anreißfarbe siehe Seite 7.16

**I** Marking colours see page 7.16

Gebinde Packaging	Inhalt / Contents ml	Nº
Spray / Spray	300	<b>1532 301</b>



No. 1532 301

## Rundlaufprüfgeräte aus Spezialguss

## Concentricity testers Special cast iron



- ▶ DIN 876
- ▶ Messfläche Güte 1, fein geschliffen
- ▶ linker Reitstock mit fester Pinole
- ▶ rechter Reitstock mit beweglicher Pinole
- ▶ Grundplatte mit 2 T-Nuten
- ▶ Stativ mit Feineinstellung, Messuhraufnahme Ø 8mm
- ▶ Lieferung einzeln verpackt

- ▶ DIN 876
- ▶ Finely ground measuring face, grade 1
- ▶ Left tailstock with fixed centre sleeve
- ▶ Right tailstock with movable centre sleeve
- ▶ Base plate with 2 T-slots
- ▶ Stand with fine adjustment, dial mounting hole Ø 8mm
- ▶ Delivered in individual packages

**1560 1.. :**  
Reitstöcke ohne Prismenaufsatz

**1560 1.. :**  
Tailstocks without V blocks

**1561 1.. :**  
Reitstöcke mit Prismenaufsatz

**1561 1.. :**  
Tailstocks with V blocks

**!** Reitstockpaare ohne Grundplatte auf Anfrage.  
Passendes Zubehör siehe Seite 7.21 – 7.22

**!** Tailstock pair without base plate on request.  
Suitable accessories see page 7.21 – 7.22

l mm	l mm	L mm	T-Nute / T-slot mm	kg	Nº
ohne Prismenaufsatz / Without V blocks					
50	200	350x110	10H7	8,0	1560 101
50	350	500x110	10H7	11,0	1560 103
100	450	700x180	12H7	35,0	1560 105
150	450	700x180	12H7	38,0	1560 106
mit Prismenaufsatz / With V blocks					
75	200	350x110	10H7	9,0	1561 102
75	350	500x110	10H7	12,0	1561 104
100	450	700x180	12H7	36,0	1561 105
150	450	700x180	12H7	39,0	1561 106

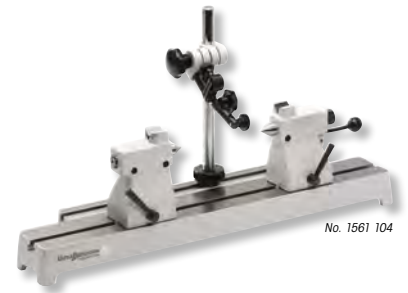

No. 1561 104



No. 1560 1..



No. 1561 1..

## Messbänke aus Spezialguss

## Test benches Special cast iron



- ▶ DIN 876
- ▶ zum individuellen Aufbau von Rundlaufprüfvorrichtungen
- ▶ Messfläche Güte 1, fein geschliffen
- ▶ Grundplatte mit 2 T-Nuten
- ▶ Lieferung einzeln verpackt

- ▶ DIN 876
- ▶ For individual mounting of concentricity test units
- ▶ Finely ground measuring face, grade 1
- ▶ Base plate with 2 T-slots
- ▶ Delivered in individual packages

l mm	T-Nute / T-slot mm	kg	Nº
200x110	10H7	3,5	1560 501
350x110	10H7	5,5	1560 502
500x110	10H7	8,5	1560 503
700x180	12H7	26,0	1560 504



No. 1560 502

## Zentrierspitzen

## Centre points



- ▶ aus gehärtetem Spezialstahl
- ▶ Lieferung paarweise verpackt

- ▶ Hardened special steel
- ▶ Delivered in a package (pair)

**1564 1.. :**  
60° Standard

**1564 1.. :**  
60° Standard

**1564 2.. :**  
Zentrierbohrung DIN 332-A 1,6 x 3,8mm

**1564 2.. :**  
Centre bore DIN 332-A 1.6 x 3.8mm

**1564 3.. :**  
60° Hartmetallbestückt

**1564 3.. :**  
60° Tungsten carbide-tipped

für / for l mm	Schaft / Shaft Ø mm	kg	Nº	Nº	Nº
50/75	16	0,4	1564 101	1564 201	1564 301
100/150	22	0,6	1564 102	1564 202	1564 302



No. 1564 101



No. 1564 201

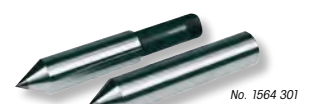

No. 1564 301

**Reitstock mit drehbarer Spannzangenaufnahme aus Spezialguss**

**Tailstock with rotary collet holder Special cast iron**



- ▶ Standfläche fein geschliffen
- ▶ Rundlaufgenauigkeit 0,005mm
- ▶ Lieferung einzeln verpackt ohne Spannzangen

- ▶ Finely ground base
- ▶ Concentricity 0.005 mm
- ▶ Delivered in individual packages without collets

! Spannzangen müssen zusätzlich bestellt werden.

! Collets should be additionally ordered.

∩ mm	Nutsteine / Slot mm	für Spannzange Typ for Collet Type	⚖ kg	Nº
75	10h6	F14	3,5	1562 502
100	12h6	F14	9,0	1562 103
100	12h6	F20	9,0	1562 503



**Spannzangen für drehbare Spannzangenaufnahme**

**Collets for rotary collet holder**



- ▶ Stufung 0,5mm
- ▶ Spannbereich einer Spannzange ± 0,25mm
- ▶ Lieferung einzeln verpackt

- ▶ Step 0.5 mm
- ▶ Clamping range of one collet ± 0.25mm
- ▶ Delivered in individual packages

! Bei Bestellung bitte gewünschten Ø angeben.

! Please specify Ø in order.

! Spannzangen mit erhöhter Genauigkeit auf Anfrage.

! Collets with higher accuracy on request.

Typ Type	Genauigkeit / Accuracy mm	Ø mm	⌒ mm	Nº
F14	0,015	3 – 10	0,5	1562 202
F20	0,02	4 – 16	0,5	1562 203



**Prismeneinsätze**

**V inserts**



- ▶ zur Montage in Reitstöcke anstatt Zentrierspitzen
- ▶ Lieferung paarweise verpackt

- ▶ For mounting on tailstocks instead of centre points
- ▶ Delivered in a package (pair)

∩ mm	Prüfling / Test piece Ø mm	Schaft / Shaft Ø mm	⚖ kg	Nº
50/75	3 – 15	16	0,4	1563 101
100/150	8 – 45	22	1,0	1563 102

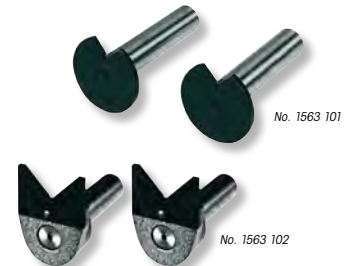

**Prismenböcke aus Spezialguss**

**V blocks, special cast iron**



- ▶ Standfläche feingeschliffen
- ▶ Prismen aus Spezialstahl gehärtet
- ▶ Lieferung paarweise verpackt

- ▶ Finely ground base
- ▶ Hardened special steel V blocks
- ▶ Delivered in a package (pair)

1563 2.. :

Prismenböcke Standard

1563 2.. :

V blocks standard

1563 4.. :

Prismenböcke höhenverstellbar, Verstellbereich 21mm zum Ausgleich unterschiedlicher Werkstück Ø.

1563 4.. :

V blocks height adjustable, range 21mm for adjusting different workpiece Ø.

∩ mm	Prüfling Test piece Ø mm	Nutsteine Slot mm	⚖ kg	Nº	⚖ kg	Nº
50/75	5 – 25	10h6	1,0	1563 201	1,8	1563 401
100	8 – 50	12h6	4,0	1563 202	5,7	1563 402



## Abrollböcke aus Spezialguss

## Rolling blocks, special cast iron



**Gehärtet  
Hardened**

- ▶ Standfläche fein geschliffen
- ▶ Rollen aus gehärtetem Stahl
- ▶ Lieferung paarweise verpackt

- ▶ Finely ground base
- ▶ Hardened steel rollers
- ▶ Delivered in a package (pair)

### 1563 3.. :

Abrollböcke Standard

### 1563 3.. :

Rolling blocks standard

### 1563 5.. :

Abrollböcke höhenverstellbar, Verstellbereich 21mm zum Ausgleich unterschiedlicher Werkstück Ø.

### 1563 5.. :

Rolling blocks height adjustable, range 21mm for adjusting different workpiece Ø.

l mm	Prüfling Test piece Ø mm	Nutsteine Slot mm	kg	kg	Nº	kg	Nº
50/75	2 – 40	10h6	150	1,0	1563 301	1,8	1563 501
100	2 – 60	12h6	150	4,0	1563 302	5,7	1563 502



No. 1563 301



No. 1563 501

## Messtaster

## Measuring probe



- ▶ für Serienprüfung
- ▶ Werkstücke können von oben ins Gerät eingelegt werden
- ▶ Messhrafnahme Ø 8mm
- ▶ Lieferung einzeln verpackt, ohne Messuhr

- ▶ For series inspection
- ▶ Workpieces can be inserted into the device from the top
- ▶ Dial mounting hole Ø 8mm
- ▶ Delivered in individual packages, without dial gauges

l mm	Messweg / Measuring span mm	Nutstein / Slot mm	kg	Nº
50/75	10	10	0,8	1565 101



No. 1565 101

## Messtative

## Measuring stands



- ▶ Messhrafnahme Ø8mm
- ▶ Lieferung einzeln verpackt

- ▶ Dial mounting hole Ø 8mm
- ▶ Delivered in individual packages

### 1565 2.. :

Querarm verstellbar mit Feineinstellung

### 1565 2.. :

Adjustable arm with fine adjustment

### 1565 5.. :

Querarm starr

### 1565 5.. :

Rigid arm

l mm	Ø mm	Nutstein / Slot mm	kg	Nº
150	16	10	0,9	1565 201
160	18	10	0,9	1565 501
200	22	12	1,5	1565 202
400	22	12	2,0	1565 203



No. 1565 201



No. 1565 501



## Rundlaufprüfgeräte mit Hartgestein-Messbank

## Concentricity testers with granite bench



- ▶ DIN 876
- ▶ Messflächen Güte 1, feingeschliffen
- ▶ linker Reitstock mit fester Pinole
- ▶ rechter Reitstock mit beweglicher Pinole, arretierbar
- ▶ Messstativ mit Feineinstellung
- ▶ Messuhraufnahme Ø 8mm
- ▶ Lieferung einzeln verpackt

- ▶ DIN 876
- ▶ Finely ground measuring faces, grade 1
- ▶ Left tailstock with fixed centre sleeve
- ▶ Right tailstock with movable and lockable centre sleeve
- ▶ Measuring stand with fine adjustment
- ▶ Dial mounting hole Ø 8mm
- ▶ Delivered in individual packages



**1554 1.. :**  
Reitstöcke ohne Prismenaufsatz

**1554 1.. :**  
Tailstocks without V blocks

**1555 1.. :**  
Reitstöcke mit Prismenaufsatz, gehärtet

**1555 1.. :**  
Tailstocks with V blocks, hardened

∏ mm	∏ mm	∏ mm	T-Nute / T-slot mm	kg	Nº	Nº
200	650	1100x200x140	14H7	110,0	1554 101	1555 101
200	850	1300x200x140	14H7	125,0	1554 102	1555 102
200	1150	1600x200x140	14H7	155,0	1554 103	1555 103

## Reitstockpaare aus Spezialguss

## Tailstock pairs Special cast iron



- ▶ DIN 876
- ▶ Achsgenauigkeit Güte 1 / ±0,008mm
- ▶ Standflächen feingeschliffen
- ▶ mit oder ohne Prismenaufsatz 90° aus gehärtetem Stahl
- ▶ linker Reitstock mit fester Pinole,
- ▶ rechter Reitstock mit beweglicher Pinole, arretierbar
- ▶ Verstellung mit Handhebel oder Handrad
- ▶ Excenterspannung für Klemmung in T-Nuten
- ▶ T-Nutensteine 14mm h6
- ▶ Lieferung paarweise inkl. Zentrierspitzen

- ▶ DIN 876
- ▶ Centre accuracy grade 1 / ±0.008mm
- ▶ Finely ground base
- ▶ With or without hardened steel V blocks 90°
- ▶ Left tailstock with fixed centre sleeve
- ▶ Right tailstock with movable and lockable centre sleeve
- ▶ Adjustment with hand lever or hand wheel
- ▶ Excentric clamping for T nuts
- ▶ T-slots 14mm h6
- ▶ Delivered in pairs incl. centre points



**1551 1.. / 1553 1.. :**  
Güte 1, Handhebel

**1551 1.. / 1553 1.. :**  
Grade 1, hand lever

**1551 5.. / 1553 5.. :**  
Güte 1, Handrad

**1551 5.. / 1553 5.. :**  
Grade 1, hand wheel

! Größere Spitzenhöhe, Güte 0 / ±0,004mm auf Anfrage.

! Larger centre heights, grade 0 / ±0.004mm on request.

∏ mm	Aufnahme Shaft MK	Hub Range mm	Paar Pair ∏ mm	kg	Nº	Nº
Reitstockpaar ohne Prismenaufsatz / Tailstock pair without V blocks						
100	2	15	290	10,0	1551 101	1551 501
150	2	20	360	25,0	1551 102	1551 502
200	2	20	390	30,0	1551 103	1551 503
250	3	30	490	55,0	1551 104	1551 504
300	3	30	570	80,0	1551 105	1551 505
Reitstockpaar mit gehärtetem Prismenaufsatz 90° / Tailstock pair with hardened V blocks 90°						
100	2	15	290	12,0	1553 101	1553 501
150	2	20	360	28,0	1553 102	1553 502
200	2	20	390	35,0	1553 103	1553 503
250	3	30	490	60,0	1553 104	1553 504
300	3	30	570	85,0	1553 105	1553 505



Rundlaufprüfgerät mit Hartgesteinbasis, Unterschrank Sonderanfertigung  
Concentricity testers with granite base, Tool cabinet special design

## Messbänke für Rundlaufprüfgeräte aus Naturhartgestein

## Test benches for concentricity testers Natural granite



TOP

Länge  
Length ≤4000mm

- ▶ DIN 876/1
- ▶ Messfläche diamantgeläppt, korrosionsfest und säurebeständig
- ▶ Außenflächen sauber geschliffen
- ▶ Härte 6-7 nach Mos'scher Skala
- ▶ Stahlkugeleinsätze als Auflagepunkte an der Unterseite
- ▶ Führungs-T-Nute 8µ/1000mm 14mm H7
- ▶ Lieferung inkl. Werkskalibrierschein

- ▶ DIN 876/1
- ▶ Diamond-lapped, non-corrosive and acid resistant measuring surface
- ▶ Finely ground outer surfaces
- ▶ Hardness 6-7 on Moh's scale
- ▶ Steel ball inserts as bearing points at the bottom
- ▶ T-slot guide 8µ/1000mm 14mm H7
- ▶ Delivery with works calibration certification



No. 1540 105

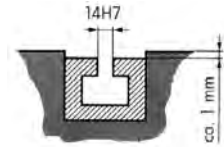

**I** Andere Größen, sowie zusätzliche T-Nuten und Messbänke aus Spezialguss auf Anfrage.

**I** Other sizes and additional T slots and benches made of special cast iron on request.

l. mm	kg	Nº
800 x 300 x 120	70,0	1540 101
1000 x 300 x 140	125,0	1540 102
1200 x 400 x 160	195,0	1540 103
1400 x 400 x 180	302,0	1540 104
1600 x 450 x 200	418,0	1540 105

l. mm	kg	Nº
2000 x 500 x 250	640,0	1540 106
2500 x 550 x 300	995,0	1540 107
3000 x 600 x 350	1570,0	1540 108
3500 x 600 x 350	2200,0	1540 109
4000 x 700 x 400	3360,0	1540 110

## Untergestelle für Messbänke aus Naturhartgestein

## Stands for test benches made of natural granite



- ▶ aus stabilem Vierkantrrohr, lackiert
- ▶ Baumaße für Arbeitshöhe von ca. 800mm
- ▶ Lieferung inkl. Lagergarnitur und Kippschutz (ab Nr. 1512 507 - 2 Stück)

- ▶ Stable square pipe, lacquered
- ▶ Construction dimensions for approx. 800mm working height
- ▶ Delivery incl. levelling screw and tilt protection (from No. 1512 507 - 2 pieces)

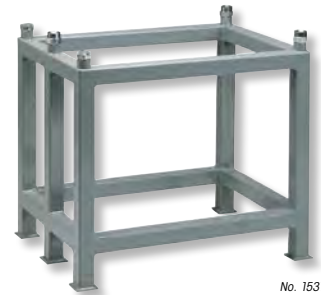

No. 1531 5..

für / for l. mm	Stück Piece	kg	Nº
800 x 300	1	21,0	1512 501
1000 x 300	1	25,0	1512 502
1200 x 400	1	28,0	1512 503
1400 x 400	1	30,0	1512 504
1600 x 450	1	36,0	1512 505
2000 x 500	1	44,0	1512 506
2500 x 550	2	42,0	1512 507
3000 x 600	2	55,0	1512 508
3500 x 600	2	60,0	1512 509
4000 x 700	2	70,0	1512 510

## Messtativ für Messbänke

## Dial gauge stands for test benches



- ▶ Querarm verschiebbar, mit Feineinstellung
- ▶ mit Oberflächenklemmung und 2 Nutsteinen 14mm
- ▶ Messuhraufnahme Ø 8mm
- ▶ Lieferung einzeln verpackt

- ▶ Adjustable arm with fine adjustment
- ▶ With surface clamping and 2 T-nuts 14mm
- ▶ Dial mounting hole Ø 8mm
- ▶ Delivered in individual packages

1547 1.. :

Messtativ Standard

1547 1.. :

Measuring stand standard

1548 1.. :

Messtativ, querverschiebbar mit Support

1548 1.. :

Measuring stand, movable with support

**I** Größere Messhöhen sowie Sonderstativ auf Anfrage.

**I** Larger measuring heights and special stands on request.

l. mm	h. mm	Ø mm	kg	Nº	Nº
200	200	16	6,0	1547 101	1548 101
300	200	20	6,0	1547 102	1548 102
400	200	20	7,0	1547 103	1548 103
600	250	20	9,0	1547 104	1548 104



No. 1547 101



No. 1548 102

## Messtativ Schwere Ausführung

## Dial gauge stands heavy duty



- ▶ Querarm verschiebbar, mit Feineinstellung
- ▶ mit schwerer Stahlbasis gehärtet, mit Staubnuten
- ▶ frei verschiebbar, ohne T-Nutführung
- ▶ Messuhraufnahme Ø 8mm
- ▶ Höhenverstellung durch Steilgewinde mit Stelling
- ▶ Lieferung einzeln verpackt

- ▶ Adjustable arm with fine adjustment
- ▶ With heavy hardened steel base, with dust grooves
- ▶ Free moveable, without T-slots
- ▶ Dial mounting hole Ø 8mm
- ▶ Height adjustment by helical thread with adjusting ring
- ▶ Delivered in individual packages

! Größere Messhöhen sowie Sonderstativ auf Anfrage.

! Larger measuring heights and special stands on request.

mm	mm	Ø mm	kg	Nº
500	300	35	12,0	1549 501



No. 1549 501

## Hand-Kniehebelpresse mit Richt-Vorrichtung aus Spezialguss

## Toggle press with straightening tool, Special cast iron



- ▶ Werksnorm
- ▶ Messfläche Güte 1, fein geschliffen
- ▶ Grundplatte mit T-Nute 10 H7
- ▶ mit Messstaster, Messuhraufnahme Ø8mm
- ▶ Lieferung einzeln verpackt ohne Messuhr

- ▶ Works standard
- ▶ Finely ground measuring face, grade 1
- ▶ Base plate with T-slots 10 H7
- ▶ With measuring probe, dial mounting hole Ø8mm
- ▶ Delivered in individual packages without dial gauge

### Inhalt:

- ▶ Handhebelpresse
- ▶ Grundplatte Länge 400mm mit T-Nute 10 H7
- ▶ Werkstückauflagen verschiebbar, 1 Paar
- ▶ Richtstempel
- ▶ Messstaster mit Messuhraufnahme Ø8mm (Nr. 1565 101)

### Contents:

- ▶ Toggle press
- ▶ Base plate length 400mm with T-slots 10 H7
- ▶ Moveable workpiece supports, 1 Pair
- ▶ Straightening punch
- ▶ Measuring probe with dial mounting hole Ø8mm (No. 1565 101)

Ideal für Werkstücke bis  $\varnothing \leq 10$ mm. Die benötigte Richtkraft ist von dem Werkstück- $\varnothing$ , der Werkstücklänge und dem Material abhängig.

Suitable for workpieces with  $\varnothing \leq 10$ mm. Measuring force depends on the workpiece- $\varnothing$ , the workpiece length and the material.

! Einzelteile auf Anfrage.

! Single parts on request.

mm	mm	kg	Nº
$\varnothing \leq 10$	400x80	10,0	1570 101



No. 1570 101

## Rundlaufprüfgeräte mit Abrollböcken

## Concentricity testers with balancing stands



- ▶ DIN 876
- ▶ Messflächen Güte 1, fein geschliffen
- ▶ Rundlaufgenauigkeit  $\pm 0,0025$ mm
- ▶ Abrollscheiben gehärtet, kugelgelagert
- ▶ ein Abrollbock höhenverstellbar, Verstellbereich ca. 50mm zum Ausgleich unterschiedlicher Werkstückdurchmesser
- ▶ Grundplatte mit 2 T-Nuten 12mm
- ▶ Stativ mit Feineinstellung, Messuhraufnahme Ø 8mm
- ▶ Lieferung im Etui, ohne Messuhr

- ▶ DIN 876
- ▶ Finely ground measuring faces, grade 1
- ▶ Concentricity accuracy  $\pm 0,0025$ mm
- ▶ Hardened rolling discs with ball bearings
- ▶ One rolling block height adjustable, range approx. 50mm for adjusting different workpiece diameter
- ▶ Base plate with 2 T-slots 12mm
- ▶ Stand with fine adjustment, dial mounting hole Ø 8mm
- ▶ Delivered in box without dial gauge

! Abrollböcke ohne Grundplatte auf Anfrage.

! Balancing stands without base plate on request.

mm	Prüfung/Test piece Ø mm	mm	kg	kg	Nº
120	5 - 240	540x150	18,0	31,7	1559 801
120	5 - 240	740x150	18,0	38,2	1559 802
120	5 - 240	1040x150	18,0	52,0	1559 803

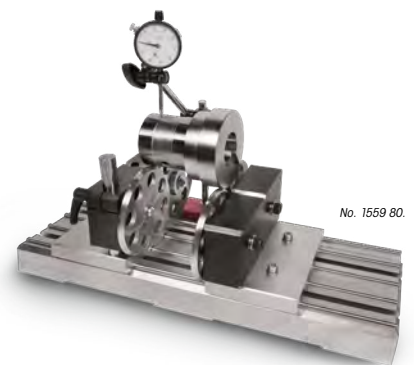

No. 1559 80.

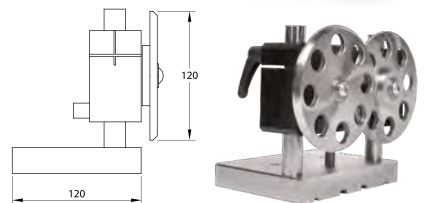

## Abrollböcke, Paar

## Balancing stands, pairs



- ▶ Werksnorm
- ▶ Gehäuse aus Spezialguss
- ▶ Standfläche geschliffen
- ▶ Abrollscheiben gehärtet, kugelgelagert
- ▶ Rundlaufgenauigkeit <0,005mm
- ▶ Lieferung paarweise verpackt

- ▶ Works standard
- ▶ Special cast-iron housing
- ▶ Ground base
- ▶ Hardened rolling discs with ball bearings
- ▶ Concentricity <0.005mm
- ▶ Delivered in packages (pair)

**1558 2.. :**  
Abrollböcke ohne T-Nutklemmung

**1558 2.. :**  
Balancing stands without T-slot clamping

**1558 3.. :**  
Aufpreis für Klemmung und T-Nutsteine 14mm

**1558 3.. :**  
Additional charges for clamping and T-slots 14mm

H1 mm	A min. mm	Prüfling Test piece Ø mm	↓ kg	↕ kg	Nº	Nº
219	45	100	10	8,0	1558 202	1558 301
335	70	150	100	20,0	1558 204	1558 302
480	80	200	400	56,0	1558 206	1558 303

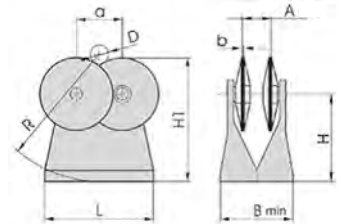

Messbänke siehe Seite 7.24  
Measuring benches see page 7.24

## Abrollböcke, Paar

## Rolling blocks, pair



- ▶ Werksnorm
- ▶ Gehäuse aus Spezialguss
- ▶ Standfläche fein geschliffen
- ▶ Rollen aus gehärtetem Stahl
- ▶ Rundlaufgenauigkeit <0,005mm
- ▶ Excenterspannung für Klemmung in T-Nuten
- ▶ T-Nutstein 14mm
- ▶ Lieferung paarweise verpackt

- ▶ Works standard
- ▶ Special cast-iron housing
- ▶ Finely ground base
- ▶ Hardened steel rollers
- ▶ Concentricity <0.005mm
- ▶ Exentric clamping for T nuts
- ▶ T-slots 14mm
- ▶ Delivered in a package (pair)

⊥ mm	Prüfling Test piece Ø mm	Nutsteine Slot mm	↓ kg	↕ kg	Nº
200	25 – 100	14h6	150	15,0	1558 701
200	25 – 150	14h6	150	15,0	1558 702



Messbänke siehe Seite 7.24  
Measuring benches see page 7.24

## Abrollböcke schwere Ausführung, Paar

## Rolling blocks heavy duty, pair



- ▶ Werksnorm
- ▶ Gehäuse aus Spezialguss
- ▶ Standfläche geschliffen
- ▶ Gehärteter Stahl, kugelgelagert
- ▶ Rundlaufgenauigkeit <0,005mm
- ▶ Excenterspannung für Klemmung in T-Nuten
- ▶ T-Nutensteine 14mm
- ▶ Lieferung paarweise verpackt

- ▶ Works standard
- ▶ Special cast-iron housing
- ▶ Ground base
- ▶ Hardened steel rollers with ball bearing
- ▶ Concentricity <0.005mm
- ▶ Exentric clamping for T-nuts
- ▶ T-slots 14mm
- ▶ Delivered in packages (pair)

**1558 501 – 1558 503 :**  
Abrollböcke, schwere Ausführung (Paar)

**1558 501 – 1558 503 :**  
Rolling blocks (pair)

**1558 601 – 1558 603 :**  
Abrollböcke, höhenverstellbar, Verstellbereich 25mm,  
zum Ausgleich unterschiedlicher Werkstück – Ø

**1558 601 – 1558 603 :**  
Rolling blocks, height adjustable, range 25mm  
for adjusting different workpiece – Ø

⊥ mm	Prüfling Test piece Ø mm	↓ kg	↕ kg	Nº	Nº
160	10 – 110	800	24,0	1558 501	1558 601
200	60 – 150	800	40,0	1558 502	1558 602
250	60 – 150	800	55,0	1558 503	1558 603



Messbänke siehe Seite 7.24  
Measuring benches see page 7.24

**Abrollböcke, Paar  
pendelnd gelagert**

**Balancing stands, pairs  
with floating base**



- ▶ Werksnorm
- ▶ Gehäuse aus Spezialguss
- ▶ Standfläche geschliffen
- ▶ Abrollwalzen gehärtet mit breiter Auflage, kugelgelagert
- ▶ Rundlaufgenauigkeit <0,01mm
- ▶ Lieferung paarweise verpackt

- ▶ Works standard
- ▶ Special cast-iron housing
- ▶ Ground base
- ▶ Extra-wide hardened rollers with ball bearings
- ▶ Concentricity <0.01 mm
- ▶ Delivered in packages (pair)

**!** Ausführung mit T-Nutsteinen und Klemmung auf Anfrage.

**!** Versions with T nuts and clamping on request.



No. 1558 402

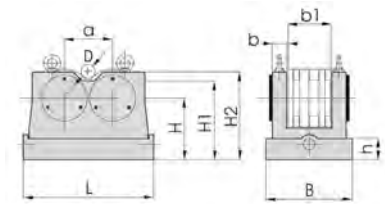

H1 mm	b mm	b1 mm	Ø mm	D	kg	kg	Nº
143	24	40	150		800	33,0	1558 401
153	34	70	150		2000	66,0	1558 402
180	40	90	250		5000	114,0	1558 403
200	45	114	250		10000	182,0	1558 404
272	60	150	250		25000	370,0	1558 405
302	82	180	300		50000	580,0	1558 406

**Rollenböcke, einzeln**

**Roller blocks, single**



- ▶ DIN 876
- ▶ Standfläche Güte 0, fein geschliffen
- ▶ Gehäuse aus Spezialguss
- ▶ Endmaßauflagen und Rollen, Spezialstahl gehärtet
- ▶ Einstellung durch Endmaße
- ▶ ab 250mm Achshöhe mit Verstellspindel
- ▶ Achsgenauigkeit 0,003mm
- ▶ Lieferung einzeln verpackt

- ▶ DIN 876
- ▶ Finely ground base, grade 0
- ▶ Special cast-iron housing
- ▶ Hardened special steel block bases and rollers
- ▶ Adjustment with gauge blocks
- ▶ Threaded spindle adjustment from 250mm axis height
- ▶ Axial accuracy 0.003mm
- ▶ Delivered in individual packages

**!** Auch paarweise lieferbar.

**!** Also available in pairs.



No. 1558 103

mm	mm	Werkstück / Workpiece Ø mm	kg	Nº	mm	mm	Werkstück / Workpiece Ø mm	kg	Nº
100	100 x 165	10 – 65	12,0	1558 101	300	220 x 450	25 – 170	75,0	1558 105
150	150 x 260	15 – 110	16,0	1558 102	400	240 x 660	35 – 240	110,0	1558 106
200	155 x 350	20 – 140	32,0	1558 103	500	300 x 965	50 – 300	140,0	1558 107
250	180 x 380	25 – 150	60,0	1558 104	600	330 x 980	80 – 360	170,0	1558 108

**Spindelstücke leichte Ausführung  
mit mechanischer Einstellvorrichtung**

**Headstocks, light model  
with mechanical adjusting device**



- ▶ DIN 876
- ▶ Standfläche Güte 0, feingeschliffen
- ▶ Gehäuse aus Spezialguss
- ▶ drehbare Spindel aus gehärtetem Stahl mit Klemmung
- ▶ Rundlaufgenauigkeit 0,004mm
- ▶ Teilscheibe und Nonius mattverchromt
- ▶ Anzeigebereich 0–360°
- ▶ Einstellgenauigkeit 3'
- ▶ Lieferung mit Zentrierspitze und Mitnehmerscheibe

- ▶ DIN 876
- ▶ Finely ground base, grade 0
- ▶ Special cast-iron housing
- ▶ Rotary, hardened steel spindle with clamping
- ▶ Concentricity 0.004mm
- ▶ Satin chrome index plate and vernier
- ▶ Range of indication 0–360°
- ▶ Adjustment accuracy 3'
- ▶ Delivered with centre point and carrier plate

**1556 3.. :**  
Einstellung über Handrad

**1556 3.. :**  
Adjustment with hand wheel

**1556 4.. :**  
zusätzlich Rastmechanismus Intervall 7,5°

**1556 4.. :**  
Additional stop mechanism, interval 7.5°

**!** Präzisionsspannfutter sowie Spannzangenaufnahme auf Anfrage.

**!** Precision chuck and collet attachment on request.



No. 1556 403

mm	Aufnahme / Shaft MK	mm	kg	Nº	Nº	mm	Aufnahme / Shaft MK	mm	kg	Nº	Nº
100	2	190	10,0	1556 301	1556 401	250	3	270	40,0	1556 304	1556 404
150	3	200	20,0	1556 302	1556 402	300	3	310	52,0	1556 305	1556 405
200	3	220	23,0	1556 303	1556 403						

## Spindelstöcke mit elektronischer Ables- und Einstellvorrichtung

## Headstocks with electronic reading and adjusting device



- ▶ DIN 876
- ▶ Standfläche Güte 0, fein geschliffen
- ▶ Gehäuse aus Spezialguss
- ▶ drehbare Spindel aus gehärtetem Stahl mit Klemmung
- ▶ Rundlaufgenauigkeit 0,002mm
- ▶ Teilscheibe und Nonius mattverchromt
- ▶ Anzeigebereich 0–360°
- ▶ kleinstes Intervall 0,0005° (1'')
- ▶ 2 stufiges Feingetriebe zuschaltbar  
Untersetzung 62:1 oder 372:1
- ▶ Lieferung mit Zentrierspitze und Mitnehmerscheibe

**!** Präzisionsspannfutter, sowie Spannzangenaufnahme auf Anfrage.

**!** Größere Achshöhe, motorischer Antrieb sowie hydraulischer Pinolenvorschub auf Anfrage.

- ▶ DIN 876
- ▶ Finely ground base, grade 0
- ▶ Special cast-iron housing
- ▶ Rotary, hardened steel spindle with clamping
- ▶ Concentricity 0.002mm
- ▶ Satin chrome index plate and vernier
- ▶ Range of indication 0–360°
- ▶ Smallest interval 0.0005° (1'')
- ▶ Switchable 2-step gear  
Reduction 62:1 or 372:1
- ▶ Delivered incl. centre point and carrier plate

**!** Precision chuck and collet attachment on request.

**!** Larger axis heights, motor drive and hydraulic sleeve feed on request.



No. 1557 103

∅ mm	Aufnahme / Shaft MK	l-l mm	∅ kg	№	
150	4	400	70,0	1557 101	
200	5	500	100,0	1557 102	
250	5	500	115,0	1557 103	
300	5	600	130,0	1557 104	

## Spindelstöcke mit mechanischer Einstellvorrichtung

## Headstocks with mechanical adjusting device



- ▶ DIN 876
- ▶ Standfläche Güte 0, fein geschliffen
- ▶ Gehäuse aus Spezialguss
- ▶ drehbare Spindel aus gehärtetem Stahl mit Klemmung
- ▶ Rundlaufgenauigkeit 0,002mm
- ▶ Teilscheibe und Nonius mattverchromt
- ▶ Anzeigebereich 0–360°
- ▶ Einstellgenauigkeit 3'
- ▶ Lieferung mit Zentrierspitze und Mitnehmerscheibe

**1556 1.. :**  
Einstellung über Handrad

**1556 2.. :**  
zusätzlich Rastmechanismus Intervall 7,5°

**!** Präzisionsspannfutter, sowie Spannzangenaufnahme auf Anfrage.

**!** Größere Achshöhe, motorischer Antrieb sowie hydraulischer Pinolenvorschub auf Anfrage.

- ▶ DIN 876
- ▶ Finely ground base, grade 0
- ▶ Special cast-iron housing
- ▶ Rotary, hardened steel spindle with clamping
- ▶ Concentricity 0.002mm
- ▶ Satin chrome index plate and vernier
- ▶ Range of indication 0–360°
- ▶ Adjustment accuracy 3'
- ▶ Delivered with centre point and carrier plate

**1556 1.. :**  
Adjustment with hand wheel

**1556 2.. :**  
Additional stop mechanism, interval 7.5°

**!** Precision chuck and collet attachment on request.

**!** Larger axis heights, motor drive and hydraulic sleeve feed on request.



No. 1556 103

∅ mm	Aufnahme / Shaft MK	l-l mm	∅ kg	№	№
150	4	300	40,0	1556 101	1556 201
200	5	400	70,0	1556 102	1556 202
250	5	500	85,0	1556 103	1556 203
300	5	600	100,0	1556 104	1556 204

## Reitstöcke für Spindelstöcke

## Tailstocks for headstocks



- ▶ DIN 876
- ▶ Standfläche Güte 0, fein geschliffen
- ▶ Gehäuse aus Spezialguss
- ▶ bewegliche Pinole, arretierbar,  
Verstellung durch Handrad
- ▶ Achsgenauigkeit 0,003mm
- ▶ Lieferung mit Zentrierspitze

- ▶ DIN 876
- ▶ Finely ground base, grade 0
- ▶ Special cast-iron housing
- ▶ Hand-wheel adjusted, movable  
and lockable sleeve
- ▶ Axial accuracy 0.003 mm
- ▶ Delivered with centre point

∅ mm	Aufnahme / Shaft MK	l-l mm	∅ kg	№	∅ mm	Aufnahme / Shaft MK	l-l mm	∅ kg	№
100	2	150	5,0	1556 500	250	3	250	28,0	1556 503
150	2	180	13,0	1556 501	300	3	285	40,0	1556 504
200	2	195	15,0	1556 502					



No. 1556 502

# 8

## Lehenschraubstöcke

Precision vices

## Sinustische

Sine tables

## Aufspannwinkel

Angle plates

## Winkelnormale

Master squares

## Prismen

V-Blocks

## Parallelunterlagen, Messbalken

Parallel supports, Straightedges

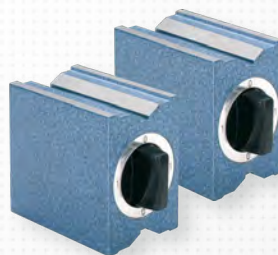

### TOP

Präzisionsschraubstöcke MINI  
Precision vices MINI



8.4

Sinustische  
Sine tables



8.5

Aufspannwinkel  
Angle plates



8.7

Winkelnormale 90°  
Master squares 90°



8.11



+49 (0) 60 21 42 999 00

1

2

3

4

5

6

7

8

9

10

11

12

13

14

15

## Lehenschraubstöcke mit Schnellverstellung

## Precision vices with quick adjustment



**Gehärtet  
Hardened**

- ▶ Werksnorm
- ▶ Genauigkeit 0,003mm / 100mm
- ▶ Spezialstahl gehärtet und geschliffen
- ▶ 4-seitige Werkstückbearbeitung
- ▶ keine störende Gewindespindel
- ▶ Lieferung einzeln verpackt

- ▶ Works standard
- ▶ Accuracy 0.003mm / 100mm
- ▶ Hardened and ground special steel
- ▶ 4-side workpiece machining
- ▶ No interfering threaded spindle
- ▶ Delivered in individual packages

**1584 1.. :**

Lehenschraubstöcke

**1584 1.. :**

Vices

**1585 1.. :**

1 Paar Spannbacken mit 2 prismatischen Einschnitten

**1585 1.. :**

1 pair clamping jaws with 2 V grooves

M mm	B mm	H1 mm	H2 mm	L mm	█ kg	Nº	Nº
60	60	22	55	158	3,0	1584 101	1585 101
80	80	30	80	210	7,0	1584 102	1585 102
125	100	40	100	285	14,0	1584 104	1585 104
160	150	40	90	330	18,0	1584 105	1585 105

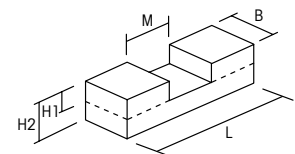
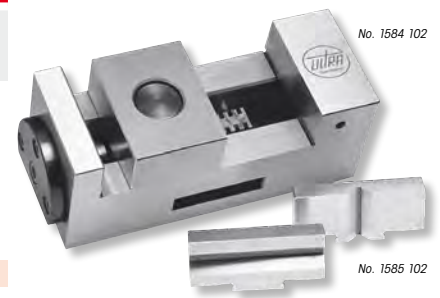

## Niederzug-Spannstock mit Schnellverstellung

## Pull-down vices with quick adjustment



**Gehärtet  
Hardened**

- ▶ Werksnorm
- ▶ Genauigkeit 0,01mm / 100mm
- ▶ Spezialstahl gehärtet und geschliffen
- ▶ 4-seitige Werkstückbearbeitung
- ▶ 1 Backen mit 2 prismatischen Einschnitten
- ▶ keine störende Gewindespindel
- ▶ Lieferung einzeln verpackt

- ▶ Works standard
- ▶ Accuracy 0.01mm / 100mm
- ▶ Hardened and ground special steel
- ▶ 4-side workpiece machining
- ▶ 1 jaw with 2 V grooves
- ▶ No interfering threaded spindle
- ▶ Delivered in individual packages

M mm	B mm	H1 mm	H2 mm	L mm	█ kg	Nº
32	25	12	20	75	1,0	1584 501
65	50	25	50	140	3,0	1584 502
85	63	32	63	175	7,0	1584 503
100	73	35	70	190	11,0	1584 504
125	100	45	90	245	14,0	1584 505
160	125	50	100	285	15,0	1584 506

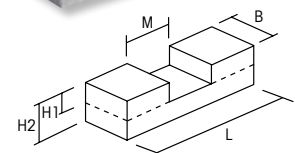
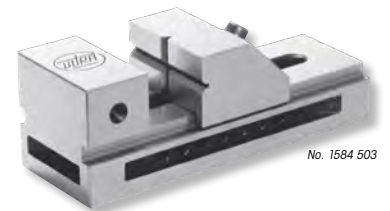

## Lehenschraubstöcke mit Gewindespindel

## Precision vices with threaded spindle



**Gehärtet  
Hardened**

- ▶ Werksnorm
- ▶ Genauigkeit 0,005mm / 100mm
- ▶ Spezialstahl gehärtet und geschliffen
- ▶ 4-seitige Werkstückbearbeitung
- ▶ Lieferung einzeln verpackt

- ▶ Works standard
- ▶ Accuracy 0.005mm / 100mm
- ▶ Hardened and ground special steel
- ▶ 4-side workpiece machining
- ▶ Delivered in individual packages

M mm	B mm	H1 mm	H2 mm	L mm	█ kg	Nº
30	60	25	50	90	1,5	1586 101
80	70	30	62	160	3,6	1586 102
95	73	32	65	175	4,3	1586 103

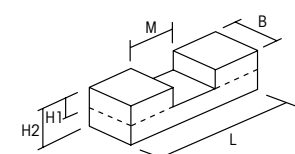
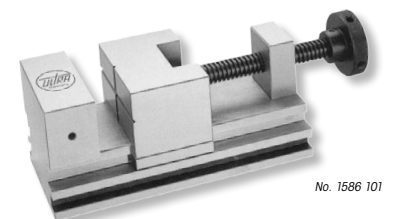



## Lehenschraubstöcke mit Gewindespindel und Sinusfunktion

## Precision vices with threaded spindle and sine function



**Gehärtet  
Hardened**

- ▶ Werksnorm
- ▶ Genauigkeit 0,005mm / 100mm
- ▶ Spezialstahl gehärtet und geschliffen
- ▶ Lieferung einzeln verpackt

- ▶ Works standard
- ▶ Accuracy 0.005mm / 100mm
- ▶ Hardened and ground special steel
- ▶ Delivered in individual packages

M mm	B mm	H1 mm	H2 mm	L mm	kg	Nº
70	63	30	96	175	5,0	1587 101
75	73	30	103	180	7,0	1587 102
dreh- und schwenkbar / rotating and tilting						
80	70	30	137	137	12,0	1587 201

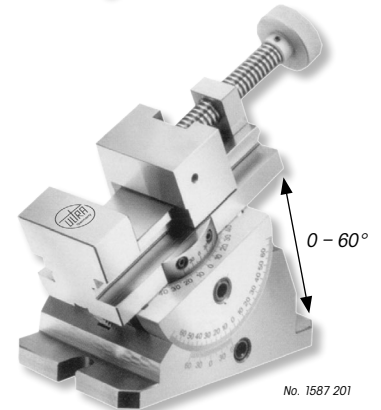
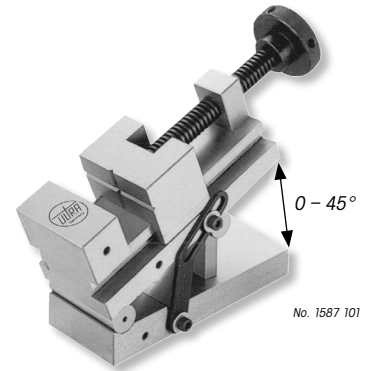
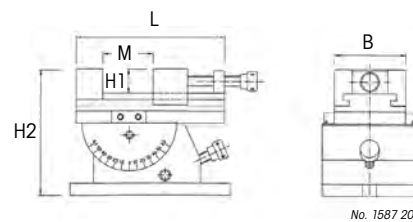
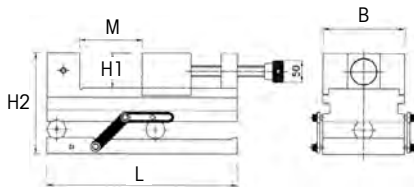

## Präzisionsschraubstöcke MINI mit Gewindespindel

## Precision vices MINI with threaded spindle



**TOP**

- ▶ Werksnorm
- ▶ als Spannhilfe für Messmikroskope, Profilprojektoren, Rauheitsmessgeräte etc.
- ▶ Genauigkeit 0,02 / 100mm
- ▶ 1 Backen mit 2 prismatischen Einschnitten
- ▶ Lieferung einzeln verpackt

- ▶ Works standard
- ▶ Clamping device for microscopes, profile projectors, roughness testers etc.
- ▶ Accuracy 0.02 / 100mm
- ▶ 1 jaw with 2 V grooves
- ▶ Delivered in individual packages

**1457 101 :**

Messing mattverchromt

**1457 101 :**

Satin chrome brass

**1457 102 / 1457 103 :**

Aluminium eloxiert

**1457 102 / 1457 103 :**

Aluminium anodized

**1457 2.. :**

rostfreier Stahl gehärtet

**1457 2.. :**

Stainless steel hardened

M mm	B mm	H1 mm	H2 mm	L mm	kg	Nº	Nº
14	15	8	15	50	0,2	1457 101	1457 201
25	25	15	25	75	0,5	1457 102	1457 202
32	35	10	35	100	0,8	1457 103	1457 203

Stativ dreh- und schwenkbar / Stand rotating and tilting

für Nr. 1457 101 und Nr. 1457 201 / for No. 1457 101 and No. 1457 201

**1457 901**

für Nr. 1457 102 und Nr. 1457 202 / for No. 1457 102 and No. 1457 202

**1457 902**

für Nr. 1457 103 und Nr. 1457 203 / for No. 1457 103 and No. 1457 203

**1457 903**

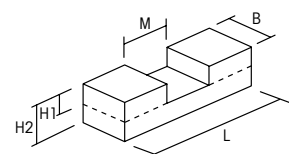

Sätze und Zubehör auf Anfrage.  
Sets and accessories on request.

## Präzisionsschraubstöcke MINI im Satz mit Gewindespindel

## Precision vices MINI, Set with threaded spindle



- ▶ Werknorm
- ▶ als Spannhilfe für Messmikroskope, Profilprojektoren, Rauheitsmessgeräte etc.
- ▶ Genauigkeit 0,02 / 100mm
- ▶ 1 Backen mit 2 prismatischen Einschnitten
- ▶ Lieferung im Koffer

### Inhalt:

- ▶ je 1 Stück MINI Präzisionsschraubstock Nr. 1457 101, 1457 102 und 1457 103
- ▶ 1 Paar Kunststoffbacken
- ▶ 1 Paar Stufenbacken
- ▶ 1 Stück Prismabacke mit Anschlagstift

**I** Andere Satzzusammenstellungen auf Anfrage

- ▶ Works standard
- ▶ Clamping device for microscopes, profile projectors, roughness testers etc.
- ▶ Accuracy 0.02 / 100mm
- ▶ 1 jaw with 2 V grooves
- ▶ Delivered in a box

### Contents:

- ▶ 1 piece of each MINI precision vices No. 1457 101, 1457 102 and 1457 103
- ▶ 1 pair plastic jaws
- ▶ 1 pair 2-level jaws
- ▶ 1 piece jaw with V grooves

**I** Other set compositions on request



kg	Nº
1,0	1457 501

## Sonderprüfvorrichtungen

## Custom made measuring devices



Wir liefern jede Art von Sonderprüfvorrichtungen für Ihren speziellen Anwendungsfall – auf Wunsch auch Konzeption und Konstruktion, gegen Berechnung.

Zur Angebotserstellung bitten wir um Ihre Anfragen mit Zeichnungsunterlagen.

**Beispiele für bereits realisierte kundenspezifische Sonderlösungen:**

We supply all types of custom made measuring devices for your special applications – on request also undertake conception and design at a cost.

For the preparation of a quotation, please send us your inquiries with drawings.

**Examples of already executed customer-specific special solutions:**

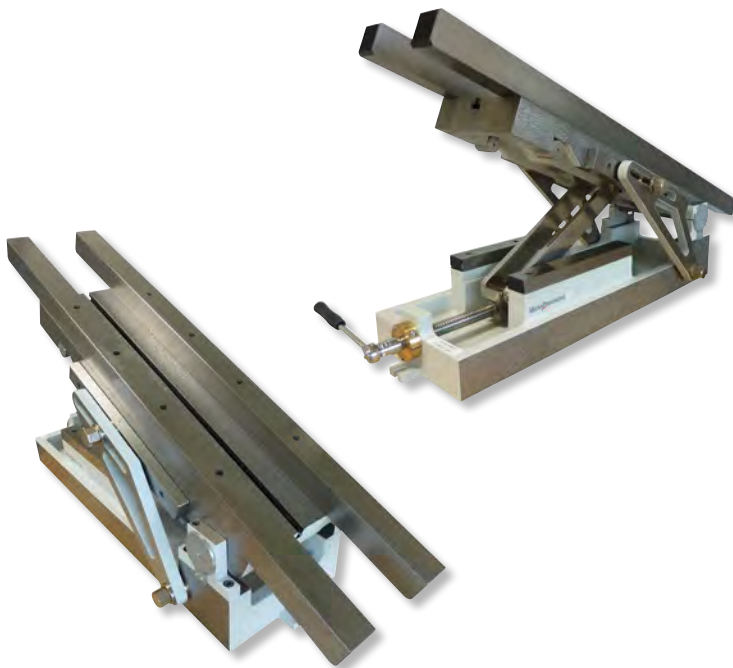

*Sonderanfertigung Sinustisch mit Werkstückauflage 1000mm*

*Special designed sine table with 1000mm work piece table*



*Sonderanfertigung Winkelplatte mit Sinuslineal*

*Special designed angle plate with sine bar*

**Präzisionsschraubstock STANDARD  
mit Gewindespindel**

**Precision vices, STANDARD  
with threaded spindle**



**TOP**



**Gehärtet  
Hardened**

- ▶ Werksnorm
- ▶ Genauigkeit 0,01mm / 100mm
- ▶ Spezialstahl gehärtet und geschliffen
- ▶ 1 Backen mit 2 prismatischen Einschnitten
- ▶ Lieferung einzeln verpackt

- ▶ Works standard
- ▶ Accuracy 0.01mm / 100mm
- ▶ Hardened and ground special steel
- ▶ 1 jaw with 2 V grooves
- ▶ Delivered in individual packages

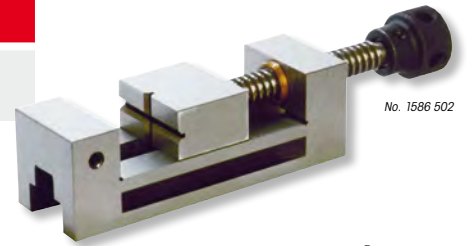

No. 1586 502

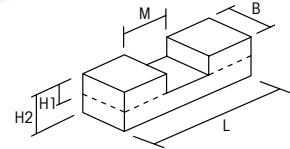

M mm	B mm	H1 mm	H2 mm	L mm	⚖ kg	Nº
65	50	25	50	155	3,0	1586 501
85	63	32	63	190	7,0	1586 502
100	73	35	70	210	11,0	1586 503
125	88	40	80	250	14,0	1586 504
125	100	45	90	260	15,0	1586 505

**Sinustische  
mit Magnetspannplatte**

**Sine tables  
with magnetic plates**



**Gehärtet  
Hardened**

- ▶ Werksnorm
- ▶ Spezialstahl gehärtet und geschliffen
- ▶ Magnetplatte ein-/ausschaltbar
- ▶ Querpoltteilung 1,9mm
- ▶ Winkelgenauigkeit ±5'
- ▶ Schwenkbereich 0 – 45° Sinusprinzip
- ▶ Planparallelität 0,005mm / 100mm
- ▶ Lieferung einzeln verpackt inkl. Sinustabelle

- ▶ Works standard
- ▶ Hardened and ground special steel
- ▶ Switchable magnetic plate
- ▶ Pole pitch 1.9mm
- ▶ Angular accuracy ±5'
- ▶ Pivoting range 0 – 45° sine principle
- ▶ Plane parallelism 0.005mm / 100mm
- ▶ Delivered in individual packages incl. sine table



No. 1452 102



No. 1453 102



No. 1454 102

! Andere Größen auf Anfrage.

! Other sizes on request.

■ mm	⊥ mm	Rollenabstand / Roller distance mm	⚖ kg	Nº
kurze Seite ist Achsseite / Short side is axis side				
175x100	80	175	13,0	1452 101
255x130	80	255	23,0	1452 102
300x150	83	300	30,0	1452 103
400x200	83	400	58,0	1452 104
lange Seite ist Achsseite / Long side is axis side				
175x100	80	100	13,0	1453 101
255x130	80	130	23,0	1453 102
300x150	83	150	30,0	1453 103
400x200	83	200	58,0	1453 104
2 Ebenen schwenkbar / 2 levels adjustable				
175x100	107	100/175	17,0	1454 101
255x130	107	130/255	29,0	1454 102
300x150	110	150/300	44,0	1454 103
400x200	110	200/400	70,0	1454 104

**Magnetspannplatte**

**Magnetic clamping plates**



**Gehärtet  
Hardened**

- ▶ Werksnorm
- ▶ Spezialstahl gehärtet und geschliffen
- ▶ Magnetplatte ein-/ausschaltbar
- ▶ Planparallelität 0,005mm / 100mm
- ▶ Lieferung einzeln verpackt

- ▶ Works standard
- ▶ Hardened and ground special steel
- ▶ Switchable magnetic plate
- ▶ Plane parallelism 0.005mm / 100mm
- ▶ Delivered in individual packages

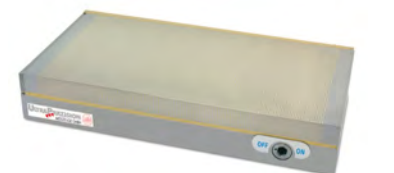

No. 1455 10

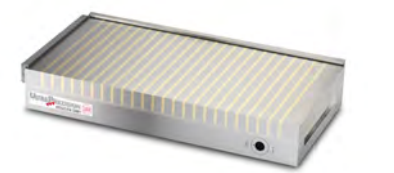

No. 1455 20

**P = Querpoltteilung**

**P = Pole pitch**

! Andere Größen auf Anfrage.

! Other sizes on request.

⊥ mm	⚖ kg	■ mm	P mm	Nº	⊥ mm	■ mm	P mm	Nº
48	6,0	175x100	1,9	1455 101	-	-	-	-
48	10,0	255x130	1,9	1455 102	60	250x150	15	1455 202
51	20,0	300x150	1,9	1455 103	60	300x150	15	1455 203
51	36,0	400x200	1,9	1455 104	60	400x200	15	1455 204

## Lamellenblöcke für Magnetspannplatten

## Lamellar blocks for magnetic clamping plates



- ▶ Lamellen 2mm Messing, 4mm Stahl
- ▶ Lieferung einzeln verpackt

- ▶ Lamellars 2mm brass, 4mm steel
- ▶ Delivered in individual packages

**!** Lamellen müssen parallel zu den Polen der Platte ausgerichtet sein, die Polteilung der Blöcke muss kleiner sein als die der Magnetspannplatte.

**!** Lamellars should be aligned to the poles of the plate, and the pole pitch of the blocks must be smaller than that of the magnetic plate.

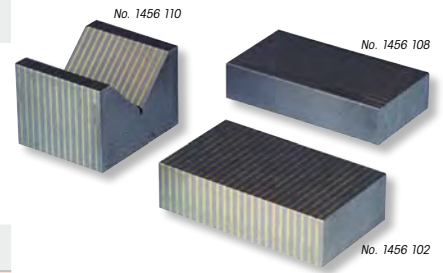

l <sub>z</sub> mm	Typ Type	ḡ kg	Nº
80x60x30	Querpol / Cross pole	1,1	1456 102
100x50x40	Längspol / Length pole	1,1	1456 108
100x50x40	Prisma + Querpol / Prism + Cross pole	2,1	1456 110

## Sinustische aus Spezialguss

## Sine tables Special cast iron



**Gehärtet  
Hardened**

- ▶ Werksnorm
- ▶ Schwenkbereich 0 – 60° Sinusprinzip
- ▶ Endmaßauflagen gehärtet und geschliffen
- ▶ Spannfläche mit T-Nuten DIN 650 H6
- ▶ Lieferung einzeln verpackt inkl. Sinustabelle

- ▶ Works standard
- ▶ Pivoting range 0 – 60° sine principle
- ▶ Hardened and ground gauge block base
- ▶ Clamping surface with T slots DIN 650 H6
- ▶ Delivered in individual packages incl. sine table

**1588 1.. / 1590 1.. :**  
Güte 0 – Gen. 0,005/100mm

**1588 1.. / 1590 1.. :**  
Grade 0 – Acc. .005/100mm

**1589 1.. / 1591 1.. :**  
Güte 1 – Gen. 0,01/100mm

**1589 1.. / 1591 1.. :**  
Grade 1 – Acc. .01/100mm

■ mm	┌ mm	Rollenabstand Roller distance mm	T-Nuten T-slots Stück / Pieces	T-Nuten T-slots mm	ḡ kg	⓪ 0 Nº	⓪ 1 Nº
kurze Seite ist Achsseite / Short side is axis side							
120x85	54	100	1	8	5,0	1588 101	1589 101
220x160	75	150	3	10	20,0	1588 102	1589 102
275x200	85	200	3	10	30,0	1588 103	1589 103
2 Ebenen schwenkbar / 2 levels adjustable							
200x100	122	150 / 65	1	10	12,0	1590 101	1591 101
250x150	128	200 / 100	2	10	27,0	1590 102	1591 102
275x200	140	200 / 150	3	10	40,0	1590 103	1591 103



No. 1588 102



No. 1590 102

**Winkelaufspanntische aus Spezialguss**

**Angle clamping tables Special cast iron**

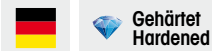

- ▶ Werksnorm
- ▶ Einstellung mit Gradskala und Nonius 3'
- ▶ Sinuseinstellbereich 0 – 60°
- ▶ Endmaßauflagen gehärtet und geschliffen
- ▶ Spannfläche mit T-Nuten
- ▶ Klemmung mit seitlichen Bügeln
- ▶ ab Größe 400x300mm mit Verstellspindel
- ▶ Lieferung einzeln verpackt inkl. Sinustabelle

- ▶ Works standard
- ▶ Adjustment with scale and vernier 3'
- ▶ Sine adjustment range 0 – 60°
- ▶ Hardened and ground gauge block bases
- ▶ Clamping surface with T slots
- ▶ Clamping with side clamps
- ▶ From size 400x300mm with threaded spindle
- ▶ Delivered in individual packages inc. sine table

**1594 1.. / 1594 2.. :**  
Schwenkbereich 0 – 90°

**1594 1.. / 1594 2.. :**  
Pivoting range 0 – 90°

**1593 3.. / 1593 4.. :**  
Schwenkbereich 0 – 60°

**1593 3.. / 1593 4.. :**  
Pivoting range 0 – 60°



! Ausführungen mit der kurzen Seite als Achsseite auf Anfrage.

! Versions with short side as axis side on request.

■ mm	□ mm	Rollenabstand Roller distance mm	T-Nuten T-slots Stück/ Pieces	T- Nuten T-slots mm	⌀ kg	∠ mm	Nº	∠ mm	Nº
lange Seite ist Achsseite / Long side is axis side									
200x150	83	100	1	10	18,0	0,003	<b>1594 101</b>	0,006	<b>1594 201</b>
300x200	85	150	2	12	28,0	0,003	<b>1594 102</b>	0,006	<b>1594 202</b>
400x200	100	150	2	12	36,0	0,004	<b>1594 103</b>	0,008	<b>1594 203</b>
400x300	110	200	3	14	65,0	0,004	<b>1594 104</b>	0,008	<b>1594 204</b>
2 Ebenen schwenkbar / 2 levels adjustable									
200x150	130	150 / 100	1	10	20,0	0,003	<b>1593 301</b>	0,006	<b>1593 401</b>
300x200	170	200 / 150	2	12	60,0	0,003	<b>1593 302</b>	0,006	<b>1593 402</b>
400x300	175	300 / 200	3	14	90,0	0,004	<b>1593 303</b>	0,008	<b>1593 403</b>

**Aufspannwinkel aus Spezialguss mit Spannschlitz**

**Angle plates, special cast iron with clamping slots**



- ▶ DIN 875 / DIN 876
- ▶ 2-seitig bearbeitet
- ▶ Spannfläche und Standfläche mit Spannschlitz
- ▶ rückseitig mit Rippen verstärkt
- ▶ Lieferung einzeln verpackt

- ▶ DIN 875 / DIN 876
- ▶ 2-sides machined
- ▶ Clamping surface and base with clamping slots
- ▶ Backside reinforced with ribs
- ▶ Delivered in individual packages

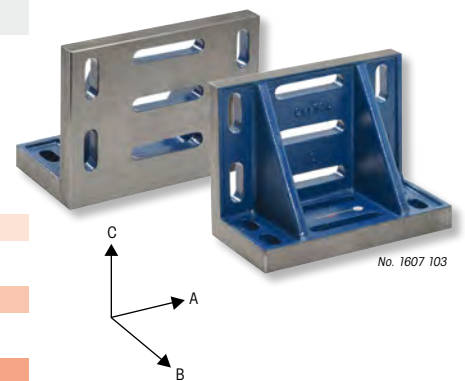

**1605 1.. :**  
Güte 0 (feinst geschliffen)

**1605 1.. :**  
Grade 0 (fine grinded)

**1607 1.. :**  
Güte 1 (geschliffen)

**1607 1.. :**  
Grade 1 (grinded)

**1609 1.. :**  
Güte 3 (gefräst / gehobelt)

**1609 1.. :**  
Grade 3 (milled / planed)

! Größere Abmessungen, höhere Genauigkeit sowie sechsseitige Bearbeitung auf Anfrage.

! Larger dimensions, higher accuracy and 6-side machining on request.

A x B x C mm	Schlitzbreite Slot width mm	⌀ kg	☉ 0 Nº	☉ 1 Nº	☉ 3 Nº	A x B x C mm	Schlitzbreite Slot width mm	⌀ kg	☉ 0 Nº	☉ 1 Nº	☉ 3 Nº
150 x 75 x 100	16	4,0	<b>1605 101</b>	<b>1607 101</b>	<b>1609 101</b>	500 x 300 x 400	24	65,0	<b>1605 106</b>	<b>1607 106</b>	<b>1609 106</b>
200 x 100 x 150	16	8,0	<b>1605 102</b>	<b>1607 102</b>	<b>1609 102</b>	600 x 350 x 500	24	146,0	-	-	<b>1609 107</b>
275 x 150 x 200	20	20,0	<b>1605 103</b>	<b>1607 103</b>	<b>1609 103</b>	800 x 450 x 600	24	220,0	-	-	<b>1609 108</b>
400 x 225 x 300	24	40,0	<b>1605 105</b>	<b>1607 105</b>	<b>1609 105</b>	1000 x 600 x 800	30	431,0	-	-	<b>1609 109</b>

## Aufspannwinkel aus Spezialguss mit T-Nuten

## Angle plates, special cast iron with T slots



- ▶ DIN 875 / DIN 876
- ▶ 2-seitig bearbeitet
- ▶ Spannfläche mit T-Nuten DIN 650 H8
- ▶ Standfläche mit Spannschlitz
- ▶ rückseitig mit Rippen verstärkt
- ▶ Lieferung einzeln verpackt

- ▶ DIN 875 / DIN 876
- ▶ 2-sides machined
- ▶ Clamping surface with T slots DIN 650 H8
- ▶ Base with clamping slots
- ▶ Backside reinforced with ribs
- ▶ Delivered in individual packages

**1611 1.. :**  
Güte 0 (feinst geschliffen)

**1611 1.. :**  
Grade 0 (fine grinded)

**1613 1.. :**  
Güte 1 (geschliffen)

**1613 1.. :**  
Grade 1 (grinded)

**1615 1.. :**  
Güte 3 (gefräst / gehobelt)

**1615 1.. :**  
Grade 3 (milled / planed)

! Größere Abmessungen, höhere Genauigkeit sowie sechsseitige Bearbeitung auf Anfrage.

! Larger dimensions, higher accuracy and 6-side machining on request.

A x B x C mm	T-Nuten / T-slots Stück / Pieces	T-Nuten / T-slots mm	kg	GG 0 N°	GG 1 N°	GG 3 N°
150x75x100	2	14	6,0	1611 101	1613 101	1615 101
200x100x150	2	14	11,0	1611 102	1613 102	1615 102
275x150x200	2	14	24,0	1611 103	1613 103	1615 103
400x225x300	3	18	50,0	1611 105	1613 105	1615 105
500x300x400	4	18	85,0	1611 106	1613 106	1615 106
600x350x500	4	18	180,0	-	-	1615 107

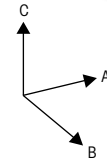
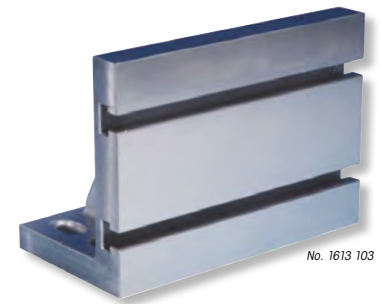

## Parallelkastenpaare aus Spezialguss

## Parallel box pairs special cast iron



- ▶ DIN 875 / DIN 876
- ▶ 4-seitig bearbeitet
- ▶ Lieferung paarweise verpackt

- ▶ DIN 875 / DIN 876
- ▶ 4-side machining
- ▶ Delivery in a package (pair)

**1619 1.. / 1625 1.. :**  
Güte 0 (feinst geschliffen)

**1619 1.. / 1625 1.. :**  
Grade 0 (fine grinded)

**1621 1.. / 1627 1.. :**  
Güte 1 (geschliffen)

**1621 1.. / 1627 1.. :**  
Grade 1 (grinded)

**1623 1.. / 1629 1.. :**  
Güte 3 (gefräst / gehobelt)

**1623 1.. / 1629 1.. :**  
Grade 3 (milled / planed)

! Größere Abmessungen sowie Sonderanfertigungen nach Ihren Vorgaben auf Anfrage.

! Larger sizes and special designs according to your specifications on request.

A x B x C mm	kg	GG 0 N°	GG 1 N°	GG 3 N°
glatte Messflächen / Plain measuring surfaces				
150x150x100	25,0	1619 101	1621 101	1623 101
225x150x100	41,0	1619 102	1621 102	1623 102
300x225x150	120,0	1619 103	1621 103	1623 103
400x300x200	160,0	1619 104	1621 104	1623 104
2 Messflächen mit Spann-T-Nuten / 2 measuring surfaces with clamping T-slots				
150x150x100	25,0	1625 101	1627 101	1629 101
225x150x100	41,0	1625 102	1627 102	1629 102
300x225x150	120,0	1625 103	1627 103	1629 103
400x300x200	160,0	1625 104	1627 104	1629 104

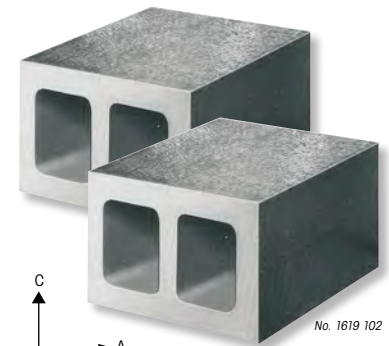

**Aufspannwürfel aus Spezialguss mit T-Nuten und Spannschlitzten**

**Clamping cubes, special cast iron with T slots and clamping slots**



- ▶ DIN 875 / DIN 876
- ▶ Standfläche und 3 Seitenflächen Güte 3 mit Spannschlitzten
- ▶ Spannfläche mit 3 Stück T-Nuten DIN 650 H12
- ▶ 1 Seitenfläche offen
- ▶ Lieferung einzeln verpackt

! Größere Abmessungen, höhere Genauigkeit sowie mehrere maßgleich bearbeitete Würfel auf Anfrage.

- ▶ DIN 875 / DIN 876
- ▶ Base and 3 side faces with clamping slots, grade 3
- ▶ Clamping surface with 3 pcs. T slots DIN 650 H12
- ▶ 1 open side face
- ▶ Delivered in individual packages

! Larger dimensions, higher accuracy and several cubes machined in the same dimensions on request.

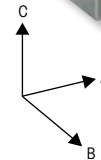
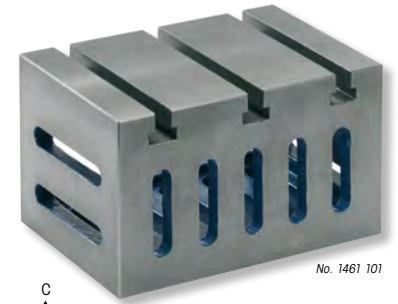

A x B x C mm	T-Nuten / T-slots mm	Schlitzbreite / Slot width mm	kg	Nº
250x180x150	14	16	26,0	1461 101
300x220x200	14	18	40,0	1461 102
350x280x250	22	22	75,0	1461 103
400x350x300	22	22	100,0	1461 104
500x450x400	22	22	180,0	1461 105

**Kastenwürfel aus Spezialguss mit Spannschlitzten**

**Clamping cubes, special cast iron with clamping slots**



- ▶ DIN 875 / DIN 876
- ▶ 4 Seitenflächen mit Spannschlitzten
- ▶ 2 Seitenflächen offen
- ▶ Lieferung einzeln verpackt

1462 1.. :  
Güte 1 (geschliffen)

1462 2.. :  
Güte 3 (gefräst / gehobelt)

! Größere Abmessungen, höhere Genauigkeit sowie mehrere maßgleich bearbeitete Würfel auf Anfrage.

- ▶ DIN 875 / DIN 876
- ▶ 4 side faces with clamping slots
- ▶ 2 open side faces
- ▶ Delivered in individual packages

1462 1.. :  
Grade 1 (grinded)

1462 2.. :  
Grade 3 (milled / planed)

! Larger dimensions, higher accuracy and several cubes machined in the same dimensions on request.

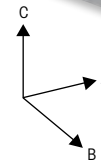
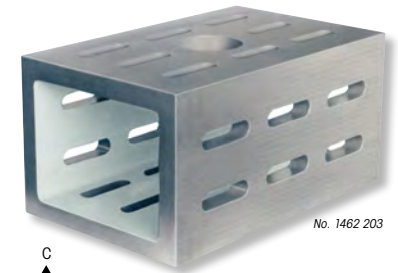

A x B x C mm	Schlitzbreite Slot width mm	kg	1 Nº	3 Nº	A x B x C mm	Schlitzbreite Slot width mm	kg	1 Nº	3 Nº
250x150x100	18	10,0	1462 101	1462 201	600x350x250	22	120,0	1462 105	1462 205
300x200x150	18	20,0	1462 102	1462 202	800x500x400	24	400,0	1462 106	1462 206
400x250x200	20	50,0	1462 103	1462 203	1000x600x500	30	600,0	1462 107	1462 207
500x300x250	22	85,0	1462 104	1462 204					

## Winkelplatten 90° aus Spezialguss



- ▶ DIN 875 / DIN 876
- ▶ Lieferung einzeln verpackt

**1600 1.. :**  
Güte 0 (feinst geschliffen)

**1601 1.. :**  
Güte 1 (geschliffen)

! Paarweise Bearbeitung auf Anfrage.

AxBxC mm	h kg	0 N°	1 N°
150x100x60	4,0	1600 101	1601 101
200x150x80	7,0	1600 102	1601 102
300x250x100	12,0	1600 103	1601 103

## Master squares 90° special cast iron

- ▶ DIN 875 / DIN 876
- ▶ Delivered in individual package

**1600 1.. :**  
Grade 0 (fine grinded)

**1601 1.. :**  
Grade 1 (grinded)

! Machining in pairs on request.

AxBxC mm	h kg	0 N°	1 N°
450x300x150	40,0	1600 104	1601 104
600x400x200	90,0	1600 105	1601 105

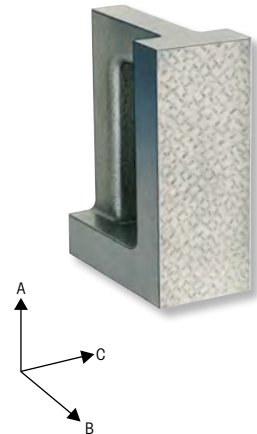

No. 1600 101

## Mess- und Anreißkamin aus Spezialguss mit Spannlöchern



- ▶ DIN 875 / DIN 876
- ▶ Standfläche und 3 Seitenflächen bearbeitet
- ▶ 1 Seitenfläche offen
- ▶ Lieferung einzeln verpackt

**1595 1.. :**  
Güte 0 (feinst geschliffen)

**1596 1.. :**  
Güte 0 (feinst geschliffen) mit Anschlag

**1597 1.. :**  
Güte 1 (geschliffen)

**1598 1.. :**  
Güte 1 (geschliffen) mit Anschlag

! Paarweise Bearbeitung auf Anfrage.

AxBxC mm	h kg	// mm	0 N°	0 N°	// mm	1 N°	1 N°
300x200x130	20,0	0,006	1595 101	1596 101	0,012	1597 101	1598 101
500x200x150	30,0	0,008	1595 102	1596 102	0,016	1597 102	1598 102
700x200x150	40,0	0,010	1595 103	1596 103	0,020	1597 103	1598 103
1000x300x200	80,0	0,012	1595 104	1596 104	0,024	1597 104	1598 104

## Measuring and marking-off blocks, special cast iron with clamping holes

- ▶ DIN 875 / DIN 876
- ▶ Machined base and 3 side faces
- ▶ 1 open side face
- ▶ Delivered in individual packages

**1595 1.. :**  
Grade 0 (fine grinded)

**1596 1.. :**  
Grade 0 (fine grinded) with stop

**1597 1.. :**  
Grade 1 (grinded)

**1598 1.. :**  
Grade 1 (grinded) with stop

! Machining in pairs on request.



No. 1595 103

## Winkelprüfgerät 90°



- ▶ Werksnorm
- ▶ aus Spezialstahl gehärtet
- ▶ Standfläche mit Staubnuten ab 750mm mit Lufttragesystem
- ▶ Dreikantsäule gehärtet
- ▶ Gleitwiderstand am Schuber einstellbar (selbständige Bewegung durch Eigengewicht möglich)
- ▶ Messuhraufnahme Ø 8mm mit Feineinstellung
- ▶ Lieferung inkl. Aufbewahrungskasten, ohne Messuhr

mm	mm	μ	Fuß / Base mm	h kg	N°
0 - 300	440	2	250x90	10,0	1639 101
0 - 500	660	3	250x110	19,0	1639 102

## Squareness testers 90°

- ▶ Works standard
- ▶ Hardened special steel
- ▶ Base with dust grooves, from 750mm with air pad
- ▶ Hardened triangular column
- ▶ Slip resistance adjustable on movable slide (Potential self-movement by dead weight)
- ▶ Dial mounting hole 8 mm with fine adjustment
- ▶ Delivered with storage box, without dial gauge



No. 1639 101



**Messsäule 90°**

**Measuring cylinder 90°**

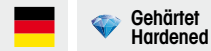

- ▶ Werksnorm
- ▶ aus Spezialstahl gehärtet
- ▶ Standfläche und Mantelfläche bearbeitet
- ▶ mit Handgriff
- ▶ Lieferung einzeln verpackt

- ▶ Works standard
- ▶ Hardened special steel
- ▶ Machined base and jacket surface
- ▶ with handle
- ▶ Delivered in individual packages

**1631 1.. :**

Spezialstahl gehärtet

**1631 1.. :**

Hardened special steel

**1632 1.. :**

Spezialstahl hartverchromt

**1632 1.. :**

Special steel, hard chrome-plated

**1633 1.. :**

Aufbewahrungskasten

**1633 1.. :**

Storage box

! Andere Größen sowie höhere Genauigkeiten auf Anfrage.

! Other sizes and higher accuracy grades on request.



No. 1631 103

ℓ mm	∅ mm	⊥ μ	⚖ kg	Nº	Nº	Nº
160	60	1	3,5	1631 101	1632 101	1633 101
250	80	2	11,0	1631 102	1632 102	1633 102
360	100	2	13,0	1631 103	1632 103	1633 103
500	120	3	24,0	1631 104	1632 104	1633 104
600	140	5	37,0	1631 105	-	1633 105

**Winkelnormale 90°  
Dreieckform aus Naturhartgestein**

**Master squares 90°  
Triangular, granite**



- ▶ DIN 875 / DIN 876
- ▶ 2 Messflächen diamantgeläpft, korrosionsfest und säurebeständig
- ▶ Außenflächen sauber geschliffen
- ▶ ab 500x300mm mit Gewindeeinsätzen für Transportösen
- ▶ Lieferung inkl. Werkskalibrierschein

- ▶ DIN 875 / DIN 876
- ▶ 2 measuring faces, diamond-lapped, corrosion-free and acid-resistant
- ▶ Ground outer faces
- ▶ From 500x300mm with threaded inserts for eyebolts
- ▶ Delivered with works calibration certificate

**1602 1.. :**

Güte 000 - Winkelnormale 90°, Dreieckform

**1602 1.. :**

Grade 000 - Master squares 90°, triangular

**1602 2.. :**

Güte 00 - Winkelnormale 90°, Dreieckform

**1602 2.. :**

Grade 00 - Master squares 90°, triangular

**1602 5.. :**

Aufbewahrungskasten

**1602 5.. :**

Storage box

! Andere Größen und Genauigkeiten auf Anfrage.

! Other sizes and accuracy grades on request.



No. 1602 104

AxBxC mm	⚖ kg	// μ	⊥ μ	ⓐ 000 Nº	// μ	⊥ μ	ⓐ 00 Nº	Nº
400x250x50	8,5	1,5 / 1	1,5	1602 103	2 / 2,5	2,5	1602 203	1602 503
500x300x50	15,0	1,5 / 1	2	1602 104	2,5 / 2	3	1602 204	1602 504
600x400x70	28,0	1,5 / 1,5	2	1602 105	2,5 / 2	3	1602 205	1602 505
800x600x90	69,0	2 / 1,5	2,5	1602 107	3 / 2,5	3,5	1602 207	1602 507
1000x600x120	130,0	2 / 1,5	3	1602 108	3,5 / 2,5	4	1602 208	1602 508
1500x1000x160	380,0	2,5 / 2	4	1602 110	4 / 3,5	5	1602 210	1602 510

1  
2  
3  
4  
5  
6  
7  
8  
9  
10  
11  
12  
13  
14  
15

**Winkelnormale 90°  
Rechteckform aus Naturhartgestein**

**Master square 90°  
Rectangular, granite**



- ▶ DIN 875 / DIN 876
- ▶ Messfläche diamantgeläppt, korrosionsfest und säurebeständig
- ▶ Außenflächen sauber geschliffen
- ▶ mit Gewindeeinsätzen für Transportösen
- ▶ Lieferung inkl. Werkskalibrierschein

- ▶ DIN 875 / DIN 876
- ▶ Measuring faces, diamond-lapped, corrosion-free and acid-resistant
- ▶ Ground outer faces
- ▶ With threaded inserts for eyebolts
- ▶ Delivered with works calibration certificate

**1603 1.. :**  
Güte 000 / 4-seitig bearbeitet

**1603 1.. :**  
Grade 000 / 4-sides machined

**1603 2.. :**  
Güte 00 / 4-seitig bearbeitet

**1603 2.. :**  
Grade 00 / 4-sides machined

**1603 7.. :**  
Güte 000 / 6-seitig bearbeitet

**1603 7.. :**  
Grade 000 / 6-sides machined

**1603 8.. :**  
Güte 00 / 6-seitig bearbeitet

**1603 8.. :**  
Grade 00 / 6-sides machined

**1603 5.. / 1603 9.. :**  
Aufbewahrungskasten

**1603 5.. / 1603 9.. :**  
Storage box

No. 1603 103



No. 1603 705



No. 1603 109

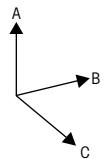

AxBxC mm	h ,0kg	// μ	⊥ μ	000 Nº	// μ	⊥ μ	00 Nº	Nº
Rechteckform, Winkelplatte / Rectangular design								
300x200x50	8,0	2,5 / 2	1,5	1603 101	3 / 2,5	2,5	1603 201	1603 501
400x250x60	17,0	2,5 / 2,5	1,5	1603 102	3,5 / 3	2,5	1603 202	1603 502
400x400x60	23,0	2,5	2,5	1603 103	3,5	2,5	1603 203	1603 503
500x500x70	37,0	3	2	1603 104	4	3	1603 204	1603 504
600x300x80	37,0	3 / 2,5	2	1603 105	4,5 / 3	3	1603 205	1603 505
600x600x80	68,0	3	2	1603 106	4,5	3	1603 206	1603 506
800x400x100	75,0	3,5 / 2,5	2,5	1603 107	5 / 3,5	3,5	1603 207	1603 507
800x800x100	150,0	3,5	2,5	1603 108	5	3,5	1603 208	1603 508
1000x500x120	130,0	4 / 3	3	1603 109	6 / 4	4	1603 209	1603 509
1000x1000x120	250,0	4	3	1603 110	6	4	1603 210	1603 510
Kaminform, Säule / Column design								
300x150x150	20,0	2 / 2,5	1 / 1,5	1603 701	2,5 / 3	2 / 2,5	1603 801	1603 901
500x250x250	90,0	2,5 / 3	1,5 / 2	1603 702	2,5 / 4	2,5 / 3	1603 802	1603 902
1000x300x300	260,0	2,5 / 4	1,5 / 3	1603 703	3 / 6	2,5 / 4	1603 803	1603 903
Würfelform / Cube design								
150x150x150	10,0	2	1	1603 704	2,5	2	1603 804	1603 904
300x300x300	78,0	2,5	1,5	1603 705	3	2,5	1603 805	1603 905
400x400x400	185,0	2,5	1,5	1603 706	3,5	2,5	1603 806	1603 906
500x500x500	368,0	3	2	1603 707	4	3	1603 807	1603 907
750x750x750	1230,0	3,5	2,5	1603 708	5	3,5	1603 808	1603 908
1000x1000x1000	2900,0	4	3	1603 709	6	4	1603 809	1603 909

**Magnet- Mess- und Spannprismen**

**Magnetic V blocks**



- ▶ Werksnorm
- ▶ Genauigkeit 0,008mm
- ▶ Spezialstahl geschliffen
- ▶ 2-seitig bearbeitet
- ▶ 2 prismatische Einschnitte 108°
- ▶ Magnet ein- ausschaltbar
- ▶ Lieferung einzeln oder paarweise verpackt

- ▶ Works standard
- ▶ Accuracy 0.008 mm
- ▶ Ground special steel
- ▶ 2-side machining
- ▶ 2 V grooves 108°
- ▶ Switchable magnet
- ▶ Delivered in packages (single or pair)

**1656 5.. :**  
Magnet- Mess- und Spannprismen

**1656 5.. :**  
Magnetic V blocks

**1658 1.. :**  
Holzetui für 1 Stück

**1658 1.. :**  
Wooden box for 1 piece



No. 1656 501

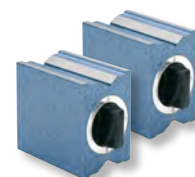

No. 1656 501pa

h mm	Werkstück / Workpiece Ø mm	N N	h kg	Stück / Single Nº	Nº	h kg	Paar / Pair Nº
70x45x65	6 - 35	300/600	1,4	1656 501	1658 103	2,8	1656 501pa

## Magnet- Mess- und Spannprismen

## Magnetic V blocks



- ▶ Werksnorm
- ▶ Genauigkeit 0,004mm
- ▶ 5-seitig bearbeitet
- ▶ 2 prismatische Einschnitte 90°
- ▶ Magnet ein- ausschaltbar
- ▶ Lieferung einzeln oder paarweise verpackt

- ▶ Works standard
- ▶ Accuracy 0.004 mm
- ▶ 5-side machining
- ▶ 2 V grooves 90°
- ▶ Switchable magnet
- ▶ Delivered in packages (single or pair)

**1656 1.. :**  
Spezialstahl Standard

**1656 1.. :**  
Special steel standard

**1657 1.. :**  
Spezialstahl gehärtet

**1657 1.. :**  
Hardened special steel

**1658 1.. :**  
Holzetui für 1 Stück

**1658 1.. :**  
Wooden box for 1 piece

! Höhere Genauigkeit auf Anfrage.

! Higher accuracy grades on request.

l <sub>z</sub> mm	Werkstück Workpiece Ø mm	N	kg	Stück Single Nº	Nº	kg	Paar Pair Nº
80x67x96	6 – 66	400/900	2,9	1656 101	1658 101	5,8	1656 101pa
100x70x96	6 – 72	400/1200	3,8	1656 102	1658 102	7,4	1656 102pa
80x67x96	6 – 66	400/900	2,9	1657 101	1658 101	5,8	1657 101pa
100x70x96	6 – 72	400/1200	3,8	1657 102	1658 102	7,4	1657 102pa



## Prismen mit Spannbügel

## Double V blocks and clamps



- ▶ Werksnorm
- ▶ Genauigkeit 0,004mm
- ▶ Spezialstahl gehärtet
- ▶ allseitig bearbeitet
- ▶ 2 prismatische Einschnitte 90°
- ▶ Lieferung einzeln oder paarweise verpackt

- ▶ Works standard
- ▶ Accuracy 0.004 mm
- ▶ Hardened special steel
- ▶ All-side machining
- ▶ 2 V grooves 90°
- ▶ Delivered in a package (single or pair)

**1640 1..**  
Standard, 2 Auflageflächen

**1640 1..**  
Standard, 2 supporting surfaces

**1641 1.. :**  
seitlich umglegbar, 4 Auflageflächen

**1641 1.. :**  
Tilted on side, 4 supporting surfaces

**1644 1.. / 1644 2.. :**  
Holzetui für 1 Paar

**1644 1.. / 1644 2.. :**  
Wooden box for 1 pair

! Höhere Genauigkeit auf Anfrage.

! Higher accuracy grades on request.

l <sub>z</sub> mm	Werkstück Workpiece Ø mm	kg	Stück Single Nº	kg	Paar Pair Nº	Nº
50x40x40	5 – 30	0,5	1640 101	1,0	1640 101pa	1644 101
75x55x55	5 – 50	1,5	1640 102	3,0	1640 102pa	1644 102
100x75x75	7 – 70	3,5	1640 103	7,0	1640 103pa	1644 103
60x58x40	5 – 30	0,7	1641 101	1,4	1641 101pa	1644 201
75x70x54	5 – 50	1,6	1641 102	3,2	1641 102pa	1644 202
100x96x75	7 – 70	3,7	1641 103	7,4	1641 103pa	1644 203



## Prismen mit Spannbügel

## Double V blocks and clamps



- ▶ Werksnorm
- ▶ Genauigkeit 0,004mm
- ▶ rostfreier Stahl gehärtet
- ▶ allseitig bearbeitet
- ▶ 2 prismatische Einschnitte 90°
- ▶ Lieferung einzeln oder paarweise verpackt

- ▶ Works standard
- ▶ Accuracy 0.004 mm
- ▶ Hardened stainless steel
- ▶ All-side machining
- ▶ 2 V grooves 90°
- ▶ Delivered in packages (single or pair)

**1642 1.. :**  
Standard, 2 Auflageflächen

**1642 1.. :**  
Standard, 2 supporting surfaces

**1644 1.. :**  
Holzetui für 1 Paar

**1644 1.. :**  
Wooden box for 1 pair

No. 1642 101pa



No. 1642 101



! Höhere Genauigkeit auf Anfrage.

! Higher accuracy grades on request.

l <sub>z</sub> mm	Werkstück / Workpiece Ø mm	kg	Stück / Single N <sup>o</sup>	kg	Paar / Pair N <sup>o</sup>	N <sup>o</sup>
50x40x40	5 – 30	0,5	1642 101	1,0	1642 101pa	1644 101
75x55x55	5 – 50	1,5	1642 102	3,0	1642 102pa	1644 102
100x75x75	7 – 70	3,5	1642 103	7,0	1642 103pa	1644 103

## Prismen-Paare aus Stahl

## V-block pairs, special steel



- ▶ Werksnorm
- ▶ Genauigkeit 0,004mm
- ▶ Spezialstahl gehärtet
- ▶ allseitig bearbeitet
- ▶ 1 prismatischer Einschnitt 90°
- ▶ Lieferung paarweise verpackt

- ▶ Works standard
- ▶ Accuracy 0.004 mm
- ▶ Hardened special steel
- ▶ All-side machining
- ▶ 1 V groove 90°
- ▶ Delivered in a package (pair)

! Höhere Genauigkeit sowie Doppel- oder Dreifachprismen auf Anfrage.

! Higher accuracy grades and double or triple V blocks on request.



No. 1648 102

l <sub>z</sub> mm	Werkstück / Workpiece Ø mm	kg	Paar / Pair N <sup>o</sup>	l <sub>z</sub> mm	Werkstück / Workpiece Ø mm	kg	Paar / Pair N <sup>o</sup>
75x35x30	5 – 40	1,0	1648 101	200x65x55	5 – 75	8,5	1648 104
100x47x40	5 – 55	2,2	1648 102	250x85x70	5 – 100	17,0	1648 105
150x55x45	5 – 60	4,4	1648 103				

## Prismen-Paare aus Spezialguss

## V block pairs, special cast iron



- ▶ Werksnorm
- ▶ Standfläche und Prisma bearbeitet
- ▶ 1 prismatischer Einschnitt 90°
- ▶ Lieferung paarweise verpackt

- ▶ Works standard
- ▶ Machined base and V block
- ▶ 1 V groove 90°
- ▶ Delivered in a package (pair)

**1645 1.. :**  
Güte 0 / Gen. 0,008mm

**1645 1.. :**  
Grade 0 / Acc. 0.008 mm

**1646 1.. :**  
Güte 1 / Gen. 0,016mm

**1646 1.. :**  
Grade 1 / Acc. 0.016 mm

**1647 1.. :**  
Güte 3 / Gen. 0,064mm

**1647 1.. :**  
Grade 3 / Acc. 0.064 mm

! Höhere Genauigkeit sowie Doppel- oder Dreifachprismen auf Anfrage.

! Higher accuracy grades and double or triple V blocks on request



No. 1646 102

l <sub>z</sub> mm	Werkstück / Workpiece Ø mm	kg	0 N <sup>o</sup>	1 N <sup>o</sup>	3 N <sup>o</sup>
100x40x30	6 – 40	2,0	1645 102	1646 102	1647 102
150x50x40	8 – 50	4,0	1645 103	1646 103	1647 103
200x70x50	8 – 70	8,0	1645 104	1646 104	1647 104
250x85x60	12 – 85	13,0	1645 105	1646 105	1647 105
300x100x70	12 – 100	18,0	1645 106	1646 106	1647 106

**Winkelprismen verstellbar**

**V blocks, adjustable**



- ▶ Werksnorm
- ▶ Schwenkbereich 60°
- ▶ auf beliebiger Position klemmbar
- ▶ Spezialstahl gehärtet
- ▶ 1 prismatischer Einschnitt 90°
- ▶ Lieferung einzeln verpackt

- ▶ Works standard
- ▶ Pivoting range 60°
- ▶ Clampable at any position
- ▶ Hardened special steel
- ▶ 1 V groove 90°
- ▶ Delivered in individual packages

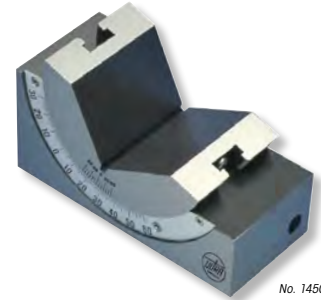

No. 1450 102

l <sub>1</sub> mm	Werkstück / Workpiece Ø mm	kg	Nº
75x25x36	5 – 30	0,4	1450 101
102x30x49	5 – 50	0,8	1450 102
102x46x49	5 – 60	1,3	1450 103

**Parallelstück-Paare aus Spezialguss**

**Parallel V block pairs, special cast iron**



- ▶ Werksnorm
- ▶ 4-seitig bearbeitet
- ▶ 4 prismatische Einschnitte 90°
- ▶ Lieferung paarweise verpackt

- ▶ Works standard
- ▶ 4-side machining
- ▶ 4 V grooves 90°
- ▶ Delivered in a package (pair)

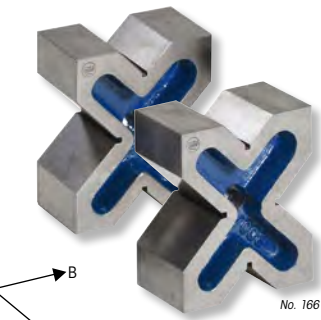

No. 1661 102

<b>1660 1.. :</b> Güte 0 / Gen. 0,008mm	<b>1660 1.. :</b> Grade 0 / Acc. 0.008 mm
--	--

<b>1661 1.. :</b> Güte 1 / Gen. 0,016mm	<b>1661 1.. :</b> Grade 1 / Acc. 0.016 mm
--	--

! 6-seitig bearbeitete Ausführungen auf Anfrage.

! Versions with 6-side machining on request.

A x B x C mm	Werkstück / Workpiece Ø mm	kg	0 Nº	1 Nº	A x B x C mm	Werkstück / Workpiece Ø mm	kg	0 Nº	1 Nº
120x100x60	8 – 90	8,0	1660 102	1661 102	200x170x90	12 – 180	20,0	1660 104	1661 104
150x130x75	10 – 120	13,0	1660 103	1661 103	300x200x90	14 – 220	40,0	1660 105	1661 105

**Prismen-Paare aus Spezialguss für große Durchmesser**

**V-block pairs, special cast iron for large diameters**



- ▶ Werksnorm
- ▶ Standfläche und Prisma bearbeitet
- ▶ 1 prismatischer Einschnitt 90°
- ▶ Lieferung paarweise verpackt

- ▶ Works standard
- ▶ Machined base and V block
- ▶ 1 V groove 90°
- ▶ Delivered in a package (pair)



No. 1650 201

<b>1650 1.. :</b> Güte 0 / 0,008mm	<b>1650 1.. :</b> Grade 0 / Acc. 0.008 mm
---------------------------------------	--

<b>1650 2.. :</b> Güte 0 / Gen. 0,008mm mit Stahlauflage gehärtet	<b>1650 2.. :</b> Grade 0 / Acc. 0.008 mm with hardened steel surface
--	--

<b>1651 1.. :</b> Güte 1 / Gen. 0,016mm	<b>1651 1.. :</b> Grade 1 / Acc. 0.016 mm
--	--

<b>1651 2.. :</b> Güte 1 / Gen. 0,016mm mit Stahlauflage gehärtet	<b>1651 2.. :</b> Grade 1 / Acc. 0.016 mm with hardened steel surface
--	--

<b>1652 1.. :</b> Güte 3 / Gen. 0,064mm	<b>1652 1.. :</b> Grade 3 / Acc. 0.064 mm
--	--

<b>1652 2.. :</b> Güte 3 / Gen. 0,064mm mit Stahlauflage gehärtet	<b>1652 2.. :</b> Grade 3 / Acc. 0.064 mm with hardened steel surface
--	--

! Ausführungen mit Nutsteinen und Klemmung auf Anfrage.

! Versions with T nuts and clamping on request.

A x B x C mm	Werkstück / Workpiece Ø mm	kg	0 Nº	0 Nº	1 Nº	1 Nº	3 Nº	3 Nº
120x270x180	100-200	45,0	1650 101	1650 201	1651 101	1651 201	1652 101	1652 201
180x360x220	200-300	110,0	1650 102	1650 202	1651 102	1651 202	1652 102	1652 202
240x500x300	300-450	240,0	1650 103	1650 203	1651 103	1651 203	1652 103	1652 203
300x650x380	450-600	480,0	1650 104	1650 204	1651 104	1651 204	1652 104	1652 204

## Parallelunterlagen-Sätze

## Parallel support sets



**Gehärtet  
Hardened**

- ▶ DIN 6346
- ▶ aus Spezialstahl gehärtet
- ▶ 4 Längsflächen paarweise planparallel bearbeitet
- ▶ Nennmaßtoleranz der Höhe und Breite  $\pm 0,02$ mm
- ▶ Lieferung im Holzetui

- ▶ DIN 6346
- ▶ Hardened special steel
- ▶ 4 longitudinal surfaces plane parallel-machined in pairs
- ▶ Nominal size tolerance of height and width  $\pm 0.02$  mm
- ▶ Delivered in wooden box

! Einzelne Paare auf Anfrage.

! Individual pairs on request.

Paare Pair	mm	mm		kg	Nº
9	2,5 – 25	8x2,5 / 63 10x3,2 / 63 12x4 / 63 16x5 / 63 20x6,3 / 63	12x4 / 100 16x5 / 100 20x6,3 / 100 25x8 / 100	1,2	1569 130
5	4 – 32	12x4 / 100 16x5 / 100 20x6,3 / 100 25x8 / 100 32x10 / 100		1,4	1569 230
7	4 – 40	12x4 / 100 16x5 / 100 20x6,3 / 100 25x8 / 100	25x8 / 160 32x10 / 160 40x12 / 160	3,5	1569 330
4	8 – 50	25x8 / 160 32x10 / 160 40x12 / 160 50x16 / 160		5,0	1569 430
5	8 – 63	25x8 / 100 32x10 / 100 40x12 / 100	50x16 / 160 63x20 / 160	7,0	1569 530
3	20 – 100	63x20 / 250 80x25 / 250 100x32 / 250		27,0	1569 630



No. 1569 130



No. 1569 230



No. 1569 530

## Parallelunterlagen-Sätze

## Parallel support sets



**TOP**



**Gehärtet  
Hardened**

- ▶ Werksnorm
- ▶ aus Spezialstahl gehärtet
- ▶ 4 Längsflächen paarweise planparallel bearbeitet
- ▶ Nennmaßtoleranz der Höhe und Breite  $\pm 0,01$ mm
- ▶ durch verschiedene Kombinationen können Nennmaße in 1mm Stufung gebildet werden (ausgenommen Nennmaß 9mm bei Länge 125mm und 150mm)
- ▶ Lieferung im Holzständer stehend

- ▶ Works standard
- ▶ Hardened special steel
- ▶ 4 longitudinal surfaces plane parallel-machined in pairs
- ▶ Nominal size tolerance of height and width  $\pm 0.01$  mm
- ▶ Nominal sizes can be attained in 1 mm step through several combinations (Excepting 9 mm nominal size in lengths 125 mm and 150 mm)
- ▶ Delivered upright in wooden support

! Einzelne Paare sowie höhere Genauigkeit auf Anfrage.

! Individual pairs and higher accuracy grades on request.

Paare Pair	mm	mm	mm	kg	Nº	
20	2 – 24	2x5/ 2x10/ 2x15/ 2x20/ 3x6/ 3x11/ 3x16/ 3x21/ 4x7/ 4x12 4x17/ 4x22/ 5x8/ 5x13/ 5x18/ 5x23/ 6x9/ 6x14/ 6x19/ 6x24		100	2,8	1568 130
24	8 – 42	8x11/ 8x16/ 8x21/ 8x26/ 8x31/ 8x36/ 10x13/ 10x18/ 10x23 10x28/ 10x33/ 10x38/ 12x15/ 12x20/ 12x25/ 12x30 12x35/ 12x40/ 14x17/ 14x22/ 14x27/ 14x32/ 14x37/ 14x42		125	14,8	1568 230
24	8 – 42	8x11/ 8x16/ 8x21/ 8x26/ 8x31/ 8x36/ 10x13/ 10x18/ 10x23 10x28/ 10x33/ 10x38/ 12x15/ 12x20/ 12x25/ 12x30/ 12x35 12x40/ 14x17/ 14x22/ 14x27/ 14x32/ 14x37/ 14x42		150	18,0	1568 330

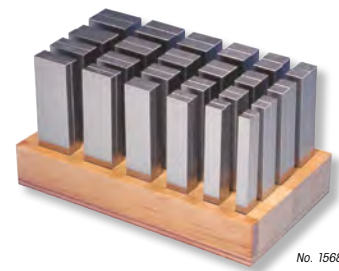

No. 1568 230

## Parallelunterlagen-Sätze

## Parallel support sets



**TOP**



**Gehärtet  
Hardened**

- ▶ Werksnorm
- ▶ aus Spezialstahl gehärtet
- ▶ 4 Längsflächen paarweise planparallel bearbeitet
- ▶ Nennmaßtoleranz der Höhe  $\pm 0,01$ , Breite  $\pm 0,02$  mm
- ▶ Lieferung in Holzetui

! Einzelne Paare, größere Abmessungen sowie Ausführungen aus Spezialguss oder Hartgestein auf Anfrage.

- ▶ Works standard
- ▶ Hardened special steel
- ▶ 4 longitudinal surfaces plane parallel-machined in pairs
- ▶ Nominal size tolerance of height  $\pm 0,01$ , width  $\pm 0,02$  mm
- ▶ Delivered in wooden box

! Individual pairs, larger dimensions and special cast-iron or granite versions on request.



No. 1579 120

Paare Pair	mm	mm	kg	// mm	Nº
14	14/16/18/20/22/24/26 28/30/32/35/40/45/50	150 x 10	12,0	$\pm 0,002$	<b>1579 120</b>
				$\pm 0,005$	<b>1579 220</b>
				$\pm 0,01$	<b>1579 320</b>

## Abrichtlineale aus Spezialguss

## Straightedges, special cast iron



- ▶ DIN 876
- ▶ mit Löchern zur Gewichtserleichterung
- ▶ Lieferung einzeln verpackt

**1666 1.. :**  
Güte 0

**1667 1.. :**  
Güte 1

**1668 1.. :**  
Holzschutzdeckel

! Andere Größen sowie höhere Genauigkeiten auf Anfrage.

- ▶ DIN 876
- ▶ With lightening holes
- ▶ Delivered in individual packages

**1666 1.. :**  
Grade 0

**1667 1.. :**  
Grade 1

**1668 1.. :**  
Wooden protective cover

! Other sizes and higher accuracy grades on request.

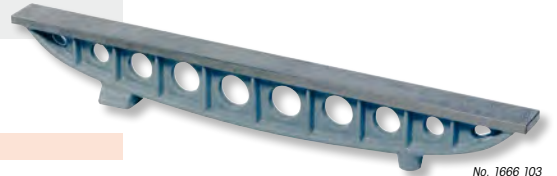

No. 1666 103

L mm	h kg	∠ μ	GG 0 Nº	∠ μ	GG 1 Nº	Nº	L mm	h kg	∠ μ	GG 0 Nº	∠ μ	GG 1 Nº	Nº
500x40	5,0	6	<b>1666 101</b>	15	<b>1667 101</b>	<b>1668 101</b>	2000x70	74,0	12	<b>1666 105</b>	30	<b>1667 105</b>	<b>1668 105</b>
750x45	11,0	7	<b>1666 102</b>	18	<b>1667 102</b>	<b>1668 102</b>	2500x80	149,0	14	<b>1666 106</b>	35	<b>1667 106</b>	<b>1668 106</b>
1000x50	17,0	8	<b>1666 103</b>	20	<b>1667 103</b>	<b>1668 103</b>	3000x90	189,0	16	<b>1666 107</b>	40	<b>1667 107</b>	<b>1668 107</b>
1500x60	50,0	10	<b>1666 104</b>	25	<b>1667 104</b>	<b>1668 104</b>							

## Messbalken aus Spezialguss

## Straightedges, special cast iron



- ▶ DIN 876
- ▶ mit Löchern zur Gewichtserleichterung
- ▶ 2 Handgriffe
- ▶ 2 Messflächen planparallel bearbeitet
- ▶ Lieferung einzeln verpackt

**1672 1.. :**  
Güte 0

**1673 1.. :**  
Güte 1

**1668 5.. :**  
Aufbewahrungskasten

! Andere Größen sowie höhere Genauigkeiten auf Anfrage.

- ▶ DIN 876
- ▶ With lightening holes
- ▶ 2 handles
- ▶ 2 longitudinal surfaces plane parallel-machined
- ▶ Delivered in individual packages

**1672 1.. :**  
Grade 0

**1673 1.. :**  
Grade 1

**1668 5.. :**  
Storage box

! Other sizes and higher accuracy grades on request.

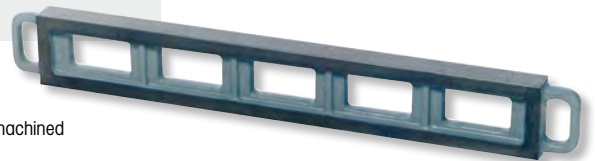

No. 1672 103

L mm	h kg	∠ μ	GG 0 Nº	∠ μ	GG 1 Nº	Nº
500x50x110	5,0	6	<b>1672 101</b>	15	<b>1673 101</b>	<b>1668 501</b>
750x50x110	15,0	7	<b>1672 102</b>	18	<b>1673 102</b>	<b>1668 502</b>
1000x56x140	25,0	8	<b>1672 103</b>	20	<b>1673 103</b>	<b>1668 503</b>
1500x70x175	65,0	10	<b>1672 104</b>	20	<b>1673 104</b>	<b>1668 504</b>
2000x80x200	90,0	12	<b>1672 105</b>	30	<b>1673 105</b>	<b>1668 505</b>

## Messbalken aus Naturhartgestein

## Straightedges, granite



- ▶ DIN 876
- ▶ Außenflächen sauber geschliffen
- ▶ 2 Messflächen planparallel diamantgeläppt
- ▶ 2 Handgriffe
- ▶ Lieferung einzeln verpackt inkl. Werkskalibrierschein

- ▶ DIN 876
- ▶ Ground outer surfaces
- ▶ 2 measuring faces plane parallel diamond lapped
- ▶ 2 handles
- ▶ Delivered in individual packages incl. works calibration certificate



No. 1669 102

**1669 1.. :**  
Güte 000

**1669 1.. :**  
Grade 000

**1670 1.. :**  
Güte 00

**1670 1.. :**  
Grade 00

**1668 9.. :**  
Aufbewahrungskasten

**1668 9.. :**  
Storage box

! Andere Größen sowie höhere Genauigkeiten auf Anfrage.

! Other sizes and higher accuracy grades on request.

∓ mm	± kg	// μ	000 Nº	// μ	00 Nº	Nº
500x50x80	6,0	3	1669 101	4	1670 101	1668 901
750x60x120	16,0	3,5	1669 102	5	1670 102	1668 902
1000x60x150	26,0	4	1669 103	6	1670 103	1668 903
1250x70x190	48,0	4,5	1669 104	6,8	1670 104	1668 904
1500x80x220	77,0	5	1669 105	8	1670 105	1668 905
2000x90x260	135,0	6	1669 107	10	1670 107	1668 907



# 9

## Lineale

Straightedges

## Maßstäbe

Rules

## Bandmaße

Measuring tapes

## Klein-Lehren

Small gauges

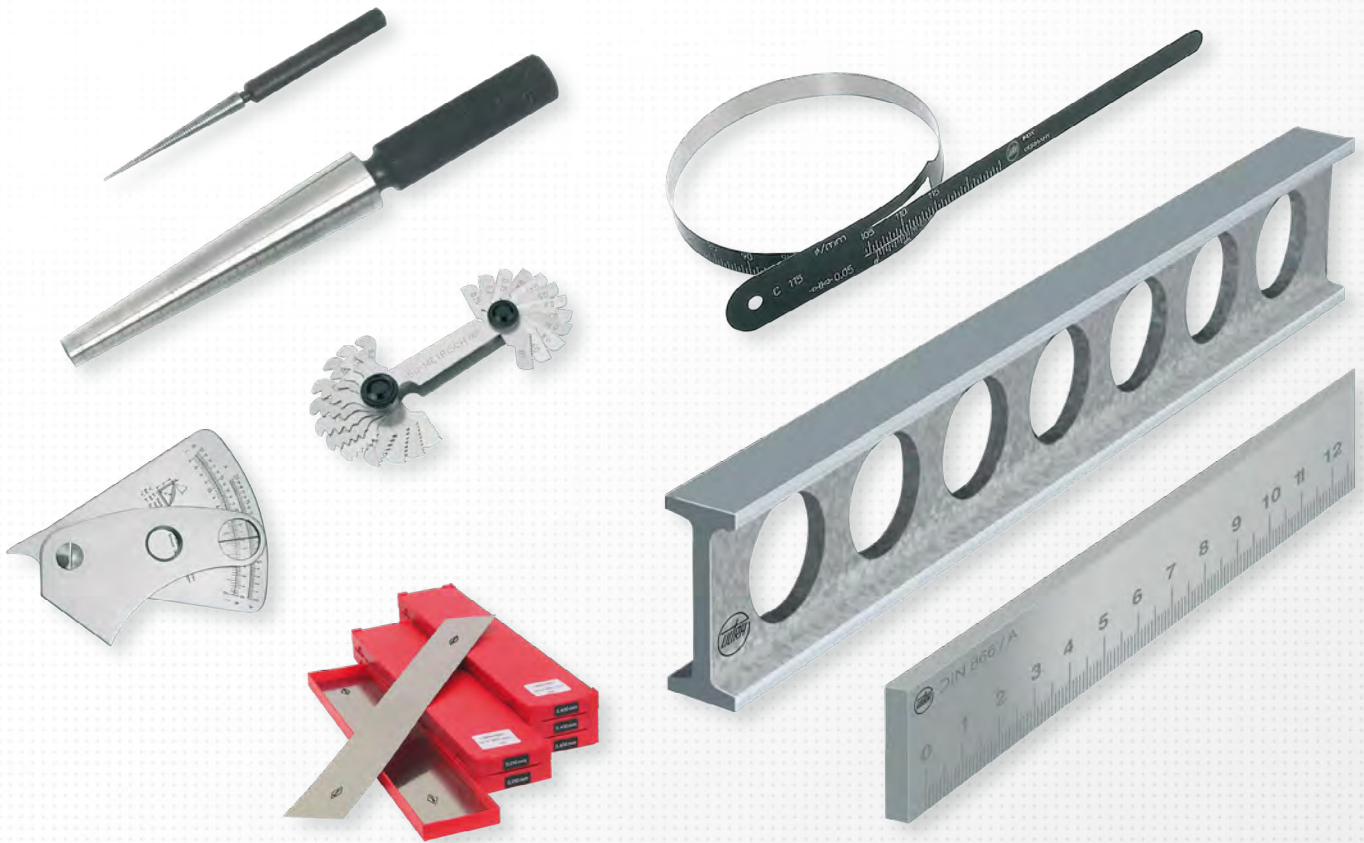

★ **NEW**

Taschen-Rollbandmaße  
Measuring tapes, pocket size

**BMI**



9.11

Rollbandmaße  
Measuring tapes

**BMI**



9.11

Unterlagssfolien  
Shim stock



9.14

Digital-Spaltmessgeräte  
Digital caliper, step gauge



9.18

## ULTRA Flachlineale und Montagelineale aus Aluminium

Aluminiumlineale sind leicht und handlich; ca. 2/3 Gewichtersparnis gegenüber Stahllinealen.  
Eine Hart-Coat Beschichtung sorgt für hohe Verschleißfestigkeit und Korrosionsbeständigkeit.

Schichteigenschaften:

- Schichtstärke ca. 50µ
- Härte 500 – 550HV
- hohe elektrische Isolationswirkung /  $4 \cdot 10^{15} \Omega \text{ mm}^2 / \text{m}$
- geringe Wärmeleitfähigkeit
- gutes Gleitverhalten

### Ebenheitstoleranzen für Lineale nach DIN 874

Die Berechnung erfolgt nach den in der Tabelle angegebenen Formeln (die Toleranzen sind gerundet).

Die nach DIN angegebenen Toleranzen haben nur Gültigkeit, wenn eine Lagerung der Lineale an den optimalen Auflagepunkten gemäß Skizze erfolgt. Für die Parallelität der Messflächen zueinander gelten die doppelten Werte.

Länge / Length a = mm	ⓄⓄ 00 (1 + a/150)µ	ⓄⓄ 0 (2 + a/100)µ	ⓄⓄ 1 (4 + a/60)µ	ⓄⓄ 2 (8 + a/40)µ
300	2	5	-	-
500	4	7	12	21
750	6	9,5	17	27
1000	8	12	21	33
1500	11	17	29	46
2000	14	22	37	58
2500	-	27	46	71
3000	-	32	54	83
4000	-	42	71	108
5000	-	52	87	133
6000	-	62	104	158

## ULTRA aluminium straightedges, flat and assembling

Aluminium straightedges are light and handy; approx. 2/3rd of the weight is saved in comparison to steel straightedges.  
A hard coat provides for high wear and corrosion resistances.

Coat properties:

- Coat thickness approx. 50µ
- Hardness 500 – 550HV
- High electrical insulation /  $4 \cdot 10^{15} \Omega \text{ mm}^2 / \text{m}$
- Minor thermal conductivity
- Good sliding property

### Flatness tolerances for straightedges according to DIN 874

The calculation is done according to the formulas given in the table; the tolerances are rounded off.

The tolerances specified in the table are valid only if the suspension of the straightedges on its bearing points is done according to the drawing. Double values apply for the parallelism of the measuring surfaces to one another.

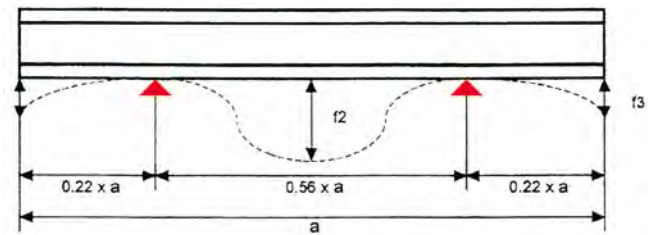

▲ Optimale Auflagepunkte / Bearing points

### Teilungsgenauigkeit und Geradheit von Maßstäben nach DIN 866 Form A und B

Die Geradheit bezieht sich auf die untere Messfläche.

- Form A** – Maßstab beidseitig mit 10mm Schutzenden  
**Form B** – Maßstab links mit 0-Strich beginnend, rechts mit 10mm Schutzende



### Scale accuracy and straightness of rules according to DIN 866, form A and B

The straightness refers to the lower measuring surface.

- Form A** – 10 mm protective ends on both sides of rule  
**Form B** – Rule begins on the left with 0 point; right with 10 mm protective end.

Länge / Length a = mm	Form A		Form B	
	Geradheit Straightness µ	Teilungsgenauigkeit Scale accuracy µ	Geradheit Straightness µ	Teilungsgenauigkeit Scale accuracy µ
500	35	30	70	75
1000	60	40	120	100
1500	85	50	170	125
2000	110	60	220	150
3000	160	80	320	200

### Längentoleranzen

Längentoleranzen von Gliedermaßstäben, Bandmaßen und Rollmaßen nach EG Genauigkeitsklassen.

Länge / Length m	0,5	1	2	3	5	10	15	20	25	30	50
EG I / mm	0,2	0,2	0,3	0,4	0,6	1,1	1,6	2,1	2,6	3,1	5,1
EG II / mm	0,5	0,5	0,7	0,9	1,3	2,3	3,3	4,3	5,3	6,3	10,3
EG III / mm	1	1	1,4	1,8	2,6	4,6	6,6	8,6	10,6	12,6	20,6

### Length tolerances

Length tolerances of folding rules, measuring tapes and roller tapes, are as per EC accuracy classes.

### Sonderskalen und Nonien

Wir liefern jede Art von Sonderskalen und Zifferblätter mit hochgenauer Laserteilung aus Stahl, rostfreiem Stahl, Messing, Aluminium etc. Zur Angebotserstellung bitten wir um Ihre Anfrage mit Zeichnungsunterlagen.

### Special scales and verniers

We supply all types of special scales and dials with highly accurate laser scale, made of steel, stainless steel, brass, aluminium, etc. For the preparation of a quotation, we request you to send us your drawings.



**Sinuslineale aus Stahl**

**Sine bars, steel**



- ▶ Werksnorm, ähnlich DIN 2273
- ▶ Einstellen genauer Winkel nach dem Sinusprinzip mit Endmaßen
- ▶ Spezialstahl gehärtet und geschliffen
- ▶ Werkstückanschlag an einer Stirnseite
- ▶ Lieferung einzeln verpackt

- ▶ Works standard, similar DIN 2273
- ▶ Precise angle adjustment with gauge blocks according to sine principle
- ▶ Hardened and ground special steel
- ▶ Workpiece anvil on the front face
- ▶ Delivered in individual packages



No. 1694 102

**1694 1.. :**  
Sinuslineale

**1694 1.. :**  
Sine bars

**1695 1.. :**  
Holzetui

**1695 1.. :**  
Wooden box



No. 1694 101 + No. 1695 101

Rollenabstand / Roller distance mm	Ⓜ ± mm	⚖ kg	Nº	Nº
100	0,002	0,6	<b>1694 101</b>	<b>1695 101</b>
200	0,002	0,9	<b>1694 102</b>	<b>1695 102</b>
300	0,0025	3,0	<b>1694 103</b>	<b>1695 103</b>
400	0,0025	5,0	<b>1694 104</b>	<b>1695 104</b>
500	0,003	10,0	<b>1694 105</b>	<b>1695 105</b>

**Haarlineale aus Stahl**

**Knife straightedges, steel**

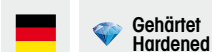

- ▶ DIN 874/00
- ▶ Haarmesskante, Spezialstahl gehärtet
- ▶ mit Handwärmeschutz
- ▶ Lieferung in Kunstledertasche

- ▶ DIN 874/00
- ▶ Knife edge, hardened steel
- ▶ Insulated handle
- ▶ Delivered in imitation leather bag

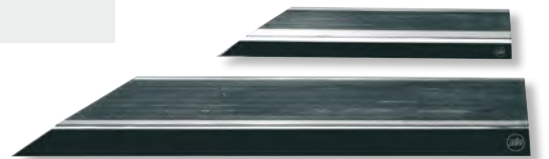

No. 1676 1..

**1676 1.. :**  
blendfrei brüniert

**1676 1.. :**  
Non-glare burnished steel

**1677 1.. :**  
rostfreier Stahl, blendfrei mattiert

**1677 1.. :**  
Non-glare matt finished stainless steel

**1678 1.. :**  
Holzetui

**1678 1.. :**  
Wooden box



No. 1677 102 + No. 1678 102

! Größere Längen auf Anfrage.

! Larger lengths on request

l mm	⚖ kg	Nº	Nº	Nº
75	0,04	<b>1676 101</b>	<b>1677 101</b>	<b>1678 101</b>
100	0,06	<b>1676 102</b>	<b>1677 102</b>	<b>1678 102</b>
125	0,07	<b>1676 103</b>	<b>1677 103</b>	<b>1678 103</b>
150	0,13	<b>1676 104</b>	<b>1677 104</b>	<b>1678 104</b>
200	0,18	<b>1676 105</b>	<b>1677 105</b>	<b>1678 105</b>
300	0,36	<b>1676 107</b>	<b>1677 107</b>	<b>1678 107</b>
400	0,85	<b>1676 108</b>	<b>1677 108</b>	<b>1678 108</b>
500	1,1	<b>1676 109</b>	<b>1677 109</b>	<b>1678 109</b>
600	1,65	<b>1676 110</b>	<b>1677 110</b>	<b>1678 110</b>
750	2,8	<b>1676 111</b>	<b>1677 111</b>	<b>1678 111</b>
1000	4,0	<b>1676 112</b>	<b>1677 112</b>	<b>1678 112</b>

## Kontrolllineale aus Stahl, gehärtet

## Inspection straightedges, hardened steel



**Gehärtet  
Hardened**

- ▶ DIN 874
- ▶ rostfreier Stahl, gehärtet
- ▶ I-förmiger Querschnitt mit 2 Handschlitzten, ab 2000mm
- ▶ Lieferung einzeln verpackt

- ▶ DIN 874
- ▶ Hardened stainless steel
- ▶ I profile with 2 hand slots from 2000mm
- ▶ Delivered in individual packages

**1674 1.. :**  
DIN 874/0

**1674 1.. :**  
DIN 874/0

**1674 2.. :**  
DIN 874/00

**1674 2.. :**  
DIN 874/00

**1688 1.. :**  
Holzetui

**1688 1.. :**  
Wooden box



l- mm	h mm	h kg	0 Nº	00 Nº	Nº
300	40 x 8	0,6	1674 105	1674 205	1688 100
500	50 x 10	1,7	1674 106	1674 206	1688 101
750	50 x 10	3,0	1674 107	1674 207	1688 102
1000	60 x 12	5,0	1674 108	1674 208	1688 103
1500	70 x 14	9,2	1674 109	1674 209	1688 104
2000	80 x 15	12,3	1674 110	1674 210	1688 105

## Flachlineale aus Aluminium

## Flat straightedges, aluminium



**ALUMINIUM**

- ▶ DIN 874
- ▶ I-förmiger Querschnitt
- ▶ geringes Gewicht
- ▶ Hartcoat beschichtet (HC)
- ▶ Lieferung einzeln verpackt

- ▶ DIN 874
- ▶ I profile
- ▶ Light weight
- ▶ Hard coated (HC)
- ▶ Delivered in individual packages

Schichteigenschaften:

- ▶ Schichtstärke ca. 50µ
- ▶ verschleißfest, korrosionsbeständig
- ▶ Härte 500 – 550 HV
- ▶ hohe Isolationswirkung /  $4 \cdot 10^{15} \Omega \text{ mm}^2 / \text{m}$
- ▶ geringe Wärmeleitfähigkeit

Coat properties:

- ▶ Coat thickness approx. 50µ
- ▶ Wear proof and corrosion resistant
- ▶ Hardness 500 – 550 HV
- ▶ High electrical insulation /  $4 \cdot 10^{15} \Omega \text{ mm}^2 / \text{m}$
- ▶ Low heat conductivity

**1685 5.. :**  
DIN 874/0  
ab 1500mm mit 2 Handschlitzten

**1685 5.. :**  
DIN 874/0  
From 1500mm with 2 hand slots

**1687 5.. :**  
DIN 874/1  
ab 1500mm mit 2 Handschlitzten

**1687 5.. :**  
DIN 874/1  
From 1500mm with 2 hand slots

**1690 5.. :**  
DIN 874/2  
ab 2500mm mit 2 Handschlitzten

**1690 5.. :**  
DIN 874/2  
From 2500mm with 2 hand slots

**1688 1.. :**  
Holzetui

**1688 1.. :**  
Wooden box



! Größere Längen auf Anfrage.

! Larger lengths on request.

l- mm	h mm	h kg	0 Nº	1 Nº	2 Nº	Nº
500	60 x 12	0,7	1685 501	1687 501	1690 501	1688 101
1000	60 x 12	1,5	1685 502	1687 502	1690 502	1688 103
1500	100 x 16	4,5	1685 503	1687 503	1690 503	1688 104
2000	100 x 16	6,0	1685 504	1687 504	1690 504	1688 105
2500	100 x 16	7,0	1685 505	1687 505	1690 505	1688 106
3000	150 x 20	16,0	1685 506	1687 506	1690 506	1688 107

## Flachlineale aus Stahl

## Flat straightedge, steel



- ▶ DIN 874
- ▶ Spezialstahl
- ▶ I-förmiger Querschnitt mit 2 Handschlitzen, ab 2000mm
- ▶ Lieferung einzeln verpackt

- ▶ DIN 874
- ▶ Special steel
- ▶ I profile with 2 hand slots from 2000mm
- ▶ Delivered in individual packages

<b>1684 1.. :</b> DIN 874/0 Normalstahl	<b>1684 1.. :</b> DIN 874/0 Normal steel
<b>1685 1.. :</b> DIN 874/0 rostfreier Stahl	<b>1685 1.. :</b> DIN 874/0 Stainless steel
<b>1686 1.. :</b> DIN 874/1 Normalstahl	<b>1686 1.. :</b> DIN 874/1 Normal steel
<b>1687 1.. :</b> DIN 874/1 rostfreier Stahl	<b>1687 1.. :</b> DIN 874/1 Stainless steel
<b>1688 1.. :</b> Holzetui	<b>1688 1.. :</b> Wooden box



! Größere Längen auf Anfrage.

! Larger lengths on request.

l mm	b mm	h mm	0 N°	0 N°	l mm	b mm	h mm	1 N°	1 N°	N°
500	50 x 10	2,0	1684 101	1685 101	500	40 x 8	1,3	1686 101	1687 101	1688 101
1000	60 x 12	5,7	1684 103	1685 103	1000	50 x 10	3,8	1686 103	1687 103	1688 103
1500	70 x 15	9,5	1684 104	1685 104	1500	60 x 12	8,0	1686 104	1687 104	1688 104
2000	80 x 15	12,0	1684 105	1685 105	2000	70 x 15	11,0	1686 105	1687 105	1688 105
2500	100 x 16	21,0	1684 106	1685 106	2500	80 x 15	17,0	1686 106	1687 106	1688 106
3000	120 x 18	36,0	1684 107	1685 107	3000	100 x 16	26,0	1686 107	1687 107	1688 107

## Flachlineale aus Stahl

## Flat straightedge, steel



- ▶ Spezialstahl
- ▶ Lieferung einzeln verpackt

- ▶ Special steel
- ▶ Delivered in individual packages

<b>1689 1.. :</b> DIN 874/2 Normalstahl	<b>1689 1.. :</b> DIN 874/2 Normal steel
<b>1690 1.. :</b> DIN 874/2 rostfreier Stahl	<b>1690 1.. :</b> DIN 874/2 Stainless steel
<b>1691 1.. :</b> Güte 3 Normalstahl	<b>1691 1.. :</b> Quality 3 Normal steel
<b>1692 1.. :</b> Güte 3 rostfreier Stahl	<b>1692 1.. :</b> Quality 3 Stainless steel
<b>1688 1.. :</b> Holzetui	<b>1688 1.. :</b> Wooden box



! Größere Längen auf Anfrage.

! Larger lengths on request.

l mm	b mm	h mm	2 N°	2 N°	l mm	b mm	h mm	3 N°	3 N°	N°
500	30 x 6	0,7	1689 101	1690 101	500	30 x 6	0,7	1691 101	1692 101	1688 101
1000	40 x 8	2,5	1689 102	1690 102	1000	30 x 6	1,4	1691 102	1692 102	1688 103
1500	50 x 10	6,0	1689 103	1690 103	1500	40 x 8	3,7	1691 103	1692 103	1688 104
2000	60 x 12	11,0	1689 104	1690 104	2000	40 x 8	5,0	1691 104	1692 104	1688 105
2500	70 x 15	20,6	1689 105	1690 105	2500	40 x 8	6,2	1691 105	1692 105	1688 106
3000	80 x 15	28,0	1689 106	1690 106	3000	50 x 10	11,5	1691 106	1692 106	1688 107

## Montagelineale aus Aluminium

## Assembling straightedges, aluminium



### ALUMINIUM

- ▶ DIN 874/1
- ▶ I-förmiger Querschnitt
- ▶ schmaler oder starker Querschnitt
- ▶ geringes Gewicht, Löcher zur Gewichtserleichterung
- ▶ Hartcoat beschichtet. (HC)
- ▶ Lieferung einzeln verpackt.

Schichteigenschaften:  
▶ siehe Flachlineale aus Aluminium Seite 9.4

- ▶ DIN 874/1
- ▶ I-profile
- ▶ Narrow or solid profile
- ▶ Light weight with lightening holes
- ▶ Hard coated (HC)
- ▶ Delivered in individual packages

Coat properties:  
▶ See Flat straightedges, aluminium page 9.4

#### 1682 5.. :

schmaler Querschnitt

#### 1682 5.. :

Narrow profile

#### 1682 6.. :

starker Querschnitt

#### 1682 6.. :

Solid profile

#### 1683 ... :

Holzkasten

#### 1683 ... :

Wooden box



l-  mm	mm	kg	0 1 N°	N°
1000	100 x 40	3,3	1682 501	1683 101
1500	100 x 40	5,0	1682 502	1683 102
2000	100 x 40	6,6	1682 503	1683 103
2500	100 x 40	8,3	1682 504	1683 104
3000	100 x 40	9,9	1682 505	1683 105

l-  mm	mm	kg	0 1 N°	N°
1000	160 x 50	5,0	1682 601	1683 201
1500	160 x 50	7,4	1682 602	1683 202
2000	160 x 50	9,8	1682 603	1683 203
2500	160 x 50	12,2	1682 604	1683 204
3000	160 x 50	14,6	1682 605	1683 205
4000	160 x 50	19,5	1682 606	1683 206

## Montagelineale aus Stahl

## Assembling straightedges, steel



### TOP

- ▶ DIN 874
- ▶ I-förmiger Querschnitt
- ▶ schmaler oder starker Querschnitt
- ▶ Löcher zur Gewichtserleichterung
- ▶ Lieferung einzeln verpackt

- ▶ DIN 874
- ▶ I-profile
- ▶ Narrow or solid profile
- ▶ With lightening holes
- ▶ Delivered in individual packages

#### 1681 ... :

DIN 874/0

#### 1681 ... :

DIN 874/0

#### 1682 ... :

DIN 874/1

#### 1682 ... :

DIN 874/1

#### 1683 ... :

Holzkasten

#### 1683 ... :

Wooden box



l-  mm	mm	kg	0 N°	1 N°	N°
schmaler Querschnitt / Narrow profile					
1000	100 x 30	5,0	1681 101	1682 101	1683 101
1500	100 x 30	7,0	1681 102	1682 102	1683 102
2000	120 x 40	15,0	1681 103	1682 103	1683 103
2500	120 x 40	19,0	1681 104	1682 104	1683 104
3000	140 x 40	26,0	1681 105	1682 105	1683 105
4000	140 x 40	36,0	1681 106	1682 106	1683 106
5000	160 x 40	54,0	1681 107	1682 107	1683 107
6000	160 x 40	65,0	1681 108	1682 108	1683 108
starker Querschnitt / Solid profile					
1000	160 x 50	12,0	1681 201	1682 201	1683 201
1500	160 x 50	18,0	1681 202	1682 202	1683 202
2000	160 x 50	24,0	1681 203	1682 203	1683 203
2500	160 x 50	30,0	1681 204	1682 204	1683 204
3000	180 x 60	45,0	1681 205	1682 205	1683 205
4000	180 x 60	60,0	1681 206	1682 206	1683 206
5000	200 x 80	103,0	1681 207	1682 207	1683 207
6000	200 x 80	122,0	1681 208	1682 208	1683 208

## Präzisionsmaßstäbe aus Stahl

## Precision rules, steel



- ▶ DIN 866
- ▶ 1/1mm Teilung
- ▶ allseitig geschliffen
- ▶ Lieferung einzeln verpackt

- ▶ DIN 866
- ▶ 1/1mm graduation
- ▶ All sides ground
- ▶ Delivered in individual packages

**1698 1.. :**  
DIN 866/A Normalstahl  
beiderseitig mit Schutzenden

**1698 1.. :**  
DIN 866/A Normal steel  
with protective ends on both sides

**1698 2.. :**  
DIN 866/A rostfreier Stahl  
beiderseitig mit Schutzenden

**1698 2.. :**  
DIN 866/A Stainless steel  
with protective ends on both sides

**1699 1.. :**  
DIN 866/B Normalstahl  
mit 0-Strich beginnend

**1699 1.. :**  
DIN 866/B Normal steel  
starts with 0 line

**1699 2.. :**  
DIN 866/B rostfreier Stahl  
mit 0-Strich beginnend

**1699 2.. :**  
DIN 866/B Stainless steel  
starts with 0 line

**1688 1.. :**  
Holzetui

**1688 1.. :**  
Wooden box

! Größere Längen auf Anfrage.

! Larger lengths on request.

∟ mm	⊘ mm	⚖ kg	ⓐ A №	ⓐ A №	∟ mm	⊘ mm	⚖ kg	ⓐ B №	ⓐ B №	№
500	30 x 6	0,8	1698 101	1698 201	500	25 x 5	0,5	1699 101	1699 201	1688 101
1000	40 x 8	2,5	1698 102	1698 202	1000	30 x 6	1,5	1699 102	1699 202	1688 103
1500	40 x 8	3,7	1698 103	1698 203	1500	30 x 6	2,1	1699 103	1699 203	1688 104
2000	50 x 10	7,5	1698 104	1698 204	2000	40 x 8	4,8	1699 104	1699 204	1688 105
3000	50 x 10	12,0	1698 105	1698 205	3000	40 x 8	7,5	1699 105	1699 205	1688 107

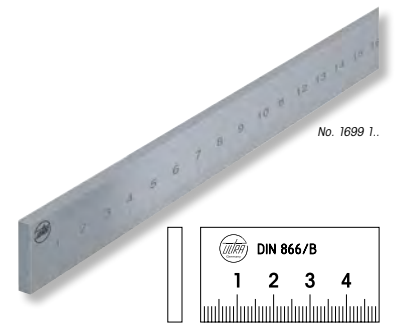
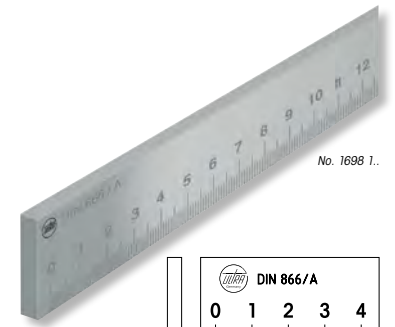

## Maßstäbe mit Facette aus Stahl

## Rules with bevel edge, steel



- ▶ DIN 866/B
- ▶ 1/1mm Teilung
- ▶ mit 0-Strich beginnend
- ▶ Lieferung einzeln verpackt

- ▶ DIN 866/B
- ▶ 1/1mm graduation
- ▶ Starts with 0 line
- ▶ Delivered in individual packages

**1687 2.. :**  
DIN 866/B Normalstahl

**1687 2.. :**  
DIN 866/B Normal steel

**1687 4.. :**  
DIN 866/B rostfreier Stahl

**1687 4.. :**  
DIN 866/B Stainless steel

**1688 1.. :**  
Holzetui

**1688 1.. :**  
Wooden box

! Andere Längen und Ausführungen auf Anfrage

! Other length and versions on request.

∟ mm	⊘ mm	⚖ kg	ⓐ B №	ⓐ B №	№
500	30 x 6	0,6	1687 201	1687 401	1688 101
1000	40 x 8	2,0	1687 203	1687 403	1688 103
2000	50 x 10	5,8	1687 205	1687 405	1688 105
3000	50 x 10	9,0	1687 207	1687 407	1688 107

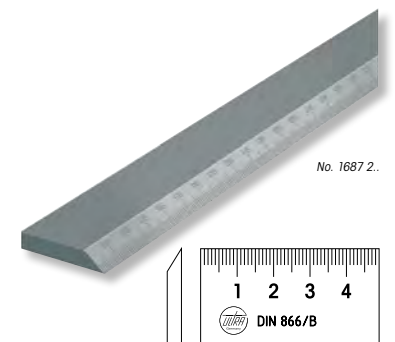

## Lineale mit Facette

## Straightedges with bevel edge



- ▶ Werksnorm
- ▶ Normalstahl verzinkt
- ▶ Lieferung einzeln verpackt

- ▶ Works standard
- ▶ Galvanised normal steel
- ▶ Delivered in individual packages

**5269 2.. :**  
ohne Teilung

**5269 2.. :**  
Without graduation

**5269 3.. :**  
mit 1/1mm-Teilung

**5269 3.. :**  
With 1/1mm graduation

∟ mm	⊘ mm	⚖ kg	Nº	Nº
300	40x5	0,5	5269 201	5269 301
400	40x5	0,65	5269 202	5269 302
500	40x5	0,8	5269 203	5269 303
800	40x5	1,2	5269 204	5269 304
1000	40x5	1,5	5269 205	5269 305
1500	40x5	2,3	5269 206	5269 306
2000	40x5	3,1	5269 207	5269 307



No. 5269 2.

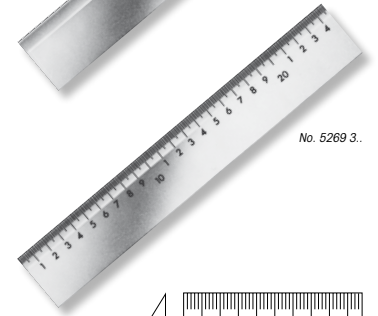

No. 5269 3.

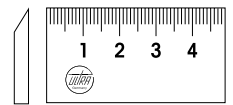

## Maßstäbe mit Facette aus Aluminium

## Rules with bevel edge, aluminium



- ▶ Werksnorm
- ▶ Aluminium eloxiert
- ▶ Tusche-Kante
- ▶ blendfreie 1/1mm-Teilung nach DIN 866/B
- ▶ Lieferung einzeln verpackt

- ▶ Works standard
- ▶ Anodised aluminium
- ▶ Non-smearing edge
- ▶ Non-glare 1/1mm graduation acc. DIN 866/B
- ▶ Delivered in individual packages

∟ mm	⊘ mm	⚖ kg	Nº
300	50x5	0,19	5279 101
600	50x5	0,35	5279 102
1000	50x5	0,58	5279 103

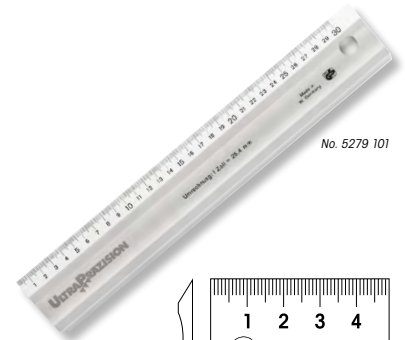

No. 5279 101

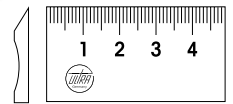

## Bandmaße zum Messen von Außendurchmessern

## Measuring tapes for outer diameters



- ▶ Teilung 1/1mm laserskaliert DIN 866
- ▶ Nonius 0,05mm
- ▶ Lieferung im Karton

- ▶ Laser-scaled 1/1mm graduation DIN 866
- ▶ Vernier 0.05mm
- ▶ Delivered in cardboard box

**5285 3.. :**  
Federbandstahl schwarz beschichtet (Teflon),  
maximaler Kontrast

**5285 3.. :**  
Black coated spring steel (teflon),  
maximum contrast

**5285 4.. :**  
rostfreier Federbandstahl

**5285 4.. :**  
Stainless spring steel

∅ mm	⚖ kg	Nº	Nº
15 - 115	0,05	5285 301	5285 401
100 - 230	0,07	5285 302	5285 402
200 - 330	0,08	5285 303	5285 403
300 - 620	0,11	5285 304	5285 404



No. 5285 301

← Teflon

No. 5285 404



**Umfangbandmaße zum Messen von Außen-Ø und Umfang**

**Circumference tapes for outer Ø and circumference**



- ▶ Teilung 1/1mm laserskaliert DIN 866
- ▶ Querschnitt 16x0,2mm
- ▶ Nonius 0,1mm
- ▶ Lieferung im Karton

- ▶ Laser-scaled 1/1mm graduation DIN 866
- ▶ Cross section 16 x 0.2mm
- ▶ Vernier 0.1mm
- ▶ Delivered in cardboard box

**5285 1.. :**  
Federbandstahl

**5285 1.. :**  
Spring steel

**5285 2.. :**  
rostfreier Federbandstahl

**5285 2.. :**  
Stainless spring steel

**5285 5.. :**  
Federbandstahl schwarz beschichtet (Teflon), maximaler Kontrast

**5285 5.. :**  
Black coated spring steel (teflon), maximum contrast

**I** Größere Ø und Bandbreiten sowie Nonius 0,05mm auf Anfrage.

**I** Larger Ø and tape widths as well as 0.05mm vernier on request.

Ø mm	Umfang / Circumference mm	kg	Nº	Nº	Nº
20 – 300	60 – 950	0,08	<b>5285 101</b>	<b>5285 201</b>	<b>5285 501</b>
300 – 700	940 – 2200	0,11	<b>5285 102</b>	<b>5285 202</b>	<b>5285 502</b>
700 – 1100	2190 – 3460	0,16	<b>5285 103</b>	<b>5285 203</b>	<b>5285 503</b>
1100 – 1500	3450 – 4720	0,19	<b>5285 104</b>	<b>5285 204</b>	<b>5285 504</b>
1500 – 1900	4710 – 5980	0,23	<b>5285 105</b>	<b>5285 205</b>	<b>5285 505</b>
1900 – 2300	5960 – 7230	0,25	<b>5285 106</b>	<b>5285 206</b>	<b>5285 506</b>
2300 – 2700	7220 – 8500	0,29	<b>5285 107</b>	<b>5285 207</b>	<b>5285 507</b>
2700 – 3100	8480 – 9760	0,31	<b>5285 108</b>	<b>5285 208</b>	<b>5285 508</b>
3100 – 3500	9730 – 11010	0,35	<b>5285 109</b>	<b>5285 209</b>	<b>5285 509</b>



**Maßstäbe biegsam**

**Rules, flexible**



- ▶ EG Klasse II
- ▶ rostfreier Federbandstahl
- ▶ Teilung links nach rechts
- ▶ Lieferung einzeln verpackt

- ▶ EC class II
- ▶ Stainless spring steel
- ▶ Left to right graduation
- ▶ Delivered in individual packages

**5295 1.. / 5296 1.. :**  
Teilung A: 1/1mm + 1/1mm

**5295 1.. / 5296 1.. :**  
Graduation A: 1/1mm + 1/1mm

**5295 2.. / 5296 2.. :**  
Teilung B: 1/1mm + 1/2mm

**5295 2.. / 5296 2.. :**  
Graduation B: 1/1mm + 1/2mm

**5295 3.. / 5299 1.. :**  
Teilung C: 1/1mm / 1/2mm + 1/16" / 1/32" / 1/64"

**5295 3.. / 5299 1.. :**  
Graduation C: 1/1mm / 1/2mm + 1/16" / 1/32" / 1/64"

**I** Größere Längen, andere Teilungen, sowie Sonderanfertigungen nach Zeichnung auf Anfrage.

**I** Larger lengths, other graduations and special designs as per drawings on request.

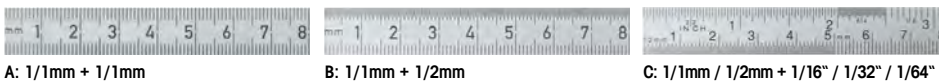

mm	ca. mm	kg	A Nº	B Nº	C Nº
150	13 x 0,5	0,005	<b>5295 101</b>	<b>5295 201</b>	<b>5295 301</b>
200	13 x 0,5	0,006	<b>5295 102</b>	<b>5295 202</b>	<b>5295 302</b>
300	15 x 0,5	0,01	<b>5295 103</b>	<b>5295 203</b>	<b>5295 303</b>
500	20 x 0,5	0,04	<b>5295 104</b>	<b>5295 204</b>	<b>5295 304</b>
1000	20 x 0,5	0,07	<b>5295 105</b>	<b>5295 205</b>	<b>5295 305</b>
1500	20 x 0,5	0,08	<b>5295 106</b>	<b>5295 206</b>	<b>5295 306</b>
2000	20 x 0,5	0,12	<b>5295 107</b>	<b>5295 207</b>	<b>5295 307</b>
300	30 x 1	0,07	<b>5296 101</b>	<b>5296 201</b>	<b>5299 102</b>
500	30 x 1	0,12	<b>5296 102</b>	<b>5296 202</b>	<b>5299 103</b>
1000	30 x 1	0,24	<b>5296 103</b>	<b>5296 203</b>	<b>5299 105</b>
1500	30 x 1	0,36	<b>5296 104</b>	<b>5296 204</b>	-
2000	30 x 1	0,48	<b>5296 105</b>	<b>5296 205</b>	-

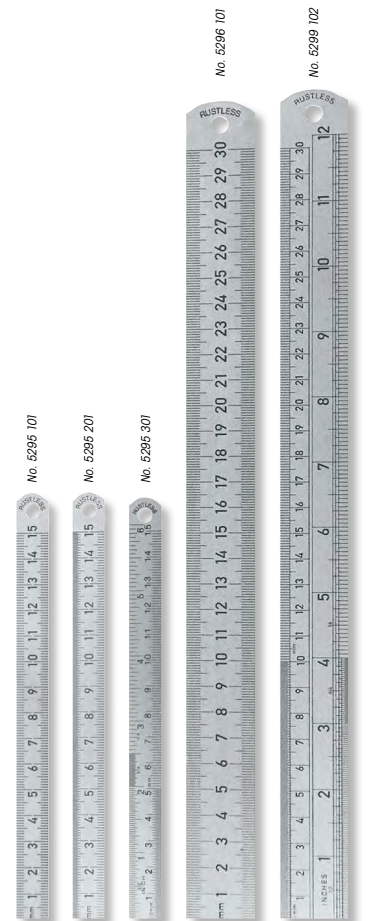

## Teleskopmeter TELEFIX

## Telescopic meters TELEFIX



- ▶ EG Klasse III
- ▶ Aluminium 4-Kantrohr eloxiert
- ▶ teleskopartig ausziehbar
- ▶ Druckfederrasterung
- ▶ mit Dosen- und Längslibelle
- ▶ Ablesung 1/1mm am Sichtfenster
- ▶ Lieferung inkl. Schutztasche

- ▶ EG class III
- ▶ Aluminium square tube anodised
- ▶ Extensible in sections
- ▶ Auto lock off every pole
- ▶ With 2 bubbles
- ▶ Reading 1/1mm on window
- ▶ Delivered in protective bag

**5376 1.. :**

Teleskopmeter TELEFIX

**5376 1.. :**

Telescopic meters TELEFIX

**5378 201 :**

Messdorne (Paar) Ø10x50mm

**5378 201 :**

Measuring pins (pair) Ø10x50mm

**5378 202 :**

Messkeile (Paar) für Diagonalmessung

**5378 202 :**

Sharp end tips (pair) for diagonal measurements

läng m	kg	Nº
0,32 – 1	0,9	<b>5376 101</b>
0,49 – 2	1,2	<b>5376 102</b>
0,66 – 3	1,6	<b>5376 103</b>
0,83 – 4	1,9	<b>5376 104</b>

läng m	kg	Nº
0,99 – 5	2,2	<b>5376 105</b>
1,16 – 6	2,5	<b>5376 106</b>
1,35 – 8	2,8	<b>5376 107</b>
1,63 – 10	3,1	<b>5376 108</b>



## TALMETER Anreißlehre und Rollbandmaße

## TALMETER marking gauge and measuring tapes



- ▶ EG Klasse II
- ▶ Messen und Anreißern
- ▶ Federbandstahl lackiert
- ▶ Außenmaße = schwarze Ziffern
- ▶ Innenmaße = rote Ziffern
- ▶ Bandrücklauf automatisch
- ▶ Stopptaste, Klemmung
- ▶ ABS Gehäuse
- ▶ Lieferung einzeln verpackt

- ▶ EC class II
- ▶ Measuring and marking
- ▶ Lacquered spring steel
- ▶ Outer dimensions = black dial
- ▶ Inner dimensions = red dial
- ▶ Automatic tape return
- ▶ Stop button, clamping
- ▶ ABS housing
- ▶ Delivered in individual packages

**5322 1.. :**

Direktablesung von Ø

**5322 1.. :**

Direct reading for Ø

**5322 2.. :**

Direktablesung von Innenmaßen

**5322 2.. :**

Direct reading for inside measurement

**5322 3.. :**

Ersatzbänder

**5322 3.. :**

Spare tapes

läng m	läng mm	↔	kg	Nº	Nº
2	16	mm/mm	0,11	<b>5322 101</b>	<b>5322 301</b>
3	16	mm/mm	0,16	<b>5322 102</b>	<b>5322 302</b>
6	25	mm/mm	0,42	<b>5322 202</b>	<b>5322 304</b>



## Taschen-Rollbandmaße twoCOMP

## Measuring tapes, pocket size twoCOMP



- ▶ EG Klasse II
- ▶ Federbandstahl lackiert
- ▶ Bandrücklauf automatisch
- ▶ Stoppfaste
- ▶ ABS Gehäuse mit Gummiüberzug
- ▶ rückseitiger Gürtelclip
- ▶ Lieferung einzeln verpackt

- ▶ EC class II
- ▶ Lacquered spring steel
- ▶ Automatic tape return
- ▶ Stop button
- ▶ ABS housing with rubber coating
- ▶ Belt clip on back side
- ▶ Delivered in individual packages

### Bandaufbau:

- 1 - gewölbter, gehärteter Federbandstahl für hohe Standfestigkeit
- 2 - Phosphatschicht als Korrosionsschutz
- 3 - Kunstharzlack, eingebrannt
- 4 - gedruckte Teilung mit roten Dezimeter und Meternvornzahlen, eingebrannt
- 5 - Klarlack als Verschleißschutz, eingebrannt

### Tape structure:

- 1 - Concaved, tempered spring blade steel of high stability
- 2 - Anticorrosive phosphate coating
- 3 - Synthetic resin, stoved
- 4 - Printed graduation with red decimeter and meter figures, stoved
- 5 - Clear varnish to protect against wear, stoved

! Andere Ausführungen sowie Werbeaufdrucke auf Anfrage.

! Other versions and promotional imprints on request.

l m	l mm	Δ	kg	Nº
2	16	mm/mm	0,1	5318 200
3	16	mm/mm	0,11	5318 201
5	19	mm/mm	0,2	5318 203
8	25	mm/mm	0,34	5318 205
10	25	mm/mm	0,4	5318 206

# BMI®

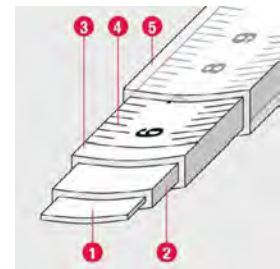

No. 5318 2..

## Rollbandmaße BASIC

## Measuring tapes BASIC



- ▶ Stahlband beschichtet
- ▶ Teilung beginnt 10cm hinter dem Beschlag
- ▶ Handkurbel
- ▶ Lieferung einzeln verpackt

- ▶ Coated steel tapes
- ▶ Graduation starts 10cm from hook
- ▶ Winding handle
- ▶ Delivered in individual packages

### Bandaufbau:

- 1 - Gehärtetes Federband aus Kohlenstoffstahl C 75
- 2 - Phosphatschicht als Korrosionsschutz
- 3 - Weißer Kunstharzlack, eingebrannt
- 4 - Gedruckte Teilung mit roten Meternvornzahlen
- 5 - Klarlack als Verschleißschutz eingebrannt und entspiegelt

### Tape structure:

- 1 - Tempered spring blade steel C 75
- 2 - Anticorrosive phosphate coating
- 3 - White synthetic resin, stoved
- 4 - Printed graduation with red meter figures
- 5 - Clear varnish to protect against wear, stoved

5326 ... :

Kunststoffkapsel rund

5326 ... :

Round plastic case

5332 ... :

Schrägrahmen

5332 ... :

Open frame

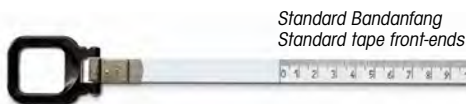

! Andere Ausführungen und Bandanfänge auf Anfrage.

! Other versions and tape front-ends on request.

l m	l mm	Δ	kg	Nº	Nº
20	13	mm	0,75	5326 204	5332 204
30	13	mm	1,1	5326 206	5332 206
50	13	mm	1,4	5326 107	5332 107

# BMI®

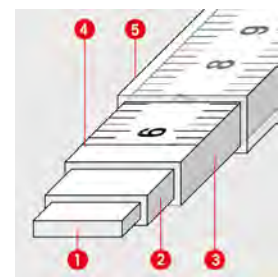

No. 5326 204



No. 5332 206

## Fühlerlehrensätze Ventileinstellehren

## Thickness/Feeler gauge sets Valve setting gauges



- ▶ Stahlblättchen federhart
- ▶ mit Nennmaß beschriftet
- ▶ Bügel mit Feststellschraube
- ▶ Lieferung einzeln verpackt

- ▶ Spring steel leaves
- ▶ Nominal size marked
- ▶ Frame with locking screw
- ▶ Delivered in individual packages

**5152 101 :**  
Blattform zylindrisch 10 x 75mm

**5152 101 :**  
Cylindrical leaf 10 x 75mm

**5150 1.. :**  
Blattform konisch 13 x 100mm

**5150 1.. :**  
Conical leaf 13 x 100mm

! Andere Satzzusammenstellungen, Zollsätze sowie Sätze aus rostfreiem Stahl auf Anfrage.

! Other set compositions, inch sets and stainless steel sets on request.

Blätter Leaves	mm	mm	kg	Nº
6	0,10 – 0,40	0,10 / 0,15 / 0,20 / 0,25 / 0,30 / 0,40	0,02	5152 101
8	0,03 – 0,10	0,03 / 0,04 – 0,10	0,03	5150 101
8	0,05 – 0,50	0,05 / 0,10 / 0,15 / 0,20 / 0,25 / 0,30 / 0,40 / 0,50	0,03	5150 102
10	0,03 – 0,50	0,03 / 0,04 / 0,05 / 0,10 / 0,15 / 0,20 / 0,25 / 0,30 / 0,40 / 0,50	0,06	5150 103
10	0,10 – 1,00	0,10 / 0,20 – 1,00	0,06	5150 104
13	0,05 – 1,00	0,05 / 0,10 / 0,15 / 0,20 / 0,25 / 0,30 / 0,40 – 1,00	0,05	5150 105
18	0,05 – 1,00	0,05 / 0,06 – 0,10 / 0,15 – 0,35 / 0,40 / 0,50 – 1,00	0,07	5150 108
19	0,03 – 1,00	0,03 / 0,04 – 0,10 / 0,15 / 0,20 / 0,25 / 0,30 / 0,40 – 1,00	0,08	5150 109
20	0,05 – 1,00	0,05 / 0,10 – 1,00	0,08	5150 110
20	0,10 – 2,00	0,10 / 0,20 – 2,00	0,2	5150 111



No. 5150 105



No. 5150 110

## Fühlerlehrensätze

## Thickness/Feeler gauge sets, brass



- ▶ Messingblättchen antimagnetisch
- ▶ mit Nennmaß beschriftet
- ▶ Blattform konisch 13x100mm
- ▶ Bügel mit Feststellschraube
- ▶ Lieferung einzeln verpackt

- ▶ Anti-magnetic brass leaves
- ▶ Nominal size marked
- ▶ Conical leaf 13 x 100mm
- ▶ Frame with locking screw
- ▶ Delivered in individual packages

Blätter Leaves	mm	mm	kg	Nº
8	0,05 – 0,50	0,05 / 0,10 / 0,15 / 0,20 / 0,25 / 0,30 / 0,40 / 0,50	0,04	5150 502
13	0,05 – 1,00	0,05 / 0,10 / 0,15 / 0,20 / 0,25 / 0,30 / 0,40 – 1,00	0,07	5150 503
20	0,05 – 1,00	0,05 / 0,10 – 1,00	0,11	5150 504



No. 5150 503

## Fühlerlehrensätze im Ring

## Thickness/Feeler gauge sets, on rings



- ▶ Stahlblättchen federhart
- ▶ mit Nennmaß beschriftet
- ▶ Blattform zylindrisch 13mm
- ▶ Lieferung einzeln verpackt

- ▶ Spring steel leaves
- ▶ Nominal size marked
- ▶ Cylindrical leaf 13mm
- ▶ Delivered in individual packages

! Andere Längen sowie einzelne Fühlerlehrenblätter mit oder ohne Plastikgriff auf Anfrage.

! Other lengths and individual leaves with or without plastic handle on request

Blätter Leaves	mm	mm	mm	kg	Nº
13	0,05 – 1,00	0,05 / 0,10 / 0,15 / 0,20 / 0,25 / 0,30 / 0,40 – 1,00	150	0,08	5151 201
			200	0,12	5151 202
			300	0,15	5151 203
			500	0,31	5151 205
20	0,05 – 1,00	0,05 / 0,10 – 1,00	150	0,17	5151 301
			200	0,22	5151 302
			300	0,44	5151 303
			500	0,55	5151 305
20	0,10 – 2,00	0,10 / 0,20 – 2,00	150	0,4	5151 401
			200	0,52	5151 402
			300	0,78	5151 403
			500	1,3	5151 405



No. 5151 203

## Fühlerlehrenband in Dosen

## Thickness / feeler gauge strips in boxes



- ▶ Bandstahl federhart
- ▶ ab 0,04mm mit Nennmaß markiert
- ▶ Länge 5000mm, Breite 13mm
- ▶ Lieferung in Kunststoffdose

- ▶ Spring steel
- ▶ Nominal size marked from 0.04mm
- ▶ Length 5000mm, width 13mm
- ▶ Delivered in plastic box

! andere Stärken sowie rostfreier Stahl auf Anfrage.

! Other thicknesses and stainless steel version on request.

mm	± μ	kg	Nº	mm	± μ	kg	Nº
0,005	1,5	0,03	5156 100	0,30	7	0,18	5156 116
0,01	1,5	0,04	5156 101	0,35	7	0,21	5156 117
0,02	1,5	0,04	5156 102	0,40	9	0,26	5156 118
0,03	3	0,04	5156 103	0,45	9	0,28	5156 119
0,04	3	0,05	5156 104	0,50	9	0,34	5156 120
0,05	3	0,05	5156 105	0,55	9	0,36	5156 121
0,06	3	0,05	5156 106	0,60	11	0,39	5156 122
0,07	4	0,06	5156 107	0,65	11	0,42	5156 123
0,08	4	0,06	5156 108	0,70	12	0,43	5156 124
0,09	4	0,07	5156 109	0,75	12	0,44	5156 125
0,10	4	0,08	5156 110	0,80	13	0,45	5156 126
0,12	4	0,09	5156 111	0,85	13	0,48	5156 127
0,15	5	0,1	5156 112	0,90	14	0,52	5156 128
0,18	5	0,11	5156 113	0,95	14	0,53	5156 129
0,20	6	0,13	5156 114	1,00	16	0,54	5156 130
0,25	6	0,15	5156 115	Halter für Fühlerlehrenband Gauge strip holder		0,02	5157 101



No. 5156 114



No. 5156 126



No. 5157 101

## Fühlerlehrenband mit Wandhalter

## Thickness / feeler gauge strips with wall holder



- ▶ Bandstahl federhart
- ▶ ab 0,04mm mit Nennmaß markiert
- ▶ Länge 5000mm, Breite 13mm
- ▶ Lieferung einzeln verpackt

- ▶ Spring steel
- ▶ Nominal size marked from 0.04mm
- ▶ Length 5000mm, width 13mm
- ▶ Delivered in individual packages

### Inhalt:

- ▶ 15 Stück Fühlerlehrenbänder in Dosen Nr. 5156 1..
- ▶ 1 Stück Halter für Fühlerlehrenband Nr. 5157 101
- ▶ 1 Stück Wandhalter

### Contents:

- ▶ 15 piece feeler gauge strips in boxes No. 5156 1..
- ▶ 1 piece gauge strip holder No. 5157 101
- ▶ 1 piece wall holder



No. 5157 201

Stück Pieces	mm	mm	kg	Nº
15	0,01 – 0,10 0,12 – 0,18 0,20 / 0,25	0,01 0,03 -	2,5	5157 201
15	0,30 – 1,00	0,05	3,2	5157 202



15 Stück Dosen im Set  
15 pieces boxes in set

## Unterlagsfolien Präzisions-Lehrenband

## Shim stock Precision gauge strips



- ▶ Einstellen, Ausrichten und Justieren von Vorrichtungen, Maschinen etc.
- ▶ Länge 2500mm, Breite 150mm
- ▶ Lieferung in Kunststoffbox, stapelbar

- ▶ Setting up, alignment and adjustment of devices, machines, etc.
- ▶ Length 2500mm, width 150mm
- ▶ Delivered in stackable plastic box

**5158 5.. :**  
Spezialstahl, kaltgewalzt

**5158 5.. :**  
Special steel, cold-rolled

**5159 5.. :**  
rostfreier Stahl

**5159 5.. :**  
Stainless steel

**5160 5.. :**  
Messing, antimagnetisch

**5160 5.. :**  
Brass, anti-magnetic

**!** Andere Bandbreite oder Stärke auf Anfrage.

**!** Other strip widths or thicknesses on request.

mm	kg	± μ	Nº	± μ	Nº	± μ	Nº
0,025	0,2	5	5158 501	2	5159 501	2	5160 501
0,05	0,28	5	5158 502	3	5159 502	3	5160 502
0,075	0,36	5	5158 503	5	5159 503	5	5160 503
0,1	0,45	5	5158 504	5	5159 504	5	5160 504
0,15	0,59	10	5158 505	5	5159 505	5	5160 505
0,2	0,78	10	5158 506	7	5159 506	7	5160 506
0,25	0,93	10	5158 507	7	5159 507	7	5160 507
0,3	1,24	15	5158 508	7	5159 508	7	5160 508
0,4	1,58	15	5158 509	10	5159 509	10	5160 509
0,5	1,91	15	5158 510	10	5159 510	10	5160 510



Sonderbandbreiten auf Anfrage.  
Special strip widths on request.



## Gewindeschablonen

## Screw pitch gauges



- ▶ Außen- und Innenmessung
- ▶ Stahlblättchen
- ▶ mit Steigung beschriftet
- ▶ Bügel mit Feststellschraube
- ▶ Lieferung einzeln verpackt

- ▶ External and internal measuring
- ▶ Steel leaves
- ▶ Pitch marked
- ▶ Frame with locking screw
- ▶ Delivered in individual packages

**!** Andere Ausführungen auf Anfrage.

**!** Other versions on request.



Blätter Leaves	mm	Gewinde Thread	kg	Nº
24	0,25 – 6,0	60° metrisch ISO 60° Metric ISO	0,04	5169 101
20	0,4 – 7,0	60° metrisch S.I. 60° Metric S.I.	0,03	5169 102
20	4 – 30	55° Whitworth 55° Whitworth	0,03	5169 104
28	4 – 62	55° Whitworth 55° Whitworth	0,05	5169 105
6	8 – 28	55° Whitworth Rohr DIN 259 55° Whitworth pipe DIN 259	0,02	5169 106
48	4 – 62 / 0,4 – 7,0	55° Whitworth / 60° metrisch S.I. 55° Whitworth / 60° Metric S.I.	0,08	5169 107
52	4 – 62 / 0,25 – 6,0	55° Whitworth / 60° metrisch ISO 55° Whitworth / 60° Metric ISO	0,08	5169 108
58	4 – 62 / 0,25 – 6 / 8 – 28	55° Whitworth / 60° metrisch ISO / 55° Whitworth Rohr DIN 259 55° Whitworth / 60° metric ISO / 55° Whitworth pipe DIN 259	0,09	5169 109
22	4 – 64	60° UNC Gewinde 60° UNC thread	0,03	5169 110
16	12 – 80	60° UNF Gewinde 60° UNF thread	0,02	5169 111
14	10 – 40	60° US-Gewinde 60° US thread	0,02	5169 112
30	4 – 42	60° US-Gewinde 60° US thread	0,04	5169 113

**Profillehren**

**Contour gauges**



► zum Abnehmen und Übertragen aller Formen

► For reproduction and transfer of all shapes

**5170 1.. :**  
Federharte Stifte  $\varnothing$  0,08mm

**5170 1.. :**  
Spring tempered pins  $\varnothing$  0.08mm

**5171 1.. :**  
Kunststoffnadeln  $\varnothing$  1,5mm

**5171 1.. :**  
Plastic pins  $\varnothing$  1.5mm

$\frac{L}{mm}$ mm	$\frac{B}{mm}$ mm	$\frac{M}{kg}$ kg	Nº
150 x 40	154 x 85	0,2	5170 101
300 x 60	350 x 150	1,0	5170 102
250 x 50	320 x 105	0,54	5171 101

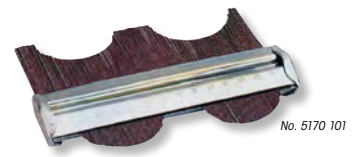

**Fasenmessgerät**

**Chamfer gauge**



- Werkstoffnorm
- rostfreier Stahl
- Ableseteile mattverchromt
- Schiene auswechselbar 30°, 45°, 60°
- Lieferung im Etui

- Works standard
- Stainless steel
- Satin chrome reading parts
- Interchangeable rule 30°, 45°, 60°
- Delivered in a case

$\frac{L}{mm}$ mm	$\frac{R}{mm}$ mm	$\frac{M}{kg}$ kg	Nº
0 – 10mm	0,1mm	0,2	5162 201

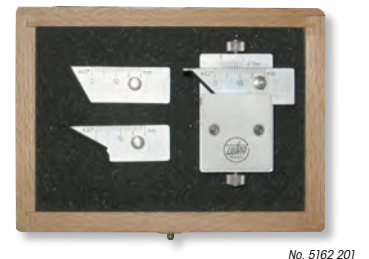

**Radiusmessgerät**

**Radius gauge**



- Werkstoffnorm
- rostfreier Stahl
- Ableseteile mattverchromt
- Lieferung im Etui

- Works standard
- Stainless steel
- Satin chrome reading parts
- Delivered in a case

$\frac{L}{mm}$ mm	$\frac{R}{mm}$ mm	$\frac{M}{kg}$ kg	Nº
0 – 10mm	0,1mm	0,2	5162 301



**Radiuslehren, einzeln**

**Radius gauges, singles**



- Werkstoffnorm
- Spezialstahl feingeschliffen, ungehärtet
- mit einem Innen und Außenradius

- Works standard
- Special steel finely ground, not hardened
- with one inside and outside radius

**5165 1.. :**  
Radiuslehren R 0,5 – 100mm auf Anfrage

**5165 1.. :**  
Radius gauges R 0.5 – 100mm on request



## Radienschablonen

## Radius gauges



TOP

- ▶ Stahlblättchen
- ▶ mit Nennmaß markiert
- ▶ Bügel mit Feststelmutter
- ▶ Lieferung einzeln verpackt

- ▶ Steel leaves
- ▶ Nominal size marked
- ▶ Frame with locking screw
- ▶ Delivered in individual packages

5161 1.. :

Normalstahl

5161 1.. :

Normal steel

5161 2.. :

rostfreier Stahl

5161 2.. :

Stainless steel



No. 5161 102

Blätter Leaves	mm	Radius / Radius mm	kg	Nº	Nº
17	1,0 – 7,0	1,00 / 1,25 / 1,50 / 1,75 / 2,00 / 2,25 2,50 / 2,75 / 3,00 / 3,50 / 4,00 / 4,50 5,00 / 5,50 / 6,00 / 6,50 / 7,00	0,09	5161 101	5161 201
16	7,5 – 15,0	7,50 / 8,00 / 8,50 / 9,00 / 9,50 / 10,0 10,5 / 11,0 / 11,5 / 12,0 / 12,5 / 13,0 13,5 / 14,0 / 14,5 / 15,0	0,12	5161 102	5161 202
15	15,5 – 25,0	15,5 / 16,0 / 16,5 / 17,0 / 17,5 / 18,0 18,5 / 19,0 / 19,5 / 20,0 / 21,0 / 22,0 23,0 / 24,0 / 25,0	0,12	5161 103	5161 203

## Winkellehre

## Angle gauges



- ▶ Stahlblättchen
- ▶ mit Nennmaß markiert
- ▶ Bügel mit Feststelmutter
- ▶ Lieferung einzeln verpackt

- ▶ Steel leaves
- ▶ Nominal size marked
- ▶ Frame with locking screw
- ▶ Delivered in individual packages

Blätter Leaves	mm	°	kg	Nº
20	1 – 45°	1°, 2°, 3°, 4°, 5°, 6°, 7°, 8°, 9°, 10°, 12°, 14°, 16°, 18°, 20°, 25°, 30°, 35°, 40°, 45°	0,10	5162 101

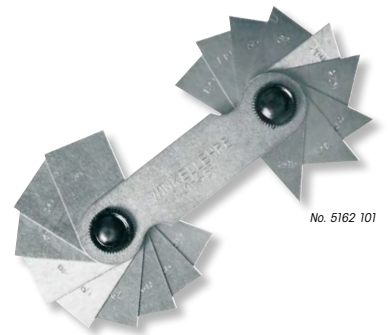

No. 5162 101

## Düsenlehre

## Jet gauges



- ▶ Stahlstifte in Kunststoffassung
- ▶ mit Nennmaß markiert
- ▶ Bügel mit Feststelmutter
- ▶ Lieferung einzeln verpackt

- ▶ Steel pins in plastic holder
- ▶ Nominal size marked
- ▶ Frame with locking screw
- ▶ Delivered in individual packages

Stifte Pins	Ø mm	kg	Nº
20	0,45 – 1,5	0,07	5163 301
16	1,50 – 3,0	0,09	5163 302



No. 5163 301

## Düsenlehre Präzisionsausführung

## Jet gauges, precision model



- ▶ runde Nadel gehärtet
- ▶ Ablesung 0,01mm am Nonius
- ▶ Kegel 1 : 10
- ▶ Gehäuse und Schutzkappe vernickelt
- ▶ Lieferung einzeln verpackt

- ▶ Round hardened pin
- ▶ Reading 0.01mm on vernier
- ▶ Taper 1 : 10
- ▶ Nickel-plated housing and protective cap
- ▶ Delivered in individual packages

Ø mm	<math>\alpha</math> mm	kg	Nº
0 – 3	0,01	0,03	5165 301
0 – 5	0,01	0,07	5165 302



No. 5165 301



## Messkeile

## Taper slot gauges



- ▶ Teilung 0,1mm
- ▶ mit Griff
- ▶ Lieferung einzeln verpackt

- ▶ Graduation 0.1mm
- ▶ with handle
- ▶ Delivered in individual packages

mm	< mm	kg	Nº
Spezialstahl mattverchromt / Satin chrome special steel			
0,5 – 7	0,1	0,04	5166 301
0,5 – 11	0,1	0,06	5166 302
2 – 7	0,1	0,04	5166 303
7 – 15	0,1	0,06	5166 304
Kunststoff / Plastic			
0,5 – 11	0,1	0,04	5166 502

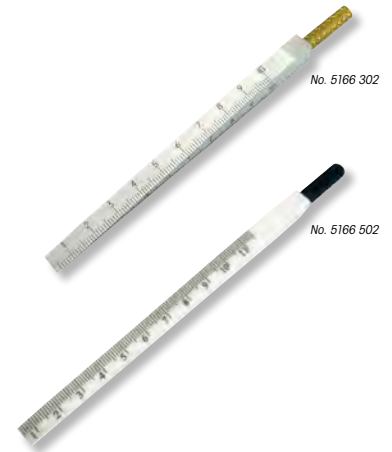

## Lochlehren Millimeterlehren

## Drill and steel wire gauges



- ▶ Spezialstahl nitriert
- ▶ mit Durchmessern markiert
- ▶ Lieferung einzeln verpackt

- ▶ Nitrided special steel
- ▶ Diameters marked
- ▶ Delivered in individual packages

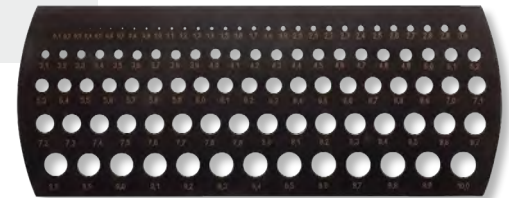

! Andere Ausführungen auf Anfrage.

! Other versions on request.

Ø mm	mm	Bohrungen / Stück Hole / Pieces	kg	Nº
0,1 – 10	0,10	100	0,19	5167 101

No. 5167 101

## Bohrungslehren

## Taper bore gauges



- ▶ Spezialstahl
- ▶ Ablesung 0,1mm
- ▶ Lieferung einzeln verpackt

- ▶ Special steel
- ▶ Reading 0.1mm
- ▶ Delivered in individual packages

**5168 2.. :**  
runde Ausführung, gehärtet

**5168 2.. :**  
Hardened round type

**5168 3.. :**  
flache Ausführung

**5168 3.. :**  
Flat type

! Andere Größen auf Anfrage.

! Other sizes on request.

mm	kg	Nº	mm	kg	Nº
1 – 6	0,03	5168 201	1 – 15	0,02	5168 301
4 – 15	0,2	5168 202	15 – 30	0,06	5168 302
15 – 30	0,9	5168 203	30 – 45	0,12	5168 303
30 – 45	1,8	5168 204			
45 – 60	2,1	5168 205			
60 – 75	2,4	5168 206			
75 – 90	3,1	5168 207			
90 – 105	4,5	5168 208			
105 – 120	6,0	5168 209			



## Digital-Schnellmessgeräte für Spalt- und Versatzmessung

## Digital caliper, step gauge for flush and gap measurement



★ NEW

- ▶ Werksnorm
- ▶ Wiederholgenauigkeit 0,01mm
- ▶ Lieferung im Etui

### Funktionen:

- ▶ Ein/Aus
- ▶ Auto-On bei Bewegung
- ▶ mm/inch Umschaltung
- ▶ 0-Punkt an jeder Position

- ▶ Works standard
- ▶ Repeatability 0.01mm
- ▶ Delivered in a case

### Functions:

- ▶ On/Off
- ▶ Auto-On by sliding
- ▶ mm/inch commutation
- ▶ Zero setting at any position



No. 4000 102

4000 1.. :

ohne Datenausgang

4000 1.. :

with data output

4000 2.. :

mit Datenausgang

4000 2.. :

without data output

Spaltmessung / Gap measurement mm	Versatzmessung / Flush measurement mm	mm/inch	kg	Nº	Nº
1 – 24	- 6 – 24	0,01/ .0005	0,2	4000 101	4000 201
Kurze Bauform (40mm kürzer) / Short construction dimensions (40mm shorter)					
1 – 10	- 5 – 5	0,01/ .0005	0,18	4000 102	4000 202
Datenkabel USB (2m) / Data cable USB (2m)				1850 216	



Messflächen für Spaltmessung  
Measuring faces for gap measurement

## Digital-Schnellmessgeräte für Versatzmessung

## Digital caliper, step gauge for flush measurements



★ NEW

- ▶ Werksnorm
- ▶ Wiederholgenauigkeit 0,01mm
- ▶ mit Messbasis für Messung auf geraden oder gekrümmten Oberflächen
- ▶ Kunststoffmessspitzen verhindern Beschädigungen am Werkstück
- ▶ Lieferung im Etui

### Funktionen:

- ▶ Ein/Aus
- ▶ Auto-On bei Bewegung
- ▶ mm/inch Umschaltung
- ▶ 0-Punkt an jeder Position

- ▶ Works standard
- ▶ Repeatability 0.01mm
- ▶ Base designs allow measurements on both flat and curved surfaces
- ▶ Plastic contact points won't scratch or mark delicate surfaces
- ▶ Delivered in a case

### Functions:

- ▶ On/Off
- ▶ Auto-On by sliding
- ▶ mm/inch commutation
- ▶ Zero setting at any position



No. 4002 101

4002 101 :

ohne Datenausgang

4002 101 :

with data output

4002 201 :

mit Datenausgang

4002 201 :

without data output

mm	mm/inch	kg	Nº	Nº
- 6 – 13	0,01/ .0005	0,2	4002 101	4002 201
Datenkabel USB (2m) / Data cable USB (2m)				1850 216



**Bohrungslehren Satz**

**Hole gauge sets**



**Gehärtet  
Hardened**

- ▶ Messflächen gehärtet
- ▶ Griffe gerändelt
- ▶ auch für Sacklochbohrungen
- ▶ Lieferung in Etui

- ▶ Hardened measuring faces
- ▶ Knurled handle
- ▶ Also for blind bores
- ▶ Delivered in a case

**!** In Bohrung einführen, Messflächen spreizen und klemmen. Lehre aus Bohrung entfernen, Ø mit Messschieber oder Messschraube bestimmen.

**!** Splay and clamp measuring faces to insert bore. Remove gauge from bore; determine Ø with calipers or micrometer.



No. 5024 101

mm / inch	kg	Nº
3,2 – 12,7 / .125 – .500	0,15	5024 101

**Teleskoplehren Satz**

**Telescope gauge sets**



**Gehärtet  
Hardened**

- ▶ Messflächen ballig, gehärtet
- ▶ Griffe gerändelt
- ▶ Lieferung in Etui

- ▶ Hardened spherical measuring faces
- ▶ Knurled handle
- ▶ Delivered in a case

**!** In Bohrung einführen, Messflächen spreizen und klemmen. Lehre aus Bohrung entfernen, Ø mit Messschieber oder Messschraube bestimmen.

**!** Splay and clamp measuring faces to insert in bore. Remove gauge from bore; determine Ø with caliper or micrometer.



No. 5015 101

mm / inch	kg	Nº
8 – 150 / .32 – 6	0,55	5015 101

**Spiralbohrer-Schleiflehren**

**Twist drill grinding gauges**



- ▶ Spezialstahl
- ▶ Lieferung einzeln verpackt

- ▶ Special steel
- ▶ Delivered in individual packages

Typ Type	kg	Nº
Winkel 118° bis Ø 50mm Angle 118° up to Ø 50mm	0,02	5161 301
Winkel 120° / 118° / 90° / 60° / 55° Angle 120° / 118° / 90° / 60° / 55°	0,03	5161 302
Verstellbarer Winkel 30° – 160° bis Ø 60mm Adjustable angle 30° – 160° up to Ø 60mm	0,03	5161 303
Verstellbarer Anschlag, Nonius 1/10mm, Winkel 118° bis Ø 50mm Adjustable stop, vernier 1/10mm, angle 118° up to Ø 50mm	0,03	5161 304



No. 5161 304



No. 5161 301



No. 5161 302



No. 5161 303

1  
2  
3  
4  
5  
6  
7  
8  
9  
10  
11  
12  
13  
14  
15

## Schweißnahtlehre

## Weld seam gauges



- ▶ Spezialstahl
- ▶ fächerartig
- ▶ Lieferung einzeln verpackt

- ▶ Special steel
- ▶ Fan shaped
- ▶ Delivered in individual packages



No. 5176 101

Typ Type	kg	Nº
12 Blatt 3 – 12mm 12 leaf 3 – 12mm	0,08	5176 101

## Schweißnahtlehre

## Weld seam gauges



**ALUMINIUM**

- ▶ Aluminium
- ▶ beidseitig bedruckt
- ▶ Lieferung einzeln verpackt

- ▶ Aluminium
- ▶ Both sides printed
- ▶ Delivered in individual packages

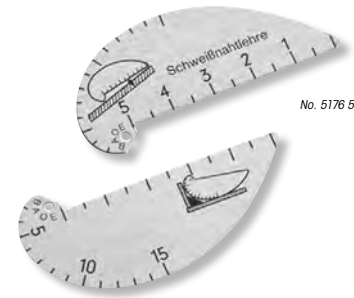

No. 5176 501

Typ Type	kg	Nº
2 – 15mm Ecknähte / 0 – 5mm Flachnähte 2 – 15mm corner seam / 0 – 5mm flat seam	0,01	5176 501

## Schweißnahtlehre

## Weld seam gauges



**Gehärtet  
Hardened**

- ▶ rostfreier Stahl, gehärtet
- ▶ Lieferung einzeln verpackt

- ▶ Hardened stainless steel
- ▶ Delivered in individual packages

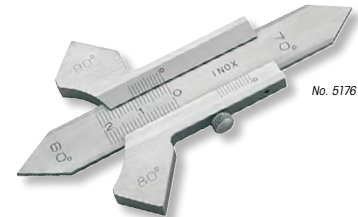

No. 5176 102

**5176 102 :**

Nonius 1/10mm

**5176 102 :**

Vernier 1/10mm

**5176 302 :**

Ablesung 0,01mm digital

**5176 302 :**

Digital reading 0.01mm



No. 5176 302

Typ Type	mm	kg	Nº	Nº
Winkel 60° / 70° / 80° / 90° Angle 60° / 70° / 80° / 90°	0 – 20	0,07	5176 102	5176 302

## Schweißnahtlehre DBP

## Weld seam gauges DBP



- ▶ rostfreier Stahl
- ▶ Direktablesung 0,1mm
- ▶ Vergrößerungsglas
- ▶ Lieferung in Ledertasche

- ▶ Stainless steel
- ▶ Direct reading 0.1mm
- ▶ Magnifying glass
- ▶ Delivered in leather bag

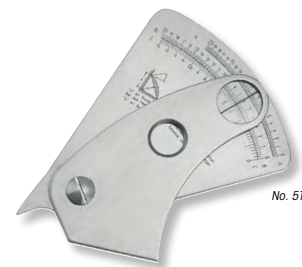

No. 5176 103

Typ Type	kg	Nº
0 – 20mm	0,07	5176 103

**Drehstahllehren**

**Lathe tool gauges**



- Spezialstahl
- Lieferung einzeln verpackt

- Special steel
- Delivered in individual packages

Typ Type	kg	Nº
Hartmetallstähle 55° – 75° Tungsten carbide steels 55° – 75°	0,05	<b>5160 701</b>
Schneldrehstähle 45° – 62° High speed steels 45° – 62°	0,05	<b>5160 702</b>

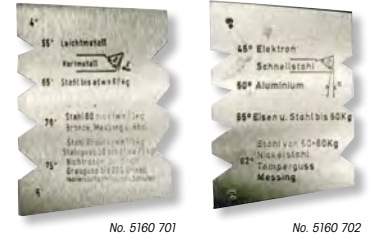

**Gewindestahllehren**

**Screw-cutting gauges**



- Spezialstahl
- Lieferung einzeln verpackt

- Special steel
- Delivered in individual packages

Typ Type	kg	Nº	
Spitz-Gewinde Centre thread	55° Whitworth Gewinde 55° Whitworth thread	0,01	<b>5168 101</b>
Spitz-Gewinde Centre thread	60° metrisches Gewinde 60° Metric thread	0,01	<b>5168 102</b>
Universal Universal	Alle Spitz- und Flachgewinde All V threads and square threads	0,01	<b>5168 103</b>
Trapez Trapezoidal	2 – 12mm DIN 103, Flankenwinkel 30° 2 – 12 mm DIN 103, flank angle 30°	0,01	<b>5168 104</b>
ACME	1 – 10 Gang, Trapez 29° 1-10 pitch, trapezoidal 29°	0,02	<b>5168 105</b>
Kombiniert Combined	Flach-, Trapez-, Spitzgewinde 55° und 60° Square, trapezoidal and V threads 55° and 60°	0,05	<b>5168 106</b>
Universal Universal	metr. amerik. 60° Ww-BSF 55°, 14½° Acme und 47½° BA Metr. American 60° Ww-BSF 55°, 14½° Acme and 47½° BA	0,02	<b>5168 109</b>

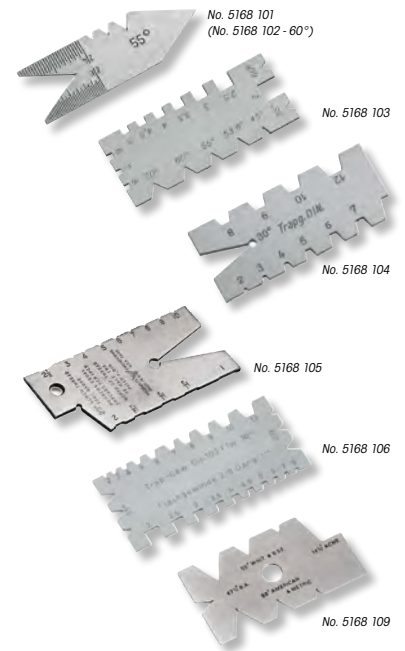

**Dreh- und Gewindestahllehren kombiniert**

**Lathe and screw-cutting gauges combined**



- Spezialstahl
- Lieferung einzeln verpackt

- Special steel
- Delivered in individual packages

**5168 107 :** ohne Anschläge **5168 107 :** Without stop

**5168 108 :** mit Freiwinkelanschlag 0 – 30° **5168 108 :** With clearance angle stop 0 – 30°

Typ Type	kg	Nº	Nº
Winkel 40° – 80°; Trapez-, Spitzgewinde 55° und 60° Angle 40° – 80°; trapezoidal and V threads 55° and 60°	0,05	<b>5168 107</b>	<b>5168 108</b>



## Knopfmaße Kleinmessschieber

## Pocket slip calipers (Button gauges)



- ▶ Hartmessing
- ▶ Lieferung einzeln verpackt

- ▶ Hard brass
- ▶ Delivered in individual packages

**5069 103 / 106 :**  
Standard

**5069 103 / 106 :**  
Standard

**5069 109 / 112 :**  
Lochmaßansatz 5mm

**5069 109 / 112 :**  
Nib for inside measurement 5mm

! Andere Modelle auf Anfrage.

! Other versions on request.

mm / inch	mm	mm / inch	kg	Nº	Nº
100 / 4	20	1/1 - 1/16	0,04	<b>5069 103</b>	<b>5069 109</b>
100 / 4	20	1/10 - 1/16	0,04	<b>5069 106</b>	<b>5069 112</b>

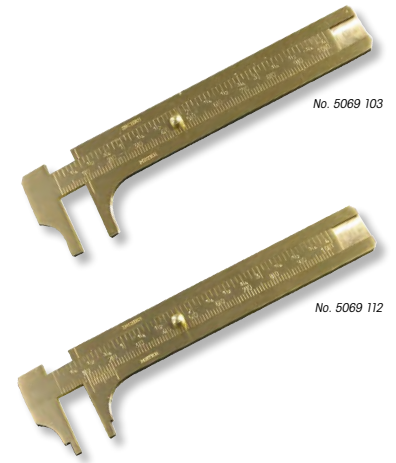

## Reifenprofilmaße Tiefenmaße

## Tyre tread depth gauges



- ▶ Hartmessing
- ▶ Lieferung einzeln verpackt

- ▶ Hard brass
- ▶ Delivered in individual packages

! Rostfreie Ausführung auf Anfrage.

! Stainless steel version on request.

mm	mm	mm	kg	Nº
30	20	1/10	0,03	<b>5174 101</b>
50	50	1/10	0,04	<b>5174 102</b>
50	25	1/10	0,04	<b>5174 103</b>



## Federlehren Zehntelmaße

## Spring gauges Thickness calipers



- ▶ Messingskala
- ▶ Lieferung einzeln verpackt

- ▶ Brass scale
- ▶ Delivered in individual packages

mm	mm	mm	kg	Nº
10	80	1/10	0,04	<b>5172 101</b>
15	125	1/10	0,07	<b>5172 102</b>
20	150	1/10	0,11	<b>5172 103</b>



## Sonderskalen und Nonien

## Special scales and verniers



Wir liefern jede Art von Sonderskalen und Zifferblätter mit hochgenauer Laserteilung, aus Stahl, rostfreiem Stahl, Messing, Aluminium etc. Zur Angebotserstellung bitten wir um Ihre Anfrage mit Zeichnungsunterlagen.

We supply all types of special scales and dials with highly accurate laser scale, made of steel, stainless steel, brass, aluminium, etc. For the preparation of a quotation, we request you to send us your drawings.



# 10

**Winkel**  
Squares

**Winkelmesser**  
Bevel protractors

**Gradmesser**  
Protractors

**Richtwaagen**  
Engineer's levels

**Wasserwaagen**  
Spirit levels



★ **NEW**



### Winkel nach DIN 875

Diese Norm gilt für Flachwinkel (Form A), Anschlagwinkel (Form B) und Haarwinkel (Form C) aus Stahl mit einem Winkel von 90° und einer Schenkellänge bis 1500mm.

#### Winkeltoleranzen

Die Berechnung erfolgt nach den in der Tabelle angegebenen Formeln (die Toleranzen sind gerundet). Für die Parallelität der Messflächen zueinander gelten die gleichen Werte.

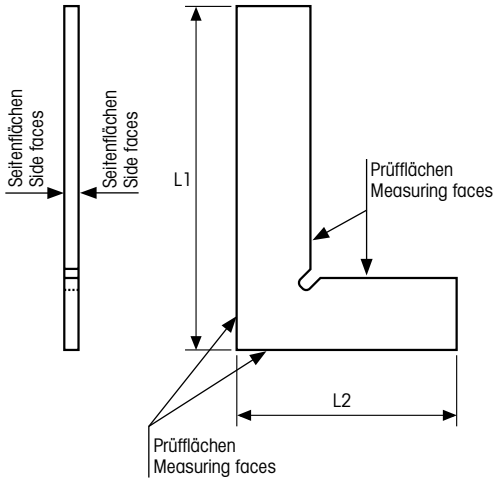

### Squares according to DIN 875

This standard is valid for flat squares (design A), back squares (design B) and bevel edge squares (design C), of steel with a 90° angle and a leg length up to 1500 mm.

#### Angle tolerances

The calculation is done according to the formulas given in the table; the tolerances are rounded off. Equal values are applicable for the parallelism of the measuring surfaces to one another.

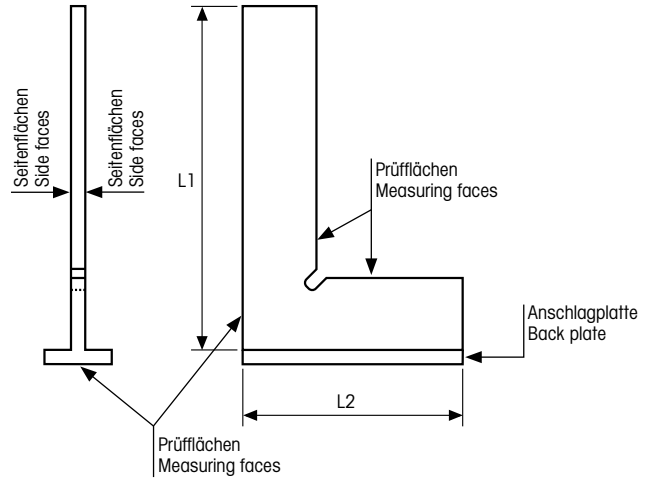

L = Schenkellänge L1 oder L2

Länge / Length L = mm	00 (2 + L/100)μ	0 (5 + L/50)μ	1 (10 + L/20)μ	2 (20 + L/10)μ
50	3	-	-	-
75	3	7	14	28
100	3	7	15	30
150	4	8	18	35
200	4	9	20	40
250	5	10	23	45
300	5	11	25	50
400	-	13	30	60
500	-	15	35	70
600	-	17	40	80
750	-	20	43	85
1000	-	25	60	120
1500	-	35	85	170

L = Leg lengths L1 or L2

#### Ebenheitstoleranzen

Die Ebenheit der Prüfflächen bzw. Geradheit der Haarmesskanten wird mit folgenden Formeln errechnet:

L = Schenkellänge L1 oder L2

00	Formel
00	(2 + L/250)μ
0	(2 + L/100)μ
1	(4 + L/50)μ
2	(8 + L/25)μ

#### Flatness tolerances

The flatness of the test surfaces and/or straightness of the bevelled edge are calculated using the following formulas:

L = Leg lengths L1 or L2

00	Formula
00	(2 + L/250)μ
0	(2 + L/100)μ
1	(4 + L/50)μ
2	(8 + L/25)μ

#### Kalibrierung:

Für alle Winkel können Werkskalibrierscheine erstellt werden. Bitte beachten Sie hierzu unsere Nettopreisliste für die Erstellung von Prüfberichten.

Weitere Informationen erhalten Sie unter:  
[www.ultra-germany.com](http://www.ultra-germany.com) > Produkte > Service > Prüfmittelüberwachung

#### Calibration:

Works calibration certificates are issued for all squares. Please check our net price list for the issue of inspection reports.

More information can be had at:  
[www.ultra-germany.com](http://www.ultra-germany.com) > Products > Service > Calibration



**Messwinkelsatz**

**Measuring square sets**



- ▶ DIN 875
- ▶ Spezialstahl gehärtet
- ▶ Lieferung im Holzetui

- ▶ DIN 875
- ▶ Special steel hardened
- ▶ Delivered in a wooden case

**Inhalt:**

- ▶ Haarwinkel 25 x 20mm
- ▶ Haarwinkel 40 x 28mm
- ▶ Haarwinkel 75 x 50mm
- ▶ Haarlineal 100mm
- ▶ Anreißspitze 60mm

**Contents:**

- ▶ Die maker's square 25 x 20mm
- ▶ Die maker's square 40 x 28mm
- ▶ Bevel edge square 75 x 50mm
- ▶ Knife straightedge 100mm
- ▶ Scriber 60mm



No. 1952 101

Stück Pieces	kg	Nº
5	0,25	1952 101

**Schnittmacherwinkel gehärtet**

**Die maker's squares, hardened**



- ▶ DIN 875
- ▶ rostfreier Stahl, gehärtet
- ▶ Haarmesskante innen 90°
- ▶ Lieferung einzeln verpackt

- ▶ DIN 875
- ▶ Hardened stainless steel
- ▶ Inside bevel edge 90°
- ▶ Delivered in individual packages



No. 1959 101

L mm	kg	Nº
25 x 20	0,005	1959 101
40 x 28	0,005	1959 102

**Schnittmacherwinkel-Satz gehärtet**

**Die maker's square sets, hardened**

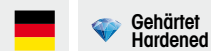

- ▶ DIN 875
- ▶ Spezialstahl gehärtet
- ▶ Haarmesskante innen
- ▶ Lieferung im Holzetui

- ▶ DIN 875
- ▶ Hardened special steel
- ▶ Inside bevel edge
- ▶ Delivered in a wooden case

**Inhalt :**

- ▶ Haarwinkel 89° 30'
- ▶ Haarwinkel 90° 30'

**Contents:**

- ▶ Bevel edge square 89° 30'
- ▶ Bevel edge square 90° 30'

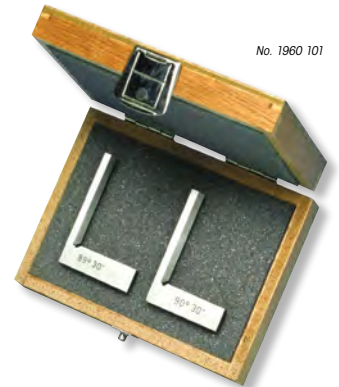

No. 1960 101

L mm	kg	Nº
40 x 28	0,05	1960 101

**Haarwinkel verstellbar**

**Bevel edge squares, adjustable**



- ▶ Werksnorm
- ▶ Spezialstahl, gehärtet
- ▶ Lineal mit Spitze 45°, verschiebbar
- ▶ 2 Haarmesskanten
- ▶ Lieferung in Etui

- ▶ Works standard
- ▶ Hardened special steel
- ▶ Movable straightedge with 45° bevel
- ▶ 2 bevel edges
- ▶ Delivered in a case



No. 1953 201

L mm	kg	Nº
40 x 60	0,1	1953 201

## Haarwinkel verstellbar mit Feinverstellung

## Bevel edge squares, adjustable with fine adjustment



**Gehärtet**  
**Hardened**

- ▶ Werksnorm
- ▶ Spezialstahl, gehärtet
- ▶ Verstellbereich  $\pm 5^\circ$
- ▶ Lineale verschiebbar
- ▶ 2 Haarmesskanten
- ▶ Lieferung in Etui

- ▶ Works standard
- ▶ Hardened special steel
- ▶ Adjustable range  $\pm 5^\circ$
- ▶ Movable straightedges
- ▶ 2 bevel edges
- ▶ Delivered in a case

**1956 101 :**  
Lineal mit Spitze  $45^\circ$

**1956 101 :**  
Straightedge with  $45^\circ$  bevel

**1957 101 :**  
Lineal mit Spitze abgesetzt  $\varnothing 2,5\text{mm}$

**1957 101 :**  
Straightedge with reduced bevel  $\varnothing 2.5\text{mm}$

L mm	kg	Nº
60 x 100	0,25	<b>1956 101</b>
60 x 100	0,25	<b>1957 101</b>



No. 1957 101

No. 1956 101

## Haarwinkel gehärtet

## Bevel edge squares, hardened



**TOP**

**Gehärtet**  
**Hardened**

- ▶ DIN 875 / 00
- ▶ 2 Haarmesskanten
- ▶ Lieferung einzeln verpackt

- ▶ DIN 875 / 00
- ▶ 2 bevel edges
- ▶ Delivered in individual packages

**1961 1.. :**  
Normalstahl gehärtet

**1961 1.. :**  
Hardened normal steel

**1966 1.. :**  
rostfreier Stahl gehärtet

**1966 1.. :**  
Hardened stainless steel

**1971 1.. :**  
Holzetui

**1971 1.. :**  
Wooden box

L mm	kg	Nº	Nº	Nº
50 x 40	0,04	<b>1961 101</b>	<b>1966 101</b>	<b>1971 101</b>
75 x 50	0,05	<b>1961 102</b>	<b>1966 102</b>	<b>1971 102</b>
100 x 70	0,1	<b>1961 103</b>	<b>1966 103</b>	<b>1971 103</b>
150 x 100	0,26	<b>1961 104</b>	<b>1966 104</b>	<b>1971 104</b>
200 x 130	0,43	<b>1961 105</b>	<b>1966 105</b>	<b>1971 105</b>
300 x 200	0,95	<b>1961 106</b>	<b>1966 106</b>	<b>1971 107</b>



No. 1966 103

## Haarwinkel gehärtet mit starkem und schwachem Schenkel

## Bevel edge squares, hardened with heavy base and thin blade



**Gehärtet**  
**Hardened**

- ▶ DIN 875 / 00
- ▶ 2 Haarmesskanten
- ▶ Lieferung einzeln verpackt

- ▶ DIN 875 / 00
- ▶ 2 bevel edges
- ▶ Delivered in individual packages

**1962 1.. :**  
Normalstahl gehärtet

**1962 1.. :**  
Hardened normal steel

**1967 1.. :**  
rostfreier Stahl gehärtet

**1967 1.. :**  
Hardened stainless steel

**1971 1.. / 1971 2.. :**  
Holzetui

**1971 1.. / 1971 2.. :**  
Wooden box



L mm	kg	Nº	Nº	Nº
50 x 40	0,04	<b>1962 101</b>	<b>1967 101</b>	<b>1971 101</b>
75 x 50	0,05	<b>1962 102</b>	<b>1967 102</b>	<b>1971 102</b>
100 x 70	0,12	<b>1962 103</b>	<b>1967 103</b>	<b>1971 103</b>
150 x 100	0,32	<b>1962 104</b>	<b>1967 104</b>	<b>1971 204</b>
200 x 130	0,65	<b>1962 105</b>	<b>1967 105</b>	<b>1971 205</b>
300 x 200	1,6	<b>1962 106</b>	<b>1967 106</b>	<b>1971 207</b>



No. 1962 103

**Flachwinkel gehärtet**

**Flat squares, hardened**

  **Gehärtet Hardened**

- ▶ DIN 875 / 0
- ▶ Lieferung einzeln verpackt

- ▶ DIN 875 / 0
- ▶ Delivered in individual packages

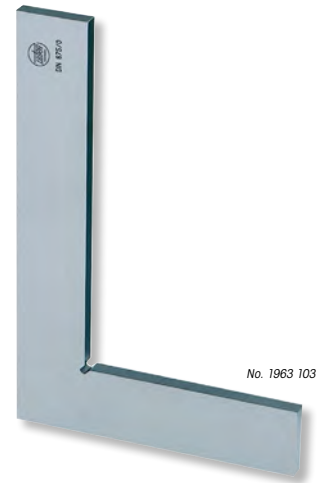

<b>1963 1.. :</b> Normalstahl gehärtet	<b>1963 1.. :</b> Hardened normal steel
<b>1968 1.. :</b> rostfreier Stahl gehärtet	<b>1968 1.. :</b> Hardened stainless steel
<b>1971 1.. :</b> Holzetui	<b>1971 1.. :</b> Wooden box

L mm	kg	Nº	Nº	Nº
50 x 40	0,04	1963 101	1968 101	1971 101
75 x 50	0,05	1963 102	1968 102	1971 102
100 x 70	0,12	1963 103	1968 103	1971 103
150 x 100	0,3	1963 104	1968 104	1971 104
200 x 130	0,6	1963 105	1968 105	1971 105
300 x 200	1,5	1963 106	1968 106	1971 107



**Anschlagwinkel gehärtet**

**Back squares, hardened**

  **Gehärtet Hardened**

- ▶ DIN 875 / 0
- ▶ Lieferung einzeln verpackt

- ▶ DIN 875 / 0
- ▶ Delivered in individual packages

<b>1964 1.. :</b> Normalstahl gehärtet	<b>1964 1.. :</b> Hardened normal steel
<b>1969 1.. :</b> rostfreier Stahl gehärtet	<b>1969 1.. :</b> Hardened stainless steel
<b>1971 1.. / 1971 2.. :</b> Holzetui	<b>1971 1.. / 1971 2.. :</b> Wooden box

L mm	kg	Nº	Nº	Nº
50 x 40	0,04	1964 101	1969 101	1971 101
75 x 50	0,08	1964 102	1969 102	1971 102
100 x 70	0,2	1964 103	1969 103	1971 103
150 x 100	0,46	1964 104	1969 104	1971 204
200 x 130	0,75	1964 105	1969 105	1971 205
300 x 200	1,68	1964 106	1969 106	1971 207



**Anschlagwinkel gehärtet mit starkem und schwachem Schenkel**

**Try squares, hardened with heavy base and thin blade**

  **Gehärtet Hardened**

- ▶ DIN 875 / 0
- ▶ Lieferung einzeln verpackt

- ▶ DIN 875 / 0
- ▶ Delivered in individual packages

<b>1965 1.. :</b> Normalstahl gehärtet	<b>1965 1.. :</b> Hardened normal steel
<b>1970 1.. :</b> rostfreier Stahl gehärtet	<b>1970 1.. :</b> Hardened stainless steel
<b>1971 1.. / 1971 2.. :</b> Holzetui	<b>1971 1.. / 1971 2.. :</b> Wooden box

L mm	kg	Nº	Nº	Nº
50 x 40	0,04	1965 101	1970 101	1971 101
75 x 50	0,05	1965 102	1970 102	1971 102
100 x 70	0,12	1965 103	1970 103	1971 103
150 x 100	0,32	1965 104	1970 104	1971 204
200 x 130	0,65	1965 105	1970 105	1971 205
300 x 200	1,6	1965 106	1970 106	1971 207



## Flachwinkel

## Flat squares



- ▶ DIN 875
- ▶ Lieferung einzeln verpackt

- ▶ DIN 875
- ▶ Delivered in individual packages

### 1977 1.. :

Güte 0 Normalstahl

### 1977 1.. :

Grade 0 Normal steel

### 1981 1.. :

Güte 0 rostfreier Stahl

### 1981 1.. :

Grade 0 Stainless steel

### 1979 1.. :

Güte 1 Normalstahl

### 1979 1.. :

Grade 1 Normal steel

### 1983 1.. :

Güte 1 rostfreier Stahl

### 1983 1.. :

Grade 1 Stainless steel

### 1971 1.. :

Holzsetui

### 1971 1.. :

Wooden box

L mm	h kg	0 Nº	0 Nº	1 Nº	1 Nº	Nº
75 x 50	0,06	1977 101	1981 101	1979 101	1983 101	1971 102
100 x 70	0,08	1977 102	1981 102	1979 102	1983 102	1971 103
150 x 100	0,25	1977 103	1981 103	1979 103	1983 103	1971 104
200 x 130	0,5	1977 104	1981 104	1979 104	1983 104	1971 105
250 x 165	0,9	1977 105	1981 105	1979 105	1983 105	1971 106
300 x 200	1,1	1977 106	1981 106	1979 106	1983 106	1971 107
400 x 265	1,7	1977 107	1981 107	1979 107	1983 107	1971 108
500 x 330	2,8	1977 108	1981 108	1979 108	1983 108	1971 109
600 x 400	3,3	1977 109	1981 109	1979 109	1983 109	1971 110
750 x 500	6,4	1977 110	1981 110	1979 110	1983 110	1971 111
1000 x 660	13,0	1977 111	1981 111	1979 111	1983 111	1971 112

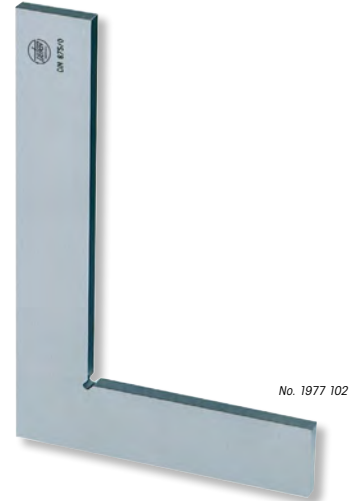

No. 1977 102

## Anschlagwinkel

## Back squares



- ▶ DIN 875
- ▶ Lieferung einzeln verpackt

- ▶ DIN 875
- ▶ Delivered in individual packages

### 1978 1.. :

Güte 0 Normalstahl

### 1978 1.. :

Grade 0 Normal steel

### 1982 1.. :

Güte 0 rostfreier Stahl

### 1982 1.. :

Grade 0 Stainless steel

### 1980 1.. :

Güte 1 Normalstahl

### 1980 1.. :

Grade 1 Normal steel

### 1984 1.. :

Güte 1 rostfreier Stahl

### 1984 1.. :

Grade 1 Stainless steel

### 1971 1.. / 1971 2.. :

Holzsetui

### 1971 1.. / 1971 2.. :

Wooden box

L mm	h kg	0 Nº	0 Nº	1 Nº	1 Nº	Nº
75 x 50	0,1	1978 101	1982 101	1980 101	1984 101	1971 102
100 x 70	0,15	1978 102	1982 102	1980 102	1984 102	1971 103
150 x 100	0,4	1978 103	1982 103	1980 103	1984 103	1971 204
200 x 130	0,7	1978 104	1982 104	1980 104	1984 104	1971 205
250 x 165	1,0	1978 105	1982 105	1980 105	1984 105	1971 206
300 x 200	1,6	1978 106	1982 106	1980 106	1984 106	1971 207
400 x 265	2,7	1978 107	1982 107	1980 107	1984 107	1971 208
500 x 330	4,4	1978 108	1982 108	1980 108	1984 108	1971 209
600 x 400	5,0	1978 109	1982 109	1980 109	1984 109	1971 210
750 x 500	8,9	1978 110	1982 110	1980 110	1984 110	1971 211
1000 x 660	15,8	1978 111	1982 111	1980 111	1984 111	1971 212



No. 1978 102

## Flachwinkel

## Flat squares



- ▶ DIN 875/2
- ▶ Normalstahl
- ▶ Lieferung einzeln verpackt

- ▶ DIN 875 / 2
- ▶ Normal steel
- ▶ Delivered in individual packages

**1985 1.. :**

Flachwinkel

**1985 1.. :**

Flat squares

**1971 1.. :**

Holzetui

**1971 1.. :**

Wooden box

! Winkel aus rostfreiem Stahl auf Anfrage.

! Stainless steel squares on request.

L mm	h kg	Nº	Nº
75 x 50	0,08	1985 101	1971 102
100 x 70	0,1	1985 102	1971 103
150 x 100	0,24	1985 103	1971 104
200 x 130	0,45	1985 104	1971 105
250 x 165	0,55	1985 105	1971 106
300 x 175	0,8	1985 106	1971 107
400 x 200	1,10	1985 107	1971 108

L mm	h kg	Nº	Nº
500 x 250	1,6	1985 108	1971 109
600 x 300	2,0	1985 109	1971 110
750 x 375	3,5	1985 110	1971 111
1000 x 500	6,0	1985 111	1971 112
1500 x 750	10,5	1985 112	1971 113
2000 x 1000	15,0	1985 113	1971 114

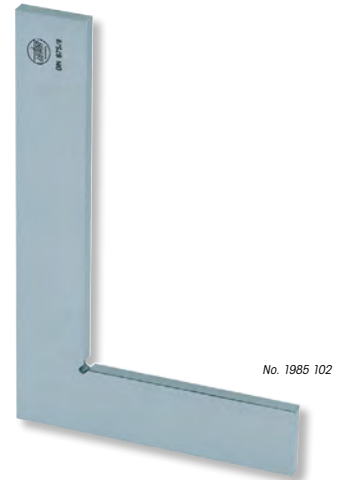

## Anschlagwinkel

## Back squares



- ▶ DIN 875/2
- ▶ Normalstahl
- ▶ Lieferung einzeln verpackt

- ▶ DIN 875 / 2
- ▶ Normal steel
- ▶ Delivered in individual packages

**1987 1.. :**

Anschlagwinkel

**1987 1.. :**

Back squares

**1971 1.. / 1971 2.. :**

Holzetui

**1971 1.. / 1971 2.. :**

Wooden box

! Winkel aus rostfreiem Stahl auf Anfrage.

! Stainless steel squares on request.

L mm	h kg	Nº	Nº
75 x 50	0,1	1987 101	1971 102
100 x 70	0,15	1987 102	1971 103
150 x 100	0,3	1987 103	1971 204
200 x 130	0,65	1987 104	1971 205
250 x 165	0,75	1987 105	1971 206
300 x 175	1,58	1987 106	1971 207
400 x 200	1,88	1987 107	1971 208

L mm	h kg	Nº	Nº
500 x 250	2,3	1987 108	1971 209
600 x 300	2,7	1987 109	1971 210
750 x 375	5,0	1987 110	1971 211
1000 x 500	7,5	1987 111	1971 212
1500 x 750	14,0	1987 112	1971 213
2000 x 1000	21,0	1987 113	1971 214



## Anschlagwinkel mit starkem und schwachem Schenkel

## Try squares with heavy base and thin blade



- ▶ DIN 875/1
- ▶ Normalstahl
- ▶ Lieferung einzeln verpackt

- ▶ DIN 875/1
- ▶ Normal steel
- ▶ Delivered in individual packages

**1989 1.. :**

Anschlagwinkel

**1989 1.. :**

Try squares

**1971 1.. / 1971 2.. :**

Holzetui

**1971 1.. / 1971 2.. :**

Wooden box

L mm	h kg	Nº	Nº
75 x 50	0,06	1989 101	1971 102
100 x 70	0,1	1989 102	1971 103

L mm	h kg	Nº	Nº
150 x 100	0,2	1989 103	1971 204
200 x 130	0,3	1989 104	1971 205



## Spitzwinkel 45° / 60°

## Acute angle squares 45° / 60°



- ▶ Werksnorm
- ▶ Normalstahl
- ▶ Lieferung einzeln verpackt

- ▶ Works standard
- ▶ Normal steel
- ▶ Delivered in individual packages

1991 1.. / 1992 1.. :  
ohne Anschlag

1991 1.. / 1992 1.. :  
Without base

1993 1.. / 1994 1.. :  
mit Anschlag

1993 1.. / 1994 1.. :  
With base

L mm	kg	∠	Nº	Nº
120 x 80	0,2	45°	1991 101	1993 101
150 x 100	0,3	45°	1991 102	1993 102
200 x 130	0,5	45°	1991 103	1993 103

L mm	kg	∠	Nº	Nº
120 x 80	0,2	60°	1992 101	1994 101
150 x 100	0,3	60°	1992 102	1994 102
200 x 130	0,5	60°	1992 103	1994 103

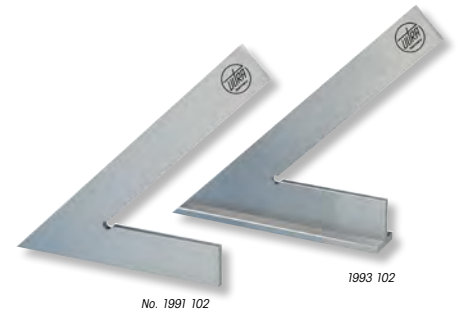

No. 1991 102

1993 102

## Sechskantwinkel 120° Achtkantwinkel 135°

## Hexagon squares 120° Octagon squares 135°



- ▶ Werksnorm
- ▶ Normalstahl
- ▶ Lieferung einzeln verpackt

- ▶ Works standard
- ▶ Normal steel
- ▶ Delivered in individual packages

L mm	kg	∠	Nº	∠	Nº
50 x 50	0,03	120°	1997 101	135°	1998 101
75 x 75	0,08	120°	1997 102	135°	1998 102
100 x 100	0,13	120°	1997 103	135°	1998 103



No. 1997 103

No. 1998 103

## Gehrungswinkel 135°

## Mitre squares 135°



- ▶ Werksnorm
- ▶ Normalstahl
- ▶ mit Anschlag
- ▶ Lieferung einzeln verpackt

- ▶ Works standard
- ▶ Normal steel
- ▶ with base
- ▶ Delivered in individual packages

L mm	kg	∠	Nº
120 x 80	0,2	135°	1998 202
150 x 100	0,3	135°	1998 203
200 x 130	0,5	135°	1998 204



No. 1998 103

## Zentrierwinkel

## Centre squares



- ▶ Werksnorm
- ▶ Normalstahl, mattiert
- ▶ mm Teilung
- ▶ Lieferung einzeln verpackt

- ▶ Works standard
- ▶ Normal steel, satin finish
- ▶ mm graduation
- ▶ Delivered in individual packages

L mm	Wellen / Shaft max. Ø mm	kg	Nº	L mm	Wellen / Shaft max. Ø mm	kg	Nº
100 x 70	90	0,15	1999 101	300 x 180	280	0,76	1999 105
150 x 130	190	0,45	1999 102	400 x 250	380	2,4	1999 106
200 x 150	220	0,58	1999 103	500 x 330	530	3,5	1999 107
250 x 160	230	0,69	1999 104				



No. 1999 102

**Schlosserwinkel**

**Simple squares**



- ▶ Normalstahl verzinkt
- ▶ Lieferung einzeln verpackt

- ▶ Galvanised normal steel
- ▶ Delivered in individual packages

**5188 1.. :**  
Flachwinkel

**5188 1.. :**  
Flat squares

**5188 2.. :**  
Anschlagwinkel

**5188 2.. :**  
Back squares

! Größere Abmessungen auf Anfrage.

! Larger dimensions on request.

L mm	kg	Nº	kg	Nº	L mm	kg	Nº	kg	Nº
100 x 70	0,12	5188 101	0,17	5188 201	400 x 230	0,59	5188 106	0,69	5188 206
150 x 100	0,18	5188 102	0,26	5188 202	500 x 280	0,74	5188 107	0,88	5188 207
200 x 130	0,24	5188 103	0,35	5188 203	600 x 330	1,06	5188 108	1,4	5188 208
250 x 160	0,38	5188 104	0,48	5188 204	750 x 375	1,29	5188 109	1,68	5188 209
300 x 180	0,45	5188 105	0,56	5188 205	1000 x 500	1,74	5188 110	2,25	5188 210

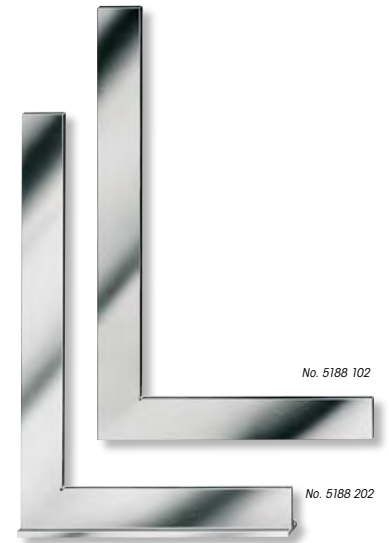

**Stellwinkel  
Stahlschmiege**

**Sliding T bevels  
Steel sliding bevel**



- ▶ Normalstahl verzinkt
- ▶ 3-teilig mit Schraubcharnier
- ▶ Lieferung einzeln verpackt

- ▶ Galvanised normal steel
- ▶ 3 parts hinged
- ▶ Delivered in individual packages

L mm	kg	Nº	L mm	kg	Nº
150	0,22	5197 202	300	0,5	5197 205
200	0,27	5197 203	400	0,67	5197 206
250	0,41	5197 204	500	0,8	5197 207



**Zimmermannswinkel**

**Carpenter's squares**



- ▶ Normalstahl verzinkt
- ▶ Lieferung einzeln verpackt

- ▶ Galvanised normal steel
- ▶ Delivered in individual packages

**5201 1.. :**  
ohne Anreißlöcher

**5201 1.. :**  
Without marking holes

**5201 2.. :**  
mit Anreißlöcher

**5201 2.. :**  
With marking holes

L mm	kg	Nº	kg	Nº
600 x 280	0,39	5201 102	0,36	5201 202
700 x 300	0,46	5201 103	0,43	5201 203
800 x 320	0,51	5201 104	0,48	5201 204
1000 x 380	0,7	5201 106	0,67	5201 206

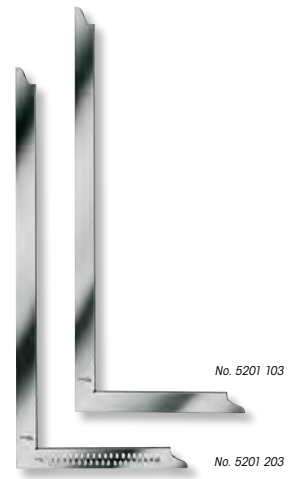

**Flanschenwinkel**

**Flange squares**



- ▶ Normalstahl verzinkt
- ▶ Lieferung einzeln verpackt

- ▶ Galvanised normal steel
- ▶ Delivered in individual packages

L mm	kg	Nº	L mm	kg	Nº
300 x 300	0,67	5198 201	600 x 600	1,6	5198 204
400 x 400	1,2	5198 202	800 x 800	2,1	5198 205
500 x 500	1,35	5198 203			

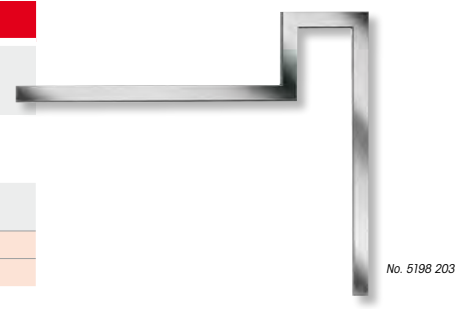

1  
2  
3  
4  
5  
6  
7  
8  
9  
10  
11  
12  
13  
14  
15

## Schreinerwinkel

## Joiner's squares



- ▶ Druckgusschenkel mit Gehrung
- ▶ Stahlzunge
- ▶ Lieferung einzeln verpackt

- ▶ Die cast blade with mitre
- ▶ steel blade
- ▶ Delivered in individual packages

### 5206 3.. :

Stahlzunge 30mm, Teilung mm/inch

### 5206 3.. :

Steel blade 30mm, mm/inch graduation

### 5206 4.. :

Stahlzunge 35mm, schwere Ausführung, Teilung mm/mm

### 5206 4.. :

Steel blade 35mm, solid model, mm/mm graduation

ℓ mm	kg	Nº	kg	Nº
200	0,08	5206 302	0,16	5206 402
250	0,1	5206 303	0,19	5206 403
300	0,11	5206 304	0,21	5206 404
400	0,13	5206 305	0,23	5206 405

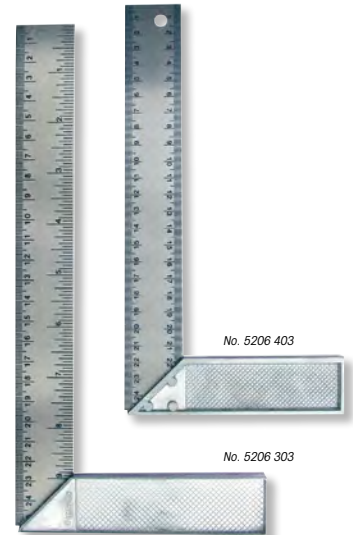

## Stellwinkel Schreinerschmiege

## Sliding T bevels Joiner's sliding bevel



- ▶ Druckgusschenkel
- ▶ Stahlzunge
- ▶ Lieferung einzeln verpackt

- ▶ Die cast blade
- ▶ Steel blade
- ▶ Delivered in individual packages

ℓ mm	kg	Nº
200	0,16	5211 201
250	0,19	5211 202
300	0,21	5211 203



## Schreinerwinkel

## Joiner's squares



- ▶ Buchenholzchenkel mit Gehrung und Messingbeschlag
- ▶ blaue Stahlzunge Teilung mm/mm
- ▶ Lieferung einzeln verpackt

- ▶ Beech wood base with mitre and brass inlay
- ▶ mm/mm graduation on blue steel blade
- ▶ Delivered in individual packages

ℓ mm	kg	Nº
150	0,1	5205 201
200	0,13	5205 202
250	0,16	5205 203
300	0,19	5205 204
400	0,23	5205 205

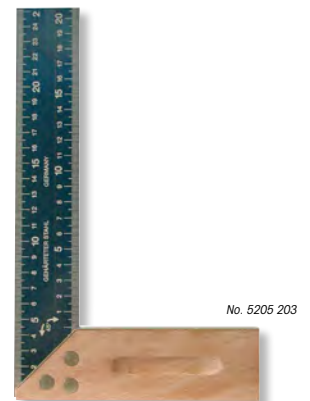

## Stellwinkel Schreinerschmiege

## Sliding T bevels Joiner's sliding bevel



- ▶ Buchenholzchenkel mit Messingbeschlag
- ▶ blaue Stahlzunge
- ▶ Lieferung einzeln verpackt

- ▶ Beech wood base with brass inlay
- ▶ Blue steel blade
- ▶ Delivered in individual packages

ℓ mm	kg	Nº
200	0,16	5211 101
250	0,19	5211 102
300	0,21	5211 103





## Digital-Winkelmesser

## Digital bevel protractors



- ▶ Werksnorm
- ▶ Sylvac System
- ▶ rostfreier Stahl gehärtet
- ▶ Feineinstellung
- ▶ Klemmung, Schiene verschiebbar
- ▶ großes LCD Display
- ▶ Ablesung 1' / 0,01°
- ▶ Genauigkeit ± 3'
- ▶ Messbereiche 360° / 180° / 90°
- ▶ Lieferung im Etui

### Funktion:

- ▶ Ein/Aus
- ▶ 1' / 0,01° Umschaltung
- ▶ Messbereichwahl
- ▶ 0-Punkt an jeder Position
- ▶ Reset
- ▶ Datenausgang Opto

- ▶ Works standard
- ▶ Sylvac System
- ▶ Hardened stainless steel
- ▶ Fine adjustment
- ▶ Clamping and movable rule
- ▶ Large LCD display
- ▶ Reading 1' / 0.01°
- ▶ Accuracy ± 3'
- ▶ Measuring range 360° / 180° / 90°
- ▶ Delivered in a case

### Function:

- ▶ On/Off
- ▶ 1' / 0.01° Switchover
- ▶ Measuring range select
- ▶ Zero setting at any position
- ▶ Reset
- ▶ Data output Opto



No. 2000 102

l-  mm	kg	Nº
150	0,36	2000 101
200	0,37	2000 102
300	0,38	2000 103
500	0,39	2000 104
Datenkabel RS232 (2m) / Data cable RS232 (2m)		1850 203
Datenkabel USB (2m) / Data cable USB (2m)		1850 204

## Digital-Winkelmesser STANDARD

## Digital bevel protractors STANDARD



- ▶ Werksnorm
- ▶ rostfreier Stahl gehärtet
- ▶ Feineinstellung
- ▶ Klemmung, Schiene verschiebbar
- ▶ großes, 2-zeiliges LCD Display:  
Ablesung oben: Dezimal-Grad  
Ablesung unten: Grad/Minuten/Sekunden
- ▶ Ablesung 1' / 0,01°
- ▶ Genauigkeit ± 5'
- ▶ Messbereiche 360° / 180° / 90°
- ▶ Lieferung im Etui inkl. 90° Einstellwinkel

### Funktion:

- ▶ Ein/Aus
- ▶ Ablesung 1' / 0.01°
- ▶ Messbereichwahl
- ▶ 0-Punkt an jeder Position
- ▶ Reset

- ▶ Works standard
- ▶ Hardened stainless steel
- ▶ Fine adjustment
- ▶ Clamping and movable rule
- ▶ Large 2-line LCD display:  
Upper reading: decimal-degree  
Lower reading: degree/minutes/seconds
- ▶ Reading 1' / 0.01°
- ▶ Accuracy ± 5'
- ▶ Measuring range 360° / 180° / 90°
- ▶ Delivered in a case incl. 90° setting square

### Function:

- ▶ On/Off
- ▶ Reading 1' / 0.01°
- ▶ Measuring range select
- ▶ Zero setting at any position
- ▶ Reset



No. 2000 151

l-  mm	kg	Nº
150 / 300	0,37	2000 151

## Winkelmesser mit Uhrablesung

## Bevel protractors with dial reading

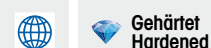

- ▶ Werksnorm
- ▶ rostfreier Stahl gehärtet
- ▶ Klemmung, Schiene verschiebbar
- ▶ Ablesung 5' 1/12°
- ▶ Messbereich 4x90°
- ▶ Lieferung im Etui

- ▶ Works standard
- ▶ Hardened stainless steel
- ▶ Clamping and movable rule
- ▶ Reading 5' 1/12°
- ▶ Measuring range 4x90°
- ▶ Delivered in a case



No. 2004 101

l-  mm	kg	Nº
150 / 200 / 300	0,5	2004 101

## Universal Winkelmesser mit Feineinstellung

## Universal bevel protractors with fine adjustment



- ▶ Werksnorm
- ▶ rostfreier Stahl gehärtet
- ▶ Ableseteile mattverchromt
- ▶ Klemmung, Schiene verschiebbar
- ▶ Ablesung parallaxfrei 5° / 1/12°
- ▶ Ableselupe
- ▶ Messbereich 4x90°
- ▶ Lieferung im Etui

- ▶ Works standard
- ▶ Hardened stainless steel
- ▶ Reading parts satin chrome
- ▶ Clamping and movable rule
- ▶ Parallax free reading 5° / 1/12°
- ▶ Magnifying glass
- ▶ Measuring range 4x90°
- ▶ Delivered in a case



No. 2006 102

l-  mm	kg	Nº
150	0,26	2006 101
200	0,27	2006 102
300	0,28	2006 103
500	0,3	2006 104

## Universal Winkelmesser STANDARD mit Feineinstellung

## Universal bevel protractors, STANDARD with fine adjustment



- ▶ Werksnorm
- ▶ rostfreier Stahl gehärtet
- ▶ Ableseteile mattverchromt
- ▶ Klemmung, Schiene verschiebbar
- ▶ Ablesung parallaxfrei 5° / 1/12°
- ▶ Ableselupe
- ▶ Messbereich 4x90°
- ▶ Lieferung im Etui

- ▶ Works standard
- ▶ Hardened stainless steel
- ▶ Reading parts satin chrome
- ▶ Clamping and movable rule
- ▶ Parallax free reading 5° / 1/12°
- ▶ Magnifying glass
- ▶ Measuring range 4x90°
- ▶ Delivered in a case



No. 5223 203

l-  mm	kg	Nº
150 / 200 / 300	0,5	5223 203

## Zubehör für Universal Winkelmesser

## Accessories for universal bevel protractors



- ▶ Passend für Modelle Nr. 2000 1.. und Nr. 2006 1..
- ▶ Lieferung einzeln verpackt

- ▶ Suitable for models No. 2000 1... and No. 2006 1...
- ▶ Delivered in individual packages

Typ Type	l-  mm	kg	Nº
Winkelanschlag Attachment square	75	0,09	5221 101
Fuß mit Prisma V base	-	0,23	5222 101

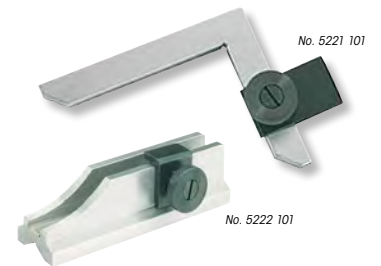

No. 5221 101

No. 5222 101

## Kombinations-Winkelmesser

## Combination squares



- ▶ Verwendbar als Winkelmesser, Lineal, Maßstab, Anschlag, Zentrier- und Gehrungswinkel sowie als Richtwaage.
- ▶ Winkelmesser 2x90°
- ▶ Schiene mit Teilung 1/1mm 1/2mm 1/64" 1/32"
- ▶ Lieferung einzeln verpackt

- ▶ Usable as bevel protractor, straightedge, rule, back, centres and mitre squares and as spirit level.
- ▶ Bevel protractor 2 x 90°
- ▶ Rule with graduation 1/1mm 1/2mm 1/64" 1/32"
- ▶ Delivered in individual packages



No. 5229 402

l-  mm	kg	Nº
300	0,8	5229 402

## Digital-Gradmesser

## Digital protactors



TOP

- ▶ rostfreier Stahl
- ▶ Feststellschraube
- ▶ Ablesung 0,05°
- ▶ Messbereich 0 – 180°
- ▶ Genauigkeit ± 0,3°
- ▶ Lieferung in Kunstledertasche

### Funktion:

- ▶ Ein/Aus, 0-Punkt an jeder Position, Hold Funktion
- ▶ Digital-Anzeige um 180° drehbar

- ▶ Stainless steel
- ▶ Locking screw
- ▶ Reading 0.05°
- ▶ Measuring range 0 – 180°
- ▶ Accuracy ± 0.3°
- ▶ Delivered in imitation leather bag

### Functions:

- ▶ On/Off, Zero setting at any position, Hold function
- ▶ Digital-Display 180° turnable

Ø-mm	L-mm	kg	Nº
120	150	0,26	5225 201
150	200	0,31	5225 202
200	300	0,45	5225 203

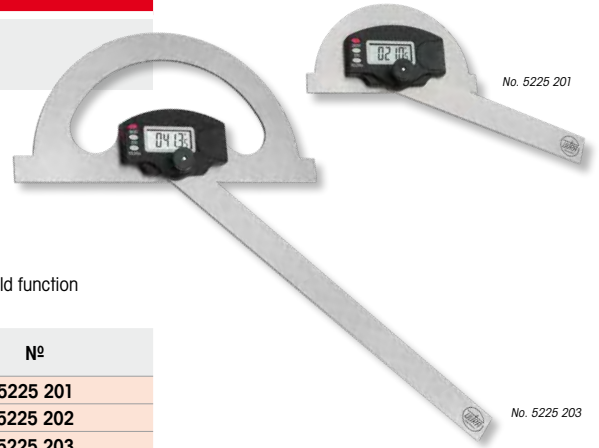

## Gradmesser

## Protractors



TOP

- ▶ Normalstahl mattverchromt
- ▶ Feststellschraube
- ▶ Ablesung 1°
- ▶ Messbereich 0 – 180°
- ▶ Lieferung einzeln verpackt

- ▶ Satin chrome normal steel
- ▶ Locking screw
- ▶ Reading 1°
- ▶ Measuring range 0 – 180°
- ▶ Delivered in individual packages

Ø-mm	L-mm	kg	Nº
80	120	0,06	5226 201
120	150	0,13	5226 202
150	200	0,19	5226 203
200	300	0,34	5226 204

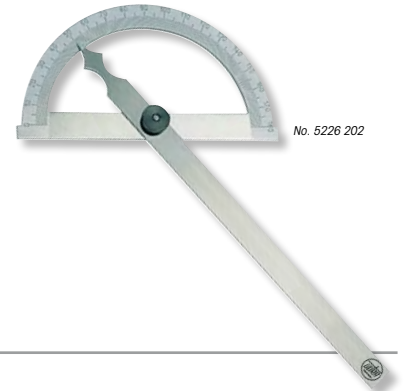

## Gradmesser, mit verschiebbarer Schiene

## Protractors, with movable rule



TOP

- ▶ Normalstahl mattverchromt
- ▶ Feststellschraube
- ▶ Ablesung 1°
- ▶ Messbereich 10 – 170°
- ▶ Lieferung einzeln verpackt

- ▶ Satin chrome normal steel
- ▶ Locking screw
- ▶ Reading 1°
- ▶ Measuring range 10 – 170°
- ▶ Delivered in individual packages

Ø-mm	L-mm	kg	Nº
100	150	0,11	5228 201
150	300	0,25	5228 202
200	400	0,42	5228 203
250	500	1,0	5228 204
300	600	1,35	5228 205

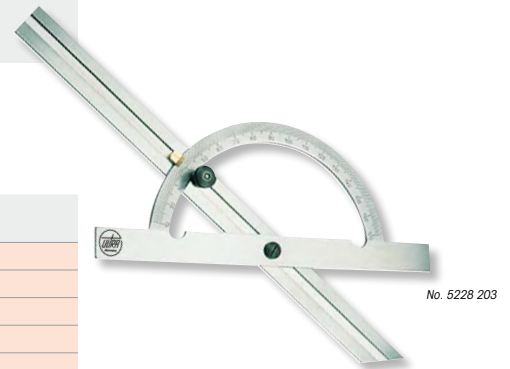

## Gradmesser, amerikanische Bauart

## Protractors, American design



- ▶ Normalstahl mattverchromt
- ▶ Feststellschraube
- ▶ Ablesung 1°
- ▶ Messbereich 0 – 180°
- ▶ Lieferung einzeln verpackt

- ▶ Satin chrome normal steel
- ▶ Locking screw
- ▶ Reading 1°
- ▶ Measuring range 0 – 180°
- ▶ Delivered in individual packages

5227 201 :

Gradbogen rund

5227 201 :

Graduated arc, round

5227 202 :

Gradbogen eckig

5227 202 :

Graduated arc, angular

Ø-mm	L-mm	kg	Nº
85	150	0,08	5227 201
85	150	0,09	5227 202

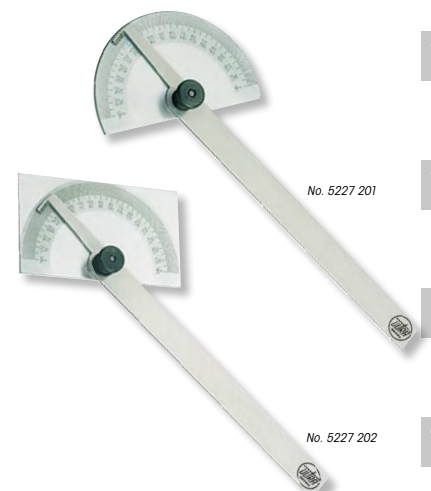

## MICROLEVEL Richtwaagen Horizontalmodell



- ▶ Werksnorm
- ▶ Basis aus Spezialguss
- ▶ Handwärmeschutz
- ▶ 1 prismatische Sohle
- ▶ Querlibelle
- ▶ großes LCD Display
- ▶ Lieferung im Holzetui

### Funktionen:

- ▶ Ein/Aus
- ▶ Empfindlichkeit wählbar L1 oder L2
- ▶ Ablesung umschaltbar
- ▶ O-Punkt an jeder Position
- ▶ Datenausgang

! Modelle mit flacher Sohle und Magneten auf Anfrage.

## MICROLEVEL precision levels Horizontal model

- ▶ Works standard
- ▶ Special cast iron base
- ▶ Insulated pads
- ▶ 1 V base
- ▶ Lateral vial
- ▶ Large LCD display
- ▶ Delivered in a wooden case

### Functions:

- ▶ On/Off
- ▶ Selectable sensitivity L1 or L2
- ▶ Reversible reading
- ▶ Zero setting at any position
- ▶ Data output

! Models with flat bases and magnets on request.

A mm	B mm	L1 mm/m	L2 mm/m	h kg	Nº
200	44	0,01	0,001	2,3	1701 102
200	44	0,05	0,005	2,3	1701 103

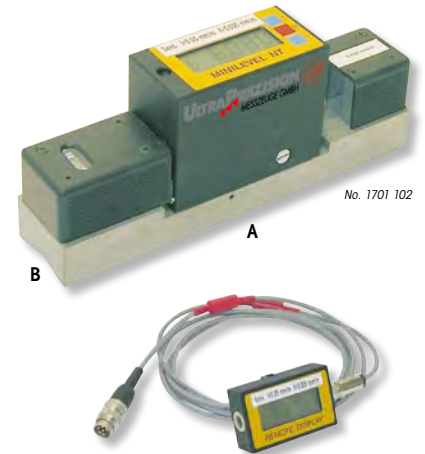

Option: Separates Display zum Messen an schwer zugänglichen Stellen.  
Option: Separate display for measuring on difficult reachable places.

## MICROLEVEL Richtwaagen Winkelmodell



- ▶ Werksnorm
- ▶ Rahmen aus Spezialguss
- ▶ Handwärmeschutz
- ▶ 2 prismatische Flächen
- ▶ Querlibelle
- ▶ großes LCD Display
- ▶ Lieferung im Holzetui

### Funktionen:

- ▶ siehe Horizontalmodell Nr. 1701 1..

! Modelle mit flachen Seiten und Magneten auf Anfrage.

## MICROLEVEL precision levels Square model

- ▶ Works standard
- ▶ Special cast iron frame
- ▶ Insulated pads
- ▶ 2 V faces
- ▶ Lateral vial
- ▶ Large LCD display
- ▶ Delivered in a wooden case

### Functions:

- ▶ See horizontal model No. 1701 1..

! Models with flat sides and magnets on request.

A mm	B mm	L1 mm/m	L2 mm/m	h kg	Nº
200 x 200	42	0,01	0,001	4,0	1702 102
200 x 200	42	0,05	0,005	4,0	1702 103

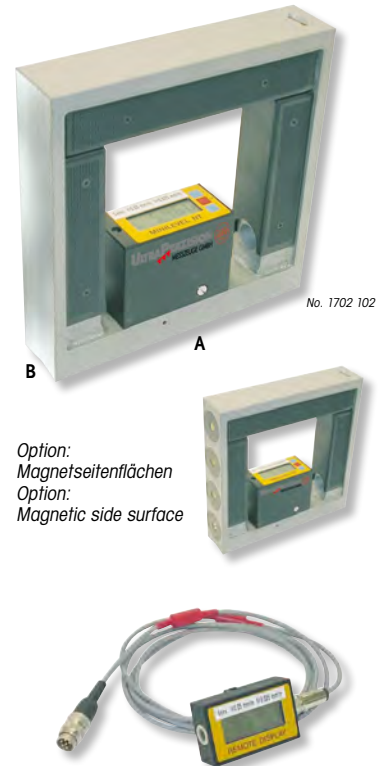



Option:  
Magnetseitenflächen  
Option:  
Magnetic side surface

Option: Separates Display zum Messen an schwer zugänglichen Stellen.  
Option: Separate display for measuring on difficult reachable places.

**μLevel Neigungsmesssystem,  
ohne Bluetooth-Funktion**

**μLevel spirit level,  
without Bluetooth-Function**

  **TOP**

- ▶ Werksnorm
- ▶ Basis aus Spezialguss
- ▶ großes LCD Display
- ▶ interner Datenspeicher
- ▶ Lieferung im Koffer

- ▶ Works standard
- ▶ Special cast iron base
- ▶ Large LCD display
- ▶ Internal memory
- ▶ Delivered in a box

- Funktionen:**
- ▶ Ein/Aus
  - ▶ Empfindlichkeit wählbar L1 oder L2
  - ▶ 0-Punkt an jeder Position
  - ▶ Datenausgang

- Functions:**
- ▶ On/Off
  - ▶ Selectable sensitivity L1 or L2
  - ▶ Zero setting at any position
  - ▶ Data output



A mm	B mm	L1 mm/m	L2 mm/m	kg	Nº
150	40	0,01	0,001	1,5	1705 101



No. 1705 101

**μLevel Neigungsmesssystem,  
mit Bluetooth-Funktion**

**μLevel spirit level,  
with Bluetooth-Function**

   **Bluetooth®**

- ▶ Werksnorm
- ▶ Basis aus Spezialguss
- ▶ großes LCD Display
- ▶ interner Datenspeicher
- ▶ Lieferung im Koffer

- ▶ Works standard
- ▶ Special cast iron base
- ▶ Large LCD display
- ▶ Internal memory
- ▶ Delivered in a box

- Funktionen:**
- ▶ Ein/Aus
  - ▶ Empfindlichkeit wählbar L1 oder L2
  - ▶ 0-Punkt an jeder Position
  - ▶ Datenausgang

- Functions:**
- ▶ On/Off
  - ▶ Selectable sensitivity L1 or L2
  - ▶ Zero setting at any position
  - ▶ Data output

- Inhalt:**
- ▶ μLevel Neigungsmesssystem
  - ▶ μLevel externes Display (107x59x13mm) Motorola Defy BT WI-FI 3.7" Display (oder vergleichbar)
  - ▶ Fernanzeige-Software für das μLevel auf Android Basis
  - ▶ USB Micro Twist, 4 GB

- Contents:**
- ▶ μLevel spirit level
  - ▶ μLevel remote display (107x59x13mm) Motorola Defy BT WI-FI 3.7" Display (or similar)
  - ▶ Software for remote display for the μLevel based on Android
  - ▶ USB Micro Twist, 4 GB

A mm	B mm	L1 mm/m	L2 mm/m	kg	Nº
150	40	0,01	0,001	1,5	1705 201



No. 1705 201

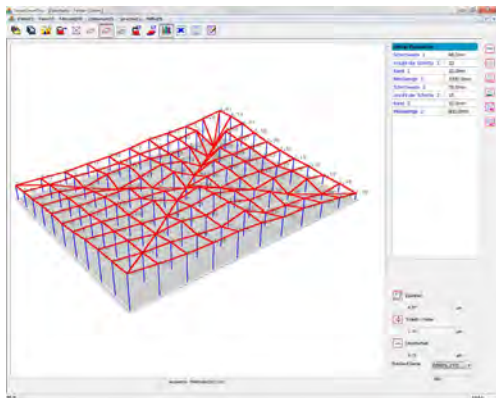

Software für Fernanzeige auf Android-Basis.  
Die Software verbindet sich mit bis zu 2 μLevel Geräten gleichzeitig. Hier können die aktuellen Messwerte angezeigt, genullt oder als Differenzwert dargestellt werden. Weiterhin ist eine nachgebildete Analoganzeige verfügbar. Neben den reinen Anzeigen können Werte als Grafik aufgezeichnet werden.

Software for remote display based on Android.  
The software can be connected with up to 2 μLevel instruments at the same time. Here the current measuring values can be displayed, set at zero or represented as difference value. Furthermore an analog representation on the display is also possible. The values can be recorded in numerical form but also shown as graphic chart.



Als externes Display bieten wir ein Smartphone auf Android-Basis an. Das Gerät kann ohne SIM-Karte als Anzeige genutzt werden.

As remote display we offer a smartphone based on Android. The instrument can be used as display, without SIM card.

## Richtwaagen mit Feinverstellung Horizontalmodell

## Engineer's levels with fine adjustment Horizontal model



**Gehärtet  
Hardened**

- ▶ DIN 877
- ▶ Basis aus Spezialguss, gehärtet
- ▶ 1 prismatische Sohle
- ▶ Längs- und Querlibelle
- ▶ Verstellbereich  $\pm 10\text{mm/m}$
- ▶ Ablesung  $0,05\text{mm/m}$
- ▶ Lieferung im Holzetui

$\triangleleft \leq$  = Empfindlichkeit mm/m

A mm	B mm	kg	$\triangleleft \leq 0,01$ Nº	$\triangleleft \leq 0,02$ Nº
140	40	1,2	1715 101	1715 201
200	40	1,7	1715 102	1715 202
300	40	2,7	1715 103	1715 203

- ▶ DIN 877
- ▶ Hardened special cast-iron base
- ▶ 1 V base
- ▶ Longitudinal and lateral vials
- ▶ Adjustment range  $\pm 10\text{mm/m}$
- ▶ Reading  $0.05\text{mm/m}$
- ▶ Delivered in a wooden case

$\triangleleft \leq$  = Sensitivity mm/m

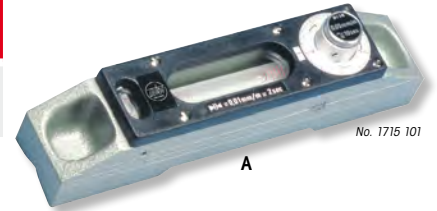

B

Feinverstellung  
Fine adjustment



## Richtwaagen mit Feinverstellung Winkelmodell

## Engineer's levels with fine adjustment Square frame



**Gehärtet  
Hardened**

- ▶ DIN 877
- ▶ Rahmen aus Spezialguss, gehärtet
- ▶ Handwärmeschutz
- ▶ 4 Messflächen, 2 mit Prisma
- ▶ Längs- und Querlibelle
- ▶ Verstellbereich  $\pm 10\text{mm/m}$
- ▶ Ablesung  $0,05\text{mm/m}$
- ▶ Lieferung im Holzetui

$\triangleleft \leq$  = Empfindlichkeit mm/m

A mm	B mm	kg	$\triangleleft \leq 0,01$ Nº	$\triangleleft \leq 0,02$ Nº
200x200	40	4,0	1716 101	1716 201
300x300	40	8,8	1716 102	1716 202

- ▶ DIN 877
- ▶ Hardened special cast-iron frame
- ▶ Insulated pads
- ▶ 4 measuring faces, 2 with V-grooves
- ▶ Longitudinal and lateral vials
- ▶ Adjustment range  $\pm 10\text{mm/m}$
- ▶ Reading  $0.05\text{mm/m}$
- ▶ Delivered in a wooden case

$\triangleleft \leq$  = Sensitivity mm/m

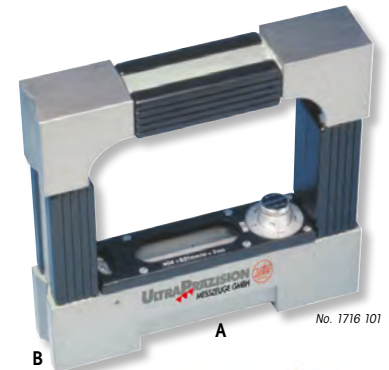

B

Feinverstellung  
Fine adjustment



## Clinometer mit Feinverstellung

## Clinometer with fine adjustment



**Gehärtet  
Hardened**

- ▶ Werksnorm
- ▶ Meßfläche gehärtet, mit Prisma
- ▶ Skaleneinstellung  $\pm 180^\circ$
- ▶ Skalablesung  $1^\circ$ , Mikrometerablesung  $1'$
- ▶ Empfindlichkeit  $0,3\text{mm/m}$
- ▶ Lieferung im Holzetui

! magnetische Sohle 120x30mm sowie Einspannschaft auf Anfrage.

- ▶ Works standard
- ▶ Hardened measuring face with V
- ▶ Scale adjustment  $\pm 180^\circ$
- ▶ Scale reading  $1^\circ$ , Micrometer reading  $1'$
- ▶ Sensitivity  $0.3\text{mm/m}$
- ▶ Delivered in a wooden case

! Magnetic base 120 x 30mm and clamping shaft on request.

L mm	kg	Nº
150x30x124	2,0	1730 101

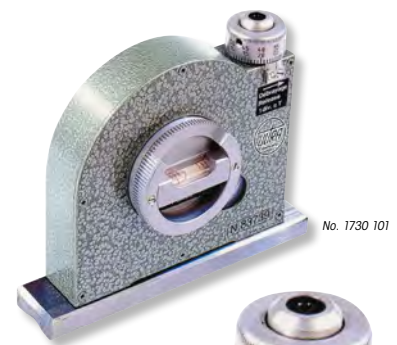



Feinverstellung  
Fine adjustment



**Richtwaagen  
Horizontalmodell**

**Engineer's levels  
Horizontal model**

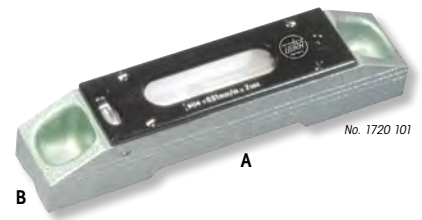

- ▶ DIN 877
- ▶ Basis aus Spezialguss, gehärtet
- ▶ 1 prismatische Sohle
- ▶ Längs- und Querlibelle
- ▶ Lieferung im Holzetui

- ▶ DIN 877
- ▶ Hardened special cast-iron base
- ▶ 1 V base
- ▶ Longitudinal and lateral vials
- ▶ Delivered in a wooden case

◀ = Empfindlichkeit mm/m

◀ = Sensitivity mm/m

! Richtwaagen für große Wellen-Ø auf Anfrage.

! Levels for large shaft-Ø on request.

A mm	B mm	kg	◀ 0,1 N°	◀ 0,05 N°	◀ 0,04 N°	◀ 0,02 N°	◀ 0,01 N°
140	40	1,2	1720 101	1721 101	1722 101	1723 101	1724 101
200	40	1,5	1720 102	1721 102	1722 102	1723 102	1724 102
300	40	2,4	1720 103	1721 103	1722 103	1723 103	1724 103
500	40	4,3	1720 104	1721 104	1722 104	1723 104	1724 104

**Richtwaagen  
Winkelmodell**

**Engineer's levels  
Square frame**





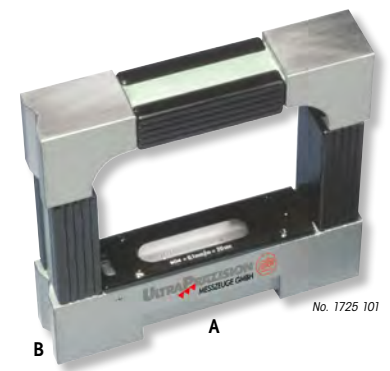

- ▶ DIN 877
- ▶ Rahmen aus Spezialguss, gehärtet
- ▶ Handwärmeschutz
- ▶ 4 Messflächen, 2 mit Prisma
- ▶ Längs- und Querlibelle
- ▶ Lieferung im Holzetui

- ▶ DIN 877
- ▶ Hardened special cast-iron frame
- ▶ Insulated pads
- ▶ 4 measuring faces, 2 with V-grooves
- ▶ Longitudinal and lateral vials
- ▶ Delivered in a wooden case

◀ = Empfindlichkeit mm/m

◀ = Sensitivity mm/m

! Richtwaagen für große Wellen-Ø auf Anfrage.

! Levels for large shaft-Ø on request.

A mm	B mm	kg	◀ 0,1 N°	◀ 0,05 N°	◀ 0,04 N°	◀ 0,02 N°	◀ 0,01 N°
200x200	40	3,8	1725 101	1726 101	1727 101	1728 101	1729 101
300x300	40	8,5	-	1726 102	1727 102	1728 102	1729 102

**Richtwaagen für Kurbelzapfen**

**Crankpin levels**



- ▶ DIN 877
- ▶ Basis aus Spezialguss
- ▶ Handwärmeschutz
- ▶ Messfläche mit Längs- und Querprisma
- ▶ Längs- und Querlibelle
- ▶ Lieferung einzeln verpackt

- ▶ DIN 877
- ▶ Special cast-iron base
- ▶ Insulated pads
- ▶ Measuring faces with longitudinal and lateral V-s
- ▶ Longitudinal and lateral vials
- ▶ Delivered in individual packages

◀ = Empfindlichkeit mm/m

◀ = Sensitivity mm/m

1760 1.. :  
Holzetui

1760 1.. :  
Wooden box

! Andere Empfindlichkeiten auf Anfrage.

! Other sensitivities on request.

A mm	B mm	kg	◀ 0,4 N°	◀ 0,1 N°	N°
60	40	0,4	1756 101	1758 101	1760 101
90	40	0,6	1756 102	1758 102	1760 102
120	40	0,8	1756 103	1758 103	1760 103

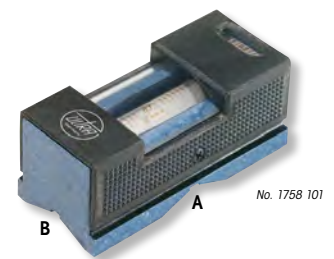

## Richtwaagen STANDARD Horizontalmodell

## Engineer's levels, STANDARD Horizontal model



TOP

- ▶ DIN 877
- ▶ Basis aus Spezialguss
- ▶ Handwärmeschutz
- ▶ 1 prismatische Sohle
- ▶ Längs- und Querlibelle
- ▶ Lieferung einzeln verpackt

◀ε = Empfindlichkeit mm/m

- ▶ DIN 877
- ▶ Special cast-iron base
- ▶ Insulated pads
- ▶ 1 V base
- ▶ Longitudinal and lateral vials
- ▶ Delivered in individual packages

◀ε = Sensitivity mm/m

1750 1.. :

Holzzeit

1750 1.. :

Wooden box

! Richtwaagen für große Wellen-Ø oder mit magnetischen Flächen auf Anfrage.

! Levels for large shaft-Ø or with magnetic surfaces on request.

A mm	B mm	h kg	◀ε 0,3 №	◀ε 0,1 №	◀ε 0,04 №	◀ε 0,02 №	◀ε 0,01 №	№
160	42	1,1	1740 101	1741 101	1742 101	1743 101	1744 101	1750 101
200	42	1,4	1740 102	1741 102	1742 102	1743 102	1744 102	1750 102
250	42	1,7	1740 103	1741 103	1742 103	1743 103	1744 103	1750 103
300	51	2,3	1740 104	1741 104	1742 104	1743 104	1744 104	1750 104
500	51	4,9	1740 105	1741 105	1742 105	1743 105	1744 105	1750 105

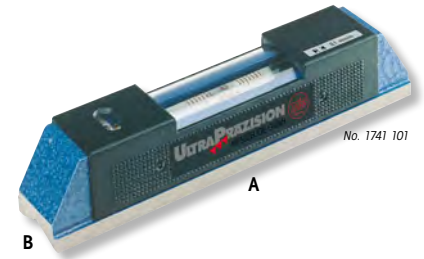

No. 1741 101



No. 1750 101

## Richtwaagen STANDARD Winkelmodell

## Engineer's levels, STANDARD Square frame



TOP

- ▶ DIN 877
- ▶ Rahmen aus Spezialguss
- ▶ Handwärmeschutz
- ▶ 4 Messflächen, 3 mit Prisma
- ▶ Längs- und Querlibelle
- ▶ Lieferung einzeln verpackt

◀ε = Empfindlichkeit mm/m

- ▶ DIN 877
- ▶ Special cast-iron frame
- ▶ Insulated pads
- ▶ 4 measuring faces, 3 with V grooves
- ▶ Longitudinal and lateral vials
- ▶ Delivered in a case

◀ε = Sensitivity mm/m

1751 1.. :

Holzzeit

1751 1.. :

Wooden box

! Richtwaagen für große Wellen-Ø oder mit magnetischen Flächen auf Anfrage.

! Levels for large shaft-Ø or with magnetic faces on request.

A mm	B mm	h kg	◀ε 0,3 №	◀ε 0,1 №	◀ε 0,04 №	◀ε 0,02 №	◀ε 0,01 №	№
100x100	27	0,8	1745 101	1746 101	1747 101	-	-	1751 101
150x150	35	2,0	1745 102	1746 102	1747 102	1748 102	1749 102	1751 102
200x200	40	3,8	1745 103	1746 103	1747 103	1748 103	1749 103	1751 103
300x300	55	7,9	1745 104	1746 104	1747 104	1748 104	1749 104	1751 104

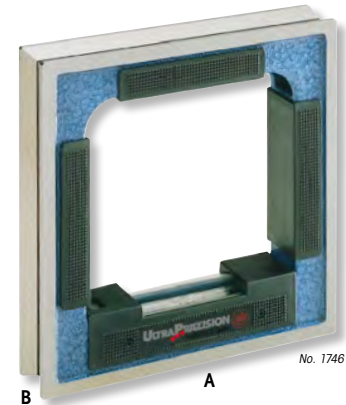

No. 1746 102



No. 1751 102



**Richtwaagen aus Aluminium**

**Aluminium levels**



- ▶ Werksnorm
- ▶ 1 prismatische Sohle
- ▶ 1 Längslibelle
- ▶ Empfindlichkeit 0,6mm/m
- ▶ Lieferung einzeln verpackt

- ▶ Works standard
- ▶ 1 V base
- ▶ 1 longitudinal vial
- ▶ Sensitivity 0.6mm/m
- ▶ Delivered in individual packages

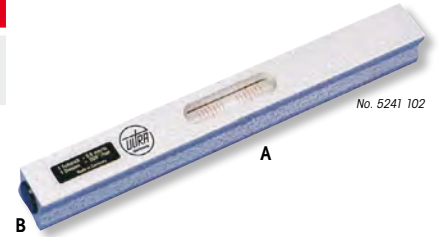

A mm	B mm	kg	Nº	A mm	B mm	kg	Nº
150	27	0,12	5241 102	250	27	0,21	5241 104
200	27	0,16	5241 103	300	27	0,24	5241 105

**Digital-Neigungsmesser**

**Digital protractor (clinometer)**



- ▶ Werksnorm
- ▶ Aluminiumgehäuse
- ▶ großes LCD-Display
- ▶ 1 prismatische Sohle
- ▶ Messbereich 360° (4x90°)
- ▶ Lieferung im Holzetui

- ▶ Works standard
- ▶ Aluminium housing
- ▶ Large LCD display
- ▶ 1 V base
- ▶ Measuring range 360° (4x90°)
- ▶ Delivered in a wooden case



- Funktion:
- ▶ 0-Punkt an jeder Position
  - ▶ HOLD Funktion
  - ▶ RESET und Eigenkalibriermodus

- Funktion:
- ▶ Zero setting at any position
  - ▶ HOLD function
  - ▶ RESET and self calibration mode

1704 1.. :  
Ablesung 0,1°

1704 1.. :  
Reading 0.1°

1704 2.. :  
Ablesung 0,01° mit Datenausgang

1704 2.. :  
Reading 0.01° with data output

mm	°	°	°	kg	Nº
150x30x54	0,1°	0 – 90°	0 – 10° / ± 0,1° 10 – 80° / ± 0,2° 80 – 90° / ± 0,1°	0,3	1704 101
150x30x54	0,01° 0,1°	0 – 9,99° 10 – 90°	0 – 10° / ± 0,05 10 – 80° / ± 0,2° 80 – 90° / ± 0,1°	0,3	1704 201

**Winkellehre magnetisch**

**Angle finder, magnetic**



- ▶ Werksnorm
- ▶ mit Mittelpunktkörner
- ▶ magnetischer Basis 90°
- ▶ Skala 360°
- ▶ Lieferung im einzeln verpackt

- ▶ Works standard
- ▶ With centre punch
- ▶ Magnetic base 90°
- ▶ Scale 360°
- ▶ Delivered in individual packages



kg	Nº
0,8	5204 101

1  
2  
3  
4  
5  
6  
7  
8  
9  
10  
11  
12  
13  
14  
15

## Winkel-Richtwaagen

## Angle finder levels



- ▶ Werksnorm
- ▶ Rahmen aus Spezialguss
- ▶ 2 Messflächen mit Prisma
- ▶ 1 Längslibelle
- ▶ Empfindlichkeit 0,3mm/m
- ▶ mattverchromte Skala 0 – 90°
- ▶ Noniusablesung 10'
- ▶ Feineinstellung
- ▶ Lieferung im Holzetui

- ▶ Works standard
- ▶ Special cast-iron frame
- ▶ 2 measuring faces with V-groove
- ▶ 1 longitudinal vial
- ▶ Sensitivity 0.3mm/m
- ▶ Satin chrome scale 0 – 90°
- ▶ Vernier reading 10'
- ▶ Fine adjustment
- ▶ Delivered in a wooden case



No. 5243 101

**5243 1.. :**

2 prismatische Messflächen

**5243 1.. :**

2 V measuring faces

**5243 2.. :**

2 flache magnetische Messflächen

**5243 2.. :**

2 flat magnetic measuring faces

L mm	h kg	Nº
150x150x39	1,85	<b>5243 101</b>
150x150x39	1,85	<b>5243 201</b>

## Gradwasserwaage

## Angle finder levels



- ▶ Werksnorm
- ▶ flache Sohle mit 2 Befestigungsbohrungen
- ▶ drehbare runde Skala mit Libelle
- ▶ Messbereich 4x90°
- ▶ Genauigkeit 1°
- ▶ Lieferung im Holzetui

- ▶ Works standard
- ▶ Flat base with 2 fixture holes
- ▶ Turnable round scale with vial
- ▶ Measuring range 4 x 90°
- ▶ Accuracy 1°
- ▶ Delivered in a wooden case



No. 5244 101

L mm	Ø mm	h kg	Nº
300 x 25	70	1,1	<b>5244 101</b>

## Neigungs-Richtwaage

## Angle finder levels



- ▶ aus Aluminium-Druckguss
- ▶ 1 prismatische Sohle
- ▶ drehbarer Libellenträger
- ▶ Lieferung im Holzetui

- ▶ Aluminium die cast
- ▶ 1 V base
- ▶ Turnable vial holder
- ▶ Delivered in a wooden case

# BMI®



No. 5246 101

L mm	∠	∠	h kg	Nº
500 x 27	2x90° 2x100%	1° 5%	1,47	<b>5246 101</b>

## Digital-Wasserwaagen

## Digital spirit levels



★ **NEW**

- ▶ Aluprofil pulverbeschichtet
- ▶ großes LCD-Display
- ▶ Horizontal- und Vertikallibelle
- ▶ Lieferung einzeln verpackt

### Funktionen:

- ▶ Ein/Aus
- ▶ Ablesung umschaltbar 0,1° / 0,1% / 0,1mm/m
- ▶ HOLD Funktion
- ▶ zuschaltbares akustisches Signal bei 0°- oder 90°

- ▶ Powder-coated aluminium profile
- ▶ Large LCD display
- ▶ Horizontal and vertical vials
- ▶ Delivered in individual packages

### Functions:

- ▶ On/Off
- ▶ Reversible reading 0.1° / 0.1% / 0.1mm/m
- ▶ HOLD function
- ▶ Switchable audible signal at 0° or 90°



No. 5258 102

! Ausführung mit Lasermodule auf Anfrage.

! Version with laser module on request.

l-  cm	☉	⚖ kg	Nº
60	bei / at 0° und / and 90° ±0,05° bei / at 1° bis / up to 89° ±0,3°	1,22	5258 101
80		1,3	5258 102
120		1,5	5258 103

## Wasserwaagen

## Spirit levels



★ **NEW**

- ▶ stabiles Aluprofil
- ▶ bruchsihere Horizontal- und Vertikallibelle
- ▶ Lieferung einzeln verpackt

- ▶ Stable aluminium profile
- ▶ Break-proof horizontal and vertical vials
- ▶ Delivered in individual packages



No. 5264 302

5264 3.. :  
Standard

5264 3.. :  
Standard

5264 4.. :  
mit Haftmagneten

5264 4.. :  
With magnets

l-  cm	⚖ kg	Nº	Nº
40	0,38	5264 301	5264 401
50	0,44	5264 302	5264 402
60	0,52	5264 303	5264 403
80	0,7	5264 304	5264 404
100	0,85	5264 305	5264 405
120	1,0	5264 306	5264 406
150	1,5	5264 307	5264 407
200	1,9	5264 308	5264 408

Mit Haftmagneten  
With magnets



No. 5264 4..

## Wasserwaagen in Trapezform

## Spirit levels in trapezoidal shape



★ **NEW**

- ▶ Aluminium-Druckguss
- ▶ bruchsihere Horizontal- und Vertikallibelle
- ▶ Lieferung einzeln verpackt

- ▶ Aluminium die cast
- ▶ Break-proof horizontal and vertical vials
- ▶ Delivered in individual packages



No. 5265 103

l-  cm	⚖ kg	Nº
40	0,4	5265 101
50	0,52	5265 102
60	0,65	5265 103
80	0,9	5265 104

## Torpedo-Wasserwaagen

## Torpedo spirit levels



- ▶ ABS Kunststoffgehäuse
- ▶ bruchsichere Libellen 0° / 45° / 90°
- ▶ magnetische Unterseite
- ▶ Lieferung einzeln verpackt

- ▶ ABS plastic housing
- ▶ Break-proof vials 0° / 45° / 90°
- ▶ Magnetic bottom/underside
- ▶ Delivered in individual packages



No. 5250 101

l mm	h kg	Nº
220	0,2	5250 101

## Schlauch-Wasserwaagen

## Water level kit



- ▶ 2 Plexiglasröhren mit 1/2cm Teilung
- ▶ robuste Kunststoffarmatur
- ▶ Lieferung inkl. 10m Schlauch

- ▶ 2 plexiglas tubes with 1/2cm graduation
- ▶ Sturdy plastic fitting
- ▶ Delivery incl. 10m tube

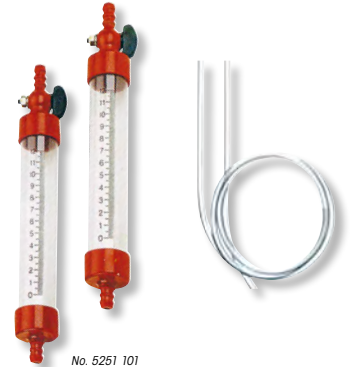

No. 5251 101

l mm	Ø mm	h kg	Nº
200	20	0,3	5251 101

## Nivelliertaster MODUS

## Levelling devices MODUS



- ▶ Einmannbedienung
- ▶ Nivellieren, Meterriss und Messen
- ▶ Wände, Ecken oder Säulen sind keine Hindernisse
- ▶ Messbereich ±20cm
- ▶ Ablesung millimetergenau
- ▶ Flüssigkeit verbleibt im Gerät
- ▶ Frostschutz bis -15°C
- ▶ Bauteile aus Edelstahl, Alu, Messing oder Kunststoff, dadurch korrosionsbeständig
- ▶ Lieferung im Transportkoffer, inkl. Schlauch, Messflüssigkeit 100ml und 500ml, Anreißwinkel

- ▶ One-man operation
- ▶ Levelling, marking and measuring
- ▶ Walls, corners or columns are no obstacles
- ▶ Measuring range ±20cm
- ▶ Millimetre-precise reading
- ▶ Liquid remains in the device
- ▶ Frost protection up to -15°C
- ▶ Corrosion-free due to stainless steel, aluminium, brass or plastic components,
- ▶ Delivered in transportation box incl. tube, measuring liquid 100ml and 500ml and marking square

! Messflüssigkeit sowie Ersatzteile auf Anfrage.

! Measuring liquid and spare parts on request.

Stativhöhe Stand height m	Arbeitsbereich Operating range m	Schlauchlänge Tube length m	h kg	Nº
1,4	40	20	13,0	5405 101



No. 5405 101

## Dosenlibellen und Präzisionslibellen

## Circular levels and precision vials



- ▶ verschiedene Empfindlichkeiten
- ▶ aus Glas oder Acryl
- ▶ in Metall oder Kunststoffgehäuse
- ▶ mit oder ohne Befestigungsbohrungen

- ▶ Wide range of sensitivities
- ▶ Glass and acrylic models
- ▶ Metal or plastic housing
- ▶ With or without fixture holes

! Bitte separates Prospekt anfordern.

! Please ask for separate brochure.

5255 1.. :

Dosenlibellen und Präzisionslibellen auf Anfrage.

5255 1.. :

Circular levels and precision vials on request.

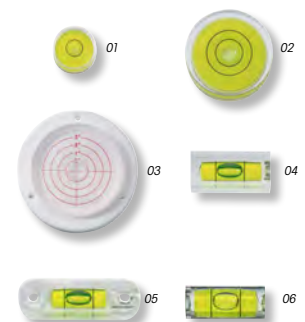

# 11

**Messschieber**  
Vernier calipers

**Tiefenmessschieber**  
Depth calipers

**Datenübertragung**  
Data transmission

**Großanzeigen LED**  
Large displays LED

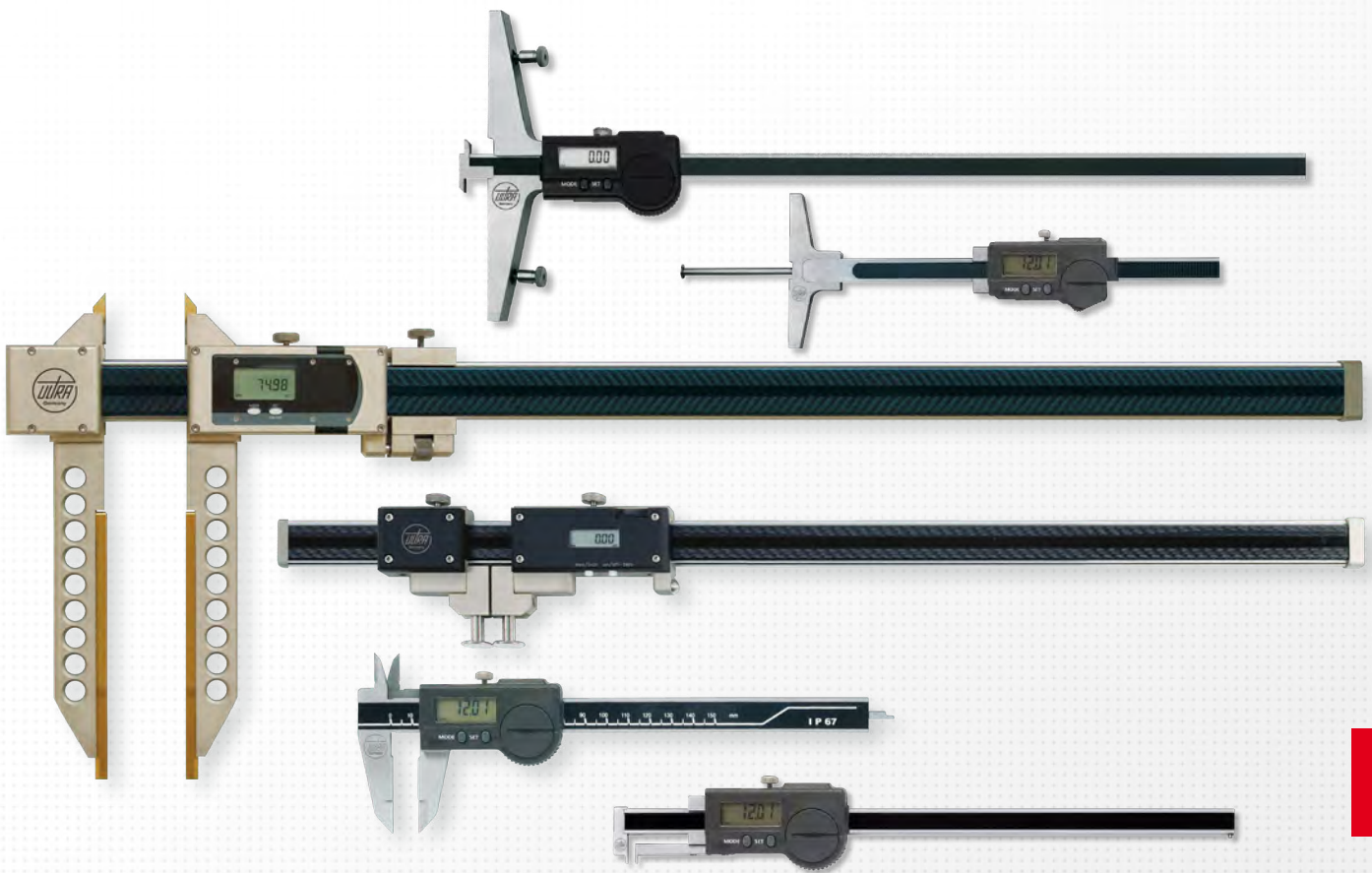

 **NEW**

**Digital-Universalmessschieber IP 67**  
Digital universal calipers IP 67



**Messschieber IP67, CABON**  
Calipers IP67, CARBON



**Digital-Universalmessschieber ALINOX**  
Digital universal calipers ALINOX



**Tiefenmessschieber CARBON**  
Depth calipers CARBON



## Messschieber nach DIN 862

Taschenmessschieber mit Tiefenmaß eignen sich zur 4-fach Messung gemäß unten stehenden Anwendungsbeispielen. Werkstattmessschieber haben abgesetzte und gerundete Messschnabelenden zur Innenmessung. Die Messerspitzen werden zur Messung in Nuten und Einstichen verwendet (siehe Abb.).

### Taschenmessschieber / Pocket calipers:

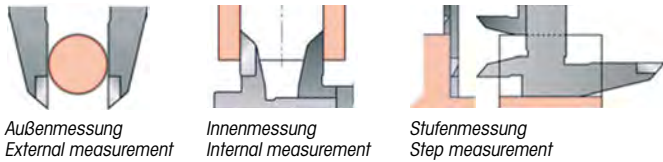

Außenmessung  
External measurement

Innenmessung  
Internal measurement

Stufenmessung  
Step measurement

Tiefenmessung  
Depth measurement

## Vernier calipers according to DIN 862

Pocket calipers with depth gauge are suitable for 4-way measurement, according to below mentioned examples of use. Workshop vernier calipers have split and rounded jaw ends (nibs) for internal measurement, the knife points are used for measuring in slots and grooves (see fig.).

### Werkstattmessschieber / Workshop calipers:

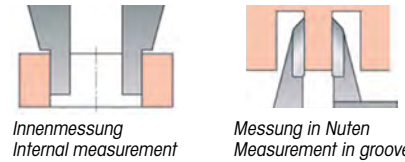

Innenmessung  
Internal measurement

Messung in Nuten  
Measurement in grooves

### Fehlergrenzen nach DIN 862

Die nach DIN festgelegten Fehlergrenzen (G) gelten für Messungen ohne Richtungswechsel der Messkraft. Bei Messungen mit Richtungswechsel und für Messungen mit dem Tiefenmaß erhöhen sich die Werte für Digitalmessschieber um 20µ, für Messschieber mit Rundskala oder Nonius gilt folgende Formel:  $G = (20 + l/10)\mu > 50\mu$

Werte A = Nonius 1/10mm oder 1/20mm :  $G = (20 + l/10)\mu$   
 Werte B = Nonius 1/50mm :  $G = (22 + l/50)\mu$   
 Werte C = Ablesung digital 0,01mm :  $G = (22 + l/50)\mu$

l mm	A (G)µ	B (G)µ	C (G)µ
50	50	20	20
100	50	30	30
200	50	30	30
300	50	30	30
400	60	30	30
500	70	30	30

### Error limits according to DIN 862

The error limits (G) specified according to DIN is applicable for measurements without change of direction of the measuring force. For measurements with change of direction and for measurements with the depth gauge, the values for digital calipers increase by 20µ; for calipers with round scale or vernier, the following formula is applicable:  $G = (20 + l/10)\mu > 50\mu$

Values A = Vernier 1/10mm or 1/20mm :  $G = (20 + l/10)\mu$   
 Values B = Vernier 1/50mm :  $G = (22 + l/50)\mu$   
 Values C = Digital reading 0.01mm :  $G = (22 + l/50)\mu$

l mm	A (G)µ	B (G)µ	C (G)µ
600	80	30	30
700	90	40	40
800	100	40	40
900	110	40	40
1000	120	40	40
1200	140	50	-

### Übersicht der IP Schutzarten nach DIN EN 60529 (angenähert)

(IP = International Protection)

Beispiel: IP67 = Staubdicht und gegen zeitweiliges Untertauchen in Wasser geschützt!

Schutz gegen Fremdkörper und Staub (1. Ziffer)		Schutz gegen Nässe (2. Ziffer)	
IP 1x	Fremdkörper >50mm	IP x1	Tropfwasser senkrecht
IP 2x	Fremdkörper >12,5mm	IP x2	Tropfwasser bis 15° Neigung
IP 3x	Fremdkörper >2,5mm	IP x3	Sprühwasser bis 60° Neigung
IP 4x	Fremdkörper >1,0mm	IP x4	Spritzwasser
IP 5x	Staubgeschützt	IP x5	Strahlwasser
IP 6x	Staubdicht	IP x6	starkes Strahlwasser
		IP x7	Zeitweiliges Untertauchen
		IP x8	Dauerndes Untertauchen

### Overview of the IP class according to DIN EN 60529 (approximated)

(IP = International Protection)

Example: IP 67 = dust-proof and protected from sporadic immersion in water!

Protection against impurities and dust (1 numeral)		Protection against moisture (2 numeral)	
IP 1x	Impurity > 50 mm	IP x1	Dripping water vertical
IP 2x	Impurity >12.5 mm	IP x2	Dripping water up to 15° incline
IP 3x	Impurity >2.5 mm	IP x3	Spray water up to 60° incline
IP 4x	Impurity >1.0 mm	IP x4	Spray water
IP 5x	Protected from dust	IP x5	Hose water
IP 6x	Dust-proof	IP x6	Strong hose water
		IP x7	Sporadic immersion
		IP x8	Continuous immersion

### Noniusablesung

Je nach Ausführung der Messschieber kommen folgende Varianten zum Einsatz:

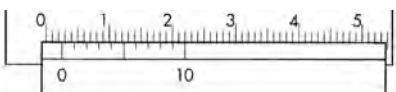

Nonius / Vernier - 1/10mm (0,1mm)

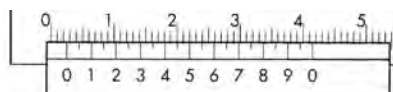

Nonius / Vernier - 1/20mm (0,05mm)

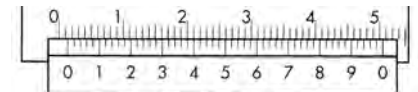

Nonius / Vernier - 1/50mm (0,02mm)

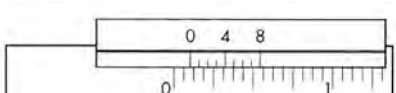

Nonius / Vernier - 1/128"

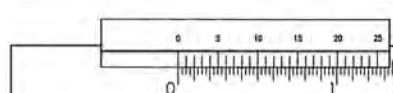

Nonius / Vernier - 1/1000"

### Vernier reading

According to the model of the calipers, the following versions are used:

## Digital-Taschenmessschieber, IP 67 Messflächen TIN beschichtet

## Digital pocket calipers, IP 67 TIN-coated measuring faces

 **IP67**

 **Gehärtet Hardened**



No. 1850 151tin

TIN beschichtet  
TIN coated

Mit großer 3V Batterie.  
With large 3V battery.



- ▶ DIN 862
- ▶ Schutzart IP 67, Sylvac System
- ▶ Feststellschraube
- ▶ rostfreier Stahl, gehärtet
- ▶ großes LCD Display
- ▶ Kreuzspitzen
- ▶ Tiefenmaß eckig
- ▶ 4-fach Messung
- ▶ Lieferung im Etui

**Funktionen:**

- ▶ Ein/Aus
- ▶ Auto-On bei Bewegung
- ▶ mm/inch Umschaltung
- ▶ 0-Punkt an jeder Position
- ▶ Lock Funktion (fester 0-Punkt), absolutes System
- ▶ Datenausgang Proximity

- ▶ DIN 862
- ▶ Protection class IP 67, Sylvac System
- ▶ Locking screw
- ▶ Hardened stainless steel
- ▶ Large LCD display
- ▶ Cross points
- ▶ Depth gauge angular
- ▶ 4-way measurement
- ▶ Delivered in a case

**Functions:**

- ▶ On/Off
- ▶ Auto-On by sliding
- ▶ mm/inch commutation
- ▶ Zero setting at any position
- ▶ Lock function (fixed 0 point), absolute system
- ▶ Data output Proximity

**1850 101tin :**  
Tiefenmaß rund Ø 1,5mm

**1850 101tin :**  
Round depth gauge Ø 1.5mm





**1850 151tin :**  
Tiefenmaß eckig

**1850 151tin :**  
Angular depth gauge

mm	inch	mm	mm	inch	kg	Nº	Nº
150	6	47	0,01	.0005	0,18	1850 101tin	1850 151tin
Datenkabel RS232 (2m) / Data cable RS232 (2m)						1850 203ip	
Datenkabel USB (2m) / Data cable USB (2m)						1850 204ip	

## Digital-Taschenmessschieber, IP 67

## Digital pocket calipers, IP 67

 **TOP**
 **IP67**

 **Gehärtet Hardened**



No. 1850 151ip

Mit großer 3V Batterie.  
With large 3V battery.



- ▶ DIN 862
- ▶ Schutzart IP 67, Sylvac System
- ▶ Feststellschraube
- ▶ rostfreier Stahl, gehärtet
- ▶ großes LCD Display
- ▶ Kreuzspitzen
- ▶ Tiefenmaß eckig
- ▶ 4-fach Messung
- ▶ Lieferung im Etui

**Funktionen:**

- ▶ Ein/Aus
- ▶ Auto-On bei Bewegung
- ▶ mm/inch Umschaltung
- ▶ 0-Punkt an jeder Position
- ▶ Lock Funktion (fester 0-Punkt), absolutes System
- ▶ Datenausgang Proximity

- ▶ DIN 862
- ▶ Protection class IP 67, Sylvac System
- ▶ Locking screw
- ▶ Hardened stainless steel
- ▶ Large LCD display
- ▶ Cross points
- ▶ Depth gauge angular
- ▶ 4-way measurement
- ▶ Delivered in a case

**Functions:**

- ▶ On/Off
- ▶ Auto-On by sliding
- ▶ mm/inch commutation
- ▶ Zero setting at any position
- ▶ Lock function (fixed 0 point), absolute system
- ▶ Data output Proximity

**1850 10.ip :**  
Tiefenmaß rund Ø 1,5mm

**1850 10.ip :**  
Round depth gauge Ø 1.5mm

**1850 15.ip :**  
Tiefenmaß eckig

**1850 15.ip :**  
Angular depth gauge

mm	inch	mm	mm	inch	kg	Nº	Nº
150	6	40	0,01	.0005	0,18	1850 101ip	1850 151ip
200	8	50	0,01	.0005	0,25	1850 102ip	1850 152ip
Datenkabel RS232 (2m) / Data cable RS232 (2m)						1850 203ip	
Datenkabel USB (2m) / Data cable USB (2m)						1850 204ip	

## Digital-Taschenmessschieber, IP 67 mit langen Schnäbeln

## Digital pocket calipers, IP 67 with long jaws



No. 1850 131ip

- ▶ DIN 862
- ▶ Schutzart IP 67, Sylvac System
- ▶ Feststellschraube
- ▶ rostfreier Stahl, gehärtet
- ▶ großes LCD Display
- ▶ Kreuzspitzen
- ▶ Tiefenmaß eckig
- ▶ 4-fach Messung
- ▶ Lieferung im Etui

- ▶ DIN 862
- ▶ Protection class IP 67, Sylvac System
- ▶ Locking screw
- ▶ Hardened stainless steel
- ▶ Large LCD display
- ▶ Cross points
- ▶ Depth gauge angular
- ▶ 4-way measurement
- ▶ Delivered in a case

Mit großer 3V Batterie.  
With large 3V battery.



### Funktionen:

- ▶ Ein/Aus
- ▶ Auto-On bei Bewegung
- ▶ mm/inch Umschaltung
- ▶ 0-Punkt an jeder Position
- ▶ Lock Funktion (fester 0-Punkt), absolutes System
- ▶ Datenausgang Proximity

### Funktionen:

- ▶ On/Off
- ▶ Auto-On by sliding
- ▶ mm/inch commutation
- ▶ Zero setting at any position
- ▶ Lock function (fixed 0 point), absolute system
- ▶ Data output Proximity

### 1850 13.ip :

Mit Messflächen aus rostfreiem Stahl gehärtet

### 1850 13.ip :

Hardened stainless steel measuring faces

### 1850 14.ip :

Messflächen hartmetallbestückt

### 1850 14.ip :

Tungsten carbide-tipped measuring faces

Hartmetall  
Tungsten carbide

No. 1850 14.ip

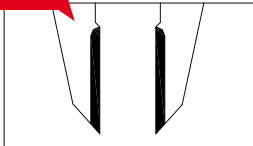

mm	inch	mm	mm	inch	kg	Nº	Nº
150	6	47	0,01	.0005	0,18	1850 131ip	1850 141ip
200	8	55	0,01	.0005	0,25	1850 132ip	1850 142ip
300	12	55	0,01	.0005	0,27	1850 133ip	1850 143ip
Datenkabel RS232 (2m) / Data cable RS232 (2m)						1850 203ip	
Datenkabel USB (2m) / Data cable USB (2m)						1850 204ip	

## Digital-Taschenmessschieber STANDARD

## Digital pocket calipers STANDARD



No. 1850 101abs

- ▶ DIN 862
- ▶ rostfreier Stahl gehärtet
- ▶ großes LCD Display
- ▶ Kreuzspitzen
- ▶ Tiefenmaß
- ▶ 4-fach Messung
- ▶ Lieferung im Etui

- ▶ DIN 862
- ▶ Hardened stainless steel
- ▶ Large LCD display
- ▶ Cross points
- ▶ Depth gauge
- ▶ 4-way measurement
- ▶ Delivered in a case

### Funktionen:

- ▶ Ein/Aus
- ▶ mm/inch Umschaltung
- ▶ 0-Punkt an jeder Position
- ▶ Auto OFF ( nicht ABS Modelle )
- ▶ ABS/INC Funktion

### Funktionen:

- ▶ On/Off
- ▶ mm/inch commutation
- ▶ Zero setting at any position
- ▶ Auto OFF (not ABS model)
- ▶ ABS/INC function

### 1850 101abs :

Tiefenmaß eckig

### 1850 101abs :

Angular depth gauge

### 1850 101rt :

Tiefenmaß rund ø1,5mm

### 1850 101rt :

Round depth gauge ø1.5mm

### 1850 101hm :

Messflächen hartmetallbestückt, Tiefenmaß eckig

### 1850 101hm :

Tungsten carbide-tipped meas. faces, Angular depth gauge

Hartmetall  
Tungsten carbide

No. 1850 101hm

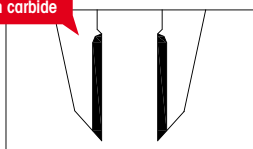

mm	inch	mm	mm	inch	kg	Nº
150	6	40	0,01	.0005	0,4	1850 101abs
150	6	40	0,01	.0005	0,4	1850 101rt
150	6	40	0,01	.0005	0,4	1850 101hm



**Digital-Taschenmessschieber STANDARD**

**Digital pocket calipers STANDARD**

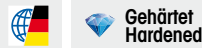

No. 1850 101s

Mit großer 3V Batterie.  
With large 3V battery.



Extra große Ziffern 11mm  
Extra large digits 11mm

No. 1850 401s

Mit großer 3V Batterie.  
With large 3V battery.



- ▶ DIN 862
- ▶ Feststellschraube
- ▶ rostfreier Stahl gehärtet
- ▶ großes LCD Display
- ▶ Verfahrgeschwindigkeit 3m/s
- ▶ Kreuzspitzen
- ▶ Tiefenmaß eckig
- ▶ 4-fach Messung
- ▶ Lieferung im Etui

- Funktionen:**
- ▶ Ein/Aus
  - ▶ mm/inch Umschaltung
  - ▶ O-Punkt an jeder Position

- ▶ DIN 862
- ▶ Locking screw
- ▶ Hardened stainless steel
- ▶ Large LCD display
- ▶ Measuring speed 3m/s
- ▶ Cross points
- ▶ Depth gauge angular
- ▶ 4-way measurement
- ▶ Delivered in a case

- Funktionen:**
- ▶ On/Off
  - ▶ mm/inch commutation
  - ▶ Zero setting at any position

**1850 1..s :**  
STANDARD-Ausführung LCD-Ziffern 7,5mm

**1850 1..s :**  
STANDARD model LCD-digits 7.5mm

**1850 401s :**  
Extra große LCD-Ziffern 11mm, ABS/INC Funktion

**1850 401s :**  
Extra large LCD-digits 11mm, ABS/INC function

mm	inch	mm	mm	inch	kg	Nº
150	6	40	0,01	.0005	0,4	1850 101s
200	8	50	0,01	.0005	0,5	1850 102s
300	12	60	0,01	.0005	0,6	1850 103s
150	6	40	0,01	.0005	0,4	1850 401s

**Digital-Tiefenmessschieber STANDARD**

**Digital depth calipers STANDARD**



No. 1852 099s

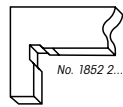
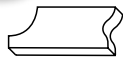

No. 1852 2...

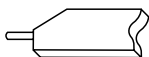

No. 1852 4...

- ▶ DIN 862
- ▶ Feststellschraube
- ▶ rostfreier Stahl gehärtet
- ▶ großes LCD Display
- ▶ Lieferung im Etui

- Funktionen:**
- ▶ Ein/Aus
  - ▶ mm/inch Umschaltung
  - ▶ O-Punkt an jeder Position

- ▶ DIN 862
- ▶ Locking screw
- ▶ Hardened stainless steel
- ▶ Large LCD display
- ▶ Delivered in a case

- Functions:**
- ▶ On/Off
  - ▶ mm/inch commutation
  - ▶ Zero setting at any position

mm	inch	mm	mm	inch	kg	Nº
abgeschrägte Spitze / Bevelled point						
150	6	100	0,01	.0005	0,4	1852 098s
200	8	100	0,01	.0005	0,5	1852 099s
300	12	150	0,01	.0005	0,6	1852 101s
500	20	150	0,01	.0005	0,7	1852 102s
Winkelhaken / Hook						
300	12	150	0,01	.0005	0,6	1852 201s
500	20	150	0,01	.0005	0,7	1852 202s
Stahlstift gehärtet / Steel pin hardened						
150	6	100	0,01	.0005	0,4	1852 398s
200	8	100	0,01	.0005	0,5	1852 399s
300	12	150	0,01	.0005	0,6	1852 401s

Lieferprogramm Tiefenmessschieber ab Seite 11.33 / Product range depth calipers starting from page 11.33

**Digital-Taschenmessschieber  
STANDARD Linkshänder Modell**

**Digital pocket calipers  
STANDARD Left-hand model**



**Gehärtet  
Hardened**



No. 1850 401slh

- ▶ DIN 862
- ▶ rostfreier Stahl gehärtet
- ▶ großes LCD Display, Ziffernhöhe 11mm
- ▶ Kreuzspitzen
- ▶ Tiefenmaß eckig
- ▶ 4-fach Messung
- ▶ Lieferung im Etui

**Funktionen:**

- ▶ Ein/Aus
- ▶ mm/inch Umschaltung
- ▶ 0-Punkt an jeder Position
- ▶ Auto OFF

- ▶ DIN 862
- ▶ Hardened stainless steel
- ▶ Large LCD display, 11mm high digits
- ▶ Cross points
- ▶ Depth gauge angular
- ▶ 4-way measurement
- ▶ Delivered in a case

**Functions:**

- ▶ On/Off
- ▶ mm/inch commutation
- ▶ Zero setting at any position
- ▶ Auto OFF

mm	inch	mm	mm	inch	kg	Nº
150	6	40	0,01	.0005	0,4	1850 401slh

**Messeinsätze  
für Taschenmessschieber, Satz**

**Measuring inserts  
for pocket calipers, set**



No. 1850 901

**Inhalt:**

- ▶ Messeinsätze mit Scheiben Ø 6 / 10 / 12,5mm, Paar
- ▶ Messeinsätze mit 60° Konus, Ø 9 / 12,5mm, Paar
- ▶ Messeinsätze mit zylindrischen Messflächen 1,5mm, Paar
- ▶ Messeinsatzträger rechts / links
- ▶ Sechskantschlüssel
- ▶ Lieferung im Etui

**Contents:**

- ▶ Measuring inserts with discs Ø 6 / 10 / 12.5mm, pair
- ▶ Measuring inserts with 60° cone Ø 9 / 12.5mm, pair
- ▶ Measuring inserts with cylindric measuring faces 1.5mm, pair
- ▶ Insert holder right / left
- ▶ Allen wrench
- ▶ Delivered in a case

Stück Pieces	kg	Nº
5	0,4	1850 901



No. 1850 201

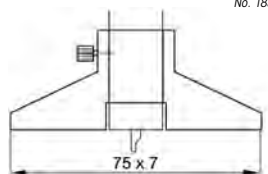

**Tiefenmessbrücken  
für Taschenmessschieber**

**Depth measuring bridges  
for pocket calipers**



**Gehärtet  
Hardened**

- ▶ rostfreier Stahl gehärtet
- ▶ Stangenbreite max. 16mm
- ▶ Lieferung einzeln verpackt

- ▶ Hardened stainless steel
- ▶ Rod width max. 16mm
- ▶ Delivered in individual packages

mm	kg	Nº
75	0,05	1850 201

## Digital-Taschenmessschieber IP 67 für Außennuten und Einstiche

## Digital pocket calipers IP 67 for grooves and recesses



No. 1850 601

Mit großer 3V Batterie.  
With large 3V battery.

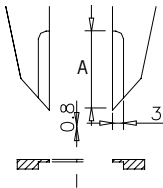

- ▶ DIN 862
- ▶ Schutzart IP 67, Sylvac System
- ▶ Feststellschraube
- ▶ rostfreier Stahl gehärtet
- ▶ großes LCD Display
- ▶ Kreuzspitzen
- ▶ Tiefenmaß eckig
- ▶ 4-fach Messung
- ▶ Lieferung im Etui

### Funktionen:

- ▶ Ein/Aus
- ▶ Auto-On bei Bewegung
- ▶ mm/inch Umschaltung
- ▶ 0-Punkt an jeder Position
- ▶ ABS Funktion ( fester 0-Punkt )
- ▶ Datenausgang Proximity

- ▶ DIN 862
- ▶ Protection class IP 67, Sylvac System
- ▶ Locking screw
- ▶ Hardened stainless steel
- ▶ Large LCD display
- ▶ Cross points
- ▶ Depth gauge angular
- ▶ 4-way measurement
- ▶ Delivered in a case

### Functions:

- ▶ On/Off
- ▶ Auto-On by sliding
- ▶ mm/inch commutation
- ▶ Zero setting at any position
- ▶ ABS function (fixed 0 point)
- ▶ Data output Proximity

mm	inch	A mm	W mm	mm	inch	kg	Nº
150	6	25	47	0,01	.0005	0,19	1850 601
200	8	30	55	0,01	.0005	0,23	1850 602
250	10	30	55	0,01	.0005	0,25	1850 603

Datenkabel RS232 (2m) / Data cable RS232 (2m)

1850 203ip

Datenkabel USB (2m) / Data cable USB (2m)

1850 204ip

## Digital-Taschenmessschieber IP 67 für dünne Bohrungen

## Digital pocket calipers IP 67 for small holes



No. 1850 611

Mit großer 3V Batterie.  
With large 3V battery.

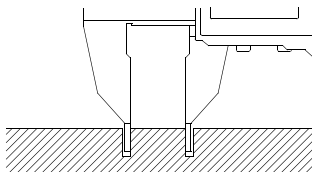
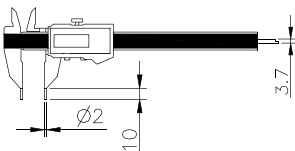

- ▶ Werksnorm
- ▶ Schutzart IP 67, Sylvac System
- ▶ Feststellschraube
- ▶ rostfreier Stahl gehärtet
- ▶ großes LCD Display
- ▶ Kreuzspitzen
- ▶ Tiefenmaß eckig
- ▶ Lieferung im Etui

### Funktionen:

- ▶ Ein/Aus
- ▶ Auto-On bei Bewegung
- ▶ mm/inch Umschaltung
- ▶ 0-Punkt an jeder Position
- ▶ ABS Funktion ( fester 0-Punkt )
- ▶ Datenausgang Proximity

- ▶ Works standard
- ▶ Protection class IP 67, Sylvac System
- ▶ Locking screw
- ▶ Hardened stainless steel
- ▶ Large LCD display
- ▶ Cross points
- ▶ Depth gauge angular
- ▶ Delivered in a case

### Functions:

- ▶ On/Off
- ▶ Auto-On by sliding
- ▶ mm/inch commutation
- ▶ Zero setting at any position
- ▶ ABS function (fixed 0 point)
- ▶ Data output Proximity

mm	inch	W mm	mm	inch	kg	Nº
150	6	47	0,01	.0005	0,18	1850 611

Datenkabel RS232 (2m) / Data cable RS232 (2m)

1850 203ip

Datenkabel USB (2m) / Data cable USB (2m)

1850 204ip

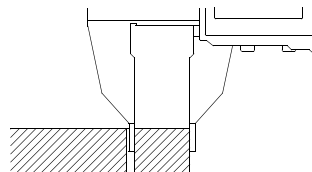

**Digital-Taschenmessschieber IP 67  
für Wandstärke und ungleiche Werkstücke**

**Digital pocket calipers IP 67  
for wall thickness and irregular workpieces**

 **NEW**
 **IP67**

 **Gehärtet  
Hardened**



No. 1850 621

- ▶ Werksnorm
- ▶ Schutzart IP 67, Sylvac System
- ▶ Feststellschraube
- ▶ rostfreier Stahl gehärtet
- ▶ großes LCD Display
- ▶ Kreuzspitzen
- ▶ Tiefenmaß eckig
- ▶ Lieferung im Etui

- ▶ Works standard
- ▶ Protection class IP 67, Sylvac System
- ▶ Locking screw
- ▶ Hardened stainless steel
- ▶ Large LCD display
- ▶ Cross points
- ▶ Depth gauge angular
- ▶ Delivered in a case

Mit großer 3V Batterie.  
With large 3V battery.



**Funktionen:**

- ▶ Ein/Aus
- ▶ Auto-On bei Bewegung
- ▶ mm/inch Umschaltung
- ▶ 0-Punkt an jeder Position
- ▶ ABS Funktion ( fester 0-Punkt )
- ▶ Datenausgang Proximity

**Functions:**

- ▶ On/Off
- ▶ Auto-On by sliding
- ▶ mm/inch commutation
- ▶ Zero setting at any position
- ▶ ABS function (fixed 0 point)
- ▶ Data output Proximity

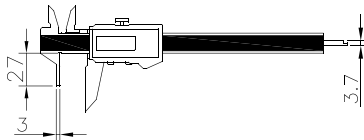

mm	inch	mm	mm	inch	kg	Nº
150	6	47	0,01	.0005	0,17	1850 621
Datenkabel RS232 (2m) / Data cable RS232 (2m)						1850 203ip
Datenkabel USB (2m) / Data cable USB (2m)						1850 204ip

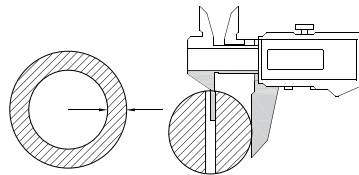

**Digital-Taschenmessschieber IP 67  
mit extra langen Kreuzspitzen**

**Digital pocket calipers IP 67  
with extra long crosspoints**

 **NEW**
 **IP67**

 **Gehärtet  
Hardened**



No. 1850 631

- ▶ Werksnorm
- ▶ Schutzart IP 67, Sylvac System
- ▶ Feststellschraube
- ▶ rostfreier Stahl gehärtet
- ▶ großes LCD Display
- ▶ Kreuzspitzen
- ▶ Tiefenmaß eckig
- ▶ Lieferung im Etui

- ▶ Works standard
- ▶ Protection class IP 67, Sylvac System
- ▶ Locking screw
- ▶ Hardened stainless steel
- ▶ Large LCD display
- ▶ Cross points
- ▶ Depth gauge angular
- ▶ Delivered in a case

Mit großer 3V Batterie.  
With large 3V battery.



**Funktionen:**

- ▶ Ein/Aus
- ▶ Auto-On bei Bewegung
- ▶ mm/inch Umschaltung
- ▶ 0-Punkt an jeder Position
- ▶ ABS Funktion ( fester 0-Punkt )
- ▶ Datenausgang Proximity

**Functions:**

- ▶ On/Off
- ▶ Auto-On by sliding
- ▶ mm/inch commutation
- ▶ Zero setting at any position
- ▶ ABS function (fixed 0 point)
- ▶ Data output Proximity

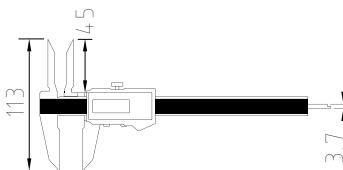

mm	inch	mm	mm	inch	kg	Nº
150	6	47	0,01	.0005	0,2	1850 631
Datenkabel RS232 (2m) / Data cable RS232 (2m)						1850 203ip
Datenkabel USB (2m) / Data cable USB (2m)						1850 204ip

**Digital-Messschieber, Nutsymmetriemessgerät für Nutmittenabstandsmessung**

**Digital calipers for slot center distance measuring**

No. 1850 651



★ **NEW**



- ▶ Werksnorm
- ▶ für Wellendurchmesser ≤120mm
- ▶ Feststellschraube
- ▶ rostfreier Stahl gehärtet
- ▶ großes LCD-Display
- ▶ 2 bewegliche Tastarme
- ▶ Lieferung im Etui

- Funktionen:**
- ▶ Ein/Aus
  - ▶ mm/inch Umschaltung
  - ▶ 0-Punkt an jeder Position
  - ▶ ABS Funktion (fester 0-Punkt)

- ▶ Works standard
- ▶ for shaft diameter ≤120mm
- ▶ Locking screw
- ▶ Hardened stainless steel
- ▶ Large LCD display
- ▶ 2 moveable arms
- ▶ Delivered in individual packages

- Funktionen:**
- ▶ On/Off
  - ▶ mm/inch commutation
  - ▶ Zero setting at any position
  - ▶ ABS function (fixed 0 point)

◀< links/left		◀< rechts/right		◀< mm	kg	Nº
mm	inch	mm	inch			
0 - 40	0 - 1,6	0 - 70	0 - 2.8	0,01	0,5	1850 651

**Digital Schnellfaster für Nutmittenabstandsmessung**

**Digital dial caliper gauges for slot center distance measuring**

No. 1347 301



★ **NEW**

**sylvac**  
System



- ▶ Werksnorm
- ▶ Schutzart IP 54, Sylvac System
- ▶ großes LCD-Display
- ▶ 1 fester Tastarm für auswechselbare Nutsteine, 1 beweglicher Tastarm
- ▶ Lieferung im Etui ohne Nutstein

- Funktionen:**
- ▶ Ein/Aus
  - ▶ mm/inch Umschaltung
  - ▶ 0-Punkt an jeder Position
  - ▶ ± Preset Funktion
  - ▶ Datenausgang Opto

- ▶ Works standard
- ▶ Protection class IP 54, Sylvac system
- ▶ Large LCD display
- ▶ 1 fixed arm for interchangeable sliding blocks and 1 movable arm
- ▶ Delivered in case without sliding blocks

- Funktionen:**
- ▶ On/Off
  - ▶ mm/inch commutation
  - ▶ Zero setting at any position
  - ▶ ± Preset function
  - ▶ Data output Opto

1 Bei Bestellung von Nr. 1347 351 Nutbreite (4-20mm) angeben

1 Specify slot width (4-20mm) in case of order no. 1347 351

mm	◀< mm	mm	N	A mm	B mm	kg	Nº
8 - 58	0,01	0,02	5	29	4	0,4	1347 301
50 - 100	0,01	0,02	5	50	25	0,4	1347 302

1 Stück Nutstein 4-20mm / 1 pcs. Key slot 4-20mm

Datenkabel RS232 (2m) / Data cable RS232 (2m)

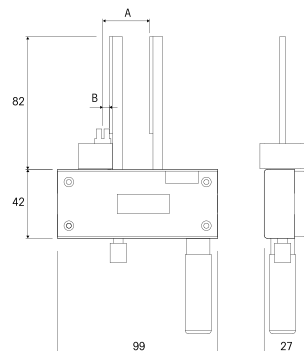

Datenkabel USB (2m) / Data cable USB (2m)

1347 351  
1850 203  
1850 204



**Taschenmessschieber Präzisionsausführung mit Momentfeststellung**

**Pocket vernier calipers Precision model with thumb lock**



- ▶ DIN 862
- ▶ rostfreier Stahl gehärtet
- ▶ Ableseteile mattverchromt
- ▶ Kreuzspitzen
- ▶ Tiefenmaß
- ▶ 4-fach Messung
- ▶ Lieferung in Kunstledertasche

- ▶ DIN 862
- ▶ Hardened stainless steel
- ▶ Satin chrome reading parts
- ▶ Cross points
- ▶ Depth gauge
- ▶ 4-way measurement
- ▶ Delivered in imitation leather bag

**1866 10. :**  
Tiefenmaß eckig

**1866 10. :**  
Angular depth gauge

**1866 101rt :**  
Tiefenmaß rund

**1866 101rt :**  
Round depth gauge

! Ablesung 1/50mm auf Anfrage.

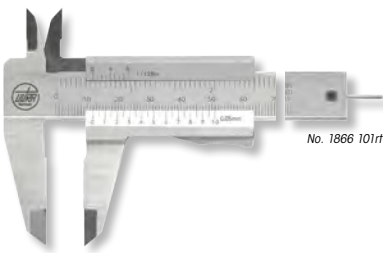

! Reading 1/50mm on request.

mm	inch	mm	mm	inch	kg	Nº
150	6	40	1/20	1/128	0,15	1866 101
200	8	50	1/20	1/128	0,2	1866 102
150	6	40	1/20	1/128	0,15	1866 101rt



**Taschenmessschieber Präzisionsausführung mit Feststellschraube**

**Pocket vernier calipers Precision model with locking screw**



- ▶ DIN 862
- ▶ rostfreier Stahl gehärtet
- ▶ Ableseteile mattverchromt
- ▶ Kreuzspitzen
- ▶ Tiefenmaß eckig
- ▶ 4-fach Messung
- ▶ Lieferung in Kunstledertasche

- ▶ DIN 862
- ▶ Hardened stainless steel
- ▶ Satin chrome reading parts
- ▶ Cross points
- ▶ Angular depth gauge
- ▶ 4-way measurement
- ▶ Delivered in imitation leather bag

mm	inch	mm	mm	inch	kg	Nº
150	6	40	1/20	1/128	0,15	1868 101
200	8	50	1/20	1/128	0,2	1868 102
300	12	60	1/20	1/128	0,25	1868 103

**Kleinformmessschieber**

**Small vernier calipers**



- ▶ Werksnorm
- ▶ Feststellschraube
- ▶ rostfreier Stahl gehärtet
- ▶ Ableseteile mattverchromt
- ▶ Kreuzspitzen, Tiefenmaß eckig
- ▶ Lieferung in Kunstledertasche

- ▶ Works standard
- ▶ Locking screw
- ▶ Hardened stainless steel
- ▶ Satin chrome reading parts
- ▶ Cross points, depth gauge angular
- ▶ Delivered in imitation leather bag

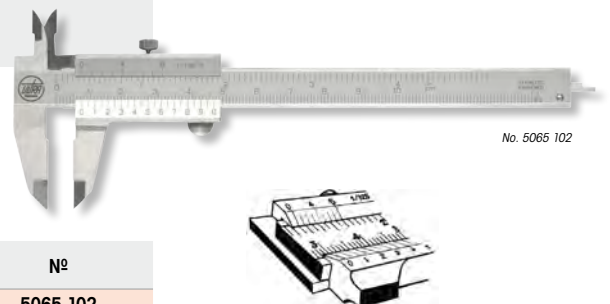

mm	mm	mm	kg	Nº
100	25	1/20	0,12	5065 102
100	27	1/50	0,12	5065 202

**Taschenmessschieber, parallaxfreie Ablesung mit Momentfeststellung**

**Pocket vernier calipers, parallax free reading with thumb lock**



**Gehärtet  
Hardened**

Parallaxfreie Ablesung  
Parallax free reading



No. 1866 201

- ▶ DIN 862
- ▶ rostfreier Stahl gehärtet
- ▶ Ablese- und Messbereiche, Teilung und Nonius auf einer Ebene
- ▶ Kreuzspitzen
- ▶ Tiefenmaß eckig
- ▶ 4-fach Messung
- ▶ Lieferung im Etui

- ▶ DIN 862
- ▶ Hardened stainless steel
- ▶ Satin-chrome reading parts, scale and vernier on one level
- ▶ Cross points
- ▶ Depth gauge angular
- ▶ 4-way measurement
- ▶ Delivered in a case

mm	inch	WF mm	mm	inch	kg	Nº
150	6	40	1/20	1/128	0,18	1866 201
150	6	40	1/50	1/1000	0,18	1866 202

**Taschenmessschieber, parallaxfreie Ablesung mit Feststellschraube**

**Pocket vernier calipers, parallax free reading with locking screw**



**Gehärtet  
Hardened**

Parallaxfreie Ablesung  
Parallax free reading



No. 1868 201

- ▶ DIN 862
- ▶ rostfreier Stahl gehärtet
- ▶ Ablese- und Messbereiche, Teilung und Nonius auf einer Ebene
- ▶ Kreuzspitzen
- ▶ Tiefenmaß eckig
- ▶ 4-fach Messung
- ▶ Lieferung im Etui

- ▶ DIN 862
- ▶ Hardened stainless steel
- ▶ Satin-chrome reading parts, scale and vernier on one level
- ▶ Cross points
- ▶ Depth gauge angular
- ▶ 4-way measurement
- ▶ Delivered in a case

mm	inch	WF mm	mm	inch	kg	Nº
150	6	40	1/20	1/128	0,18	1868 201
150	6	40	1/50	1/1000	0,18	1868 202

**Taschenmessschieber, parallaxfreie Ablesung mit Doppel-Prismenführung, Feststellschraube**

**Pocket vernier calipers, parallax free reading with double V guide, with locking screw**



**Gehärtet  
Hardened**

Parallaxfreie Ablesung  
Parallax free reading



No. 1868 201dp

- ▶ DIN 862
- ▶ rostfreier Stahl gehärtet
- ▶ Ablese- und Messbereiche, Teilung und Nonius auf einer Ebene
- ▶ Kreuzspitzen
- ▶ Tiefenmaß eckig
- ▶ 4-fach Messung
- ▶ Lieferung im Etui

- ▶ DIN 862
- ▶ Hardened stainless steel
- ▶ Satin-chrome reading parts, scale and vernier on one level
- ▶ Cross points
- ▶ Depth gauge angular
- ▶ 4-way measurement
- ▶ Delivered in a case



Doppel-Prismenführung  
Double V guide

mm	inch	WF mm	mm	inch	kg	Nº
150	6	40	1/20	1/128	0,18	1868 201dp
150	6	40	1/50	1/1000	0,18	1868 202dp

**Taschenmessschieber STANDARD**

**Pocket vernier calipers, STANDARD**



No. 1866 101s

- ▶ DIN 862
- ▶ für Schulen und Werkstatt
- ▶ Momentverstellung oder Feststellschraube
- ▶ rostfreier Stahl gehärtet
- ▶ Ableseteile mattverchromt
- ▶ Kreuzspitzen
- ▶ Tiefenmaß
- ▶ 4-fach Messung
- ▶ Lieferung in Kunstledertasche

- ▶ DIN 862
- ▶ For schools and workshops
- ▶ Thumb lock or locking screw
- ▶ Hardened stainless steel
- ▶ Satin chrome reading parts
- ▶ Cross points
- ▶ Depth gauge
- ▶ 4-way measurement
- ▶ Delivered in imitation leather bag

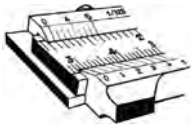

No. 1868 101s

**1866 ...s / 1868 ...s :**  
Tiefenmaß eckig

**1866 ...s / 1868 ...s :**  
Angular depth gauge

**1868 101rt :**  
Tiefenmaß rund

**1868 101rt :**  
Round depth gauge

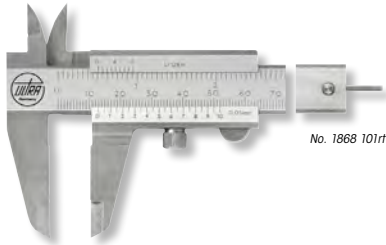

No. 1868 101rt

mm	inch	mm	mm	inch	kg	Nº
Momentverstellung / Thumb lock						
150	-	40	1/20	-	0,15	<b>1866 100s</b>
150	6	40	1/20	1/128	0,15	<b>1866 101s</b>
150	6	40	1/50	1/1000	0,15	<b>1866 501s</b>
Feststellschraube / Locking screw						
150	-	40	1/20	-	0,15	<b>1868 100s</b>
150	6	40	1/20	1/128	0,15	<b>1868 101s</b>
150	6	40	1/20	1/128	0,15	<b>1868 101rt</b>
150	6	40	1/50	1/1000	0,15	<b>1868 501s</b>

**Taschenmessschieber STANDARD  
Linkshänder-Modell**

**Pocket vernier calipers, STANDARD  
Left-hand model**



- ▶ DIN 862
- ▶ für Schulen und Werkstatt
- ▶ Momentverstellung oder Feststellschraube
- ▶ rostfreier Stahl gehärtet
- ▶ Ableseteile mattverchromt
- ▶ Kreuzspitzen
- ▶ Tiefenmaß eckig
- ▶ 4-fach Messung
- ▶ Lieferung in Kunstledertasche

- ▶ DIN 862
- ▶ For schools and workshops
- ▶ Thumb lock or locking screw
- ▶ Hardened stainless steel
- ▶ Satin chrome reading parts
- ▶ Cross points
- ▶ Depth gauge angular
- ▶ 4-way measurement
- ▶ Delivered in imitation leather bag



No. 1866 101sh

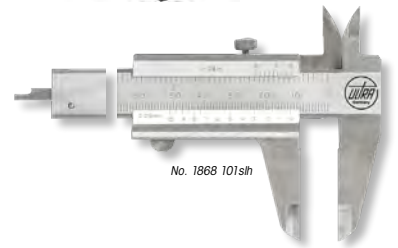
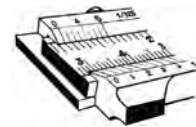

No. 1868 101sh

mm	inch	mm	mm	inch	kg	Nº
Momentverstellung / Thumb lock						
150	6	40	1/20	1/128	0,15	<b>1866 101sh</b>
150	6	40	1/50	1/1000	0,15	<b>1866 501sh</b>
Feststellschraube / Locking screw						
150	6	40	1/20	1/128	0,15	<b>1868 101sh</b>
150	6	40	1/50	1/1000	0,15	<b>1868 501sh</b>



**Taschenmessschieber mit Uhrablesung**

**Pocket dial calipers**



No. 5061 202



**Gehärtet  
Hardened**

- ▶ DIN 862
- ▶ Feststellschraube
- ▶ rostfreier Stahl gehärtet
- ▶ Ableseteile mattverchromt
- ▶ Kreuzspitzen, Tiefenmaß
- ▶ 4-fach Messung
- ▶ Lieferung im Etui

- ▶ DIN 862
- ▶ Locking screw
- ▶ Hardened stainless steel
- ▶ Satin chrome reading parts
- ▶ Cross points, depth gauge
- ▶ 4-way measurement
- ▶ Delivered in a case

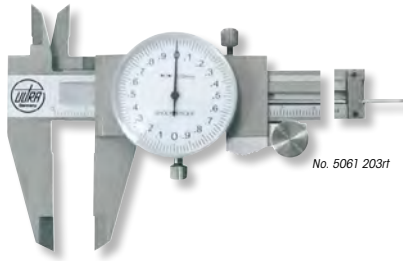

No. 5061 203rt

**5061 2.. :**  
Tiefenmaß eckig

**5061 2.. :**  
Angular depth gauge

**5061 203rt :**  
Tiefenmaß rund Ø 1,6mm

**5061 203rt :**  
Round depth gauge Ø 1.6mm

∏ mm	∏ mm	≤ mm	∅ mm	kg	Nº
150	40	0,05	5	0,15	<b>5061 202</b>
200	50	0,05	5	0,18	<b>5061 212</b>
150	40	0,02	2	0,15	<b>5061 203</b>
200	50	0,02	2	0,18	<b>5061 213</b>
300	60	0,02	2	0,4	<b>5061 216</b>
150	40	0,01	1	0,15	<b>5061 204</b>
200	50	0,01	1	0,18	<b>5061 214</b>
150	40	0,02	2	0,15	<b>5061 203rt</b>

**Messzeugsätze**

**Measuring tool sets**



No. 5026 102



**★ NEW**

- ▶ Lieferung im Kunststoffkoffer

- ▶ Delivered in box

**Inhalt Nr. 5026 102:**  
Taschenmessschieber 150mm  
Bügelmessschraube 0 – 25mm  
Haarwinkel 100 x 70mm

**Content of No. 5026 102:**  
Pocket calipers 150mm  
Micrometer 0 – 25mm  
Bevel edge square 100 x 70mm



No. 5026 103

**Inhalt Nr. 5026 103:**  
Taschenmessschieber 150mm  
Bügelmessschraube 0 – 25mm  
biegsamer Stahlmaßstab 200mm, rostfrei  
Haarwinkel 100 x 70mm, Haarlineal 100mm  
Federspitzzirkel 100mm, Reißnadel 150mm

**Content of No. 5026 103:**  
Pocket calipers 150mm  
Micrometer 0 – 25mm  
Flexible stainless steel rule 200mm  
Bevel edge square 100 x 70mm, Knife straightedge 100mm  
Spring dividers 100mm, Scriber 175mm

- ! Andere Satzzusammenstellungen auf Anfrage.

- ! Other set compositions on request.

Stück Pieces	kg	Nº
3	1,0	<b>5026 102</b>
7	1,3	<b>5026 103</b>

**Messschieber für Keilnutentiefe**

**Vernier calipers for keyway depth**

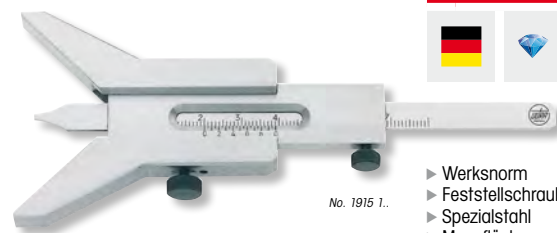

No. 1915 1..



**Gehärtet  
Hardened**

- ▶ Werksnorm
- ▶ Feststellschraube
- ▶ Spezialstahl
- ▶ Messflächen gehärtet
- ▶ Lieferung einzeln verpackt

- ▶ Works standard
- ▶ Locking screw
- ▶ Special steel
- ▶ Hardened measuring faces
- ▶ Delivered in individual packages

∏ mm	Wellen / Shaft ∅-mm	≤ mm	kg	Nº
120	6 – 120	1/20	0,22	<b>1915 102</b>

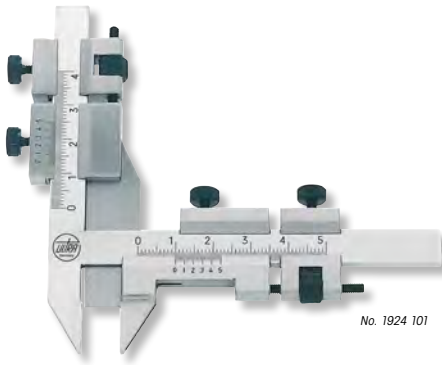

No. 1924 101

**Messschieber für Zahnweite und Zahndicke**

**Vernier calipers for tooth width and thickness**



- ▶ Werksnorm
- ▶ Feststellschraube und Feineinstellung
- ▶ rostfreier Stahl gehärtet
- ▶ Ablese Teile mattverchromt
- ▶ Lieferung im Etui

- ▶ Works standard
- ▶ Locking screw and fine adjustment
- ▶ Stainless steel hardened
- ▶ Satin chrome reading parts
- ▶ Delivered in a case

**1924 101 :**  
Messflächen gehärtet

**1924 101 :**  
Hardened measuring faces

**1925 101 :**  
Messflächen hartmetallbestückt

**1925 101 :**  
Tungsten carbide-tipped measuring faces

Modul Module	$\leq$ mm	$\bar{m}$ kg	Nº	Nº
1 – 26	1/50	0,15	1924 101	1925 101

**Digital-Messschieber für 3 oder 5 schneidige Werkzeuge**

**Digital calipers for 3 or 5 edged tools**



**Gehärtet  
Hardened**



No. 5078 301

- ▶ Werksnorm
- ▶ Feststellschraube
- ▶ rostfreier Stahl gehärtet
- ▶ großes LCD Display
- ▶ Lieferung im Etui

- ▶ Works standard
- ▶ Locking screw
- ▶ Hardened stainless steel
- ▶ Large LCD display
- ▶ Delivered in a case

**Funktionen:**  
▶ Ein/Aus  
▶ mm/inch Umschaltung  
▶ 0-Punkt an jeder Position

**Functions:**  
▶ On/Off  
▶ mm/inch commutation  
▶ Zero setting at any position

**5078 301 :**  
3-Punkt-Messung

**5078 301 :**  
3-point measuring

**5078 401 :**  
5-Punkt-Messung

**5078 401 :**  
5-point measuring

mm	$\frac{1}{100}$	inch	mm	$\leq$	inch	$\bar{m}$ kg	Nº
4 – 40		.15 – 1.5	0,01		.0005	0,11	5078 301
2 – 40		.08 – 1.5	0,01		.0005	0,1	5078 401

3-Punkt-Messung  
3-point measuring

5-Punkt-Messung  
5-point measuring



**Messschieber für 3 oder 5 schneidige Werkzeuge**

**Vernier calipers for 3 or 5 edged tools**



**Gehärtet  
Hardened**

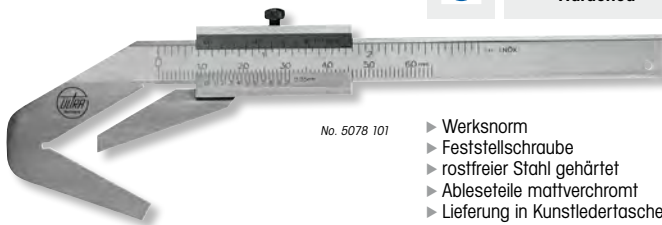

No. 5078 101

- ▶ Werksnorm
- ▶ Feststellschraube
- ▶ rostfreier Stahl gehärtet
- ▶ Ablese Teile mattverchromt
- ▶ Lieferung in Kunstledertasche

- ▶ Works standard
- ▶ Locking screw
- ▶ Hardened stainless steel
- ▶ Satin chrome reading parts
- ▶ Delivered in imitation leather bag

**5078 101 :**  
3-Punkt-Messung

**5078 101 :**  
3-point measuring

**5078 201 :**  
5-Punkt-Messung

**5078 201 :**  
5-point measuring

mm	$\frac{1}{100}$	inch	mm	$\leq$	inch	$\bar{m}$ kg	Nº
4 – 40		.15 – 1,5	1/20		1/128	0,11	5078 101
2 – 40		.08 – 1,5	1/20		1/128	0,1	5078 201

3-Punkt-Messung  
3-point measuring

5-Punkt-Messung  
5-point measuring



**Messschieber für Bremscheiben**

**Vernier calipers for brake discs**

**Gehärtet Hardened**



No. 5088 101

- ▶ Werksnorm
- ▶ Feststellschraube
- ▶ mit Schleppschieber
- ▶ rostfreier Stahl gehärtet
- ▶ Ableseteile mattverchromt
- ▶ Lieferung einzeln verpackt

- ▶ Works standard
- ▶ Locking screw
- ▶ With trailing slide
- ▶ Hardened stainless steel
- ▶ Satin chrome reading parts
- ▶ Delivered in individual packages

**5088 101 :**  
für PkV

**5088 101 :**  
For cars

**5088 102 :**  
für LkV

**5088 102 :**  
For lorries

mm	mm	$\leq$ mm	kg	Nº
50	75	1/10	0,1	<b>5088 101</b>
100	120	1/10	0,2	<b>5088 102</b>

**Messschieber für Bremsstromeln**

**Vernier calipers for brake drums**

**Gehärtet Hardened**

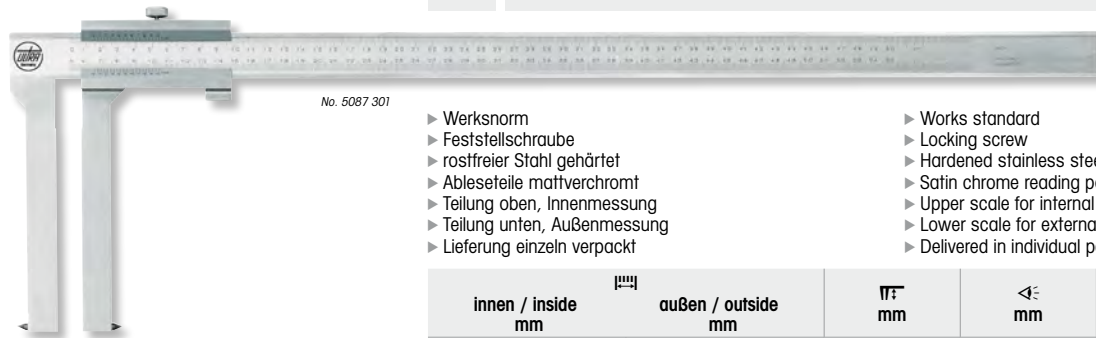

No. 5087 301

- ▶ Werksnorm
- ▶ Feststellschraube
- ▶ rostfreier Stahl gehärtet
- ▶ Ableseteile mattverchromt
- ▶ Teilung oben, Innenmessung
- ▶ Teilung unten, Außenmessung
- ▶ Lieferung einzeln verpackt

- ▶ Works standard
- ▶ Locking screw
- ▶ Hardened stainless steel
- ▶ Satin chrome reading parts
- ▶ Upper scale for internal measurement
- ▶ Lower scale for external measurement
- ▶ Delivered in individual packages

innen / inside mm	außen / outside mm	mm	$\leq$ mm	kg	Nº
50 – 500	0 – 500	150	1/20	1,2	<b>5087 301</b>

**Messschieber für Innennuten**

**Vernier calipers for inside grooves**

**Gehärtet Hardened**

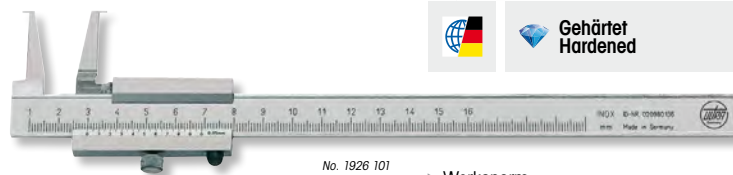

No. 1926 101

- ▶ Werksnorm
- ▶ Feststellschraube
- ▶ rostfreier Stahl gehärtet
- ▶ Ableseteile mattverchromt
- ▶ Lieferung einzeln verpackt

- ▶ Works standard
- ▶ Locking screw
- ▶ Hardened stainless steel
- ▶ Satin chrome reading parts
- ▶ Delivered in individuell packages

**1926 1.. :**  
Messschieber

**1926 1.. :**  
Vernier calipers

**1927 1.. :**  
Holzetui

**1927 1.. :**  
Wooden box

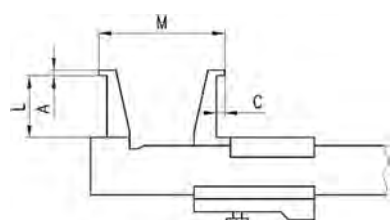

mm	L mm	A mm	C mm	$\leq$ mm	kg	Nº	Nº
10 – 160	25	0,9	3,0	1/20	0,15	<b>1926 101</b>	<b>1927 101</b>
20 – 160	40	2,0	5,0	1/20	0,2	<b>1926 102</b>	<b>1927 102</b>
26 – 200	60	3,0	7,0	1/20	0,3	<b>1926 103</b>	<b>1927 103</b>
30 – 250	80	4,0	8,5	1/20	0,35	<b>1926 104</b>	<b>1927 104</b>
35 – 300	100	5,0	10,0	1/20	0,5	<b>1926 105</b>	<b>1927 105</b>

## Digital-Universalmessschieber CARBON für Innen- und Außenmessung

## Digital universal measuring instrument CARBON for inside and outside measurement



Lange Messschnäbel  
Long measuring jaws



No. 1854 2.

Konstante Messkraft  
Constant measuring force

Stangenquerschnitt  
Bar cross section  
30x10mm

- ▶ Werksnorm
- ▶ Schutzart IP 54, Sylvac System
- ▶ Feststellschraube
- ▶ Mit konstanter Messkraft durch Feder
- ▶ großes LCD Display
- ▶ Messeinsätze auswechselbar
- ▶ Stange aus Kohlefaser 30x10mm, Führungselemente aus verchromten Stahl
- ▶ Extrem geringes Gewicht, hohe Formstabilität
- ▶ Lieferung im Holzetui inkl. je 1 Paar Hülsen Ø 3,5mm mit Innengewinde M 2,5 und Standard-Messeinsätzen Kugel Ø 3mm

- ▶ Works standard
- ▶ Protection class IP 54, Sylvac System
- ▶ Locking screw
- ▶ With constant measuring force due spring
- ▶ Large LCD display
- ▶ Interchangeable measuring inserts
- ▶ Carbon fibre bar 30x10mm, guiding elements made of chromed steel
- ▶ Extremely low weight, high strength of shape
- ▶ Delivered in wooden case incl. 1 pair each sleeves Ø 3.5mm with internal thread M 2.5 and standard measuring inserts boll Ø 3mm

### Funktionen:

- ▶ Ein/Aus
- ▶ mm/inch Umschaltung
- ▶ 0-Punkt an jeder Position
- ▶ ± Preset Funktion
- ▶ Hold Funktion
- ▶ Datenausgang Opto

### Functions:

- ▶ On/Off
- ▶ mm/inch commutation
- ▶ Zero setting at any position
- ▶ ± Preset function
- ▶ Hold function
- ▶ Data output Opto

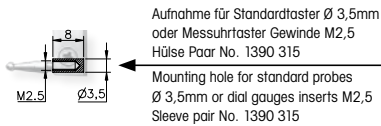

Messeinsätze M 2,5,  
siehe Seite 4. 16  
Measuring inserts M 2.5,  
see page 4. 16



innen / inside mm / inch		außen / outside mm / inch		mm	A mm	mm	inch	kg	Nº
48 - 448	2 - 18	0 - 376	0 - 15	125	12	0,01	.0005	1,0	1854 200
48 - 448	2 - 18	0 - 376	0 - 15	150	12	0,01	.0005	1,02	1854 201
48 - 648	2 - 26	0 - 576	0 - 23	125	12	0,01	.0005	1,15	1854 202
48 - 648	2 - 26	0 - 576	0 - 23	150	12	0,01	.0005	1,17	1854 203
48 - 848	2 - 34	0 - 776	0 - 31	125	12	0,01	.0005	1,28	1854 204
48 - 848	2 - 34	0 - 776	0 - 31	150	12	0,01	.0005	1,3	1854 205
Datenkabel RS232 (2m) / Data cable RS232 (2m)									1850 203
Datenkabel USB (2m) / Data cable USB (2m)									1850 204

## Digital-Messschieber IP 67 für Innennuten und Nutenbreiten

## Digital calipers IP 67 for inside grooves and groove width



No. 1926 201

Nutenbreite  
Croore width

- ▶ Werksnorm
- ▶ Schutzart IP 67, Sylvac System
- ▶ Feststellschraube
- ▶ rostfreier Stahl gehärtet
- ▶ großes LCD Display
- ▶ Lieferung im Etui

- ▶ Works standard
- ▶ Protection class IP 67, Sylvac System
- ▶ Locking screw
- ▶ Hardened stainless steel
- ▶ Large LCD display
- ▶ Delivered in a case

### Funktionen:

- ▶ Ein/Aus
- ▶ mm/inch Umschaltung
- ▶ 0-Punkt an jeder Position
- ▶ Datenausgang Proximity

### Functions:

- ▶ On/Off
- ▶ mm/inch commutation
- ▶ Zero setting at any position
- ▶ Data output Proximity

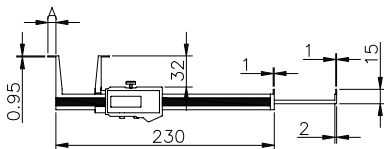

Anwendungsbeispiele  
Example of use



mm		inch		A mm	mm	inch	kg	Nº
10 - 170	.4 - 7	3,5	0,01	.0005	0,22	1926 201		
20 - 180	.8 - 7	8,5	0,01	.0005	0,23	1926 202		
Datenkabel RS232 (2m) / Data cable RS232 (2m)								
Datenkabel USB (2m) / Data cable USB (2m)								

**Digital-Universalmessschieber IP 67 für Innen- und Außenmessung**

**Digital universal calipers IP 67 for inside and outside measurement**







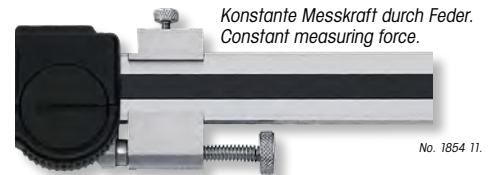

Konstante Messkraft durch Feder.  
Constant measuring force.

- ▶ Werksnorm
- ▶ Schutzart IP67, Sylvac System
- ▶ Feststellschraube
- ▶ rostfreier Stahl gehärtet
- ▶ großes LCD Display
- ▶ Messeinsätze auswechselbar
- ▶ Lieferung im Holzetui inkl. je 1 Paar Hülsen Ø 3,5mm mit Innengewinde M 2,5 und Standard-Messeinsätzen Kugel Ø 3mm

- ▶ Works standard
- ▶ Protection class IP67, Sylvac System
- ▶ Locking screw
- ▶ Hardened stainless steel
- ▶ Large LCD display
- ▶ Interchangeable measuring inserts
- ▶ Delivered in wooden case incl. 1 pair each sleeves Ø 3,5mm with internal thread M 2.5 and standard measuring inserts ball Ø 3mm

**Funktion:**

- ▶ Ein/Aus, mm/inch Umschaltung, O-Punkt an jeder Position, ± Preset Funktion, Hold Funktion, Datenausgang Proximity

**Functions:**

- ▶ On/Off, mm/inch commutation, Zero setting at any position, ± Preset function, Hold function, Data output Proximity

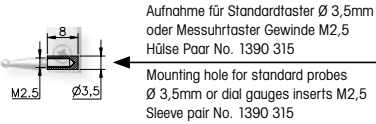

Messeinsätze M 2,5, siehe Seite 4.16  
Measuring inserts M 2.5, see page 4.16



**1854 10. :**  
Ohne konstante Messkraft

**1854 10. :**  
Without constant measuring force

**1854 11. :**  
Mit konstanter Messkraft durch Feder

**1854 11. :**  
With constant measuring force

	innen / inside mm / inch	außen / outside mm / inch	l	A mm	mm <math>\leq</math> inch	kg	Nº		
Ohne konstante Messkraft / Without constant measuring force									
24 - 250	1 - 10	0 - 210	0 - 8,5	64	6,5	0,01	.0005	0,26	<b>1854 100</b>
42 - 400	1,5 - 14	0 - 320	0 - 11	103	9	0,01	.0005	0,56	<b>1854 101</b>
42 - 500	1,5 - 18	0 - 420	0 - 15	103	9	0,01	.0005	0,65	<b>1854 102</b>
Mit konstanter Messkraft durch Feder / With constant measuring force									
24 - 220	1 - 8,5	0 - 170	0 - 6,5	64	6,5	0,01	.0005	0,3	<b>1854 110</b>
42 - 370	1,5 - 12,5	0 - 280	0 - 9	103	9	0,01	.0005	0,63	<b>1854 111</b>
42 - 470	1,5 - 16,5	0 - 380	0 - 13	103	9	0,01	.0005	0,71	<b>1854 112</b>
Datenkabel RS232 (2m) / Data cable RS232 (2m)									<b>1850 203ip</b>
Datenkabel USB (2m) / Data cable USB (2m)									<b>1850 204ip</b>

**Digital-Messschieber für Innennuten**

**Digital calipers for inside grooves**







- ▶ Werksnorm
- ▶ Sylvac System
- ▶ Feststellschraube
- ▶ rostfreier Stahl gehärtet
- ▶ großes LCD Display
- ▶ Lieferung im Etui

- ▶ Works standard
- ▶ Sylvac System
- ▶ Locking screw
- ▶ Hardened stainless steel
- ▶ Large LCD display
- ▶ Delivered in a case

**Funktionen:**

- ▶ Ein/Aus
- ▶ mm/inch Umschaltung
- ▶ O-Punkt an jeder Position
- ▶ Datenausgang Opto

**Functions:**

- ▶ On/Off
- ▶ mm/inch commutation
- ▶ Zero setting at any position
- ▶ Data output Opto

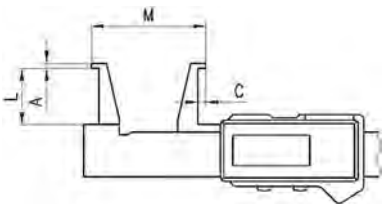

	M <math>l \leq</math>	L mm	A mm	C mm	mm <math>\leq</math> inch	kg	Nº	
10 - 160	.4 - 6	25	0,9	3,0	0,01	.0005	0,15	<b>1926 201s</b>
20 - 160	.8 - 6	40	2,0	5,0	0,01	.0005	0,2	<b>1926 202s</b>
26 - 200	1 - 8	60	3	7	0,01	.0005	0,4	<b>1926 203s</b>
30 - 250	1,2 - 10	80	4	8,5	0,01	.0005	0,45	<b>1926 204s</b>
35 - 300	1,4 - 12	100	5	10	0,01	.0005	0,65	<b>1926 205s</b>
Datenkabel RS232 (2m) / Data cable RS232 (2m)								<b>1850 203</b>
Datenkabel USB (2m) / Data cable USB (2m)								<b>1850 204</b>

**Digital-Universalmessschieber CARBON mit beidseitig verschiebbarem Messschenkel**

**Digital universal calipers CARBON with jaws slidable on both sides**





 ≤3500mm

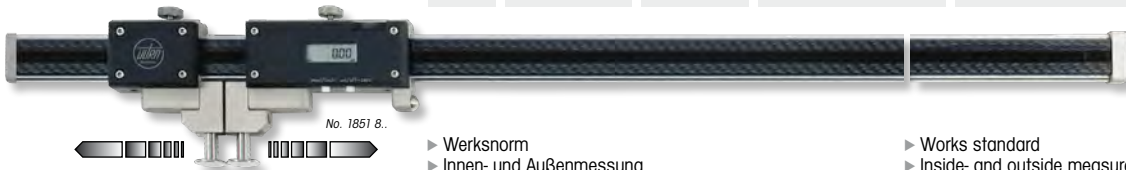

**Gehärtet Hardened**

Messeinsätze Schaft Ø 8mm auswechselbar  
Measuring inserts shaft Ø 8mm interchangeable

Anwendungsbeispiel Bohrungsabstand messen  
Example of use bore distance measurement

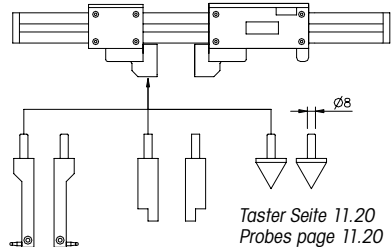

- ▶ Werksnorm
- ▶ Innen- und Außenmessung
- ▶ Schutzart IP 54, Sylvac System
- ▶ Feststellschraube
- ▶ Stange aus Kohlefaser 30x10mm, Führungselemente aus verchromtem Stahl
- ▶ Extrem geringes Gewicht, hohe Formstabilität
- ▶ großes LCD Display
- ▶ Lieferung im Holzetui

**Funktion:**  
▶ Ein/Aus, mm/inch Umschaltung, ± Preset Funktion, O-Punkt an jeder Position, Hold Funktion, Datenausgang Opto

**Anwendung:**  
▶ Durch verschiedene Messtaster (Zubehör) können vielfältige Messaufgaben realisiert werden. z.B. Innen-Außenmessung, Messen von Bohrungsabständen, Nuten und Absätzen.

- ▶ Works standard
- ▶ Inside- and outside measurement
- ▶ Protection class IP 54, Sylvac System
- ▶ Locking screw
- ▶ Carbon fibre bar 30x10mm, guiding elements made of chromed steel
- ▶ Extremely low weight, high strength of shape
- ▶ Large LCD display
- ▶ Delivered in wooden box

**Functions:**  
▶ On/Off, mm/inch commutation, ± preset function, Zero setting at any position, Hold function, Data output Opto

**Application:**  
▶ With different measuring probes (accessories) you can realise various measuring jobs. e.g. inside and outside measurement, measuring of centre distance, grooves and offset surfaces.

mm	inch	mm	mm	inch	kg	Nº
Stangenquerschnitt 30 x 10mm / Bar cross section 30 x 10mm						
400	16	30 x 10	0,01	.0005	0,75	1851 801
600	24	30 x 10	0,01	.0005	0,9	1851 802
800	32	30 x 10	0,01	.0005	1,05	1851 802x
1000	40	30 x 10	0,01	.0005	1,2	1851 803
Stangenquerschnitt 47 x 16mm / Bar cross section 47 x 16mm						
1500	60	47 x 16	0,01	.0005	3,0	1851 804
2000	80	47 x 16	0,01	.0005	3,4	1851 805
2500	100	47 x 16	0,01	.0005	3,8	1851 806
3000	120	47 x 16	0,01	.0005	4,25	1851 807
3500	140	47 x 16	0,01	.0005	4,65	1851 808
> 3500mm auf Anfrage / on request						
Datenkabel RS232 (2m) / Data cable RS232 (2m)						1850 203
Datenkabel USB (2m) / Data cable USB (2m)						1850 204

**Schutzart IP 67 auf Anfrage. / Protection class IP 67 on request.**

**Digital-Messschieber IP 67 für Nutenmessung in Bohrungen**

**Digital calipers IP 67 for groove measure inside bores**



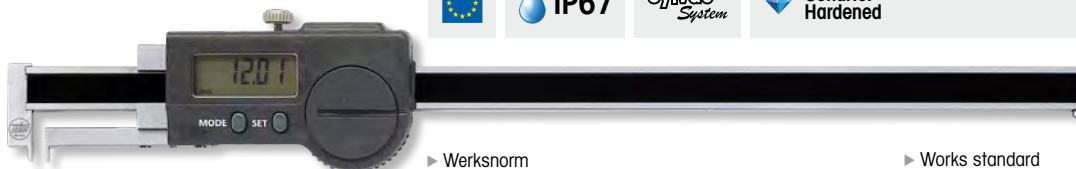

No. 1926 301

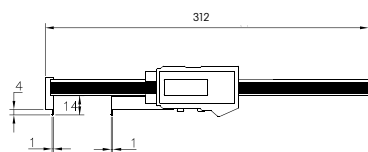

- ▶ Werksnorm
- ▶ Schutzart IP 67, Sylvac System
- ▶ Feststellschraube
- ▶ rostfreier Stahl gehärtet
- ▶ großes LCD Display
- ▶ Lieferung im Etui

**Funktionen:**  
▶ Ein/Aus, mm/inch Umschaltung, O-Punkt an jeder Position, Datenausgang Proximity

- ▶ Works standard
- ▶ Protection class IP 67, Sylvac System
- ▶ Locking screw
- ▶ Hardened stainless steel
- ▶ Large LCD display
- ▶ Delivered in a case

**Functions:**  
▶ On/Off, mm/inch commutation, Zero setting at any position, Data output Proximity

innen / inside mm / inch	außen / outside mm / inch	mm	inch	kg	Nº
2 - 200	0 - 200	0,01	.0005	0,25	1926 301
Datenkabel RS232 (2m) / Data cable RS232 (2m)					1850 203ip
Datenkabel USB (2m) / Data cable USB (2m)					1850 204ip

**Digital-Universalmessschieber CARBON mit beidseitig verschiebbarem Messschenkel und konstanter Messkraft**

**Digital universal calipers CARBON with jaws slidable on both sides and constant measuring force**

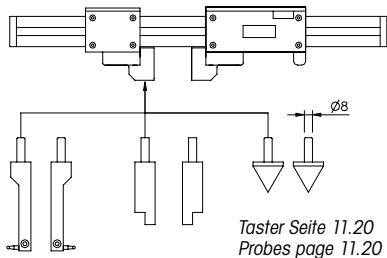
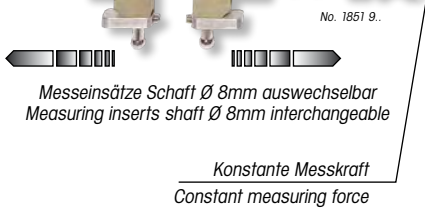

**Anwendung:**  
Durch verschiedene Messtaster (Zubehör) können vielfältige Messaufgaben realisiert werden. z.B. Innen- Außenmessung, Messen von Bohrungsabständen, Nuten und Absätzen.

**Application:**  
With different measuring probes (accessories) you can realise various measuring jobs. e.g. inside and outside measurement, measuring of centre distance, grooves and offset surfaces.

- ▶ Werksnorm
- ▶ Innen- und Außenmessung
- ▶ Vergleichsmessung mit Messuhr
- ▶ Mit konstanter Messkraft durch Feder
- ▶ Schutzart IP 54, Sylvac System
- ▶ Feststellschraube
- ▶ Stange aus Kohlefaser 30x10mm, Führungselemente aus verchromtem Stahl
- ▶ Extrem geringes Gewicht, hohe Formstabilität
- ▶ großes LCD Display
- ▶ Messrichtungsumkehr
- ▶ Messkraft stufenlos einstellbar
- ▶ Messeinsätze auswechselbar
- ▶ Messuhrablesung 0,01mm
- ▶ Toleranzmarken einstellbar
- ▶ Lieferung im Holzetui mit Messuhr

**Funktionen:**

- ▶ Ein/Aus, mm/inch Umschaltung, ± Preset Funktion, O-Punkt an jeder Position, Hold Funktion, Datenausgang Opto

**Handhabung:**

Das Messgerät wird z.B. mit einem Einstellring Ø 50mm voreingestellt in dem die Digitalanzeige mit Preset auf 50mm eingestellt wird und die Messuhr auf den Wert 0 (Umkehrpunkt!). Durch Verfahren des rechten Schiebers kann nun jeder beliebige Messwert innerhalb des gesamten Messbereichs über die Digitalanzeige eingestellt werden. Die Abweichung des Werkstücks zum eingestellten Wert (Digitalanzeige) wird an der Messuhr in 1/100mm abgelesen (Umkehrpunkt!).

**Vorteil:** Ein Einstellmeister reicht aus, um das Gerät, innerhalb des Messbereiches, auf ein beliebiges Werkstückmaß vor einzustellen.

- ▶ Works standard
- ▶ Inside- and outside measurement
- ▶ Comparative measuring with dial gauge
- ▶ With constant measuring force due spring
- ▶ Protection class IP 54, Sylvac System
- ▶ Locking screw
- ▶ Carbon fibre bar 30x10mm, guiding elements made of chromed steel
- ▶ Extremely low weight, high strength of shape
- ▶ Large LCD display
- ▶ Reversible measuring direction
- ▶ Adjustable measuring force
- ▶ Interchangeable measuring inserts
- ▶ Dial gauge reading 0.01mm
- ▶ Adjustable tolerance marks
- ▶ Delivered in wooden case with dial gauge

**Functions:**

- ▶ On/Off, mm/inch commutation, ± preset function, Zero setting at any position, Hold function, Data output Opto

**Operation:**

The setting of the instrument will be made by using for example a Ø 50mm setting ring gauge, the digital display will be preset to the value 50mm and the dial gauge will be adjusted to 0 (reversing point!). By sliding the right jaw (electronic device) you can preset now each value up to the complete measuring range of the instrument – the deviation of your work piece, in comparison to your preset value at your digital display, will be read at the dial gauge in 1/100mm (reversing point!).

**Advantage:** One setting master is sufficient to adjust the instrument and to be able to use it after that for any size within the instrument capacity.

mm	inch	mm	mm	inch	kg	Nº
400	16	30 x 10	0,01	.0005	0,95	1851 901
600	24	30 x 10	0,01	.0005	1,1	1851 902
1000	40	30 x 10	0,01	.0005	1,7	1851 903
Datenkabel RS232 (2m) / Data cable RS232 (2m)						1850 203
Datenkabel USB (2m) / Data cable USB (2m)						1850 204

**Digital-Taschenmessschieber IP 67 für Kegelmessungen**

**Digital pocket calipers IP 67 for conical measurements**



Mit großer 3V Batterie.  
With large 3V battery.

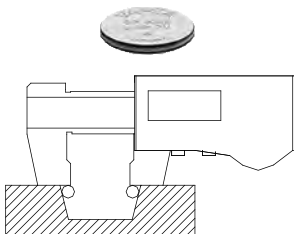

- ▶ Werksnorm
- ▶ Schutzart IP 67, Sylvac System
- ▶ Feststellschraube
- ▶ rostfreier Stahl gehärtet
- ▶ großes LCD Display
- ▶ Tiefenmaß eckig
- ▶ Lieferung im Etui

**Funktionen:**

- ▶ Ein/Aus, Auto-On bei Bewegung, mm/inch Umschaltung, O-Punkt an jeder Position, ABS Funktion (fester O-Punkt), Datenausgang Proximity

- ▶ Works standard
- ▶ Protection class IP 67, Sylvac System
- ▶ Locking screw
- ▶ Hardened stainless steel
- ▶ Large LCD display
- ▶ Depth gauge angular
- ▶ Delivered in a case

**Functions:**

- ▶ On/Off, Auto-On by sliding, mm/inch commutation, Zero setting at any position, ABS function (fixed 0 point), Data output Proximity

innen / inside mm / inch	außen / outside mm / inch	mm	inch	kg	Nº
10 – 150 .5 – 6	0 – 150 0 – 6	0,01	.0005	0,18	1850 641
Datenkabel RS232 (2m) / Data cable RS232 (2m)					1850 203ip
Datenkabel USB (2m) / Data cable USB (2m)					1850 204ip

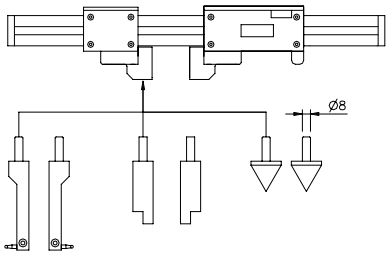

**Messeinsätze für ULTRA Universalmessgeräte mit Einspannschaft Ø 8mm, Paar**

**Probes for ULTRA universal calipers with clamping shaft Ø 8mm, pair**



**Gehärtet  
Hardened**

- ▶ aus gehärtetem Spezialstahl
- ▶ Lieferung paarweise verpackt

- ▶ Hardened special steel
- ▶ Delivered in a package (pair)

**1** Andere Messtaster auf Anfrage.

**1** Other measurings inserts on request.

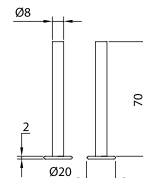
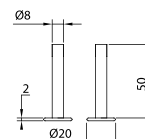
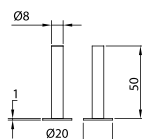
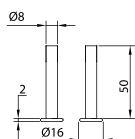
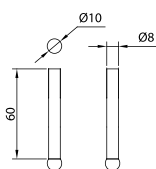
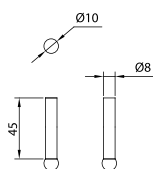

**Nº 1390 301**

**1390 302**

**1390 303**

**1390 312**

**1390 313**

**1390 304**

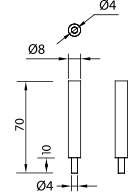
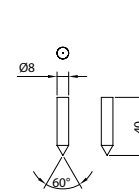
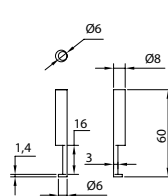
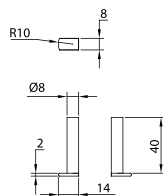
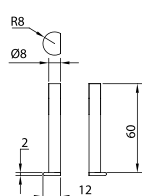
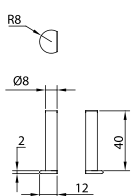

**Nº 1390 305**

**1390 306**

**1390 307**

**1390 308**

**1390 309**

**1390 314**

Aufnahme für Standardtaster Ø 3,5mm oder Messuhrfeder Gewinde M2,5  
Mounting hole for standard probes Ø 3,5mm or dial gauges inserts M2,5

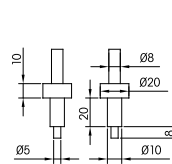
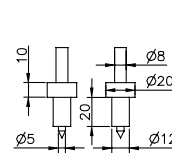
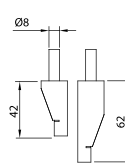
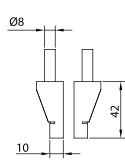
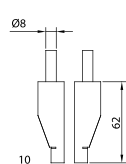

**Nº 1851 810**

**1851 812**

**1851 813**

**1851 814**

**1851 816**

**1851 818**

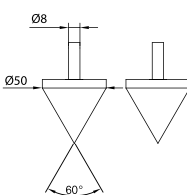
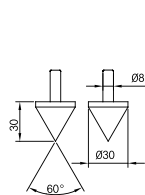
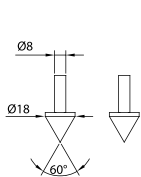

Taster für Gewindemessung auf Anfrage.

Probes for thread measurement on request.

**Nº 1851 819**

**1851 815**

**1851 820**



No. 1390 351

**Tablett für Messtaster**

**Tray for measuring probes**



- ▶ zur Aufbewahrung von max. 12 Tastern
- ▶ aus Plexiglas
- ▶ Bohrungen für Schaft Ø 8mm
- ▶ Lieferung einzeln verpackt, ohne Taster

- ▶ For storing of max. 12 probes
- ▶ Made of plexiglass
- ▶ Holes for shaft Ø 8mm
- ▶ Delivered in individual packages

L mm	kg	Nº
150 x 100 x 25	0,1	1390 351



## Digital-Messschieber CARBON mit beidseitig verschiebbarem Messschenkel und zylindrischen Messzapfen Ø 5mm

## Digital calipers CARBON with jaws slideable on both sides and cylindrical measuring pins Ø 5mm

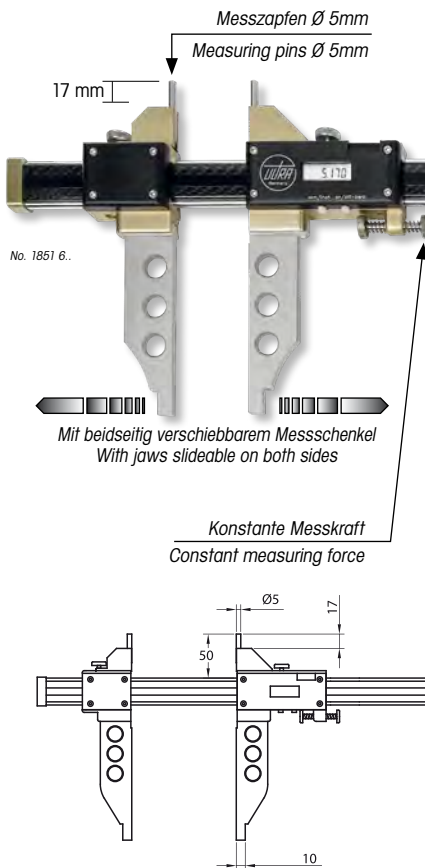







Stangenquerschnitt  
Bar cross section  
30x10mm

- ▶ Werksnorm
- ▶ Schutzart IP 54, Sylvac System
- ▶ Feststellschraube und Feineinstellung
- ▶ Mit konstanter Messkraft durch Feder
- ▶ Stange aus Kohlefaser 30x10mm, Führungselemente aus verchromtem Stahl
- ▶ Messflächen aus rostfreiem Stahl
- ▶ Extrem geringes Gewicht, hohe Formstabilität
- ▶ großes LCD Display
- ▶ Lieferung im Holzetui

### Funktionen:

- ▶ Ein/Aus, mm/inch Umschaltung, ± Preset Funktion, O-Punkt an jeder Position, Hold Funktion, Datenausgang Opto

1 Größere Messbereiche auf Anfrage.

mm	inch	mm	mm	inch	mm	kg	Nº
500	20	125	0,01	.0005	0,03	1,1	1851 601
500	20	150	0,01	.0005	0,03	1,12	1851 602
600	24	125	0,01	.0005	0,03	1,16	1851 603
600	24	150	0,01	.0005	0,03	1,18	1851 604

Datenkabel RS232 (2m) / Data cable RS232 (2m)

Datenkabel USB (2m) / Data cable USB (2m)

- ▶ Works standard
- ▶ Protection class IP 54, Sylvac System
- ▶ Locking screw and fine adjustment
- ▶ With constant measuring force due spring
- ▶ Carbon fibre bar 30x10mm, guiding elements made of chromed steel
- ▶ Measuring faces made of stainless steel
- ▶ Extremely low weight, high strength of shape
- ▶ Large LCD display
- ▶ Delivered in wooden box

### Functions:

- ▶ On/Off, mm/inch commutation, ± preset function, Zero setting at any position, Hold function, Data output Opto

1 Larger measuring ranges on request.

mm	inch	mm	mm	inch	mm	kg	Nº
800	30	125	0,01	.0005	0,04	1,28	1851 605
800	30	150	0,01	.0005	0,04	1,3	1851 606
1000	40	125	0,01	.0005	0,04	1,4	1851 607
1000	40	150	0,01	.0005	0,04	1,42	1851 608

1850 203

1850 204

**Schutzart IP 67 auf Anfrage. / Protection class IP 67 on request.**

## Digital-Messschieber, IP67 CARBON mit zylindrischen Messzapfen Ø5mm

## Digital calipers, IP67 CARBON with cylindrical measuring pins Ø5mm

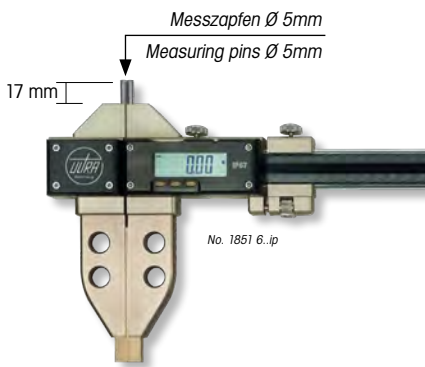







Stangenquerschnitt  
Bar cross section  
30x10mm

- ▶ Werksnorm
- ▶ Schutzart IP 67, Sylvac System
- ▶ Feststellschraube und Feineinstellung
- ▶ Stange aus Kohlefaser 30x10mm, Führungselemente aus verchromtem Stahl
- ▶ Messflächen aus rostfreiem Stahl, TIN beschichtet
- ▶ Extrem geringes Gewicht, hohe Formstabilität
- ▶ großes LCD Display
- ▶ Lieferung im Holzetui

### Funktionen:

- ▶ Ein/Aus, mm/inch Umschaltung, O-Punkt an jeder Position, Hold Funktion, Datenausgang Proximity

- ▶ Works standard
- ▶ Protection class IP 67, Sylvac System
- ▶ Locking screw and fine adjustment
- ▶ Carbon fibre bar 30x10mm, guiding elements made of chromed steel
- ▶ Measuring faces made of stainless steel, TIN coated
- ▶ Extremely low weight, high strength of shape
- ▶ Large LCD display
- ▶ Delivered in wooden box

### Functions:

- ▶ On/Off, mm/inch commutation, Zero setting at any position, Hold function, Data output Proximity

mm	inch	mm	mm	inch	mm	kg	Nº
500	20	100	0,01	.0005	0,03	1,02	1851 651ip
500	20	125	0,01	.0005	0,03	1,1	1851 652ip
500	20	150	0,01	.0005	0,03	1,12	1851 653ip
500	20	200	0,01	.0005	0,03	1,22	1851 654ip
600	24	100	0,01	.0005	0,03	1,08	1851 655ip
600	24	125	0,01	.0005	0,03	1,16	1851 656ip
600	24	150	0,01	.0005	0,03	1,18	1851 657ip
600	24	200	0,01	.0005	0,03	1,28	1851 658ip

Datenkabel RS232 (2m) / Data cable RS232 (2m)

Datenkabel USB (2m) / Data cable USB (2m)

1850 203

1850 204

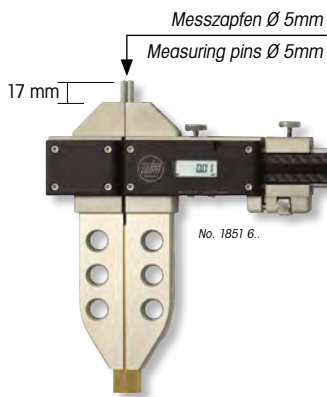

## Digital-Messschieber CARBON mit zylindrischen Messzapfen Ø5mm

## Digital calipers CARBON with cylindrical measuring pins Ø5mm



Stangenquerschnitt  
Bar cross section  
30x10mm

- ▶ Werksnorm
- ▶ Schutzart IP 54, Sylvac System
- ▶ Feststellschraube und Feineinstellung
- ▶ Stange aus Kohlefaser 30x10mm, Führungselemente aus verchromtem Stahl
- ▶ Messflächen aus rostfreiem Stahl, TIN beschichtet
- ▶ Extrem geringes Gewicht, hohe Formstabilität
- ▶ großes LCD Display
- ▶ Lieferung im Holzetui

- ▶ Works standard
- ▶ Protection class IP 54, Sylvac System
- ▶ Locking screw and fine adjustment
- ▶ Carbon fibre bar 30x10mm, guiding elements made of chromed steel
- ▶ Measuring faces made of stainless steel, TIN coated
- ▶ Extremely low weight, high strength of shape
- ▶ Large LCD display
- ▶ Delivered in wooden box

### Funktionen:

- ▶ Ein/Aus, mm/inch Umschaltung, 0-Punkt an jeder Position, Hold Funktion, Datenausgang Opto

### Functions:

- ▶ On/Off, mm/inch commutation, Zero setting at any position, Hold function, Data output Opto

mm	inch	mm	mm	mm	inch	mm	kg	Nº
500	20	100	30x10	0,01	.0005	0,03	1,02	1851 651
500	20	125	30x10	0,01	.0005	0,03	1,1	1851 652
500	20	150	30x10	0,01	.0005	0,03	1,12	1851 653
500	20	200	30x10	0,01	.0005	0,03	1,22	1851 654
600	24	100	30x10	0,01	.0005	0,03	1,08	1851 655
600	24	125	30x10	0,01	.0005	0,03	1,16	1851 656
600	24	150	30x10	0,01	.0005	0,03	1,18	1851 657
600	24	200	30x10	0,01	.0005	0,03	1,28	1851 658
800	32	100	30x10	0,01	.0005	0,03	1,2	1851 659
800	32	125	30x10	0,01	.0005	0,04	1,28	1851 660
800	32	150	30x10	0,01	.0005	0,04	1,3	1851 661
800	32	200	30x10	0,01	.0005	0,04	1,4	1851 662
1000	40	100	30x10	0,01	.0005	0,04	1,32	1851 663
1000	40	125	30x10	0,01	.0005	0,04	1,4	1851 664
1000	40	150	30x10	0,01	.0005	0,04	1,42	1851 665
1000	40	200	30x10	0,01	.0005	0,04	1,52	1851 666

Werkstückauflage für festen Schnabel / Support for fixed jaw

1851 751

Werkstückauflage für verschiebbaren Schnabel / Support for slideable jaw

1851 752

Schnabel 150mm für Messuhr Ø 8mm / Jaw 150mm for dial gauges Ø 8mm

1851 754

Schnabel 200mm für Messuhr Ø 8mm / Jaw 200mm for dial gauges Ø 8mm

1851 755

Datenkabel RS232 (2m) / Data cable RS232 (2m)

1850 203

Datenkabel USB (2m) / Data cable USB (2m)

1850 204

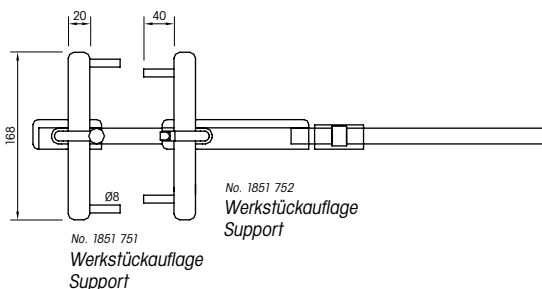
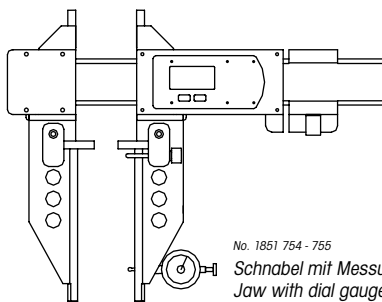

Anwendungsbeispiele  
Werkstückauflage

Examples  
of use Support



## Digital-Messschieber CARBON mit Messerspitzen

## Digital calipers CARBON with knife points





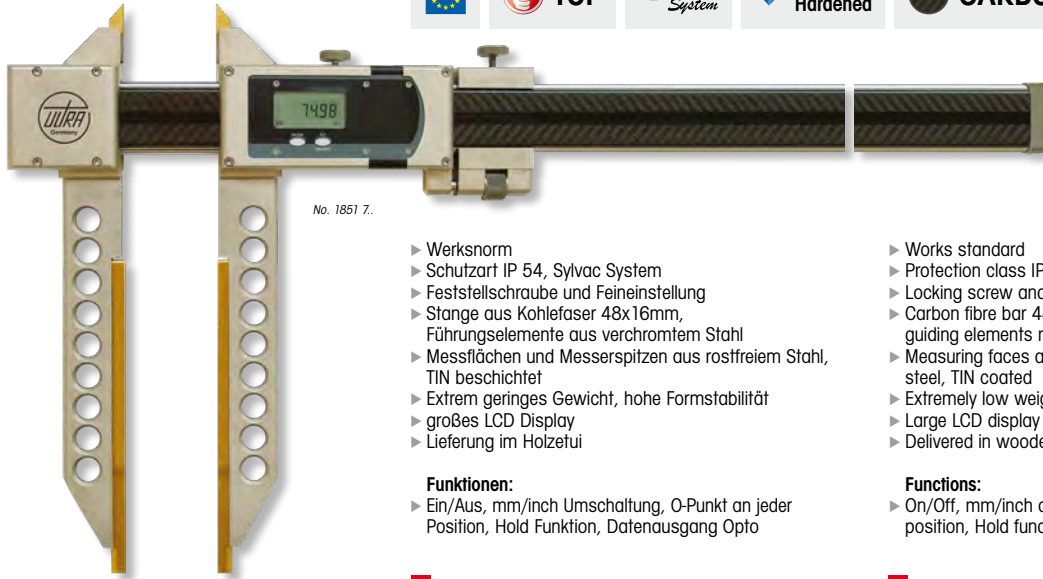

No. 1851 7.

- ▶ Werknorm
- ▶ Schutzart IP 54, Sylvac System
- ▶ Feststellschraube und Feineinstellung
- ▶ Stange aus Kohlefaser 48x16mm, Führungselemente aus verchromtem Stahl
- ▶ Messflächen und Messerspitzen aus rostfreiem Stahl, TIN beschichtet
- ▶ Extrem geringes Gewicht, hohe Formstabilität
- ▶ großes LCD Display
- ▶ Lieferung im Holzetui

### Funktionen:

- ▶ Ein/Aus, mm/inch Umschaltung, 0-Punkt an jeder Position, Hold Funktion, Datenausgang Opto

- ▶ Works standard
- ▶ Protection class IP 54, Sylvac System
- ▶ Locking screw and fine adjustment
- ▶ Carbon fibre bar 48x16mm, guiding elements made of chromed steel
- ▶ Measuring faces and knife points made of stainless steel, TIN coated
- ▶ Extremely low weight, high strength of shape
- ▶ Large LCD display
- ▶ Delivered in wooden box

### Functions:

- ▶ On/Off, mm/inch commutation, Zero setting at any position, Hold function, Data output Opto

**1** Bei Bestellung Spitzenform angeben - als Standard wird Form A geliefert. Andere Größen und Schnabellängen auf Anfrage.

**1** Specify point type in order - standard supply with type A. Other sizes and jaw lengths on request.

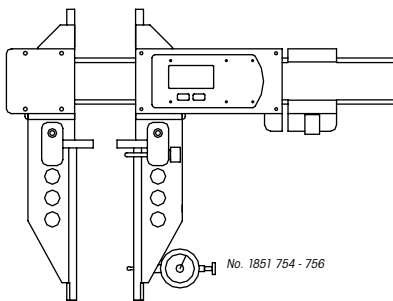
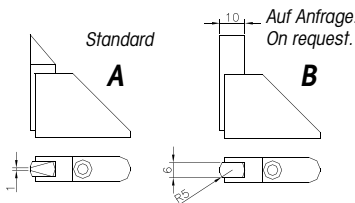

Schnabel mit Messuhraufnahme Ø 8mm  
Jaw with dial gauge hole Ø 8mm

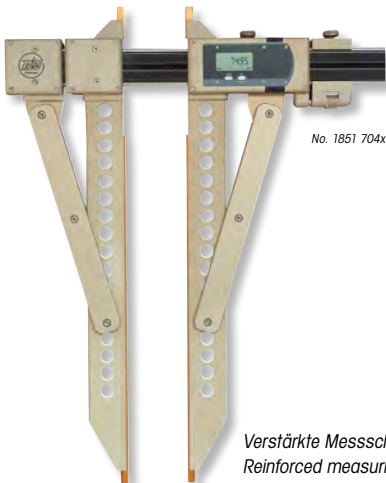

Verstärkte Messschnäbel ab 500mm  
Reinforced measuring jaws from 500mm

No. 1851 704x

mm	inch	mm	mm	mm	inch	mm	kg	Nº
Einfache Führungsstange 48x16mm / Standard bar 48x16mm								
1000	40	150	48x16	0,01	.0005	0,03	2,5	1851 701
1000	40	200	48x16	0,01	.0005	0,03	2,6	1851 702
1000	40	300	48x16	0,01	.0005	0,03	2,8	1851 703
1000	40	500	48x16	0,01	.0005	0,04	3,2	1851 704
1500	60	150	48x16	0,01	.0005	0,05	3,2	1851 704x
1500	60	200	48x16	0,01	.0005	0,05	3,3	1851 705
1500	60	300	48x16	0,01	.0005	0,06	3,5	1851 706
1500	60	500	48x16	0,01	.0005	0,06	3,9	1851 706x
2000	80	150	48x16	0,01	.0005	0,06	3,3	1851 707x
2000	80	200	48x16	0,01	.0005	0,06	3,5	1851 707
2000	80	300	48x16	0,01	.0005	0,07	3,7	1851 708
2000	80	500	48x16	0,01	.0005	0,07	4,1	1851 708x
2500	100	200	48x16	0,01	.0005	0,07	3,7	1851 709
2500	100	300	48x16	0,01	.0005	0,08	3,9	1851 710
3000	120	200	48x16	0,01	.0005	0,08	4,0	1851 711
3000	120	300	48x16	0,01	.0005	0,09	4,2	1851 712
3500	138	200	48x16	0,01	.0005	0,10	4,9	1851 713
3500	138	300	48x16	0,01	.0005	0,10	5,1	1851 714
Doppelte Führungsstange 48x38mm / Double bar 48x38mm								
4000	157	200	48x38	0,01	.0005	0,12	5,8	1851 715
4000	157	300	48x38	0,01	.0005	0,12	6,0	1851 716
4500	178	200	48x38	0,01	.0005	0,15	6,5	1851 717
4500	178	300	48x38	0,01	.0005	0,15	6,7	1851 718
5000	197	200	48x38	0,01	.0005	0,18	7,2	1851 719
5000	197	300	48x38	0,01	.0005	0,18	7,4	1851 720
Werkstückauflage für festen Schnabel / Support for fixed jaw								1851 751
Werkstückauflage für verschiebbaren Schnabel / Support for slideable jaw								1851 752
Schnabel 150mm für Messuhr Ø 8mm / Jaw 150mm for dial gauges Ø 8mm								1851 754
Schnabel 200mm für Messuhr Ø 8mm / Jaw 200mm for dial gauges Ø 8mm								1851 755
Schnabel 300mm für Messuhr Ø 8mm / Jaw 300mm for dial gauges Ø 8mm								1851 756
Datenkabel RS232 (2m) / Data cable RS232 (2m)								1850 203
Datenkabel USB (2m) / Data cable USB (2m)								1850 204

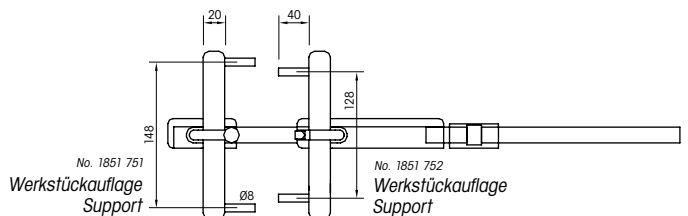

**Digital-Messschieber, IP 67**  
**Präzisionsausführung ohne Spitzen**

**Digital calipers, IP 67**  
**Precision model without points**

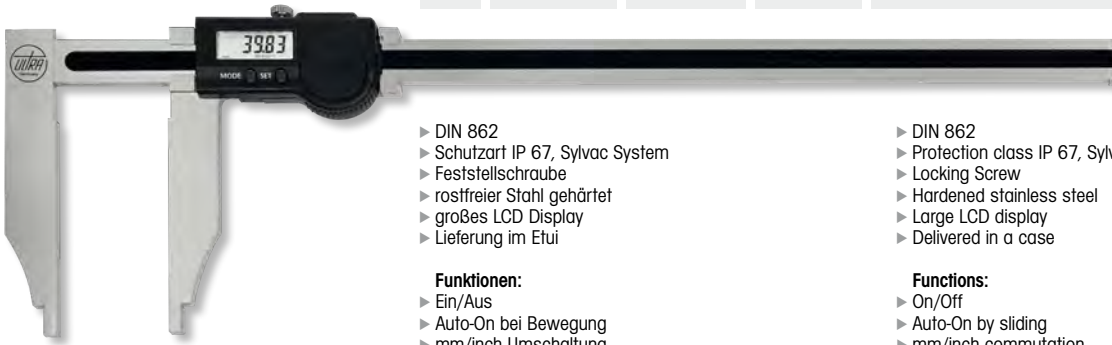

No. 1851 15.ip

- ▶ DIN 862
- ▶ Schutzart IP 67, Sylvac System
- ▶ Feststellschraube
- ▶ rostfreier Stahl gehärtet
- ▶ großes LCD Display
- ▶ Lieferung im Etui

**Funktionen:**

- ▶ Ein/Aus
- ▶ Auto-On bei Bewegung
- ▶ mm/inch Umschaltung
- ▶ 0-Punkt an jeder Position
- ▶ Lock Funktion (fester 0-Punkt), absolutes System
- ▶ Datenausgang Proximity

- ▶ DIN 862
- ▶ Protection class IP 67, Sylvac System
- ▶ Locking Screw
- ▶ Hardened stainless steel
- ▶ Large LCD display
- ▶ Delivered in a case

**Functions:**

- ▶ On/Off
- ▶ Auto-On by sliding
- ▶ mm/inch commutation
- ▶ Zero setting at any position
- ▶ Lock function (fixed 0 point), absolute system
- ▶ Data output Proximity

mm	inch	mm	mm	inch	kg	Nº
300	12	100	0,01	.0005	0,72	1851 151ip
400	16	100	0,01	.0005	0,82	1851 152ip
500	20	100	0,01	.0005	0,92	1851 153ip
600	24	150	0,01	.0005	2,6	1851 154ip
800	32	150	0,01	.0005	2,9	1851 155ip
1000	40	150	0,01	.0005	3,3	1851 156ip
Datenkabel RS232 (2m) / Data cable RS232 (2m)						1850 203ip
Datenkabel USB (2m) / Data cable USB (2m)						1850 204ip

**Digital-Messschieber, IP 67**  
**Präzisionsausführung mit Spitzen**

**Digital calipers, IP 67**  
**Precision model with points**



No. 1851 16.ip

- ▶ DIN 862
- ▶ Schutzart IP 67, Sylvac System
- ▶ Feststellschraube
- ▶ rostfreier Stahl gehärtet
- ▶ großes LCD Display
- ▶ Lieferung im Etui

**Funktionen:**

- ▶ Ein/Aus
- ▶ Auto-On bei Bewegung
- ▶ mm/inch Umschaltung
- ▶ 0-Punkt an jeder Position
- ▶ Lock Funktion (fester 0-Punkt), absolutes System
- ▶ Datenausgang Proximity

- ▶ DIN 862
- ▶ Protection class IP 67, Sylvac System
- ▶ Locking Screw
- ▶ Hardened stainless steel
- ▶ Large LCD display
- ▶ Delivered in a case

**Functions:**

- ▶ On/Off
- ▶ Auto-On by sliding
- ▶ mm/inch commutation
- ▶ Zero setting at any position
- ▶ Lock function (fixed 0 point), absolute system
- ▶ Data output Proximity

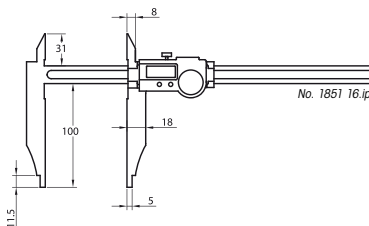

mm	inch	mm	mm	inch	kg	Nº
300	12	100	0,01	.0005	0,72	1851 161ip
400	16	100	0,01	.0005	0,82	1851 162ip
500	20	100	0,01	.0005	0,92	1851 163ip
Datenkabel RS232 (2m) / Data cable RS232 (2m)						1850 203ip
Datenkabel USB (2m) / Data cable USB (2m)						1850 204ip

**Digital-Messschieber mit Kreuzspitzen und langen Schnäbeln, IP 54**

**Digital calipers with cross points and long jaws, IP 54**

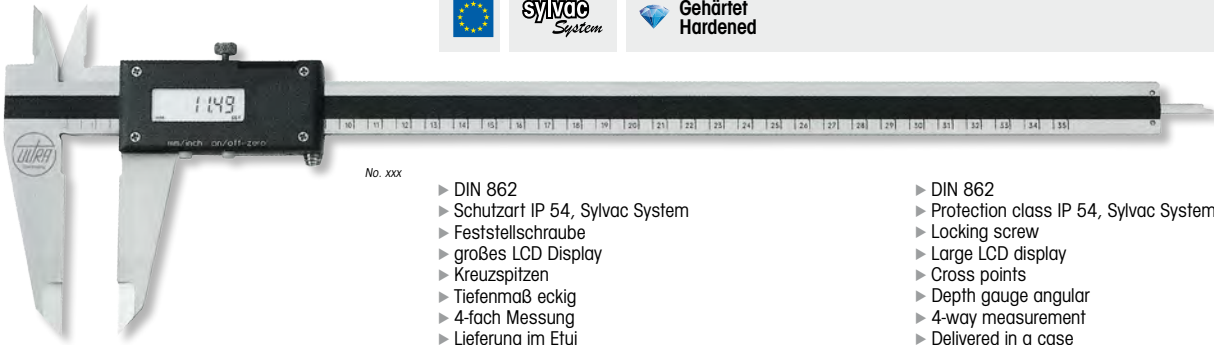

No. xxx

- ▶ DIN 862
- ▶ Schutzart IP 54, Sylvac System
- ▶ Feststellschraube
- ▶ großes LCD Display
- ▶ Kreuzspitzen
- ▶ Tiefenmaß eckig
- ▶ 4-fach Messung
- ▶ Lieferung im Etui

**Funktionen:**

- ▶ Ein/Aus
- ▶ Auto-On bei Bewegung
- ▶ mm/inch Umschaltung
- ▶ 0-Punkt an jeder Position
- ▶ ABS Funktion ( fester 0-Punkt )
- ▶ Datenausgang Opto

- ▶ DIN 862
- ▶ Protection class IP 54, Sylvac System
- ▶ Locking screw
- ▶ Large LCD display
- ▶ Cross points
- ▶ Depth gauge angular
- ▶ 4-way measurement
- ▶ Delivered in a case

**Funktionen:**

- ▶ On/Off
- ▶ Auto-On by sliding
- ▶ mm/inch commutation
- ▶ Zero setting at any position
- ▶ ABS function (fixed 0 point)
- ▶ Data output Opto

**1851 1.. :**  
Mit Messflächen aus rostfreiem Stahl gehärtet

**1851 1.. :**  
Hardened stainless steel measuring faces

**1851 11. :**  
Messflächen hartmetallbestückt

**1851 11. :**  
Tungsten caride-tipped measuring faces

Hartmetall  
Tungsten carbide

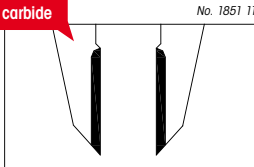

No. 1851 11.

mm	inch	mm	mm	inch	kg	Nº	Nº
250	10	70	0,01	.0005	0,31	1851 101	1851 111
300	12	70	0,01	.0005	0,38	1851 102	1851 112
400	16	70	0,01	.0005	0,42	1851 103	1851 113

Datenkabel RS232 (2m) / Data cable RS232 (2m)

1850 203

Datenkabel USB (2m) / Data cable USB (2m)

1850 204

**Digital-Messschieber ohne Spitzen mit langen Schnäbeln**

**Digital calipers without points with long jaws**

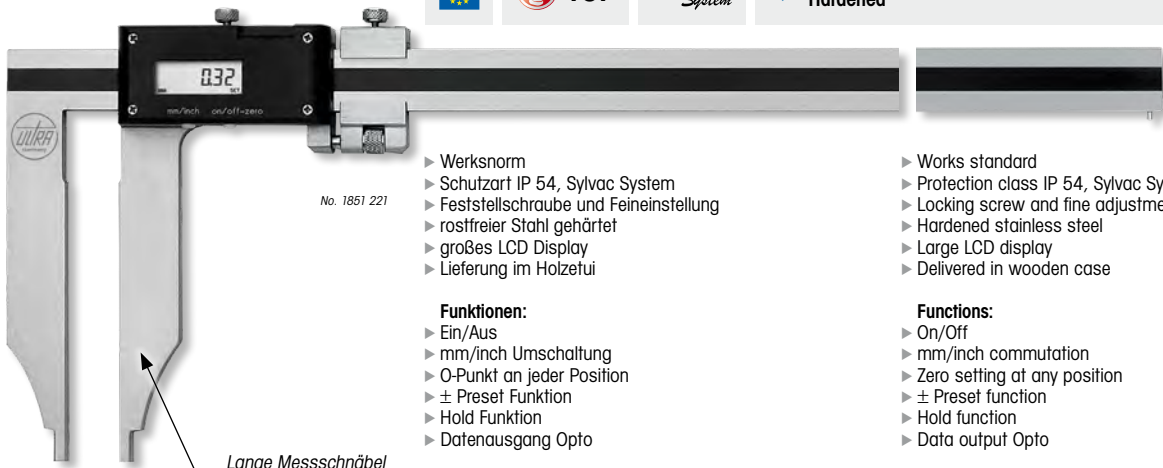

No. 1851 221

- ▶ Werknorm
- ▶ Schutzart IP 54, Sylvac System
- ▶ Feststellschraube und Feineinstellung
- ▶ rostfreier Stahl gehärtet
- ▶ großes LCD Display
- ▶ Lieferung im Holzetui

**Funktionen:**

- ▶ Ein/Aus
- ▶ mm/inch Umschaltung
- ▶ 0-Punkt an jeder Position
- ▶ ± Preset Funktion
- ▶ Hold Funktion
- ▶ Datenausgang Opto

- ▶ Works standard
- ▶ Protection class IP 54, Sylvac System
- ▶ Locking screw and fine adjustment
- ▶ Hardened stainless steel
- ▶ Large LCD display
- ▶ Delivered in wooden case

**Funktionen:**

- ▶ On/Off
- ▶ mm/inch commutation
- ▶ Zero setting at any position
- ▶ ± Preset function
- ▶ Hold function
- ▶ Data output Opto

Lange Messschnäbel  
Long measuring jaws

mm	inch	mm	mm	inch	kg	Nº
500	20	200	0,01	.0005	2,05	1851 221
600	24	250	0,01	.0005	2,55	1851 222
600	24	300	0,01	.0005	2,85	1851 223
1000	40	300	0,01	.0005	5,67	1851 225

Datenkabel RS232 (2m) / Data cable RS232 (2m)

1850 203

Datenkabel USB (2m) / Data cable USB (2m)

1850 204

**Schutzart IP 67 auf Anfrage. / Protection class IP 67 on request.**

## Digital-Universalmessschieber ALINOX mit beidseitig verschiebbarem Messschenkel

## Digital universal calipers ALINOX with jaws slidable on both sides







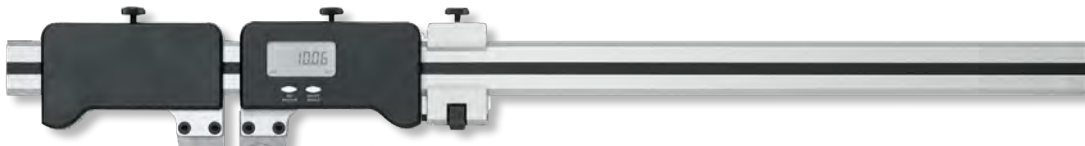

No. 1860 8.



Mit beidseitig verschiebbarem Messschenkel  
With jaws slideable on both sides

- ▶ Werksnorm (Werkstattqualität)
- ▶ Innen- und Außenmessung
- ▶ Schutzart IP 54, Sylvac System
- ▶ Feststellschraube und Feineinstellung
- ▶ Stange 36x9mm und Führungselemente aus Aluminium
- ▶ Schnäbel aus rostfreiem Stahl gehärtet
- ▶ Extrem geringes Gewicht
- ▶ großes LCD Display
- ▶ Lieferung ab Messbereich 1000mm im Holzkasten

### Funktionen:

- ▶ Ein/Aus, mm/inch Umschaltung, ± Preset Funktion, 0-Punkt an jeder Position, Hold Funktion, Datenausgang Opto

! Andere Größen und größere Schnabellängen auf Anfrage.

- ▶ Works standard (workshop quality)
- ▶ Inside- and outside measurement
- ▶ Protection class IP 54, Sylvac System
- ▶ Locking screw and fine adjustment
- ▶ Bar 36x9mm and guiding elements made of aluminium
- ▶ Jaws made of hardened stainless steel
- ▶ Extremely low weight
- ▶ Large LCD display
- ▶ Delivered from measuring range 1000mm in storage box

### Functions:

- ▶ On/Off, mm/inch commutation, ± preset function, zero setting at any position, hold function, data output opto

! Other sizes and larger jaw lengths on request.

mm	inch	mm	mm	inch	kg	Nº	mm	inch	mm	mm	inch	kg	Nº
500	20	150	0,01	.0005	1,0	1860 801	2000	80	150	0,01	.0005	2,2	1860 810
500	20	300	0,01	.0005	1,3	1860 802	2000	80	300	0,01	.0005	2,5	1860 811
500	20	500	0,01	.0005	1,7	1860 803	2000	80	500	0,01	.0005	2,9	1860 812
1000	40	150	0,01	.0005	1,4	1860 804	2500	100	150	0,01	.0005	2,6	1860 813
1000	40	300	0,01	.0005	1,7	1860 805	2500	100	300	0,01	.0005	2,9	1860 814
1000	40	500	0,01	.0005	2,1	1860 806	2500	100	500	0,01	.0005	3,4	1860 815
1500	60	150	0,01	.0005	1,8	1860 807	3000	120	150	0,01	.0005	3,0	1860 816
1500	60	300	0,01	.0005	2,1	1860 808	3000	120	300	0,01	.0005	3,3	1860 817
1500	60	500	0,01	.0005	2,5	1860 809	3000	120	500	0,01	.0005	3,8	1860 818
Datenkabel RS232 (2m) / Data cable RS232 (2m)													1850 203
Datenkabel USB (2m) / Data cable USB (2m)													1850 204

## Digital-Messschieber ALINOX

## Digital calipers ALINOX









No. 1860 1.

- ▶ Werksnorm (Werkstattqualität)
- ▶ Schutzart IP 54, Sylvac System
- ▶ Feststellschraube und Feineinstellung
- ▶ Stange 36x9mm und Führungselemente aus Aluminium
- ▶ Schnäbel aus rostfreiem Stahl gehärtet
- ▶ Extrem geringes Gewicht
- ▶ großes LCD Display
- ▶ Lieferung ab Messbereich 1000mm im Holzkasten

### Funktionen:

- ▶ Ein/Aus, mm/inch Umschaltung, ± Preset Funktion, 0-Punkt an jeder Position, Hold Funktion, Datenausgang Opto

! Andere Größen und größere Schnabellängen auf Anfrage.

- ▶ Works standard (workshop quality)
- ▶ Protection class IP 54, Sylvac System
- ▶ Locking screw and fine adjustment
- ▶ Bar 36x9mm and guiding elements made of aluminium
- ▶ Jaws made of hardened stainless steel
- ▶ Extremely low weight
- ▶ Large LCD display
- ▶ Delivered from measuring range 1000mm in storage box

### Functions:

- ▶ On/Off, mm/inch commutation, ± preset function, zero setting at any position, hold function, data output opto

! Other sizes and larger jaw lengths on request.

mm	inch	mm	mm	inch	kg	Nº	mm	inch	mm	mm	inch	kg	Nº
500	20	150	0,01	.0005	1,0	1860 101	2000	80	150	0,01	.0005	2,2	1860 110
500	20	300	0,01	.0005	1,3	1860 102	2000	80	300	0,01	.0005	2,5	1860 111
500	20	500	0,01	.0005	1,7	1860 103	2000	80	500	0,01	.0005	2,9	1860 112
1000	40	150	0,01	.0005	1,4	1860 104	2500	100	150	0,01	.0005	2,6	1860 113
1000	40	300	0,01	.0005	1,7	1860 105	2500	100	300	0,01	.0005	2,9	1860 114
1000	40	500	0,01	.0005	2,1	1860 106	2500	100	500	0,01	.0005	3,3	1860 115
1500	60	150	0,01	.0005	1,8	1860 107	3000	120	150	0,01	.0005	3,0	1860 116
1500	60	300	0,01	.0005	2,1	1860 108	3000	120	300	0,01	.0005	3,3	1860 117
1500	60	500	0,01	.0005	2,5	1860 109	3000	120	500	0,01	.0005	3,7	1860 118
Datenkabel RS232 (2m) / Data cable RS232 (2m)													1850 203
Datenkabel USB (2m) / Data cable USB (2m)													1850 204

## Digital-Werkstattmessschieber STANDARD

## Digital workshop calipers STANDARD



**Gehärtet  
Hardened**

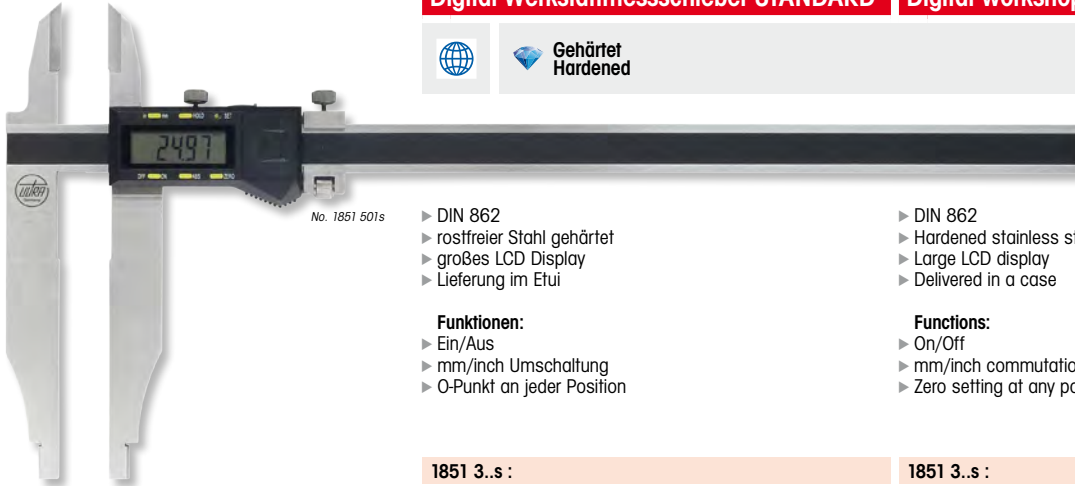

- ▶ DIN 862
- ▶ rostfreier Stahl gehärtet
- ▶ großes LCD Display
- ▶ Lieferung im Etui

**Funktionen:**

- ▶ Ein/Aus
- ▶ mm/inch Umschaltung
- ▶ O-Punkt an jeder Position

- ▶ DIN 862
- ▶ Hardened stainless steel
- ▶ Large LCD display
- ▶ Delivered in a case

**Functions:**

- ▶ On/Off
- ▶ mm/inch commutation
- ▶ Zero setting at any position

**1851 3..s :**  
ohne Spitzen, mit Feineinstellung

**1851 3..s :**  
Without points, with fine adjustment

**1851 5..s :**  
mit Spitzen, mit Feineinstellung

**1851 5..s :**  
With points and fine adjustment

! Größere Messbereiche auf Anfrage.

! Larger measuring ranges on request.

mm	inch	mm	mm	inch	kg	Nº	Nº
Lochmaßansatz Ø 10mm / Nib for inside measurement Ø 10mm							
300	12	90	0,01	.0005	1,1	1851 301s	1851 501s
Lochmaßansatz Ø 20mm / Nib for inside measurement Ø 20mm							
500	20	150	0,01	.0005	2,5	1851 302s	1851 502s
1000	40	150	0,01	.0005	4,5	1851 304s	1851 504s

> 1000mm auf Anfrage / on request



## Messschieber parallaxfreie Ablesung

## Vernier calipers parallax free reading



**Gehärtet  
Hardened**



- ▶ DIN 862
- ▶ Feststellschraube
- ▶ rostfreier Stahl gehärtet
- ▶ Ableseteile mattverchromt, Teilung und Nonius auf einer Ebene
- ▶ Teilung oben, Innenmessung
- ▶ Teilung unten, Aussenmessung
- ▶ Lochmaßansatz Ø 10mm
- ▶ Lieferung einzeln verpackt

- ▶ DIN 862
- ▶ Locking screw
- ▶ Hardened stainless steel
- ▶ Satin chrome reading parts; scale and vernier on one level
- ▶ Upper scale for internal measurement
- ▶ Lower scale for external measurement
- ▶ Nibs for inside measurement Ø 10 mm
- ▶ Delivered in individual packages

**1880 1.. :**  
mit Spitzen

**1880 1.. :**  
With points

**1880 2.. :**  
mit Spitzen, mit Feineinstellung

**1880 2.. :**  
With points and fine adjustment



**1878 2.. :**  
Holzetui

**1878 2.. :**  
Wooden box

! Nonius 1/50mm auf Anfrage.

! Vernier 1/50mm on request.

mm	mm	mm	kg	Nº	Nº	Nº
200	80	1/20	0,45	1880 101	1880 201	1878 201
250	80	1/20	0,5	1880 102	1880 202	1878 202
300	90	1/20	0,55	1880 103	1880 203	1878 203

## Werkstatmessschieber ohne Spitzen

## Vernier calipers without points

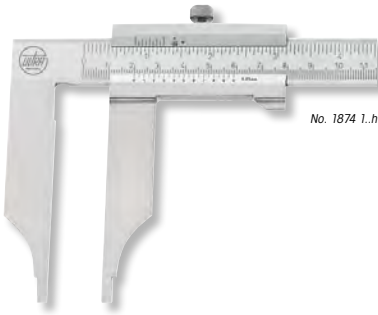

No. 1874 1..h

- ▶ DIN 862
- ▶ Feststellschraube
- ▶ rostfreier Stahl gehärtet
- ▶ Ablese Teile mattverchromt
- ▶ Lieferung inkl. Holzetui

- ▶ DIN 862
- ▶ Locking screw
- ▶ Hardened stainless steel
- ▶ Satin chrom reading parts
- ▶ Delivery incl. wooden box

**1874 1..h / 1893 1..h :**  
ohne Feineinstellung

**1874 1..h / 1893 1..h :**  
without fine adjustment

**1876 1..h / 1895 1..h :**  
mit Feineinstellung

**1876 1..h / 1895 1..h :**  
with fine adjustment

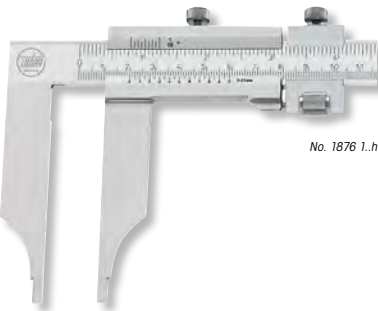

No. 1876 1..h

mm	inch	mm	mm	inch	kg	Nº	Nº
Lochmaßansatz Ø 10mm / Nibs for inside measurement Ø 10mm							
250	10	90	1/20	1/128	0,45	1874 102h	1876 102h
300	12	90	1/20	1/128	0,5	1874 103h	1876 103h
Lochmaßansatz Ø 20mm / Nibs for inside measurement Ø 20mm							
400		125	1/20		1,1	1893 101h	1895 101h
500		150	1/20		1,2	1893 103h	1895 103h
600		150	1/20		1,5	1893 105h	1895 105h
800		150	1/20		2,9	1893 107h	1895 107h
1000		150	1/20		3,9	1893 109h	1895 109h
Lochmaßansatz Ø 30mm / Nibs for inside measurement Ø 30mm							
1500		200	1/20		5,6	-	1895 111h
2000		200	1/20		9,6	-	1895 113h

## Werkstatmessschieber mit Spitzen

## Vernier calipers with points

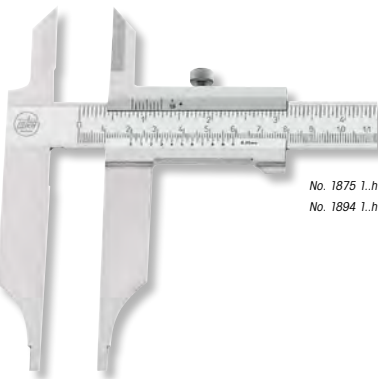

No. 1875 1..h

No. 1894 1..h

- ▶ DIN 862
- ▶ Feststellschraube
- ▶ rostfreier Stahl gehärtet
- ▶ Ablese Teile mattverchromt
- ▶ Lieferung inkl. Holzetui

- ▶ DIN 862
- ▶ Locking screw
- ▶ Hardened stainless steel
- ▶ Satin chrom reading parts
- ▶ Delivery incl. wooden box

**1875 1..h / 1894 1..h :**  
ohne Feineinstellung

**1875 1..h / 1894 1..h :**  
without fine adjustment

**1877 1..h / 1896 1..h :**  
mit Feineinstellung

**1877 1..h / 1896 1..h :**  
with fine adjustment

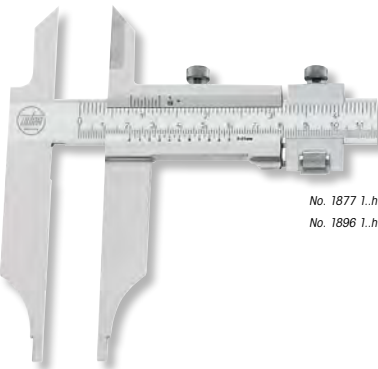

No. 1877 1..h

No. 1896 1..h

mm	inch	mm	mm	inch	kg	Nº	Nº
Lochmaßansatz Ø 10mm / Nibs for inside measurement Ø 10mm							
250	10	90	1/20	1/128	0,45	1875 102h	1877 102h
300	12	90	1/20	1/128	0,5	1875 103h	1877 103h
Lochmaßansatz Ø 20mm / Nibs for inside measurement Ø 20mm							
400		125	1/20		1,1	1894 101h	1896 101h
500		150	1/20		1,2	1894 103h	1896 103h
600		150	1/20		1,5	1894 105h	1896 105h
800		150	1/20		2,9	1894 107h	1896 107h
1000		150	1/20		3,9	1894 109h	1896 109h
Lochmaßansatz Ø 30mm / Nibs for inside measurement Ø 30mm							
1500		200	1/20		5,6	-	1896 111h
2000		200	1/20		9,6	-	1896 113h



## Werkstatmessschieber mit langen Schnäbeln, ohne Feineinstellung

## Vernier calipers with long jaws, without fine adjustment

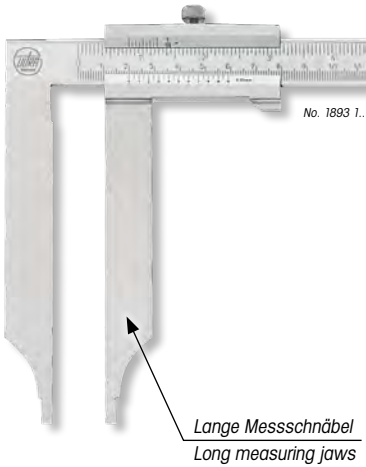

Lange Messschnäbel  
Long measuring jaws



Gehärtet  
Hardened

- ▶ Werksnorm
  - ▶ Feststellschraube
  - ▶ rostfreier Stahl gehärtet
  - ▶ Lieferung einzeln verpackt
- Bestellnummern die zusätzlich mit "h" gekennzeichnet sind = Lieferung inkl. Holzetui

- ▶ Works standard
  - ▶ Locking screw
  - ▶ Hardened stainless steel
  - ▶ Delivered in individual packages
- Order numbers which are additionally marked with "h" = Delivery incl. wooden box

**1889 1.. :**  
poliert, Nonius mattverchromt

**1889 1.. :**  
Polished, satin chromed vernier

**1893 1.. :**  
Nonius und Skala mattverchromt

**1893 1.. :**  
Satin chromed vernier and scale

**1897 1.. :**  
Holzetui

**1897 1.. :**  
Wooden box

! Nonius 1/50mm sowie andere Größen und größere Schnabellängen auf Anfrage.

! Vernier 1/50mm and other sizes and larger jaw lengths on request.

mm	mm	mm	kg	Nº	Nº	Nº
Lochmaßansatz Ø 20mm / Nibs for inside measurement Ø 20mm						
500	200	1/20	1,25	1889 104	1893 104	1897 104
500	250	1/20	1,45	1889 121	1893 121	1897 105
600	200	1/20	1,35	1889 106	1893 106	1897 107
600	300	1/20	1,5	1889 122	1893 122	1897 109
800	200	1/20	2,35	1889 108	1893 108	1897 110
800	300	1/20	2,45	1889 123	1893 123	1897 111
800	400	1/20	2,8	1889 123x	1893 123x	1897 112
1000	200	1/20	3,5	1889 110	1893 110	1897 113
1000	300	1/20	3,7	1889 124	1893 124	1897 114
1000	500	1/20	7,6	1889 124x	1893 124x	-
Lochmaßansatz Ø 30mm / Nibs for inside measurement Ø 30mm						
1500	300	1/20	5,95	1889 112	1893 112	1897 120
2000	300	1/20	9,9	1889 114	1893 114	1897 122
3000	300	1/20	19,9	1889 115	-	1897 126

## Messschieber für Außennuten

## Vernier calipers for outside grooves



No. 1928 103



Gehärtet  
Hardened

- ▶ Werksnorm
- ▶ Feststellschraube
- ▶ rostfreier Stahl gehärtet
- ▶ Ableseteile mattverchromt
- ▶ Lieferung einzeln verpackt

- ▶ Works standard
- ▶ Locking screw
- ▶ Hardened stainless steel
- ▶ Satin chrome reading parts
- ▶ Delivered in individual packages

**1928 1.. :**  
Messschieber

**1928 1.. :**  
Vernier calipers

**1929 1.. :**  
Holzetui

**1929 1.. :**  
Wooden box

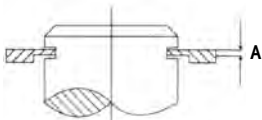

mm	inch	mm	A mm	mm	inch	kg	Nº	Nº
200	6	60	1,5	1/20	1/128	0,3	1928 101	1929 101
250	10	80	1,5	1/20	1/128	0,35	1928 102	1929 102
300	12	90	1,5	1/20	1/128	0,5	1928 103	1929 103

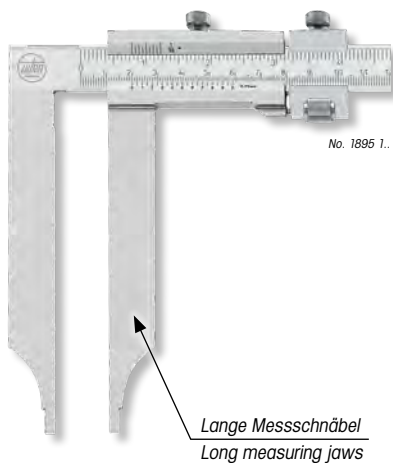

## Werkstatmessschieber mit langen Schnäbeln, mit Feineinstellung

## Vernier calipers with long jaws, with fine adjustment

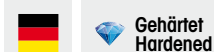

- ▶ Werksnorm
  - ▶ Feststellschraube
  - ▶ rostfreier Stahl gehärtet
  - ▶ Lieferung einzeln verpackt
- Bestellnummern die zusätzlich mit "h" gekennzeichnet sind = Lieferung inkl. Holzetui

- ▶ Works standard
  - ▶ Locking screw
  - ▶ Hardened stainless steel
  - ▶ Delivered in individual packages
- Order numbers which are additionally marked with "h" = Delivery incl. wooden box

**1891 1.. :**  
poliert, Nonius mattverchromt

**1891 1.. :**  
Polished, satin chromed vernier

**1895 1.. :**  
Nonius und Skala mattverchromt

**1895 1.. :**  
Satin chromed vernier and scale

**1897 1.. :**  
Holzetui

**1897 1.. :**  
Wooden box

**I** Nonius 1/50mm sowie andere Größen und größere Schnabellängen auf Anfrage.

**I** Vernier 1/50mm and other sizes and larger jaw lengths on request.

∩ mm	∩ mm	< mm	kg	Nº	Nº	Nº
Lochmaßansatz Ø 20mm / Nibs for inside measurement Ø 20mm						
500	200	1/20	1,25	1891 104	1895 104	1897 104
500	250	1/20	1,45	1891 121	1895 121	1897 105
600	200	1/20	1,35	1891 106	1895 106	1897 107
600	300	1/20	1,5	1891 122	1895 122	1897 109
800	200	1/20	2,35	1891 108	1895 108	1897 110
800	300	1/20	2,45	1891 123	1895 123	1897 111
800	400	1/20	2,8	1891 123x	1895 123x	1897 112
1000	200	1/20	3,5	1891 110	1895 110	1897 113
1000	300	1/20	3,7	1891 124	1895 124	1897 114
1000	500	1/20	7,6	1891 124x	1895 124x	-
Lochmaßansatz Ø 30mm / Nibs for inside measurement Ø 30mm						
1500	300	1/20	5,95	1891 112	1895 112	1897 120
2000	300	1/20	9,9	1891 114	1895 114	1897 122

## Werkstatmessschieber ALINOX

## Vernier calipers ALINOX

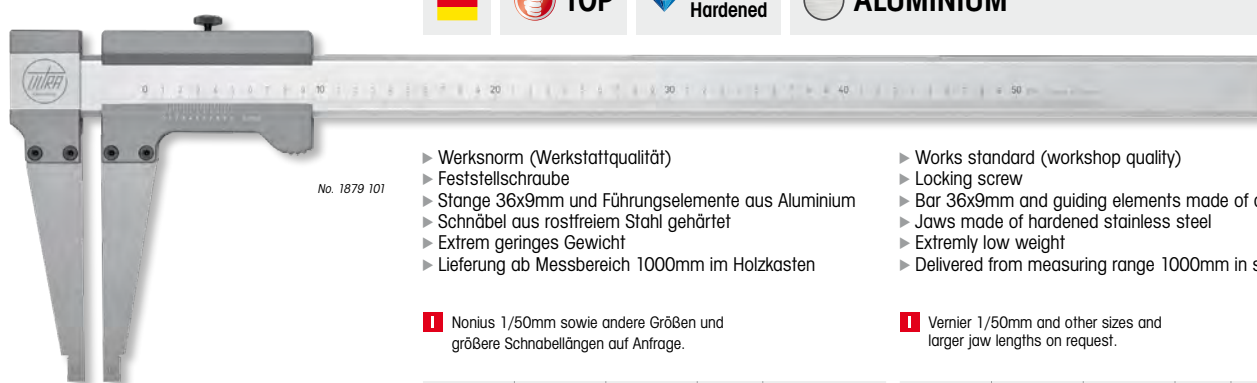

- ▶ Werksnorm (Werkstattqualität)
- ▶ Feststellschraube
- ▶ Stange 36x9mm und Führungselemente aus Aluminium
- ▶ Schnäbel aus rostfreiem Stahl gehärtet
- ▶ Extrem geringes Gewicht
- ▶ Lieferung ab Messbereich 1000mm im Holzkasten

- ▶ Works standard (workshop quality)
- ▶ Locking screw
- ▶ Bar 36x9mm and guiding elements made of aluminium
- ▶ Jaws made of hardened stainless steel
- ▶ Extremely low weight
- ▶ Delivered from measuring range 1000mm in storage box

**I** Nonius 1/50mm sowie andere Größen und größere Schnabellängen auf Anfrage.

**I** Vernier 1/50mm and other sizes and larger jaw lengths on request.

∩ mm	∩ mm	< mm	kg	Nº	∩ mm	∩ mm	< mm	kg	Nº
500	150	1/20	1,0	1879 101	2500	150	1/20	2,6	1879 113
500	300	1/20	1,3	1879 102	2500	300	1/20	2,9	1879 114
500	500	1/20	1,7	1879 103	2500	500	1/20	3,2	1879 115
1000	150	1/20	1,4	1879 104	3000	150	1/20	3,0	1879 116
1000	300	1/20	1,7	1879 105	3000	300	1/20	3,3	1879 117
1000	500	1/20	2,1	1879 106	3000	500	1/20	3,7	1879 118
1500	150	1/20	1,8	1879 107	4000	150	1/20	3,8	1879 119
1500	300	1/20	2,1	1879 108	4000	300	1/20	4,1	1879 120
1500	500	1/20	2,5	1879 109	4000	500	1/20	4,5	1879 121
2000	150	1/20	2,2	1879 110	Aufpreis für Feineinstellung Extra charge for fine adjustment				1879 199
2000	300	1/20	2,5	1879 111					
2000	500	1/20	2,9	1879 112					

**Messschieber MULTIPRE**  
Schnabel höhenverstellbar

**MULTIPRE offset vernier calipers**  
height adjustable jaw

  **Gehärtet Hardened**  **≤1000mm**



No. 1902 101  
No. 1904 201

- ▶ Werksnorm
  - ▶ Feststellschraube
  - ▶ rostfreier Stahl gehärtet
  - ▶ Ableseteile mattverchromt
  - ▶ mit Spitzen
  - ▶ Lochmaßansatz Ø 10mm
  - ▶ Lieferung in Kunststoffedertasche (ab 800mm im Holzetui)
- ▶ Works standard
  - ▶ Locking screw
  - ▶ Hardened stainless steel
  - ▶ Satin chrome reading parts
  - ▶ with points
  - ▶ Nibs for inside measurement Ø 10mm
  - ▶ Delivered in imitation leather bag (from 800mm in wooden case)



mm	inch	WF mm	mm	inch	kg	Nº
250	10	80	1/20	1/128	1,0	1902 101
500	20	150	1/20	1/128	2,0	1902 102
600	24	150	1/20	1/128	2,2	1902 103
800	32	150	1/20	1/128	2,3	1902 104
1000	40	150	1/20	1/128	2,8	1902 105

Messspitzen Paar für Nr. 1902 101 / Pair of measuring points for No. 1902 101 **1904 201**



Anreisspitze für Nr. 1902 101 / Scriber for No. 1902 101 **1904 202**

Messspitzen Paar für Nr. 1902 102 – 1902 105 / Pair of measuring points for No. 1902 102 – 1902 105 **1904 251**

Anreisspitze für Nr. 1902 102 – 1902 105 / Scriber for No. 1902 102 – 1902 105 **1904 252**

**Digital-Längenmaßstab CARBON**  
mit Lupe

**Digital length rule CARBON**  
with magnifier

  **TOP**   **Gehärtet Hardened**  **CARBON**

für Lupe Ø 31mm  
for magnifiers Ø 31mm

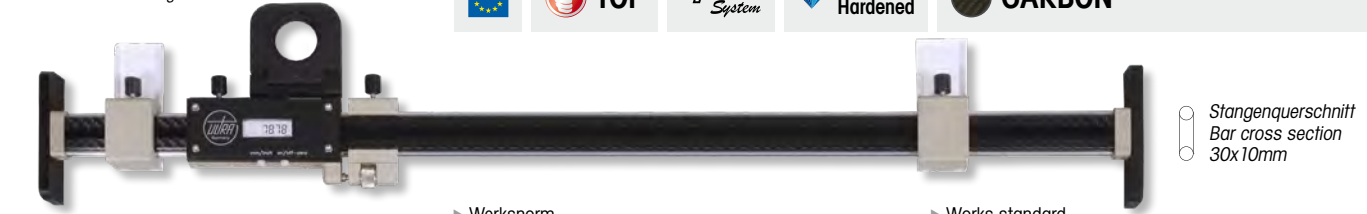

No. 1854 6.

- ▶ Werksnorm
  - ▶ Zum Messen von Abständen auf Flächen
  - ▶ Schutzart IP 54, Sylvac System
  - ▶ Feststellschraube
  - ▶ Stange aus Kohlefaser 30x10mm, Führungselemente aus verchromtem Stahl
  - ▶ Extrem geringes Gewicht, hohe Formstabilität
  - ▶ großes LCD Display
  - ▶ Lieferung im Holzetui mit Lupe
- ▶ Works standard
  - ▶ To measure a distance on a surface
  - ▶ Protection class IP 54, Sylvac System
  - ▶ Locking screw
  - ▶ Carbon fibre bar 30x10mm, guiding elements made of chromed steel
  - ▶ Extremely low weight, high strength of shape
  - ▶ Large LCD display
  - ▶ Delivered in wooden box incl. magnifier

Stangenquerschnitt  
Bar cross section  
30x10mm

- Funktionen:**
- ▶ Ein/Aus, mm/inch Umschaltung, ± Preset Funktion, O-Punkt an jeder Position, Hold Funktion, Datenausgang Opto
- Handhabung:**
- ▶ Anfangspunkt mit Lupe anvisieren und Anzeige nullen. Mit dem Schieber bis auf den Endpunkt fahren und genaue Position mit Lupe anvisieren. Exakte Länge auf der Digital-Anzeige ablesen.
- Funktionen:**
- ▶ On/Off, mm/inch commutation, ± preset function, Zero setting at any position, Hold function, Data output Opto
- Operation:**
- ▶ Focus on the initial point with the magnifier and reset the display. Slide the calliper to the end point and focus on the exact position with the magnifier. Read the exact length on the digital display.

Halter für Lupe umklappbar  
Holder for magnifier fold-away

**I** Größere Messbereiche auf Anfrage. **I** Larger measuring ranges on request.

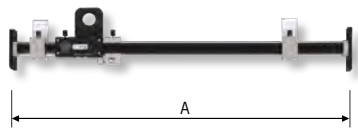

mm	inch	A mm	mm	inch	kg	Nº
450	18	720	0,01	.0005	1,0	1854 601
750	30	1020	0,01	.0005	1,9	1854 602
1150	45	1420	0,01	.0005	3,0	1854 603
1450	57	1720	0,01	.0005	3,7	1854 604

> 1450mm auf Anfrage / on request

Datenkabel RS232 (2m) / Data cable RS232 (2m) **1850 203**

Datenkabel USB (2m) / Data cable USB (2m) **1850 204**

**Digital-Anbaumessschieber**  
horizontal oder verikal

**Digital mounting rules**  
horizontal or vertical



No. 1854 7..

- ▶ Werksnorm
- ▶ Sylvac System
- ▶ mit kugelgelagerter Führung
- ▶ rostfreier Stahl gehärtet
- ▶ Stangenquerschnitt 20x10,4mm
- ▶ großes LCD Display
- ▶ Lieferung einzeln verpackt

- ▶ Works standard
- ▶ Sylvac System
- ▶ With ball bearing guide
- ▶ Hardened stainless steel
- ▶ Bar cross section 20x10.4mm
- ▶ Large LCD display
- ▶ Delivered in individual packages

**Funktionen:**

- ▶ Ein/Aus, mm/inch Umschaltung, O-Punkt an jeder Position, ± Preset Funktion, Hold Funktion, Datenausgang Opto

**Functions:**

- ▶ On/Off, mm/inch commutation, Zero setting at any position, ± Preset function, Hold function, Data output Opto



No. 1854 8..

**1854 7.. :**  
Horizontal-Modell

**1854 7.. :**  
Horizontal model

**1854 8.. :**  
Vertikal-Modell

**1854 8.. :**  
Vertical model

! Größere Messbereiche auf Anfrage.

! Larger measuring ranges on request.

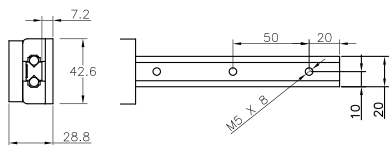

mm	μm	inch	mm	μm	inch	kg	Nº	Nº
200		8	0,01		.0005	0,35	1854 701	1854 801
300		12	0,01		.0005	0,45	1854 702	1854 802
500		20	0,01		.0005	0,6	1854 703	1854 803

> 500mm auf Anfrage / on request

**Digital-Anbaumessschieber**  
horizontal oder verikal

**Digital mounting rules**  
horizontal or vertical



No. 1854 301

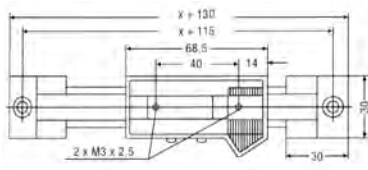

- ▶ Werksnorm
- ▶ Sylvac System
- ▶ mit 2 Befestigungsbohrungen
- ▶ rostfreier Stahl gehärtet
- ▶ Stangenquerschnitt 20x5mm
- ▶ großes LCD Display
- ▶ Lieferung einzeln verpackt

- ▶ Works standard
- ▶ Sylvac System
- ▶ With 2 fixture holes
- ▶ Hardened stainless steel
- ▶ Bar cross section 20x5mm
- ▶ Large LCD display
- ▶ Delivered in individual packages

**Funktionen:**

- ▶ Ein/Aus, mm/inch Umschaltung, O-Punkt an jeder Position, ± Preset Funktion, Hold Funktion, Datenausgang Opto

**Functions:**

- ▶ On/Off, mm/inch commutation, Zero setting at any position, ± Preset function, Hold function, Data output Opto

**1854 3.. :**  
Horizontal-Modell

**1854 3.. :**  
Horizontal model

**1854 4.. :**  
Vertikal-Modell

**1854 4.. :**  
Vertical model

! Größere Messbereiche auf Anfrage.

! Larger measuring ranges on request.



No. 1854 401

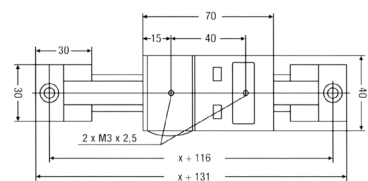

mm	μm	inch	mm	μm	inch	kg	Nº	Nº
150		6	0,01		.0005	0,15	1854 300	1854 400
200		8	0,01		.0005	0,3	1854 301	1854 401
300		12	0,01		.0005	0,4	1854 302	1854 402
450		18	0,01		.0005	0,7	1854 303	1854 403
600		24	0,01		.0005	0,95	1854 304	1854 404
800		31	0,01		.0005	1,25	1854 305	1854 405
1000		39	0,01		.0005	1,55	1854 306	1854 406

> 1000mm auf Anfrage / on request

## Digital-Tiefenmessschieber CARBON mit umsteckbarem Stahlstift 90°

## Digital-depth calipers CARBON with turnable steel pin 90°



No. 1852 60.

- ▶ Werksnorm
- ▶ Schutzart IP 54, Sylvac System
- ▶ Feststellschraube und Feineinstellung
- ▶ Stange aus Kohlefaser 30x10mm, Führungselemente aus verchromtem Stahl
- ▶ Messflächen aus rostfreiem Stahl, gehärtet
- ▶ Extrem geringes Gewicht, hohe Formstabilität
- ▶ großes LCD Display
- ▶ Lieferung im Holzetui

- ▶ Works standard
- ▶ Protection class IP 54, Sylvac System
- ▶ Locking screw and fine adjustment
- ▶ Carbon fibre bar 30x10mm, guiding elements made of chromed steel
- ▶ Measuring faces made of stainless steel, hardened
- ▶ Extremely low weight, high strength of shape
- ▶ Large LCD display
- ▶ Delivered in wooden case

### Funktionen:

- ▶ Ein/Aus, mm/inch Umschaltung, 0-Punkt an jeder Position, Hold Funktion, Datenausgang Opto

### Functions:

- ▶ On/Off, mm/inch commutation, Zero setting at any position, Hold function, Data output Opto

1 Andere Größen und Brückenlängen auf Anfrage.

1 Other sizes and bridge lengths on request.

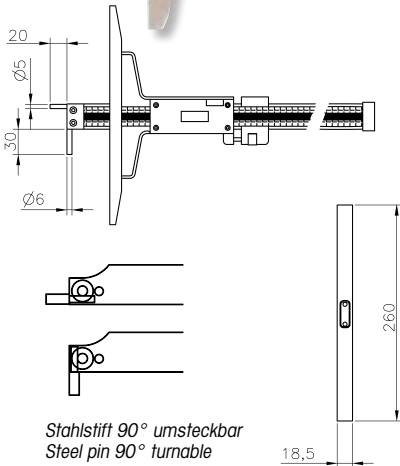

Stahlstift 90° umsteckbar  
Steel pin 90° turnable

mm	inch	mm	mm	inch	mm	Nº
600	24	260	0,01	.0005	1,34	1852 601
800	32	260	0,01	.0005	1,47	1852 602
1000	40	260	0,01	.0005	1,6	1852 603
1200	48	260	0,01	.0005	1,73	1852 604

> 1200mm auf Anfrage / on request

Datenkabel RS232 (2m) / Data cable RS232 (2m)

1850 203

Datenkabel USB (2m) / Data cable USB (2m)

1850 204

## Digital-Tiefenmessschieber CARBON mit Winkelhaken

## Digital-Depth calipers CARBON with hook



No. 1852 80.

- ▶ Werksnorm
- ▶ Schutzart IP 54, Sylvac System
- ▶ Feststellschraube und Feineinstellung
- ▶ Stange aus Kohlefaser 30x10mm, Führungselemente aus verchromtem Stahl
- ▶ Messflächen aus rostfreiem Stahl, gehärtet
- ▶ Extrem geringes Gewicht, hohe Formstabilität
- ▶ großes LCD Display
- ▶ Lieferung im Holzetui

- ▶ Works standard
- ▶ Protection class IP 54, Sylvac System
- ▶ Locking screw and fine adjustment
- ▶ Carbon fibre bar 30x10mm, guiding elements made of chromed steel
- ▶ Measuring faces made of stainless steel, hardened
- ▶ Extremely low weight, high strength of shape
- ▶ Large LCD display
- ▶ Delivered in wooden box

### Funktionen:

- ▶ Ein/Aus, mm/inch Umschaltung, 0-Punkt an jeder Position, Hold Funktion, Datenausgang Opto

### Functions:

- ▶ On/Off, mm/inch commutation, Zero setting at any position, Hold function, Data output Opto

1 Andere Größen und Brückenlängen auf Anfrage.

1 Other sizes and bridge length on request.

mm	inch	mm	mm	inch	kg	Nº
1000	40	350	0,01	.0005	2,5	1852 801
1500	60	350	0,01	.0005	2,7	1852 802
2000	80	350	0,01	.0005	3,1	1852 803

> 2000mm auf Anfrage / on request

Messbrücke 400mm (Paar) / Measuring bridge 400mm (pair)

0,57

1852 851

Messbrücke 500mm (Paar) / Measuring bridge 500mm (pair)

0,69

1852 852

Messbrücke 600mm (Paar) / Measuring bridge 600mm (pair)

0,83

1852 853

Datenkabel RS232 (2m) / Data cable RS232 (2m)

1850 203

Datenkabel USB (2m) / Data cable USB (2m)

1850 204

## Digital-Tiefenmessschieber, IP67 für kleine Bohrungen

## Digital depth calipers, IP67 for small holes



No. 1852 501



No. 1850 203

- ▶ Werknorm
- ▶ Schutzart IP 67, Sylvac System
- ▶ Feststellschraube
- ▶ rostfreier Stahl gehärtet
- ▶ großes LCD Display
- ▶ Lieferung im Etui

### Funktionen:

- ▶ Ein/Aus
- ▶ mm/inch Umschaltung
- ▶ 0-Punkt an jeder Position
- ▶ ± Preset Funktion
- ▶ Hold Funktion
- ▶ Datenausgang Proximity

- ▶ Works standard
- ▶ Protection class IP 67, Sylvac System
- ▶ Locking screw
- ▶ Hardened stainless steel
- ▶ Large LCD display
- ▶ Delivered in case

### Funktionen:

- ▶ On/Off
- ▶ mm/inch commutation
- ▶ Zero setting at any position
- ▶ ± Preset function
- ▶ Hold function
- ▶ Data output Proximity

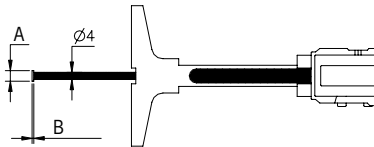

mm	inch	mm	A Ø mm	B mm	mm	inch	kg	Nº
120	4,8	80	7,8	0,9	0,01	.0005	0,27	1852 501
120	4,8	80	5,8	0,6	0,01	.0005	0,27	1852 502

Datenkabel RS232 (2m) / Data cable RS232 (2m)

Datenkabel USB (2m) / Data cable USB (2m)

1850 203ip

1850 204ip



No. 1852 7.

## Digital-Tiefenmessschieber ALINOX Stahlstift gehärtet

## Digital-Depth calipers ALINOX steel pin hardened



- ▶ Werknorm (Werkstattqualität)
- ▶ Schutzart IP 54, Sylvac System
- ▶ Feststellschraube
- ▶ Stange 36x9mm und Führungselemente aus Aluminium
- ▶ Messbrücke aus rostfreiem Stahl gehärtet
- ▶ Extrem geringes Gewicht
- ▶ großes LCD Display
- ▶ Lieferung ab Messbereich 1000mm im Holzkasten

### Funktionen:

- ▶ Ein/Aus, mm/inch Umschaltung, 0-Punkt an jeder Position, Hold Funktion, Datenausgang Opto

- ▶ Works standard (workshop quality)
- ▶ Protection class IP 54, Sylvac System
- ▶ Locking screw
- ▶ Bar 36x9mm and guiding elements made of aluminium
- ▶ Measuring bridge made of hardened stainless steel
- ▶ Extremely low weight
- ▶ Large LCD display
- ▶ Delivered from measuring range 1000mm in storage box

### Funktionen:

- ▶ On/Off, mm/inch commutation, Zero setting at any position, Hold function, Data output Opto

! Andere Größen und andere Messbrückenlängen auf Anfrage.

! Other sizes and other measuring bridge lengths on request.

mm	inch	mm	mm	inch	kg	Nº
500	20	200	0,01	.0005	1,1	1852 701
500	20	300	0,01	.0005	1,3	1852 702
500	20	500	0,01	.0005	1,7	1852 703
1000	40	200	0,01	.0005	1,5	1852 704
1000	40	300	0,01	.0005	1,7	1852 705
1000	40	500	0,01	.0005	2,1	1852 706
1500	60	200	0,01	.0005	1,9	1852 707
1500	60	300	0,01	.0005	2,1	1852 708
1500	60	500	0,01	.0005	2,5	1852 709
2000	80	200	0,01	.0005	2,3	1852 710
2000	80	300	0,01	.0005	2,6	1852 711
2000	80	500	0,01	.0005	2,9	1852 712

Aufpreis für Feineinstellung / Extra charge for fine adjustment

Datenkabel RS232 (2m) / Data cable RS232 (2m)

Datenkabel USB (2m) / Data cable USB (2m)

1879 199

1850 203

1850 204

**Tiefenmessschieber ALINOX  
Stahlstift gehärtet**

**Vernier depth calipers ALINOX  
steel pin hardened**

 **TOP**
 **Gehärtet  
Hardened**
 **ALUMINIUM**



No. 1943 1..

- ▶ Werksnorm (Werkstattqualität)
- ▶ Feststellschraube
- ▶ Stange 36x9mm und Führungselemente aus Aluminium
- ▶ Messbrücke aus rostfreiem Stahl gehärtet
- ▶ Extrem geringes Gewicht
- ▶ Lieferung ab Messbereich 1000mm im Holzkasten

- ▶ Works standard (workshop quality)
- ▶ Locking screw
- ▶ Bar 36x9mm and guiding elements made of aluminium
- ▶ Measuring bridge made of hardened stainless steel
- ▶ Extremely low weight
- ▶ Delivered from measuring range 1000mm in storage box





**1** Nonius 1/50mm sowie andere Größen und andere Messbrückenlängen auf Anfrage.

**1** Vernier 1/50mm, other sizes and other measuring bridge lengths on request.

mm	mm	<math>\leq</math> mm	kg	Nº	mm	mm	<math>\leq</math> mm	kg	Nº
500	200	1/20	1,1	1943 101	2500	200	1/20	2,7	1943 113
500	300	1/20	1,3	1943 102	2500	300	1/20	2,9	1943 114
500	500	1/20	1,7	1943 103	2500	500	1/20	3,3	1943 115
1000	200	1/20	1,5	1943 104	3000	200	1/20	3,1	1943 116
1000	300	1/20	1,7	1943 105	3000	300	1/20	3,3	1943 117
1000	500	1/20	2,1	1943 106	3000	500	1/20	3,7	1943 118
1500	200	1/20	1,9	1943 107	4000	200	1/20	3,9	1943 119
1500	300	1/20	2,1	1943 108	4000	300	1/20	4,1	1943 120
1500	500	1/20	2,5	1943 109	4000	500	1/20	4,5	1943 121
2000	200	1/20	2,3	1943 110	Aufpreis für Feineinstellung Extra charge for fine adjustment				1879 199
2000	300	1/20	2,6	1943 111					
2000	500	1/20	2,9	1943 112					

**Digital-Tiefenmessschieber, IP67  
mit abgeschrägter Spitze**

**Digital depth caliper, IP67  
with bevelled point**

 **TOP**
 **IP67**

 **Gehärtet  
Hardened**



No. 1852 098ip

- ▶ Werksnorm
- ▶ Schutzart IP 67, Sylvac System
- ▶ Feststellschraube
- ▶ rostfreier Stahl gehärtet
- ▶ großes LCD Display
- ▶ extra lange Messbrücke optional
- ▶ Lieferung im Etui

- ▶ Works standard
- ▶ Protection class IP 67, Sylvac System
- ▶ Locking screw
- ▶ Hardened stainless steel
- ▶ Large LCD display
- ▶ Extra long bridge optional
- ▶ Delivered in case

**Funktionen:**

- ▶ Ein/Aus, Auto-On bei Bewegung, mm/inch Umschaltung, 0-Punkt an jeder Position, Lock Funktion (fester 0-Punkt), absolutes System, Datenausgang Proximity

**Functions:**

- ▶ On/Off, Auto-On by sliding, mm/inch commutation, Zero setting at any position, Lock function (fixed 0 point), absolute system, Data output Proximity

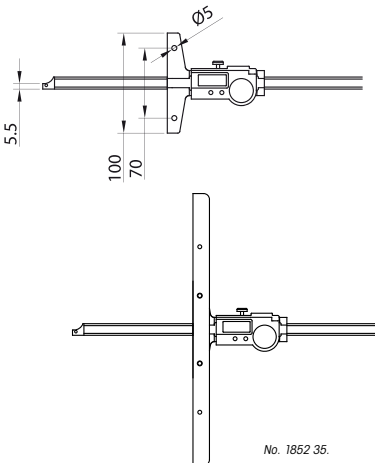

mm	mm	inch	mm	mm	<math>\leq</math> mm	inch	kg	Nº
150		6	100	0,01	.0005		0,26	1852 098ip
200		8	100	0,01	.0005		0,3	1852 099ip
250		10	100	0,01	.0005		0,32	1852 100ip
300		12	100	0,01	.0005		0,33	1852 101ip
400		16	100	0,01	.0005		0,35	1852 102ip
500		20	100	0,01	.0005		0,39	1852 103ip
600		24	100	0,01	.0005		0,43	1852 104ip
Messbrücke 200mm / Measuring bridge 200mm							0,23	1852 351
Messbrücke 320mm / Measuring bridge 320mm							0,35	1852 352
Datenkabel RS232 (2m) / Data cable RS232 (2m)								1850 203ip
Datenkabel USB (2m) / Data cable USB (2m)								1850 204ip



No. 1853 40.

Mit großer 3V Batterie.  
With large 3V battery.

Stahlstift 90° umsteckbar  
Steel pin 90° turnable

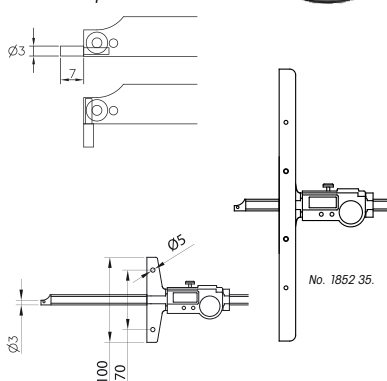

**Digital Tiefenmessschieber, IP67 mit umsteckbarem Stahlstift 90°**

**Digital depth calipers, IP 67 with turnable steel pin 90°**

- ▶ Werksnorm
- ▶ Schutzart IP 67, Sylvac System
- ▶ Feststellschraube
- ▶ rostfreier Stahl gehärtet
- ▶ großes LCD Display
- ▶ Tiefenmessbrücke mit Bohrung Ø 5mm und Bohrungsabstand 70mm für optionale Messbrücke
- ▶ Lieferung im Etui

**Funktionen:**  
 ▶ Ein/Aus, Auto-On bei Bewegung, mm/inch Umschaltung, O-Punkt an jeder Position, Lock Funktion (fester O-Punkt), absolutes System, Datenausgang Proximity

- ▶ Works standard
- ▶ Protection class IP 67, Sylvac System
- ▶ Locking screw
- ▶ Hardened stainless steel
- ▶ Large LCD display
- ▶ Measuring bridge with bore Ø 5mm and bore distance 70mm for optional measuring bridge
- ▶ Delivered in wooden case

**Functions:**  
 ▶ On/Off, Auto-On by sliding, mm/inch commutation, Zero setting at any position, Lock function (fixed O point), absolute system, Data output Proximity

mm	inch	mm	mm	inch	kg	Nº
150	6	100	0,01	.0005	0,26	1853 401
200	8	100	0,01	.0005	0,3	1853 402
250	10	100	0,01	.0005	0,32	1853 403
300	12	100	0,01	.0005	0,33	1853 404
400	16	100	0,01	.0005	0,35	1853 405
500	20	100	0,01	.0005	0,39	1853 406
600	24	100	0,01	.0005	0,43	1853 407
Messbrücke 200mm / Measuring bridge 200mm					0,23	1852 351
Messbrücke 320mm / Measuring bridge 320mm					0,35	1852 352
Datenkabel RS232 (2m) / Data cable RS232 (2m)						1850 203ip
Datenkabel USB (2m) / Data cable USB (2m)						1850 204ip

**Digital-Tiefenmessschieber, IP67 mit auswechselbarem Messeinsatz**

**Digital depth calipers, IP67 with interchangeable insert**



No. 1853 206

Messeinsätze auswechselbar  
Inserts interchangeable

Stangenquerschnitt  
Bar cross section  
12x4mm

- ▶ Werksnorm
- ▶ Schutzart IP 67, Sylvac System
- ▶ Feststellschraube
- ▶ rostfreier Stahl gehärtet
- ▶ großes LCD Display
- ▶ Lieferung im Holzetui mit Messeinsatz

**Funktionen:**  
 ▶ Ein/Aus  
 ▶ mm/inch Umschaltung  
 ▶ O-Punkt an jeder Position  
 ▶ ± Preset Funktion  
 ▶ Hold Funktion  
 ▶ Datenausgang Proximity

- ▶ Works standard
- ▶ Protection class IP 67, Sylvac System
- ▶ Locking screw
- ▶ Hardened stainless steel
- ▶ Large LCD display
- ▶ Delivered in wooden case including insert

**Functions:**  
 ▶ On/Off  
 ▶ mm/inch commutation  
 ▶ Zero setting at any position  
 ▶ ± Preset function  
 ▶ Hold function  
 ▶ Data output Proximity

mm	inch	mm	mm	inch	kg	Nº
50	6	100	0,01	.0005	0,26	1853 201
100	8	100	0,01	.0005	0,3	1853 202
300	12	150	0,01	.0005	0,43	1853 203
400	16	150	0,01	.0005	0,46	1853 204
500	20	150	0,01	.0005	0,5	1853 205
600	24	150	0,01	.0005	0,53	1853 206
Messbrücke 200mm / Measuring bridge 200mm					0,23	1852 351
Messbrücke 320mm / Measuring bridge 320mm					0,35	1852 352
Datenkabel RS232 (2m) / Data cable RS232 (2m)						1850 203ip
Datenkabel USB (2m) / Data cable USB (2m)						1850 204ip



**Digital-Tiefenmessschieber, IP67  
mit auswechselbarem Messeinsatz**

**Digital depth calipers, IP67  
with interchangeable insert**



TOP



IP67



Gehärtet  
Hardened

Stangenquerschnitt  
Bar cross section  
12x4mm



Messeinsätze auswechselbar  
Inserts interchangeable

No. 1853 301

- ▶ Werknorm
- ▶ Schutzart IP 67, Sylvac System
- ▶ Feststellschraube
- ▶ rostfreier Stahl gehärtet
- ▶ großes LCD Display
- ▶ verschiebbare Messbrücke optional
- ▶ Lieferung im Holzetui mit Messeinsatz Nr. 1853 901

- ▶ Works standard
- ▶ Protection class IP 67, Sylvac System
- ▶ Locking screw
- ▶ Hardened stainless steel
- ▶ Large LCD display
- ▶ Moveable bridge optional
- ▶ Delivered in wooden case including insert No. 1853 901

**Funktionen:**

- ▶ Ein/Aus
- ▶ Auto-On Bewegung
- ▶ mm/inch Umschaltung
- ▶ 0-Punkt an jeder Position
- ▶ Lock Funktion (fester 0-Punkt), absolutes System
- ▶ Datenausgang Proximity

**Functions:**

- ▶ On/Off
- ▶ Auto-On by sliding
- ▶ mm/inch commutation
- ▶ Zero setting at any position
- ▶ Lock function (fixed 0 point), absolute system
- ▶ Data output Proximity



Anwendung mit verschiebbarer Messbrücke  
Application with moveable measuring bridge

No. 1853 351 Messbrücke / Measuring bridge

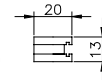

mm	inch	mm	mm	inch	kg	Nº
300	12	150	0,01	.0005	0,43	1853 301
400	16	150	0,01	.0005	0,47	1853 302
500	20	150	0,01	.0005	0,5	1853 303
600	24	150	0,01	.0005	0,53	1853 304
800	32	150	0,01	.0005	0,58	1853 305
1000	40	150	0,01	.0005	0,63	1853 306
					0,57	1853 351
Messbrücke 400mm / Measuring bridge 400mm					0,69	1853 352
Messbrücke 500mm / Measuring bridge 500mm					0,83	1853 353
Messbrücke 600mm / Measuring bridge 600mm						1850 203ip
Datenkabel RS232 (2m) / Data cable RS232 (2m)						1850 204ip
Datenkabel USB (2m) / Data cable USB (2m)						

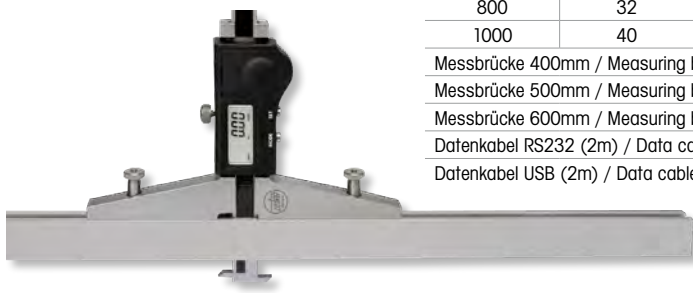

**Messeinsätze für Digital-Tiefenmessschieber**

**Inserts for digital depth calipers**



Gehärtet  
Hardened

- ▶ aus gehärtetem Spezialstahl
- ▶ Lieferung einzeln verpackt

- ▶ Hardened special steel
- ▶ Delivered in individual packages

! Andere Messtaster auf Anfrage.

! Other measurings inserts on request.

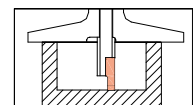
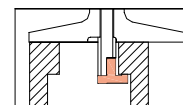
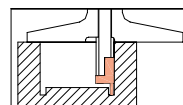
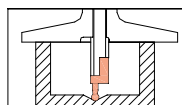
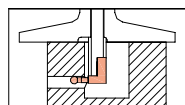
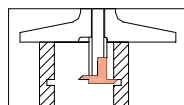
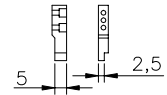
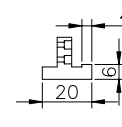
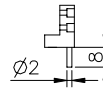
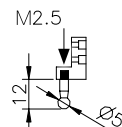
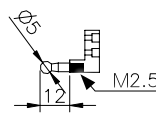
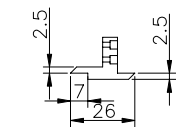

Nº	1853 901	1853 902	1853 903	1853 904	1853 905	1853 906
----	----------	----------	----------	----------	----------	----------





### Digital-Tiefenmessschieber STANDARD

### Digital depth calipers STANDARD



**Gehärtet  
Hardened**

No. 1852 099s

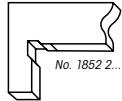
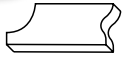

No. 1852 2...

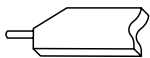

No. 1852 4...

- ▶ DIN 862
- ▶ Festsstellschraube
- ▶ rostfreier Stahl gehärtet
- ▶ großes LCD Display
- ▶ Lieferung im Etui

**Funktionen:**

- ▶ Ein/Aus
- ▶ mm/inch Umschaltung
- ▶ O-Punkt an jeder Position

- ▶ DIN 862
- ▶ Locking screw
- ▶ Hardened stainless steel
- ▶ Large LCD display
- ▶ Delivered in a case

**Functions:**

- ▶ On/Off
- ▶ mm/inch commutation
- ▶ Zero setting at any position

mm	inch	mm	mm	inch	kg	Nº
abgeschrägte Spitze / Bevelled point						
150	6	100	0,01	.0005	0,4	1852 098s
200	8	100	0,01	.0005	0,5	1852 099s
300	12	150	0,01	.0005	0,6	1852 101s
500	20	150	0,01	.0005	0,7	1852 102s
Winkelhaken / Hook						
300	12	150	0,01	.0005	0,6	1852 201s
500	20	150	0,01	.0005	0,7	1852 202s
Stahlstift gehärtet / Steel pin hardened						
150	6	100	0,01	.0005	0,4	1852 398s
200	8	100	0,01	.0005	0,5	1852 399s
300	12	150	0,01	.0005	0,6	1852 401s



### Tiefenmessschieber, abgeschrägte Spitze

### Vernier depth calipers, bevelled point



**Gehärtet  
Hardened**

No. 1939 101



- ▶ DIN 862
- ▶ Festsstellschraube
- ▶ rostfreier Stahl gehärtet
- ▶ Ableseteile mattverchromt
- ▶ Lieferung einzeln verpackt

- ▶ DIN 862
- ▶ Locking screw
- ▶ Hardened stainless steel
- ▶ Satin chrome reading parts
- ▶ Delivered in individual packages

**1942 1..:**

Holzetui

**1942 1..:**

Wooden box

**1** Andere Ausführungen auf Anfrage.

**1** Other versions on request.

mm	mm	mm	kg	Nº	Nº
150	100	1/20	0,1	1939 101	1942 101
200	100	1/20	0,13	1939 102	1942 102
300	150	1/20	0,29	1939 104	1942 104
500	150	1/20	0,33	1939 106	1942 106
800	250	1/20	1,2	1939 108	1942 108
1000	250	1/20	1,35	1939 109	1942 109

## Tiefenmessschieber, Stahlstift gehärtet

## Vernier depth calipers, steel pin hardened



**Gehärtet  
Hardened**



- ▶ DIN 862
- ▶ Feststellschraube
- ▶ rostfreier Stahl gehärtet
- ▶ Ablese Teile mattverchromt
- ▶ Lieferung einzeln verpackt

- ▶ DIN 862
- ▶ Locking screw
- ▶ Hardened stainless steel
- ▶ Satin chrome reading parts
- ▶ Delivered in individual packages

### 1942 1..:

Holzetui

### 1942 1..:

Wooden box

**I** Andere Ausführungen auf Anfrage.

**I** Other versions on request.

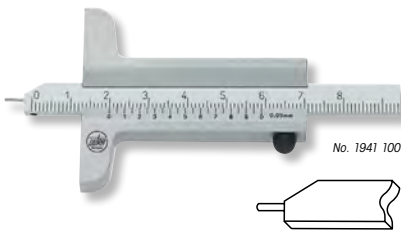

mm	mm	mm	kg	Nº	Nº
80	50	1/20	0,11	1941 100	1942 100
150	100	1/20	0,1	1941 101	1942 101
200	100	1/20	0,13	1941 102	1942 102
300	150	1/20	0,3	1941 104	1942 104

## Tiefenmessschieber mit verschiebbarer Messbrücke

## Depth calipers with movable bridge



**Gehärtet  
Hardened**

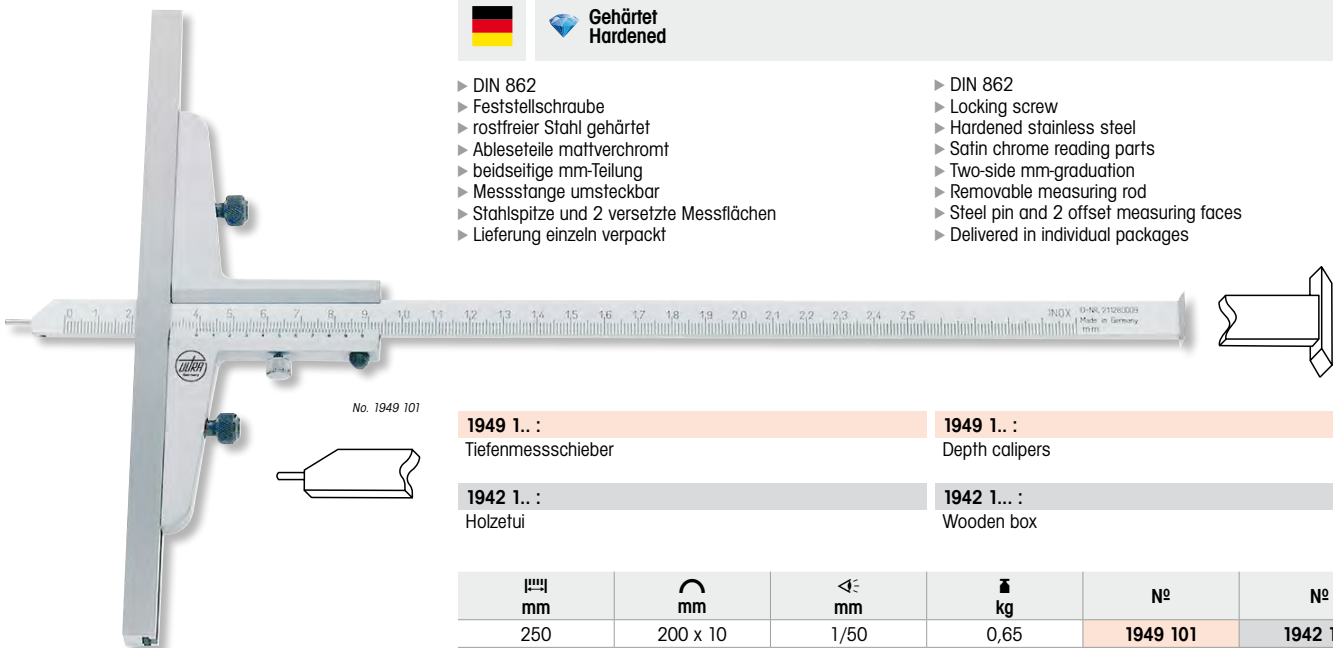

- ▶ DIN 862
- ▶ Feststellschraube
- ▶ rostfreier Stahl gehärtet
- ▶ Ablese Teile mattverchromt
- ▶ beidseitige mm-Teilung
- ▶ Messstange umsteckbar
- ▶ Stahlspitze und 2 versetzte Messflächen
- ▶ Lieferung einzeln verpackt

- ▶ DIN 862
- ▶ Locking screw
- ▶ Hardened stainless steel
- ▶ Satin chrome reading parts
- ▶ Two-side mm-graduation
- ▶ Removable measuring rod
- ▶ Steel pin and 2 offset measuring faces
- ▶ Delivered in individual packages

### 1949 1.. :

Tiefenmessschieber

### 1949 1.. :

Depth calipers

### 1942 1.. :

Holzetui

### 1942 1.. :

Wooden box

mm	mm	mm	kg	Nº	Nº
250	200 x 10	1/50	0,65	1949 101	1942 103
500	400 x 16	1/50	1,6	1949 102	1942 106
750	400 x 20	1/50	4,1	1949 103	1942 108
1000	600 x 20	1/50	5,6	1949 104	1942 109

**Tiefenmessschieber mit Winkelhaken und abgeschrägter Spitze**

**Vernier depth calipers with hook and bevelled point**



- ▶ DIN 862
- ▶ Feststellschraube
- ▶ rostfreier Stahl gehärtet
- ▶ Ableseteile mattverchromt
- ▶ beidseitige mm-Teilung
- ▶ Messstange umsteckbar
- ▶ Lieferung einzeln verpackt

- ▶ DIN 862
- ▶ Locking screw
- ▶ Hardened stainless steel
- ▶ Satin chrome reading parts
- ▶ Two-side mm-graduation
- ▶ Removable measuring rod
- ▶ Delivered in individual packages

**1942 1..:**  
Holzetui

**1942 1..:**  
Wooden box

! Andere Ausführungen auf Anfrage.

! Other versions on request.

mm	mm	<math>\leq</math> mm	kg	Nº	Nº
150	100	1/20	0,1	1940 101	1942 101
200	100	1/20	0,13	1940 102	1942 102
300	150	1/20	0,3	1940 104	1942 104
500	150	1/20	0,35	1940 106	1942 106

**Tiefenmessschieber mit 2 versetzten Messflächen und abgeschrägter Spitze**

**Vernier depth calipers with 2 offset measuring faces and bevelled point**

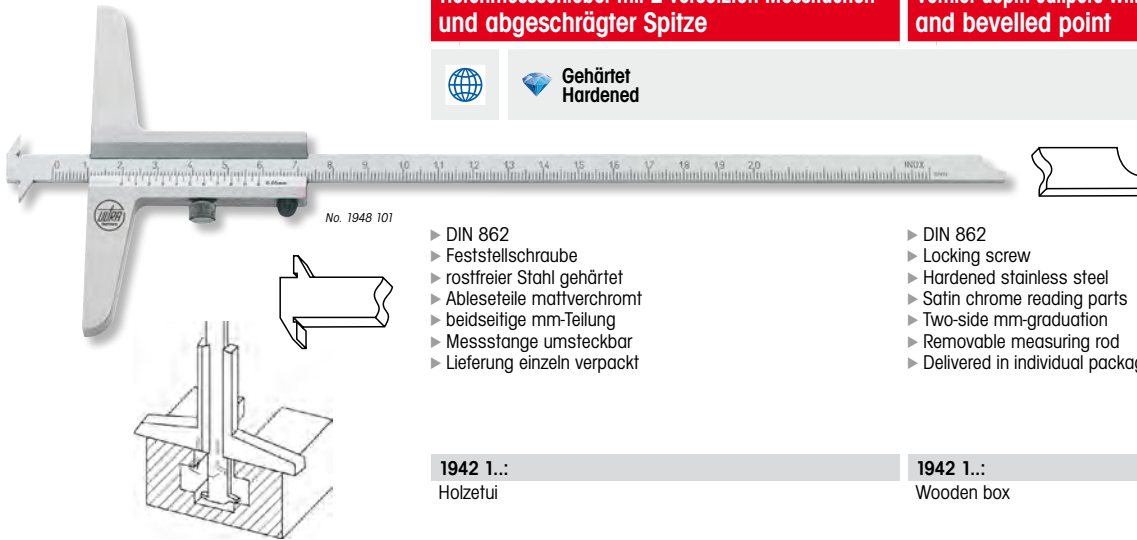

- ▶ DIN 862
- ▶ Feststellschraube
- ▶ rostfreier Stahl gehärtet
- ▶ Ableseteile mattverchromt
- ▶ beidseitige mm-Teilung
- ▶ Messstange umsteckbar
- ▶ Lieferung einzeln verpackt

- ▶ DIN 862
- ▶ Locking screw
- ▶ Hardened stainless steel
- ▶ Satin chrome reading parts
- ▶ Two-side mm-graduation
- ▶ Removable measuring rod
- ▶ Delivered in individual packages

**1942 1..:**  
Holzetui

**1942 1..:**  
Wooden box

! Andere Ausführungen auf Anfrage.

! Other versions on request.

mm	mm	<math>\leq</math> mm	kg	Nº	Nº
200	100	1/20	0,13	1948 101	1942 102
300	100	1/20	0,18	1948 102	1942 104

**Datenübertragungskabel für Opto-Schnittstelle**

**Data cable for Opto-Data output**

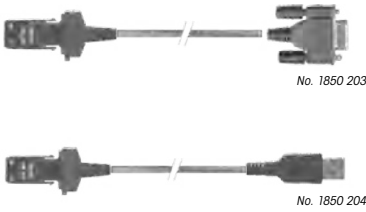

- ▶ Länge 2m
- ▶ Lieferung einzeln verpackt, inkl. Software für Datenimport in MS Excel etc.

- ▶ Length 2m
- ▶ Delivered in individual packages incl. software for data import in MS Excel etc.

Typ Type	Nº
Datenkabel Opto/RS232 SIMPLEX (2m) / Data cable Opto/RS232 SIMPLEX (2m)	<b>1850 203</b>
Datenkabel Opto/USB SIMPLEX (2m) / Data cable Opto/USB SIMPLEX (2m)	<b>1850 204</b>
Datenkabel Opto/RS 232 DUPLEX (2m) / Data cable Opto/RS 232 DUPLEX (2m)	<b>1850 205</b>

**Datenübertragungskabel für Proximity-Schnittstelle**

**Data cable for Proximity-Data output**

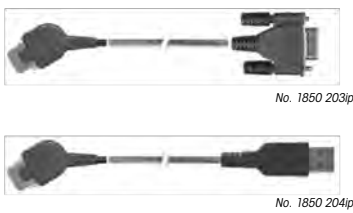

- ▶ Länge 3m
- ▶ Lieferung einzeln verpackt, inkl. Software für Datenimport in MS Excel etc.

- ▶ Length 3m
- ▶ Delivered in individual packages incl. software for data import in MS Excel etc.

Typ Type	Nº
Datenkabel Proximity/RS 232 (2m) / Data cable Proximity/RS 232 (2m)	<b>1850 203ip</b>
Datenkabel Proximity/USB (2m) / Data cable Proximity/USB (2m)	<b>1850 204ip</b>

**Bluetooth-Dongel (USB)**

**Bluetooth-Dongle (USB)**

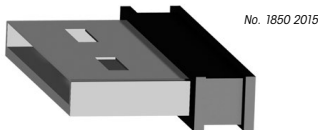

- ▶ Empfänger zur kabellosen Datenübertragung über Bluetooth
- ▶ Lieferung einzeln verpackt, inkl. Treiber und Gage-Wedge Software

- ▶ Receiver for wireless data transmission through Bluetooth
- ▶ Delivered in individual packages, incl. driver and Gage-Wedge Software

Typ Type	Nº
Bluetooth-Dongel (USB) / Bluetooth-Dongle (USB)	<b>1850 2015</b>

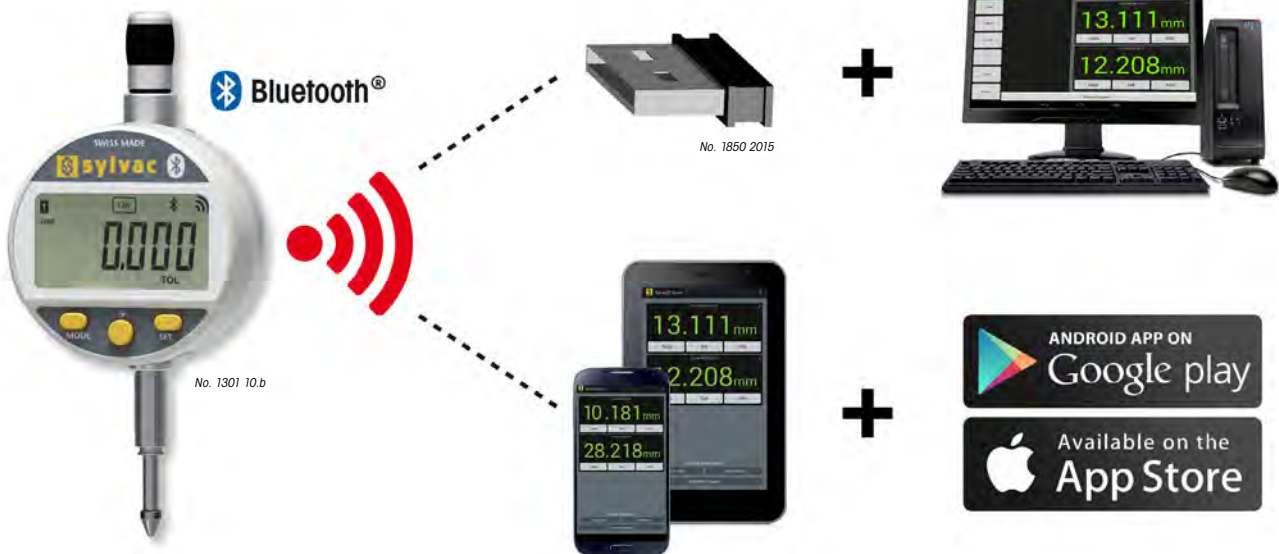

Bluetooth®

No. 1307 10.b

No. 1850 2015

ANDROID APP ON Google play

Available on the App Store

### Tastaturinterface für RS 232-Schnittstelle mit Tastatur-Interface

### Keyboardinterface for RS 232 interface with keyboard interface



- ▶ Datenkabel und Tastaturinterface in einem Gerät
- ▶ Stromversorgung durch USB-Schnittstelle
- ▶ USB-Interface wird als Tastatur erkannt
- ▶ Tastenfunktionen wie Enter, Tab, etc. sind programmierbar und werden automatisch mit gesendet
- ▶ Sprache, Trennzeichen und Timer einstellbar
- ▶ Datenimport in MS Excel etc. mit Data-Taste am Messmittel oder per Timer
- ▶ Lieferung einzeln verpackt, ohne Datenkabel

- ▶ Data cable and keyboard interface in one device
- ▶ Electronic power supply through USB interface
- ▶ USB-Interface will be identified as a keyboard
- ▶ Keyfunctions such as Enter, Tab, etc. are programmable and be sent automatically
- ▶ Languages, tag and timer are programmable
- ▶ Data import in MS Excel etc. through Data-Key on the measuring instrument or by timer
- ▶ Delivered in individual packages, without data cable

**I** zur Verwendung wird ein Datenkabel Opto RS 232 DUPLEX oder Proximity RS 232 benötigt.

**I** Data cable Opto RS 232 DUPLEX or Proximity RS 232 is necessary.

Typ Type	Nº
Tastaturinterface / Keyboardinterface	<b>1850 281</b>
Datenkabel Opto/RS 232 DUPLEX (2m) / Data cable Opto/RS 232 DUPLEX (2m)	<b>1850 205</b>
Datenkabel Proximity/RS 232 (2m) / Data cable Proximity/RS 232 (2m)	<b>1850 203ip</b>

### Datenübertragungskabel für Variable-Schnittstelle

### Data cable for Variable-Data output

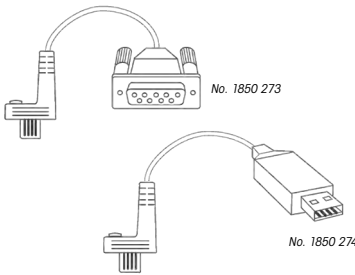

- ▶ Länge 2m
- ▶ Lieferung einzeln verpackt, inkl. Software für Datenimport in MS Excel etc.

- ▶ Length 2m
- ▶ Delivered in individual packages incl. software for data import in MS Excel etc.

Typ Type	Nº
Datenkabel RS232 (2m) / Data cable RS232 (2m)	<b>1850 273</b>
Datenkabel USB (2m) / Data cable USB (2m)	<b>1850 274</b>

### Großanzeigen LED für Opto-Schnittstelle

### Large LED-Display for Opto-Interface



Toleranzampel (rot, grün, gelb)  
und Funkübertragung auf Anfrage

Tolerance signal lights (red, green, yellow)  
and radio transmission on request

- ▶ zum sicheren und genauen Ablesen von Messwerten auch bei größerer Entfernung
- ▶ Unterstützung für Sehbehinderte
- ▶ Tochteranzeige für Messgeräte
- ▶ großes blendfreies LED-Display
- ▶ Anzeige für Umrechnungswerte, multiplizierende Funktion ermöglicht ein automatisches Anpassen der Messwerte (\*0,5 / \*1,0 / \*2,0 / \*3,1416)
- ▶ Dateneingang Opto RS 232 mit Datenkabel Nr. 1850 203
- ▶ Datenausgang Opto RS 232 mit Datenkabel (siehe Tabelle unten)
- ▶ Lieferung einzeln verpackt, inkl. Netzteil, ohne Toleranzampel

- ▶ For safe and accurate reading of measuring values even at a larger distance
- ▶ Support for visually handicapped persons
- ▶ Subsidiary display for measuring instruments
- ▶ Large antiglare LED-Display
- ▶ Indication for conversion values, multiplication function enables automatic adjustment of the measuring values (\*0,5 / \*1,0 / \*2,0 / \*3,1416)
- ▶ Data input Opto RS 232 with data cable No. 1850 203
- ▶ Data output Opto RS 232 with data cable (see table below)
- ▶ Delivered in individual packages, incl. main adapter, without tolerance signal lights

Ziffernhöhe / Digit height mm	Ziffern Digits	⊞ kg	Nº
57	6	1,7	<b>1850 250</b>
25	7	1,2	<b>1850 251</b>
Datenkabel RS232 (Anzeige/PC) / Data cable RS232 (2m) (Display/PC)			<b>1850 260</b>
Datenkabel USB (Anzeige/PC) / Data cable USB (2m) (Display/PC)			<b>1850 261</b>





**PC-Funkstation (Empfänger)  
zur kabellosen Datenübertragung**

**PC-Radio station (receiver)  
for wireless data transmission**

  **NEW**

- ▶ Empfänger für Sendermodule Nr. 1850 240 / 1850 241
- ▶ Keine Treiberdatei für die USB-Schnittstelle erforderlich
- ▶ Stromversorgung durch USB-Schnittstelle
- ▶ Datenimport in MS Excel etc. mit Data-Taste am Sendermodul
- ▶ Funkreichweite bis zu 200m
- ▶ Kommunikation mit bis zu 120 Funkmodulen
- ▶ Lieferung einzeln verpackt, inkl. Wandhalterung, USB-Datenkabel und Software

- ▶ Receiver for radio transmitter no. 1850 240 / 1850 241
- ▶ No driver file for the USB-Interface required
- ▶ Electronic power supply through USB-Interface
- ▶ Data import in MS Excel etc. through Data-Key on the radio transmitter
- ▶ Range of radio transmission up to 200m
- ▶ Communication with max. 120 radio transmitter
- ▶ Delivered in individual packages incl. wall bracket, USB data cable and software

- Funktionen der Software:**
- ▶ Programmierung der Sendermodule
  - ▶ Anzeigen von empfangenen Messwerten
  - ▶ Datenübergabe an Windows Programme

- Functions of the software:**
- ▶ Programming of the radio transmitter
  - ▶ Display of received measuring values
  - ▶ Data transfer to all Windows programs

Typ Type	Nº
USB-Empfänger / USB-Receiver	1850 245



**Sendermodule, kabellos  
für Funk-Datenübertragung**

**Radio transmitter, wireless  
for radio transmission**

  **NEW**

- ▶ Datenimport in MS Excel etc. mit Data-Taste am Sendermodul
- ▶ Sendermodul wird anstatt Datenkabel in den Datenausgang eingesteckt
- ▶ LED Toleranzampel (3 farbig)
- ▶ erfolgreiche Messwertübertragung: LED grün + Signalton
- ▶ fehlerhafte Messwertübertragung: LED rot + 2x Signalton
- ▶ Lieferung einzeln verpackt

- ▶ Data import in MS Excel etc. through Data-Key on the radio transmitter
- ▶ Radio transmitter have to be mounted in the data output (instead of the data cable)
- ▶ LED tolerance signal lights (3 colours)
- ▶ successful data transmission: LED green + beep signal
- ▶ failed data transmission: LED red + 2x beep signal
- ▶ Delivered in individual packages

**!** Als Empfänger wird eine PC-Funkstation Nr. 1850 245 benötigt.

**!** You need a PC-Radio station No. 1850 245 as a receiver.

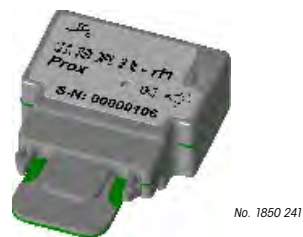

Typ Type	Nº
Sendermodul für Opto Sylvac System Radio transmitter for Opto Sylvac System	1850 240
Sendermodul für Proximity Sylvac System Radio transmitter for Proximity Sylvac System	1850 241

Andere Sendermodule (z.B. für Kröplin Schnelltaster) auf Anfrage  
Other radio transmitter (example for Kröplin dial calipers) on request

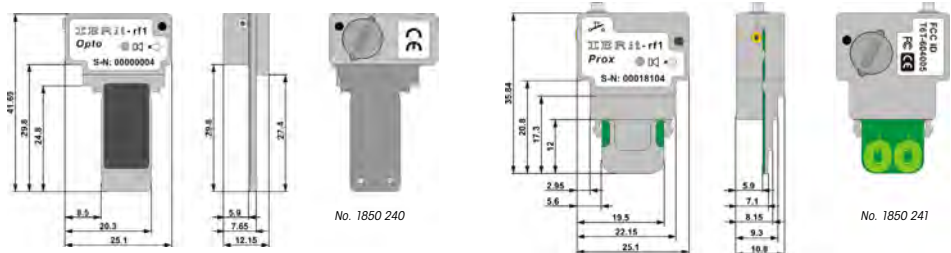

**Hand- und Fußtaster**

**Hand- and footswitch**

  **NEW**

- ▶ einfache Auslösung zur Datenübertragung am Hand- oder Fußtaster

- ▶ Simple data transmission through hand- and footswitch

**!** auf Anfrage

**!** on request

## Sonder-Messschieber

## Custom made vernier calipers



Wir liefern jede Art von Sonder-Messschiebern für Ihren speziellen Anwendungsfall – auf Wunsch auch Konzeption und Konstruktion, gegen Berechnung.

Zur Angebotserstellung bitten wir um Ihre Anfragen mit Zeichnungsunterlagen.

We supply all types of custom made vernier calipers for your special applications – on request also undertake conception and design at a cost.

For the preparation of a quotation, please send us your inquiries with drawings.

### Beispiele:

### Examples:

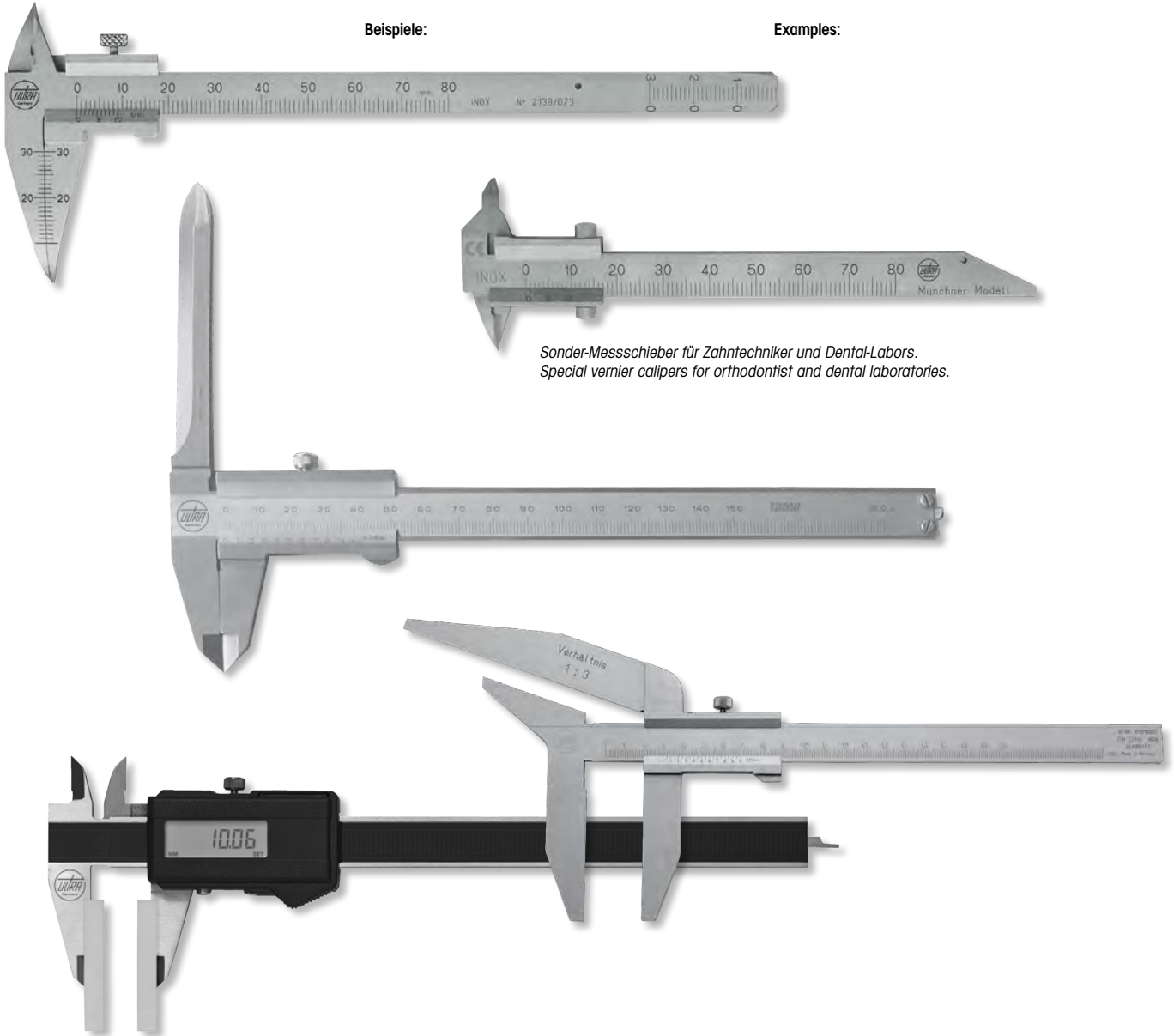

*Sonder-Messschieber für Zahntechniker und Dental-Labors.  
Special vernier calipers for orthodontist and dental laboratories.*

## Batterien für Digital-Messgeräte

## Batteries for digital measuring instruments



► Lieferung einzeln verpackt

► Delivered in individual packages



No. 1850 301



No. 1850 302

Spannung Voltage	mm	Nº
3,0 V	Ø 19,8 x 3,0	1850 301
1,5 V	Ø 11,5 x 5,2	1850 302



# 12

## Höhenmessgeräte

Height gauges

## Anreißgeräte

Scribing instruments

## Streichmaße

Marking gauges

## Zirkel

Dividers

## Reißnadeln

Scribers



**TOP**

Höhenmess- und Anreißgerät  
Height and marking gauges



12.2

TALMETER Anreißlehre  
TALMETER marking gauge



12.4

Stangenzirkel  
Trammels



12.6

Anreißfarben, Tuschkierpaste  
Marking paints, Surface paste



12.14



+49 (0) 60 21 42 999 00

1

2

3

4

5

6

7

8

9

10

11

12

13

14

15

## Digital-Höhenmess- und Anreißgeräte mit Doppelsäule

## Digital height and marking gauges with double columns



- ▶ Werksnorm
- ▶ Schutzart IP 54, Sylvac System
- ▶ Gussfuß, Säule Spezialstahl
- ▶ Schnellverstellung durch zentralen Druckknopf am Gehäuse
- ▶ Feinverstellung durch drehbare, zentrale Gewindespindel (Stellmutter bleibt immer an der gleichen, günstigen Position an der Fußoberfläche)
- ▶ großes LCD Display
- ▶ Anreißnadel Stahl gehärtet
- ▶ Lieferung im Holzetui

### Funktionen:

- ▶ Ein/Aus, mm/inch Umschaltung, O-Punkt an jeder Position
- ± Preset Funktion, Hold Funktion, Datenausgang Opto

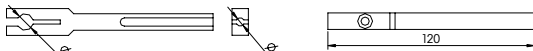

Messuhrhalter Aufnahme  $\varnothing$  4mm und 8mm  
Dial gauge holder mounting hole  $\varnothing$  4mm and 8mm

mm	inch	mm	inch	mm	Fuß / Base mm	kg	Nº	
300	12	0,01	.0005	0,06	117 x 204	5,5	1808 101	
600	24	0,01	.0005	0,06	117 x 204	9,0	1808 102	
1000	40	0,01	.0005	0,08	117 x 204	13,0	1808 103	
Anreißnadel Stahl gehärtet 70mm / Steel scriber hardened 70mm								1809 101
Anreißnadel Hartmetall 70mm / Tungsten carbide tipped scriber 70mm								1809 102
Anreißnadel Stahl gehärtet 120mm / Steel scriber hardened 120mm								1809 103
Messuhrhalter 120mm / Dial gauges holder 120mm								1809 202
Datenkabel RS232 (2m) / Data cable RS232 (2m)								1850 203
Datenkabel USB (2m) / Data cable USB (2m)								1850 204

- ▶ Works standard
- ▶ Protection class IP 54, Sylvac System
- ▶ Cast iron base with special steel columns
- ▶ Fast up and down with central push button
- ▶ Fine adjustment with knurled nut at a central threaded spindle
- ▶ Large LCD display
- ▶ Steel scriber, hardened
- ▶ Delivered in wooden case

### Functions:

- ▶ On/Off, mm/inch commutation, Zero setting at any position,  $\pm$  Preset function, Hold function, Data output Opto



No. 1808 101

## Digital-Höhenmess- und Anreißgeräte mit Doppelsäule

## Digital height and marking gauges with double columns



- ▶ Werksnorm
- ▶ Schutzart IP 54, Sylvac System
- ▶ Gussfuß, Säule Spezialstahl
- ▶ Verstellung durch Handrad
- ▶ Feineinstellung und Klemmung
- ▶ großes LCD Display
- ▶ Anreißnadel Stahl gehärtet
- ▶ Lieferung im Holzetui

### Funktionen:

- ▶ Ein/Aus, mm/inch Umschaltung, O-Punkt an jeder Position
- ± Preset Funktion, Hold Funktion, Datenausgang Opto

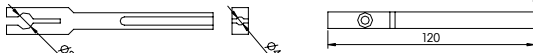

Messuhrhalter Aufnahme  $\varnothing$  4mm und 8mm  
Dial gauge holder mounting hole  $\varnothing$  4mm and 8mm

mm	inch	mm	inch	mm	Fuß / Base mm	kg	Nº	
300	12	0,01	.0005	0,06	107 x 174	7,0	1807 501	
400	16	0,01	.0005	0,06	107 x 174	8,0	1807 501x	
600	24	0,01	.0005	0,06	117 x 204	12,0	1807 502	
1000	40	0,01	.0005	0,08	117 x 204	16,0	1807 503	
Anreißnadel Stahl gehärtet 70mm / Steel scriber hardened 70mm								1809 101
Anreißnadel Hartmetall 70mm / Tungsten carbide tipped scriber 70mm								1809 102
Anreißnadel Stahl gehärtet 120mm / Steel scriber hardened 120mm								1809 103
Messuhrhalter 120mm / Dial gauges holder 120mm								1809 202
Datenkabel RS232 (2m) / Data cable RS232 (2m)								1850 203
Datenkabel USB (2m) / Data cable USB (2m)								1850 204

- ▶ Works standard
- ▶ Protection class IP 54, Sylvac System
- ▶ Cast iron base with special steel columns
- ▶ Adjustment by hand wheel
- ▶ Fine adjustment and clamping
- ▶ Large LCD display
- ▶ Steel scriber, hardened
- ▶ Delivered in wooden case

### Functions:

- ▶ On/Off, mm/inch commutation, Zero setting at any position,  $\pm$  Preset function, Hold function, Data output Opto



No. 1807 501

**Digital-Höhenmess- und Anreißgeräte mit Doppelsäule - CARBON**      **Digital height and marking gauges with double columns - CARBON**







- ▶ Werksnorm
- ▶ Schutzart IP 54, Sylvac System
- ▶ Gussfuß, Säule Spezialstahl Ø25mm
- ▶ Messstange aus Kohlefaser 48x16mm
- ▶ Schnellverstellung durch zentralen Druckknopf am Gehäuse
- ▶ Feinverstellung und Klemmung
- ▶ großes LCD Display
- ▶ Anreißnadel Stahl gehärtet
- ▶ Lieferung im Holzetui

- ▶ Works standard
- ▶ Protection class IP 54, Sylvac System
- ▶ Cast iron base with special steel columns Ø25mm
- ▶ Carbon fibre bar 48x16mm
- ▶ Fast up and down with central push button
- ▶ Fine adjustment and clamping
- ▶ Large LCD display
- ▶ Steel scriber, hardened
- ▶ Delivered in wooden case

**Funktionen:**

- ▶ Ein/Aus
- ▶ mm/inch Umschaltung
- ▶ 0-Punkt an jeder Position
- ▶ ± Preset Funktion
- ▶ Hold Funktion
- ▶ Datenausgang Opto

**Funktionen:**

- ▶ On/Off
- ▶ mm/inch commutation
- ▶ Zero setting at any position
- ▶ ± Preset function
- ▶ Hold function
- ▶ Data output Opto



! Anreißnadeln in anderen Längen auf Anfrage.

! Anreißnadeln in anderen Längen auf Anfrage.

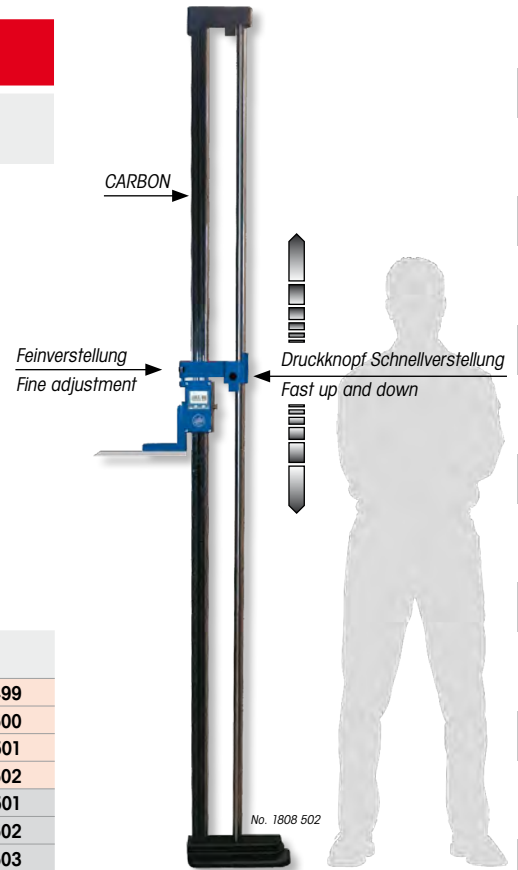
mm	inch	mm	inch	Fuß / Base mm	kg	Nº
600	24	0,01	.0005	120 x 190	8,4	1808 499
1000	40	0,01	.0005	120 x 190	11,5	1808 500
1500	60	0,01	.0005	117 x 204	18,0	1808 501
2000	80	0,01	.0005	186 x 320	32,0	1808 502
Anreißnadel Stahl gehärtet 200mm / Steel scriber hardened 200mm						1809 501
Anreißnadel Stahl gehärtet 300mm / Steel scriber hardened 300mm						1809 502
Anreißnadel Stahl gehärtet 600mm / Steel scriber hardened 600mm						1809 503
Datenkabel RS232 (2m) / Data cable RS232 (2m)						1850 203
Datenkabel USB (2m) / Data cable USB (2m)						1850 204



**Digital-Höhenmess- und Anreißgeräte STANDARD**      **Digital height and marking gauges STANDARD**

- ▶ Werksnorm
- ▶ Gussfuß, Schiene Spezialstahl
- ▶ Feineinstellung und Klemmung
- ▶ großes LCD Display
- ▶ Anreißnadel hartmetallbestückt
- ▶ Lieferung einzeln verpackt

- ▶ Works standard
- ▶ Cast iron base with special steel column
- ▶ Fine adjustment and clamping
- ▶ Large LCD display
- ▶ Tungsten carbide-tipped scriber
- ▶ Delivered in individual packages

**Funktionen:**

- ▶ Ein/Aus
- ▶ mm/inch Umschaltung
- ▶ 0-Punkt an jeder Position

**Funktionen:**

- ▶ On/Off
- ▶ mm/inch commutation
- ▶ Zero setting at any position

<b>1800 1.. :</b> Höhenmessgeräte	<b>1800 1.. :</b> Height gauge
<b>1802 1.. :</b> Holzetui	<b>1802 1.. :</b> Wooden box
<b>1800 5.. :</b> Anreißnadel Hartmetall	<b>1800 5.. :</b> Tungsten carbide tipped scriber

mm	inch	mm	inch	Fuß / Base mm	kg	Nº	Nº	Nº
300	12	0,01	.0005	65 x 110	4,0	1800 101s	1802 101	1800 501
600	24	0,01	.0005	65 x 110	4,5	1800 102s	1802 102	1800 502
1000	40	0,01	.0005	120 x 180	8,5	1800 103s	1802 103	1800 503



## Höhenmess- und Anreißgeräte STANDARD

## Vernier height and marking gauges STANDARD



- ▶ Werksnorm
- ▶ Feineinstellung und Klemmung
- ▶ Gussfuß, Schiene Spezialstahl
- ▶ Ablesung mit Vergrößerungsglas
- ▶ Ableseteile mattverchromt
- ▶ Anreißnadel hartmetallbestückt
- ▶ Lieferung einzeln verpackt

- ▶ Works standard
- ▶ Fine adjustment and clamping
- ▶ Cast iron base with special steel column
- ▶ Reading with magnifying glass
- ▶ Satin chrome reading parts
- ▶ Tungsten carbide-tipped scriber
- ▶ Delivered in individual packages

5094 5.. :

Anreißnadel Hartmetall

5094 5.. :

Tungsten carbide-tipped scriber

mm	mm	Fuß / Base mm	kg	Nº	Nº
300	1/50	85 x 125	3,5	5094 101	5094 501
450	1/50	85 x 125	7,5	5094 102	5094 502
600	1/50	120 x 180	8,5	5094 103	5094 503
1000	1/50	120 x 180	12,0	5094 104	5094 504

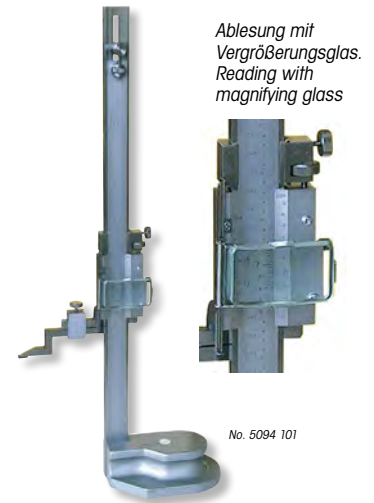

## Sonderanfertigungen

## Special measuring devices



Wir liefern jede Art von Sonderprüfvorrichtungen für Ihren speziellen Anwendungsfall – auf Wunsch auch Konzeption und Konstruktion, gegen Berechnung.

We supply all types of custom made testing system for your special applications – on request also undertake conception and design at a cost.

Zur Angebotserstellung bitten wir um Ihre Anfragen mit Zeichnungsunterlagen.

For the preparation of a quotation, please send us your inquiries with drawings.



## TALMETER Anreißlehre und Rollbandmaße

## TALMETER marking gauge and measuring tapes



- ▶ EG Klasse II
- ▶ Messen und Anreißn
- ▶ Federbandstahl lackiert
- ▶ Außenmaße = schwarze Ziffern
- ▶ Innenmaße = rote Ziffern
- ▶ Bandrücklauf automatisch
- ▶ Stoppaste, Klemmung
- ▶ ABS Gehäuse
- ▶ Lieferung einzeln verpackt

- ▶ EC class II
- ▶ Measuring and marking
- ▶ Lacquered spring steel
- ▶ Outer dimensions = black dial
- ▶ Inner dimensions = red dial
- ▶ Automatic tape return
- ▶ Stop button, clamping
- ▶ ABS housing
- ▶ Delivered in individual packages

5322 1.. :

Direktablesung von Ø

5322 1.. :

Direct reading for Ø

5322 2.. :

Direktablesung von Innenmaßen

5322 2.. :

Direct reading for inside measurement

5322 3.. :

Ersatzbänder

5322 3.. :

Spare tapes

m	mm	mm	kg	Nº	Nº
2	16	mm/mm	0,11	5322 101	5322 301
3	16	mm/mm	0,16	5322 102	5322 302
6	25	mm/mm	0,42	5322 202	5322 304



**Parallelreißer UNIVERSAL**  
Stange schwenkbar

**Surface gauges UNIVERSAL**  
Pivoting beam



- ▶ Reißnadel beliebig schwenkbar
- ▶ Gussfuß mit prismatischer Sohle
- ▶ Feineinstellung am Fuß
- ▶ Lieferung einzeln verpackt

- ▶ Freely adjustable scriber
- ▶ Cast iron base with V
- ▶ Beam with fine adjustment
- ▶ Delivered in individual packages

ℓ mm	∅ mm	Fuß / Base mm	⚖ kg	Nº
300	8	100 x 70 x 50	2,2	5100 101
500	10	100 x 70 x 50	2,5	5100 103



No. 5100 101

**Parallelreißer**

**Surface gauges**



- ▶ Reißnadel beliebig schwenkbar
- ▶ Gussfuß, runde Stange
- ▶ Lieferung einzeln verpackt

- ▶ Freely adjustable scriber
- ▶ Cast iron base with round beam
- ▶ Delivered in individual packages

! Andere Größen auf Anfrage.

! Other sizes on request.

ℓ mm	∅ mm	Fuß / Base ∅ mm	⚖ kg	Nº
300	10	85	2,4	5101 102
500	14	110	5,0	5101 104



No. 5101 102

**Zirkelmessschieber**

**Compass vernier calipers**



- ▶ Feststellschraube
- ▶ Spezialstahl
- ▶ Ableseteile mattverchromt
- ▶ Lieferung einzelverpackt

- ▶ Locking screw
- ▶ Special steel
- ▶ Satin chrome reading parts
- ▶ Delivered in individual packages

5108 1.. :

Anreißspitzen gehärtet

5108 1.. :

Hardened scriber points

5108 2.. :

Anreißspitzen hartmetallbestückt

5108 2.. :

Tungsten carbide-tipped scriber points

! Andere Größen auf Anfrage.

! Other sizes on request.

ℓ mm	für / for ∅ mm	ℓ mm	<∅ mm	⚖ kg	Nº	Nº
200	400	40	0,1	0,18	5108 103	5108 203
300	600	40	0,1	0,25	5108 105	5108 205



No. 5108 103

## Stangenzirkel

## Trammels



**Gehärtet  
Hardened**

- ▶ Feststellschraube
- ▶ Runde Stange aus Stahlrohr, mit 1/1mm Teilung
- ▶ Stahlspitzen gehärtet, auswechselbar
- ▶ Lieferung einzeln verpackt

- ▶ Locking screw
- ▶ Round steel-pipe beam, with 1/1mm graduation
- ▶ Interchangeable steel points hardened
- ▶ Delivered in individual packages



No. 5104 201

**5104 2.. :**

mit Feineinstellung

**5104 2.. :**

With fine adjustment

**5105 101 / 5105 102 :**

Ersatzspitzen Stahl gehärtet (Paar)

**5105 101 / 5105 102 :**

Spare points hardened steel (pair)

**!** Größere Messbereiche auf Anfrage.

**!** Larger measuring ranges on request.

∅ mm	Δ mm	∅ kg	Nº	Nº
500	1/10	0,9	5104 201	5105 101
1000	1/10	1,5	5104 202	5105 101
1500	1/10	2,1	5104 203	5105 101
2000	1/10	2,8	5104 204	5105 101
3000	1/10	5,5	5104 205	5105 102
4000	1/10	6,8	5104 206	5105 102
5000	1/10	8,1	5104 207	5105 102

> 5000mm auf Anfrage / on request

## Stangenzirkel

## Trammels



**Gehärtet  
Hardened**

- ▶ Feststellschraube
- ▶ Stange aus Flachstahl, mit 1/1mm Teilung
- ▶ Stahlspitzen auswechselbar, gehärtet
- ▶ Lieferung einzeln verpackt

- ▶ Locking screw
- ▶ Flat steel beam, with 1/1mm graduation
- ▶ Interchangeable steel points, hardened
- ▶ Delivered in individual packages

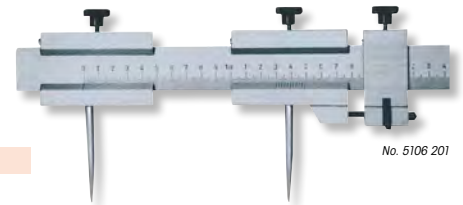

No. 5106 201

**5106 2.. :**

mit Feineinstellung

**5106 2.. :**

With fine adjustment

**5106 3.. :**

mit Feinverstellung durch Reibrad

**5106 3.. :**

With fine adjustment by friction wheel

**5107 101 :**

Ersatzspitzen Stahl gehärtet (Paar)

**5107 101 :**

Spare points hardened steel (pair)

**5107 201 :**

Ersatzspitzen Hartmetall (Paar)

**5107 201 :**

Spare points tungsten carbide (pair)



No. 5106 301

**!** Größere Messbereiche auf Anfrage.

**!** Larger measuring ranges on request.

∅ mm	Δ mm	∅ kg	Nº	Nº	Nº	Nº
500	1/10	2,6	5106 201	5106 301	5107 101	5107 201
1000	1/10	2,2	5106 202	5106 302	5107 101	5107 201
1500	1/10	2,9	5106 203	5106 303	5107 101	5107 201
2000	1/10	6,0	5106 204	5106 304	5107 101	5107 201
3000	1/10	8,7	5106 205	5106 305	5107 101	5107 201

> 3000mm auf Anfrage / on request

**Anreißmessschieber mit Laufrolle**

**Marking vernier calipers with roller**



**Gehärtet  
Hardened**

- ▶ Feststellschraube
- ▶ rostfreier Stahl, gehärtet
- ▶ Ableseteile mattverchromt
- ▶ Anreißspitze gehärtet, auswechselbar
- ▶ Lieferung in Kunstledertasche

- ▶ Locking screw
- ▶ Hardened stainless steel
- ▶ Satin chrome reading parts
- ▶ Interchangeable scriber hardened
- ▶ Delivered in imitation leather bag



No. 1905 201

**1905 201 / 1905 203:**

Anreißmessschieber

**1905 201 / 1905 203:**

Marking vernier calipers

**1905 3.. :**

Holzetui

**1905 3.. :**

Wooden box

**1905 205 :**

Ersatzspitze gehärtet

**1905 205 :**

Hardened spare point

mm		inch		kg	Nº	Nº
mm	inch	mm	inch			
200	8	1/10	1/128	0,18	1905 201	1905 301
400	16	1/10	1/128	0,36	1905 203	1905 303

**Anreißmessschieber**

**Marking vernier calipers**



**Gehärtet  
Hardened**

- ▶ Feineinstellung und Klemmung
- ▶ Spezialstahl, gehärtet
- ▶ Ableseteile mattverchromt
- ▶ Lieferung einzeln verpackt

- ▶ Fine adjustment and clamping
- ▶ Hardened special steel
- ▶ Satin chrome reading parts
- ▶ Delivered in individual packages

**1912 1.. :**

Anreißmessschieber

**1912 1.. :**

Marking vernier calipers

**1910 2.. :**

Holzetui

**1910 2.. :**

Wooden box

mm	mm	mm	kg	Nº	Nº
160	100	1/20	0,36	1912 101	1910 201
250	140	1/20	0,33	1912 102	1910 202
300	160	1/20	0,48	1912 103	1910 203
500	160	1/20	0,67	1912 105	1910 205

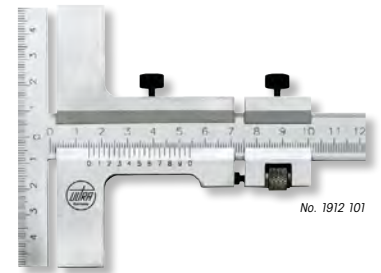

No. 1912 101

**Anreißmessschieber**

**Marking vernier calipers**



**Gehärtet  
Hardened**

- ▶ Feststellschraube
- ▶ rostfreier Stahl, gehärtet
- ▶ auswechselbare Anreißnadel, gehärtet
- ▶ Lieferung einzeln verpackt

- ▶ Locking screw
- ▶ Hardened stainless steel
- ▶ Hardened interchangeable scriber
- ▶ Delivered in individual packages

**5082 1.. :**

Anreißmessschieber

**5082 1.. :**

Marking vernier calipers

**5083 101 :**

Ersatzspitze gehärtet

**5083 101 :**

Hardened spare point

**5083 102 :**

Ersatzspitze Hartmetall

**5083 102 :**

Tungsten carbide spare point

mm	mm	mm	kg	Nº	Nº	Nº
200	110	1/20	0,36	5082 101	5083 101	5083 102
300	110	1/20	0,33	5082 102	5083 101	5083 102



No. 5082 101

## Streichmaß

## Marking gauges



- ▶ Feststellschraube
- ▶ runde Stange aus Stahl, mit 1/1mm Teilung
- ▶ auswechselbare Anreißnadel, gehärtet
- ▶ Lieferung einzeln verpackt

- ▶ Locking screw
- ▶ Round steel beam, with 1/1mm graduation
- ▶ Hardened interchangeable scriber
- ▶ Delivered in individual packages

**5112 1.. :**  
eckiger Anschlag, mit Feineinstellung

**5112 1.. :**  
Angular back, with fine adjustment

**5113 1.. :**  
runder Anschlag, ohne Feineinstellung

**5113 1.. :**  
Round back, without fine adjustment

mm	mm	kg	Nº	Nº
200	1/10	0,4	5112 101	-
300	1/10	0,5	5112 102	5113 102
400	1/10	0,6	5112 103	-
500	1/10	0,7	5112 104	5113 104
Ersatzspitze gehärtet / Hardened spare point			5114 101	5114 103



## Streichmaß

## Marking gauges



- ▶ Feststellschraube
- ▶ Flachstahl rostfrei mit 1/1mm Teilung
- ▶ Anreißkante gehärtet
- ▶ Ableseteile, mattverchromt
- ▶ Lieferung einzeln verpackt

- ▶ Locking screw
- ▶ Flat stainless steel with 1/1mm graduation
- ▶ hardened marking edge
- ▶ Satin chrome reading parts
- ▶ Delivered in individual packages

mm	mm	kg	Nº
200	1/1	0,42	5115 101
250	1/1	0,45	5115 102
300	1/1	0,5	5115 103



## Fräseinstelllehre

## Milling tool setting gauges



- ▶ Feststellschraube
- ▶ rostfreier Stahl, Anschlagfläche gehärtet
- ▶ Anschlaglänge 100mm
- ▶ Ableseteile mattverchromt
- ▶ Lieferung einzeln verpackt

- ▶ Locking screw
- ▶ Stainless steel, stop face hardened
- ▶ Length of stop plate 100mm
- ▶ Satin chrome reading parts
- ▶ Delivered in individual packages

mm	mm	mm	kg	Nº
200	80	1/20	0,27	5091 102
300	80	1/20	0,31	5091 103





**Spitzzirkel**

**Dividers**



**Gehärtet  
Hardened**

- ▶ Nietscharnier
- ▶ Spitzen gehärtet
- ▶ Lieferung einzeln verpackt

- ▶ Rivet hinge
- ▶ Hardened points
- ▶ Delivered in individual packages

**5124 1.. :**  
Spitzzirkel

**5124 1.. :**  
Dividers

**5125 1.. :**  
Spitzzirkel mit Stellbogen

**5125 1.. :**  
Dividers with setting wing

**5126 1.. :**  
Spitzzirkel mit Stellbogen und Bleistifthalter

**5126 1.. :**  
Dividers with setting wing and pencil holder

**!** Größere Schenkellängen auf Anfrage.

**!** Longer legs on request.

A mm	█ kg	Nº	Nº	Nº
150	0,1	5124 101	5125 101	5126 101
200	0,18	5124 102	5125 102	5126 102
250	0,26	5124 103	5125 103	5126 103
300	0,33	5124 104	5125 104	5126 104
400	0,75	5124 105	5125 105	5126 105
500	0,9	5124 106	5125 106	5126 106



**Innen- und Außentaster**

**Inside and outside calipers**



- ▶ Nietscharnier
- ▶ Lieferung einzeln verpackt

- ▶ Rivet hinge
- ▶ Delivered in individual packages

**5127 1.. :**  
Lochzirkel innen

**5127 1.. :**  
Inside calipers

**5128 1.. :**  
Greifzirkel außen

**5128 1.. :**  
Outside calipers

**!** Größere Schenkellängen auf Anfrage.

**!** Longer legs on request.

A mm	█ kg	Nº	Nº
150	0,05	5127 101	5128 101
200	0,1	5127 102	5128 102
250	0,16	5127 103	5128 103
300	0,2	5127 104	5128 104
400	0,46	5127 105	5128 105
500	0,6	5127 106	5128 106

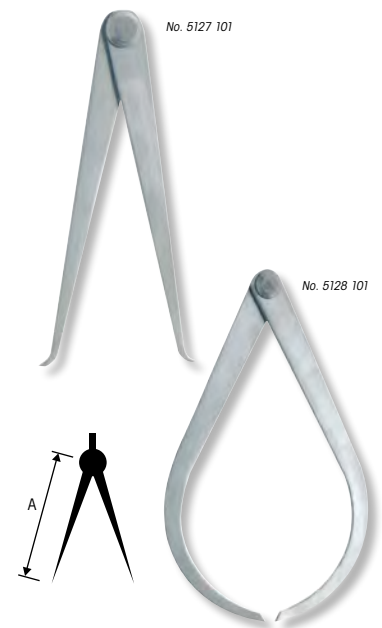

## Federspitzzirkel

## Spring dividers



**Gehärtet  
Hardened**

- ▶ Vierkantschenkel
- ▶ Schnellverstellung
- ▶ Spitzen gehärtet
- ▶ Lieferung einzeln verpackt

- ▶ Square legs
- ▶ Quick setting
- ▶ Hardened points
- ▶ Delivered in individual packages

**5129 1.. :**  
Spitzen fest

**5129 1.. :**  
Fixed points

**5129 2.. :**  
Spitzen auswechselbar

**5129 2.. :**  
Interchangeable points

**5130 101 :**  
Ersatzspitzen gehärtet (Paar)

**5130 101 :**  
Spare points hardened (pair)

**5130 201 :**  
Ersatzspitzen Hartmetall (Paar)

**5130 201 :**  
Spare points tungsten carbide (pair)

A mm	█ kg	Nº	Nº
75	0,06	5129 101	5129 201
100	0,08	5129 102	5129 202
125	0,1	5129 103	5129 203
150	0,11	5129 104	5129 204
175	0,13	5129 105	5129 205
200	0,14	5129 106	5129 206
250	0,18	5129 107	5129 207
300	0,22	5129 108	5129 208
400	0,33	5129 109	5129 209
500	0,5	5129 110	5129 210
600	0,62	5129 111	5129 211



## Federzirkel

## Spring calipers



**Gehärtet  
Hardened**

- ▶ Vierkantschenkel
- ▶ Schnellverstellung
- ▶ Messenden gehärtet
- ▶ Lieferung einzeln verpackt

- ▶ Square legs
- ▶ Quick setting
- ▶ Hardened measuring ends
- ▶ Delivered in individual packages

**5131 1.. :**  
Lochzirkel innen

**5131 1.. :**  
Inside caliper

**5132 1.. :**  
Greifzirkel außen

**5132 1.. :**  
Outside caliper

A mm	█ kg	Nº	Nº
75	0,06	5131 101	5132 101
100	0,08	5131 102	5132 102
125	0,1	5131 103	5132 103
150	0,11	5131 104	5132 104
175	0,13	5131 105	-
200	0,14	5131 106	5132 106
250	0,18	5131 107	5132 107
300	0,22	5131 108	5132 108
400	0,33	5131 109	5132 109
500	0,5	5131 110	5132 110
600	0,62	5131 111	5132 111



**Spitzzirkel**

**Dividers**



**Gehärtet  
Hardened**

- ▶ Schraubenscharnier
- ▶ flache Stahlschenkel
- ▶ auswechselbare Spitzen, gehärtet
- ▶ Lieferung einzeln verpackt

- ▶ Screw hinge
- ▶ Flat steel leg
- ▶ Hardened interchangeable points
- ▶ Delivered in individual packages

**5134 1.. :**  
ohne Stellbogen

**5134 1.. :**  
Without setting wing

**5134 2.. :**  
mit Stellbogen

**5134 2.. :**  
With setting wing

**5135 101 / 5135 102 :**  
Ersatzspitzen gehärtet (Paar)

**5135 101 / 5135 102 :**  
Spare points hardened (pair)

**5135 201 / 5135 202 :**  
Ersatzspitzen Hartmetall (Paar)

**5135 201 / 5135 202 :**  
Spare points tungsten carbide (pair)

A mm	⚖ kg	Nº	Nº	Nº	Nº
150	0,11	5134 101	5134 201	5135 101	5135 201
200	0,17	5134 102	5134 202	5135 101	5135 201
250	0,23	5134 103	5134 203	5135 101	5135 201
300	0,30	5134 104	5134 204	5135 101	5135 201
400	0,45	5134 105	5134 205	5135 102	5135 202
500	0,70	5134 106	5134 206	5135 102	5135 202



**Außen- und Innentaster**

**External and internal caliper**



- ▶ Nietscharnier
- ▶ Spezialstahl mit 1/1mm Teilung
- ▶ Ableseteile, mattverchromt
- ▶ Lieferung einzeln verpackt

- ▶ Rivet hinge
- ▶ Steel with 1/1mm graduation
- ▶ Satin chrome reading parts
- ▶ Delivered in individual packages

∅ mm	Δε mm	∏ mm	⚖ kg	Nº
120 - 0 - 120	1	190	0,2	5116 201
160 - 0 - 160	1	250	0,3	5116 202
200 - 0 - 200	1	310	0,5	5116 203
300 - 0 - 300	1	460	0,9	5116 205



1  
2  
3  
4  
5  
6  
7  
8  
9  
10  
11  
12  
13  
14  
15

## Reißnadeln, Stahl

## Scribers, steel



**Gehärtet  
Hardened**

- ▶ Chrom Vanadium Stahl, gehärtet
- ▶ aus einem Stück mit Ring
- ▶ 1 gerade Spitze
- ▶ Lieferung einzeln verpackt

- ▶ Hardened chrome vanadium steel
- ▶ Single piece with ring
- ▶ 1 straight point
- ▶ Delivered in individual packages

l mm	Ø mm	kg	Nº
200	4	0,02	<b>5118 101</b>



No. 5118 101

## Reißnadeln, Stahl

## Scribers, steel



**Gehärtet  
Hardened**

- ▶ Chrom Vanadium Stahl, gehärtet
- ▶ aus einem Stück, Griff gerändelt
- ▶ Lieferung einzeln verpackt

- ▶ Hardened chrome vanadium steel
- ▶ Single piece with knurled handle
- ▶ Delivered in individual packages

### 5118 102 :

1 gerade Spitze

### 5118 102 :

1 straight point

### 5118 104 :

1 gerade und 1 abgewinkelte Spitze

### 5118 104 :

1 straight and 1 bent point

l mm	Ø mm	kg	Nº
180	8	0,03	<b>5118 102</b>
190	4	0,03	<b>5118 104</b>



No. 5118 102

No. 5118 104

## Reißnadeln, Stahl

## Scribers, steel



**Gehärtet  
Hardened**

- ▶ Chrom Vanadium Stahl, gehärtet
- ▶ Griff gerändelt
- ▶ Spitzen eingeschraubt
- ▶ Lieferung einzeln verpackt

- ▶ Hardened chrome vanadium steel
- ▶ Knurled handle
- ▶ Screwed-in points
- ▶ Delivered in individual packages

### 5118 107 :

1 gerade Spitze

### 5118 107 :

1 straight point

### 5118 108 :

1 gerade und 1 abgewinkelte Spitze

### 5118 108 :

1 straight and 1 bent point

### 5119 101 :

Ersatzspitze gerade

### 5119 101 :

Straight spare point

### 5119 102 :

Ersatzspitze abgewinkelt

### 5119 102 :

Bent spare point

l mm	Ø mm	kg	Nº
175	4/8	0,04	<b>5118 107</b>
250	4/8	0,05	<b>5118 108</b>



No. 5118 107

No. 5118 108

**Reißnadeln, Hartmetall**

**Scribers, tungsten carbide**



- ▶ Sechskantgriff
- ▶ 1 gerade Spitze
- ▶ Lieferung einzeln verpackt

- ▶ Hexagonal handle
- ▶ 1 straight point
- ▶ Delivered in individual packages

**5120 101 :**  
Spitze fest

**5120 101 :**  
Fixed point

**5120 105 :**  
Spitze auswechselbar

**5120 105 :**  
Interchangeable point

**5119 203 :**  
Ersatzspitze

**5119 203 :**  
Spare point

**5121 201 :**  
Ansteckclip

**5121 201 :**  
Fixing clip

l mm	∅ mm	⚖ kg	Nº
150	6	0,04	5120 101
140	6	0,05	5120 105



**Reißnadeln, Hartmetall**

**Scribers, tungsten carbide**



- ▶ Griff gerändelt
- ▶ Spitzen eingeschraubt
- ▶ Lieferung einzeln verpackt

- ▶ Knurled handle
- ▶ Screwed-in points
- ▶ Delivered in individual packages

**5120 103 :**  
1 gerade Spitze

**5120 103 :**  
1 straight point

**5120 104 :**  
1 gerade und 1 abgewinkelte Spitze

**5120 104 :**  
1 straight and 1 bent point

**5119 201 :**  
Ersatzspitze gerade

**5119 201 :**  
Straight spare point

**5119 202 :**  
Ersatzspitze abgewinkelt

**5119 202 :**  
Bent spare point

l mm	∅ mm	⚖ kg	Nº
175	4/8	0,04	5120 103
250	4/8	0,05	5120 104



**Reißnadeln, Hartmetall**

**Scribers, tungsten carbide**



- ▶ Kunststoffschaft
- ▶ Fallmechanik
- ▶ Ansteckclip
- ▶ 1 gerade Spitze auswechselbar
- ▶ Lieferung einzeln verpackt

- ▶ Plastic shaft
- ▶ Drop-down mechanism
- ▶ Fixing clip
- ▶ 1 straight interchangeable point
- ▶ Delivered in individual packages

**5120 106 :**  
Reißnadel, Hartmetall

**5120 106 :**  
Scribers, tungsten carbide

**5119 204 :**  
Ersatzspitze

**5119 204 :**  
Spare point

l mm	∅ mm	⚖ kg	Nº
150	2/8	0,04	5120 106



## Anreißfarben

## Marking paints



- ▶ zum Anreißen und Markieren von Werkstücken
- ▶ schnelltrocknend ohne abzublättern
- ▶ Verarbeitung mit Pinsel oder als Spray (FCKW frei)
- ▶ Lieferung Spraydose oder Flasche einzeln verpackt

- ▶ For the scribing and marking of work pieces
- ▶ Quick dry without peeling off
- ▶ Working with brush or as spray (CFC-free)
- ▶ Delivered in individually packed spray cans or bottles

**I** Farbe weiß auf Anfrage.

**I** White colour on request.

Gebinde Packaging	Farbe Colour	Inhalt / Contents ml	Nº
Streichstift / Colour pencil	blau / blue	-	1532 100
Spray / Spray	blau / blue	300	1532 101
Flasche / Bottle	blau / blue	500	1532 103
Spray / Spray	rot / red	300	1532 102
Flasche / Bottle	rot / red	500	1532 104



No. 1532 100



No. 1532 101



No. 1532 103

## Lösemittelspray für Anreißfarben

## Solvent spray for marking colours



- ▶ zur allgemein Reinigung von Werkstücken
- ▶ besonders zum Entfernen von Anreißfarbe geeignet
- ▶ Lieferung in Spraydose einzeln verpackt

- ▶ For the general cleaning of work pieces
- ▶ Especially suitable for the removal of marking colours
- ▶ Delivered in individually packed spray cans

Gebinde Packaging	Inhalt / Contents ml	Nº
Spray / Spray	300	1532 301



No. 1532 301

## Tuschierpaste

## Surface paste



- ▶ zur Oberflächenkontrolle von Werkstücken
- ▶ die Gleichmäßigkeit der Farbschicht zeigt die Qualität der Bearbeitung an
- ▶ Lieferung in Tube oder Dose einzeln verpackt

- ▶ For the surface inspection of colour coat pieces
- ▶ The uniformity of the colour coat indicates the quality of the machining
- ▶ Delivered in individual tube or box

**I** Hitzebeständige Tuschierpaste auf Anfrage

**I** Heat-resistant surface paste on request

Gebinde Packaging	Farbe Colour	Inhalt / Contents g	Nº
Tube / Tube	blau / blue	60	1532 201
Dose / Box	blau / blue	225	1532 203
Tube / Tube	rot / red	70	1532 202
Dose / Box	rot / red	225	1532 204



No. 1532 201



No. 1532 203

## Spezialreiniger für Tuschierpasten

## Special cleaner for surface pastes



- ▶ zur allgemein Reinigung von Werkstücken, löst Wachs, Fett und Schmutz
- ▶ besonders zum Entfernen von Tuschierpaste geeignet
- ▶ Lieferung in Flasche oder Kanister einzeln verpackt

- ▶ For the general cleaning of work pieces; dissolves wax, fat and dirt
- ▶ Especially suitable for the removal of surface pastes
- ▶ Delivered in individually packed bottle or canister

Gebinde Packaging	Inhalt / Contents l	Nº
Flasche / Bottle	1	1532 401
Kanister / Canister	10	1532 402
Kanister / Canister	20	1532 403



No. 1532 401



No. 1532 402

# 13

## Bügelmessschrauben

External micrometers

## Einbaumessschrauben

Micrometer heads

## Höhenmikrometer

Height micrometer

## Tiefenmessschrauben

Depth micrometers

## Innenmessschrauben

Internal micrometers

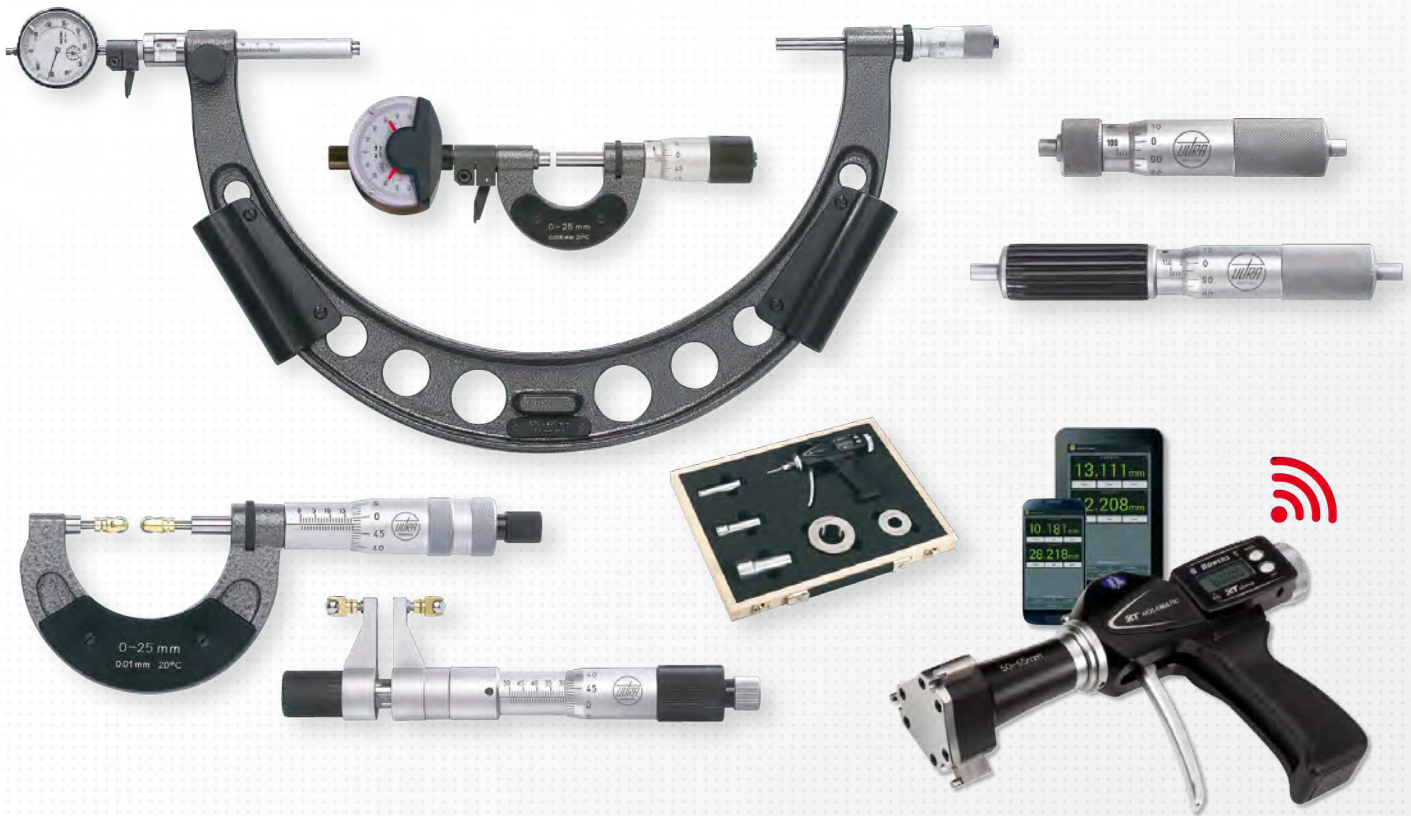

★ **NEW**

Messschrauben für Außengewindemessung  
Micrometer for thread measurements



13.16

Messschrauben für Verzahnungsmessung  
Micrometers for gear measurements



13.23

Innenmessschrauben mit Zapfen  
Internal micrometers with pins



13.36

Sondermessgeräte  
Special measuring devices



13.44

## Messschrauben nach DIN 863

Messschrauben sind nach DIN 863 Teil 1 – 4 genormt.  
 Teil 1: Bügelmessschrauben, Normalausführung  
 Teil 2: Einbaumessschrauben, Tiefenmessschrauben  
 Teil 3: Bügelmessschrauben, Sonderausführungen  
 Teil 4: Innenmessschrauben

### Fehlergrenzen für Bügelmessschrauben nach DIN 863 Teil 1:

**Werte A** = Abweichungsspanne der Anzeige  
**Werte B** = Parallelität der Messflächen  
**Werte C** = Aufbiegung des Bügels

Die in der Tabelle angegebenen Werte setzen eine Messkraft von 5 – 10N voraus. Die Toleranzen unserer Messschrauben sind in der Regel geringer als die nach DIN zulässigen Werte.

mm	A μ	B μ	C μ
0 – 25	4	2	2
25 – 50	4	2	2
50 – 75	5	3	3
75 – 100	5	3	3
100 – 125	6	3	4
125 – 150	6	3	5
150 – 175	7	4	6
175 – 200	7	4	6
200 – 225	8	4	7
225 – 250	8	4	8

## Micrometers according to DIN 863

Micrometers are standardised Part 1 – 4 according to DIN 863.  
 Part 1: External micrometers, normal model  
 Part 2: Micrometer heads, depth micrometers  
 Part 3: External micrometers, special models  
 Part 4: Internal micrometers

### Error limits for external micrometers according to DIN 863 Part 1:

**Values A** = Deviation range of the indication  
**Values B** = Parallelism of the measuring surfaces  
**Values C** = Bending up of the frame

The values specified in the table presupposes a measuring force of 5 – 10N. The tolerances of our micrometers are usually lower than the DIN permissible values.

mm	A μ	B μ	C μ
250 – 275	9	5	9
275 – 300	9	5	9
300 – 325	10	5	10
325 – 350	10	5	10
350 – 375	11	6	11
375 – 400	11	6	12
400 – 425	12	6	12
425 – 450	12	6	13
450 – 475	13	7	14
475 – 500	13	7	15

### Ableseung Skalentrommel

Je nach Ausführung der Mikrometer kommen folgende Varianten zum Einsatz:



Ableseung 0,01mm, Spindelsteigung 0,5mm  
 (50 Teilstriche auf der Trommel)

Reading 0.01 mm, spindle pitch 0.5 mm  
 (50 graduation marks on the drum)



Ableseung 0,01mm, Spindelsteigung 1,0mm  
 (100 Teilstriche auf der Trommel,  
 Ableseung ohne Addition)

Reading 0.01 mm, spindle pitch 1.0 mm  
 (100 graduation marks on the drum,  
 reading without addition)



Ableseung 0,005mm, Spindelsteigung 0,5mm  
 (100 Teilstriche auf der Trommel)

Reading 0.005 mm, spindle pitch 0.5 mm  
 (100 graduation marks on the drum)

### Kalibrierung:

Für alle Messschrauben können, Werkskalibrierscheine erstellt werden. Eine DAkkS-Kalibrierung durch ein akkreditiertes Labor ist für viele Typen ebenfalls möglich. Bitte beachten Sie hierzu unsere Nettopreisliste für die Erstellung von Prüfberichten.

Weitere Informationen erhalten Sie unter:

[www.ultra-germany.com](http://www.ultra-germany.com) > Produkte > Service > Prüfmittelüberwachung

### Messschrauben mit Sondermessflächen und Sonderanfertigungen:

Wir liefern Messschrauben mit besonderen Messflächenformen (siehe Seite 13.18) sowie jede Art von feinmechanischen Bauteilen und Spindelantrieben nach Ihren Zeichnungen – auf Wunsch auch Konzeption und Konstruktion, gegen Berechnung.

Zur Angebotserstellung bitten wir um Ihre Anfrage mit Zeichnungsunterlagen.

### Beispiele für kundenspezifische Sonderlösungen:

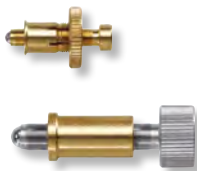

### Reading of scale drum

According to the model of the micrometer, the following versions are used:

### Calibration:

Works calibration certificates are issued for all micrometers. A DAkkS calibration certificate from an accredited laboratory is likewise possible for many types. Please check our net price list for the issue of inspection reports.

More information can be had at:

[www.ultra-germany.com](http://www.ultra-germany.com) > Products > Service > Calibration

### Micrometers with special measuring faces and special devices:

We supply micrometers with special measuring face shapes (see page 13.18), and all types of fine mechanical devices and spindle drives according to your drawings – on request also undertake conception and design at a cost.

For the preparation of a quotation, please send us your inquiries with drawings.

### Examples of customer-specific special solutions:



## Digital-Bügelmessschrauben Präzisionsausführung

## Digital external micrometers Precision model



- ▶ DIN 863
- ▶ Sylvac System
- ▶ großes LCD Display
- ▶ Hartmetallmessflächen Ø8mm
- ▶ nichtdrehende Spindel
- ▶ Spindelsteigung 1mm
- ▶ Messkraft 5 – 10 N
- ▶ Handwärmeschutz
- ▶ Lieferung im Etui ohne Einstellmaß

### Funktionen:

- ▶ Ein/Aus, mm/inch Umschaltung, 0-Punkt an jeder Position, Ablesung umschaltbar 0,01/0,001mm, Preset Funktion, Toleranzwerteingabe, Hold Funktion, Datenausgang Opto

- ▶ DIN 863
- ▶ Sylvac System
- ▶ Large LCD display
- ▶ Tungsten carbide-tipped measuring faces Ø8mm
- ▶ Non-turning spindle
- ▶ Spindle pitch 1 mm
- ▶ Measuring force 5 – 10 N
- ▶ Insulated pads
- ▶ Delivered in a case without setting gauge

### Functions:

- ▶ On/Off, mm/inch commutation, Zero setting at any position, Reversible reading 0.01/0.001mm, Preset function, Tolerance input, Hold function, Data output Opto

### 2013 1.. :

Gefühlsratsche, Spindelklemmung mit Hebel

### 2013 1.. :

Ratchet stop, spindle clamping with lever

### 2013 2.. :

mit Anlüftung ca. 2mm, mit Hebel  
konstante Messkraft durch federbelastete Spindel

### 2013 2.. :

With lifting device approx. 2mm, with lever  
constant measuring force through spring-loaded spindle

### 2037 1.. :

Einstellmaße

### 2037 1.. :

Setting gauge

! Größere Messbereiche sowie andere  
Messflächenformen auf Anfrage.

! Larger measuring ranges and other  
types of measuring faces on request.

mm	inch approx.	mm / inch	kg	Nº	Nº	Nº
0 – 25	0 – 1	0,01 / .0005 0,001 / .00005	0,74	2013 101	2013 201	-
25 – 50	1 – 2	0,01 / .0005 0,001 / .00005	0,84	2013 102	2013 202	2037 101
50 – 75	2 – 3	0,01 / .0005 0,001 / .00005	0,9	2013 103	2013 203	2037 102
75 – 100	3 – 4	0,01 / .0005 0,001 / .00005	1,18	2013 104	2013 204	2037 103
100 – 125	4 – 5	0,01 / .0005 0,001 / .00005	1,3	2013 105	2013 205	2037 104
125 – 150	5 – 6	0,01 / .0005 0,001 / .00005	1,6	2013 106	2013 206	2037 105
150 – 175	6 – 7	0,01 / .0005 0,001 / .00005	1,9	2013 107	2013 207	2037 106
175 – 200	7 – 8	0,01 / .0005 0,001 / .00005	2,3	2013 108	2013 208	2037 107

> 200mm auf Anfrage / on request

Datenkabel RS232 (2m) / Data cable RS232 (2m)

1850 203

Datenkabel USB (2m) / Data cable USB (2m)

1850 204



## Bügelmessschrauben STANDARD mit Zählwerk

## External micrometers, STANDARD with counter



- ▶ DIN 863
- ▶ Spindelsteigung 0,5mm
- ▶ Ablesefläche mattverchromt
- ▶ Hartmetallmessflächen Ø6,5mm
- ▶ Spindelklemmung
- ▶ Gefühlsratsche
- ▶ Handwärmeschutz
- ▶ Lieferung im Etui ab 25 – 50mm mit Einstellmaß

- ▶ DIN 863
- ▶ Spindle pitch 0.5mm
- ▶ Satin chrome reading parts
- ▶ Tungsten carbide measuring faces Ø6.5mm
- ▶ Spindle clamping
- ▶ Ratchet stop
- ▶ Insulated pads
- ▶ Delivered in a case; from 25 – 50mm with setting gauge

mm	mm	kg	Nº
0 – 25	0,01	0,35	5003 201
25 – 50	0,01	0,45	5003 202
50 – 75	0,01	0,6	5003 203
75 – 100	0,01	0,65	5003 204



## Digital-Bügelmessschrauben Präzisionsausführung

## Digital external micrometers Precision model



**Hartmetall  
Tungsten carbide**

- ▶ DIN 863
- ▶ großes LCD Display
- ▶ Hartmetallmessflächen Ø6,5mm
- ▶ Spindelklemmung mit Hebel
- ▶ Gefühlsratsche
- ▶ Messkraft 5 – 10 N
- ▶ Handwärmeschutz
- ▶ Lieferung im Etui; ab 25 – 50mm mit Einstellmaß

### Funktionen:

- ▶ Ein/Aus
- ▶ mm/inch Umschaltung
- ▶ O-Punkt an jeder Position
- ▶ Preset Funktion
- ▶ Datenausgang Variabel

- ▶ DIN 863
- ▶ Large LCD display
- ▶ Tungsten carbide-tipped measuring faces Ø6.5mm
- ▶ Spindle clamping with lever
- ▶ Ratchet stop
- ▶ Measuring force 5 – 10 N
- ▶ Insulated pads
- ▶ Delivered in a case; from 25 – 50mm with setting gauge

### Functions:

- ▶ On/Off
- ▶ mm/inch commutation
- ▶ Zero setting at any position
- ▶ Preset function
- ▶ Data output Variabel



No. 2015 101

mm	inch approx.	mm	inch	kg	Nº
0 – 25	0 – 1	0,001	.00005	0,3	2015 101
25 – 50	1 – 2	0,001	.00005	0,4	2015 102
50 – 75	2 – 3	0,001	.00005	0,5	2015 103
75 – 100	3 – 4	0,001	.00005	0,55	2015 104
Datenkabel RS232 (2m) / Data cable RS232 (2m)					1850 273
Datenkabel USB (2m) / Data cable USB (2m)					1850 274

## Digital-Bügelmessschrauben STANDARD

## Digital external micrometers STANDARD



**TOP**



**Hartmetall  
Tungsten carbide**

- ▶ DIN 863
- ▶ Schutzart IP54
- ▶ großes LCD Display
- ▶ Hartmetallmessflächen Ø6,5mm
- ▶ Spindelsteigung 0,5mm
- ▶ Spindelklemmung mit Hebel
- ▶ Gefühlsratsche
- ▶ Messkraft 5 – 10 N
- ▶ Handwärmeschutz
- ▶ Lieferung im Etui ab 25 – 50mm mit Einstellmaß

### Funktionen:

- ▶ Ein/Aus
- ▶ mm/inch Umschaltung
- ▶ O-Punkt an jeder Position
- ▶ Preset Funktion
- ▶ ABS/INC umschaltbar

- ▶ DIN 863
- ▶ Protection class IP54
- ▶ Large LCD display
- ▶ Tungsten carbide-tipped measuring faces Ø6.5mm
- ▶ Spindle pitch 0.5mm
- ▶ Spindle clamping with lever
- ▶ Ratchet stop
- ▶ Measuring force 5 – 10 N
- ▶ Insulated pads
- ▶ Delivered in a case; from 25 – 50mm with setting gauge

### Functions:

- ▶ On/Off
- ▶ mm/inch commutation
- ▶ Zero setting at any position
- ▶ Preset function
- ▶ ABS/INC reversible



No. 5000 201

mm	inch approx.	mm	inch	kg	Nº
0 – 25	0 – 1	0,001	.00005	0,27	5000 201
25 – 50	1 – 2	0,001	.00005	0,32	5000 202
50 – 75	2 – 3	0,001	.00005	0,47	5000 203
75 – 100	3 – 4	0,001	.00005	0,61	5000 204
100 – 125	4 – 5	0,001	.00005	0,57	5000 205
125 – 150	5 – 6	0,001	.00005	0,72	5000 206

**Feinzeiger-Messschrauben**

**External micrometers with comparator gauge**



- ▶ DIN 863
- ▶ Feinzeiger DIN 879
- ▶ Ablesung Mikrometer 0,01mm
- ▶ Hartmetallmessflächen Ø8mm
- ▶ Spindelsteigung 0,5mm
- ▶ Spindelklemmung mit Hebel
- ▶ Anlüftung ca. 2,5mm mit Druckknopf
- ▶ konstante Messkraft, federbelasteter Amboss
- ▶ Handwärmeschutz
- ▶ Lieferung im Etui ohne Einstellmaß

- ▶ DIN 863
- ▶ Comparator gauge DIN 879
- ▶ Micrometer reading 0.01mm
- ▶ Tungsten carbide-tipped measuring faces Ø8mm
- ▶ Spindle pitch 0.5mm
- ▶ Spindle clamping with lever
- ▶ Lifting device approx. 2.5mm with push button
- ▶ Constant measuring force, spring-loaded anvil
- ▶ Insulated pads
- ▶ Delivered in a case without setting gauge

**2018 2.. :**  
Ablesung Feinzeiger 0,001mm

**2018 2.. :**  
Reading comparator 0.001mm

**2018 1.. :**  
Ablesung Feinzeiger 0,002mm

**2018 1.. :**  
Reading comparator 0.002mm

**2037 1... :**  
Einstellmaße

**2037 1... :**  
Setting gauges

mm	mm	± μ	kg	Nº	Nº
0 - 25	0,001	70	0,7	2018 201	-
25 - 50	0,001	70	0,8	2018 202	2037 101
0 - 25	0,002	140	0,7	2018 101	-
25 - 50	0,002	140	0,8	2018 102	2037 101
50 - 75	0,002	140	0,9	2018 103	2037 102
75 - 100	0,002	140	1,0	2018 104	2037 103
100 - 125	0,002	140	1,2	2018 105	2037 104
125 - 150	0,002	140	1,4	2018 106	2037 105



No. 2018 201

Toleranzmarken einstellbar  
Tolerance marks adjustable



No. 2018 103

**Einbaumessschrauben Präzisionsausführung**

**Micrometer heads precision model**



Für unser komplettes Sortiment an Einbaumessschrauben fordern Sie bitte unsere separaten technischen Unterlagen an.

For our complete range of micrometer heads, please ask for separate technical documentation.

Wir liefern außerdem Sonderausführungen nach Ihren Zeichnungen.

In addition, we supply special versions according to your drawings.

**Auszug aus unserem Lieferprogramm:**

**Extract from our product range:**



No. 3585



No. 20711



No. 3130



No. 3530



No. 20715

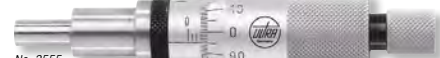

No. 3555



No. 3730



No. 3540



No. 3334

## Bügelmessschrauben mit Feinzeiger oder Messuhr

## External micrometers with comparator gauge or dial gauge



**Hartmetall**  
Tungsten carbide

- ▶ Genauigkeit besser als DIN 863
- ▶ Ablesung Mikrometer 0,005mm
- ▶ Hartmetallmessflächen Ø8mm
- ▶ Spindelsteigung 0,5mm
- ▶ Spindelklemmung mit Ring
- ▶ Anlüftung ca. 2,5mm, mit Hebel
- ▶ konstante Messkraft, federbelasteter Amboss
- ▶ Handwärmeschutz
- ▶ Lieferung im Etui ohne Einstellmaß und Feinzeiger/Messuhr

- ▶ Accuracy better than DIN 863
- ▶ Micrometer reading: 0.005mm
- ▶ Tungsten carbide-tipped measuring faces Ø8mm
- ▶ Spindle pitch 0.5mm
- ▶ Spindle clamping with ring
- ▶ Lifting device approx. 2.5mm, with lever
- ▶ Constant measuring force, spring-loaded anvil
- ▶ Insulated pads
- ▶ Delivered in a case without setting gauge and comparator gauge/dial gauge

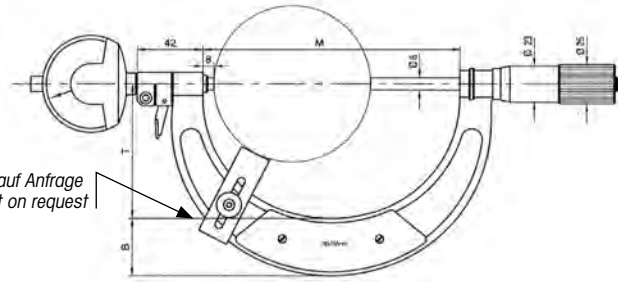

Zentrierstütze auf Anfrage  
Centre support on request



No. 2020 101

nicht im Lieferumfang  
not incl. in scope of delivery

2020 1.. :

Bügelmessschrauben

2020 1.. :

External micrometers

2037 1.. :

Einstellmaße

2037 1.. :

Setting gauges

µm mm	Δε mm	kg	Nº	Nº
0 – 25	0,005	0,6	2020 101	-
25 – 50	0,005	0,7	2020 102	2037 101
50 – 75	0,005	0,8	2020 103	2037 102
75 – 100	0,005	0,9	2020 104	2037 103
100 – 150	0,005	1,0	2020 105	2037 104
150 – 200	0,005	1,2	2020 106	2037 106
200 – 250	0,005	1,4	2020 107	2037 108
250 – 300	0,005	1,6	2020 108	2037 110
Messuhr 0,01mm / Dial gauge 0.01mm				1320 101
Feinzeiger 0,001mm / Comparator gauge 0.001mm				1308 202

## Bügelmessschrauben mit Messuhr

## External micrometers with dial gauge



**Hartmetall**  
Tungsten carbide

µm ≤6000mm

- ▶ DIN 863
- ▶ Ablesung Mikrometer 0,01mm, Messuhr 0,01mm
- ▶ Ableseteile mattverchromt
- ▶ Hartmetallmessflächen
- ▶ Spindelsteigung 1mm
- ▶ Spindelklemmung mit Hebel
- ▶ Rohrbügel mit Handwärmeschutz
- ▶ Lieferung einzeln verpackt, inkl. Messuhr, ohne Einstellmaße

- ▶ DIN 863
- ▶ Reading micrometers 0.01mm, dial gauge 0.01mm
- ▶ Safin chrome reading parts
- ▶ Tungsten carbide-tipped measuring faces
- ▶ Spindle pitch 1mm
- ▶ Spindle clamping with lever
- ▶ Pipe frame with insulated pads
- ▶ Delivered in individual packages, incl. dial gauge, without setting gauges

! Messbereich 2000 – 6000mm auf Anfrage.

! Measuring range 2000 – 6000mm on request.

! Kiste für Transport und Aufbewahrung auf Anfrage.

! Box for transport and storage on request.

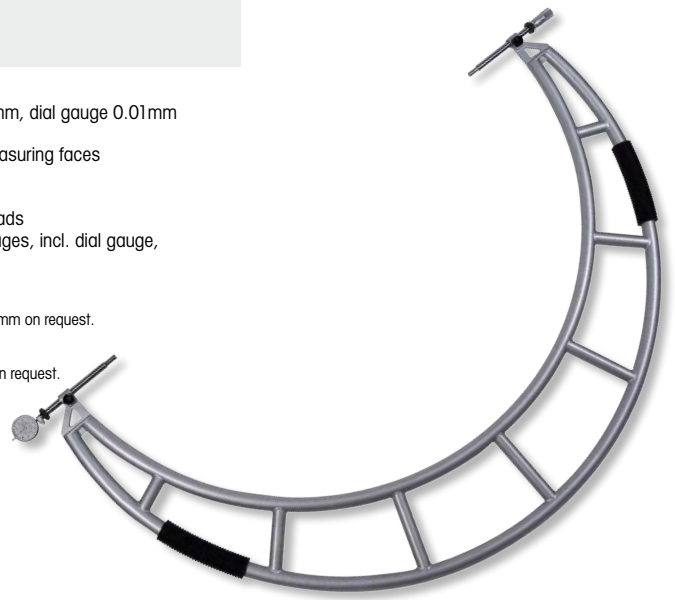

## Bügelmessschrauben mit Messuhr Amboss verschiebbar

## External micrometers with dial gauge with movable anvil



TOP



Hartmetall  
Tungsten carbide

||| ≤2000mm

- ▶ Genauigkeit besser als DIN 863
- ▶ Ablesung Mikrometer 0,01mm, Nonius 0,1mm
- ▶ Ableseteile mattverchromt
- ▶ Hartmetallmessflächen Ø 10mm
- ▶ Spindelsteigung 1,0mm
- ▶ Spindelklemmung mit Ring
- ▶ Leichtmetallbügel, mit Handwärmeschutz
- ▶ Anlüftung ca. 2,5mm, mit Hebel
- ▶ Konstante Messkraft, federbelasteter Amboss
- ▶ Lieferung einzeln verpackt ohne Messuhr

- ▶ Accuracy better than DIN 863
- ▶ Reading micrometer 0.01mm, vernier 0.1mm
- ▶ Satin chrome reading parts
- ▶ Tungsten carbide-tipped measuring faces Ø 10mm
- ▶ Spindle pitch 1.0mm
- ▶ Spindle clamping with ring
- ▶ Light metal frame with insulated pads
- ▶ Lifting device approx. 2.5mm, with lever
- ▶ Constant measuring force, spring-loaded anvil
- ▶ Delivered in individual packages without dial gauge



No. 2044 204

2044 2.. :

Bügelmessschrauben

2044 2.. :

External micrometers

2037 5.. :

Einstellmaße Satz (2 Stück)

2037 5.. :

Setting gauge sets (2 pieces)

2027 5.. :

Holzetuis

2027 5.. :

Wooden boxes



Ausführung mit Zubehör  
Model with accessories  
No. 2044 901, 2044 906, 1320 101

! Messbereiche bis 6000mm sowie andere Messflächenformen auf Anfrage.

! Measuring range up to 6000mm and other types of measuring faces on request.

mm	Δ mm	kg	Nº	Nº	Nº
200 – 300	0,01 / 0,1	1,7	2044 203	2037 503	2027 503
300 – 400	0,01 / 0,1	2,2	2044 204	2037 504	2027 504
400 – 500	0,01 / 0,1	2,7	2044 205	2037 505	2027 505
500 – 600	0,01 / 0,1	3,4	2044 206	2037 506	2027 506
600 – 700	0,01 / 0,1	4,0	2044 207	2037 507	2027 507
700 – 800	0,01 / 0,1	4,4	2044 208	2037 508	2027 508
800 – 900	0,01 / 0,1	5,3	2044 209	2037 509	2027 509
900 – 1000	0,01 / 0,1	6,4	2044 210	2037 510	2027 510
1000 – 1200	0,01 / 0,1	9,0	2044 211	2037 511	2027 511
1200 – 1400	0,01 / 0,1	11,2	2044 212	2037 512	2027 512
1400 – 1600	0,01 / 0,1	13,9	2044 213	2037 513	2027 513
1600 – 1800	0,01 / 0,1	16,5	2044 214	2037 514	2027 514
1800 – 2000	0,01 / 0,1	19,1	2044 215	2037 515	2027 515

> 2000mm auf Anfrage / > 2000mm on request

Zentrierstütze / Centre support	2044 901
Bohrungen in Messflächen Ø 4mm / Bores in measuring faces Ø 4mm	2044 905
Messteller Ø 35mm / Disc measuring faces Ø 35mm	2044 906
Messuhr / Dial gauge	1320 101

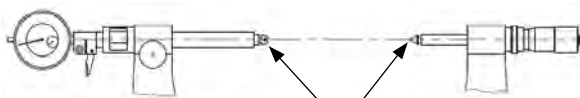

Bohrungen Ø4mm für  
Gewindeflankeneinsätze  
Bores Ø4mm for  
thread meas. inserts

No. 2044 905

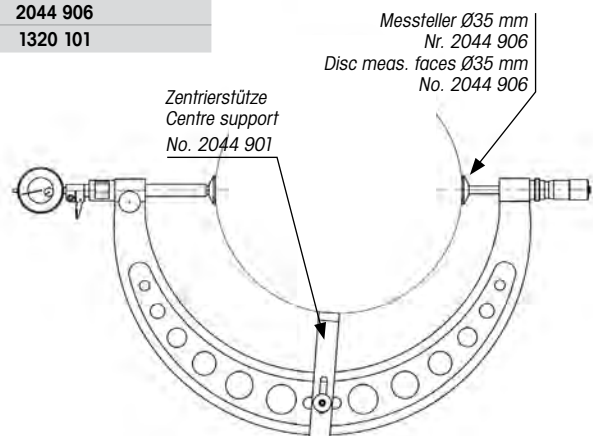

Messteller Ø35 mm  
Nr. 2044 906  
Disc meas. faces Ø35 mm  
No. 2044 906

Zentrierstütze  
Centre support  
No. 2044 901

## Bügelmessschrauben Präzisionsausführung External micrometers, precision model



- ▶ Genauigkeit besser als DIN 863
- ▶ Ableseteile mattverchromt
- ▶ Hartmetallmessflächen Ø8mm
- ▶ Spindelklemmung mit Ring
- ▶ vorgezogene Friktionskupplung
- ▶ Handwärmeschutz
- ▶ Lieferung im Etui ohne Einstellmaß

- ▶ Accuracy better than DIN 863
- ▶ Satin chrome reading parts
- ▶ Tungsten carbide-tipped measuring faces Ø8mm
- ▶ Spindle clamping with ring
- ▶ Pre-selected friction clutch
- ▶ Insulated pads
- ▶ Delivered in a case without setting gauge

**2029 1.. :**  
Spindelsteigung 0,5mm, Ablesung 0,01mm

**2029 1.. :**  
Spindle pitch 0.5mm, reading 0.01mm

**2029 2.. :**  
Spindelsteigung 1,0mm, Ablesung 0,01mm

**2029 2.. :**  
Spindle pitch 1.0mm, reading 0.01mm

**2029 3.. :**  
Spindelsteigung 0,5mm, Ablesung 0,005mm  
höchste Messgenauigkeit

**2029 3.. :**  
Spindle pitch 0.5mm, reading 0.005mm  
highest accuracy

**2037 1.. :**  
Einstellmaße

**2037 1.. :**  
Setting gauges

**!** Größere Messbereiche sowie andere  
Messflächenformen auf Anfrage.

**!** Larger measuring ranges and other  
types of measuring faces on request.

mm	kg	Nº	Nº	Nº	Nº
0 – 25	0,3	2029 101	2029 201	2029 301	-
25 – 50	0,4	2029 102	2029 202	2029 302	2037 101
50 – 75	0,45	2029 103	2029 203	2029 303	2037 102
75 – 100	0,55	2029 104	2029 204	2029 304	2037 103
100 – 125	0,6	2029 105	2029 205	2029 305	2037 104
125 – 150	0,7	2029 106	2029 206	2029 306	2037 105
150 – 175	0,8	2029 107	2029 207	2029 307	2037 106
175 – 200	0,95	2029 108	2029 208	2029 308	2037 107
200 – 225	1,05	2029 109	2029 209	2029 309	2037 108
225 – 250	1,2	2029 110	2029 210	2029 310	2037 109
250 – 275	1,3	2029 111	2029 211	2029 311	2037 110
275 – 300	1,4	2029 112	2029 212	2029 312	2037 111

> 300mm auf Anfrage / on request



## Bügelmessschrauben Präzisionsausführung 30mm Spindelverstellung External micrometers, precision model 30mm spindle adjustment



- ▶ Genauigkeit besser als DIN 863
- ▶ hervorstehender Amboss zum Messen bis in die Ecken
- ▶ Eckiger Bügel, ergonomisches Design, ideal zur Einhandmessung
- ▶ Ableseteile mattverchromt
- ▶ Spindelsteigung 1mm
- ▶ Hartmetallmessflächen Ø 8mm
- ▶ Spindelklemmung mit Hebel
- ▶ vorgezogene Friktionskupplung
- ▶ Handwärmeschutz
- ▶ Lieferung im Etui ohne Einstellmaß

- ▶ Accuracy better than DIN 863
- ▶ Protruding anvil to measure into corners
- ▶ Rectangular frame, ergonomic design, ideal for one hand use
- ▶ Satin chrome reading parts
- ▶ Spindle pitch 1mm
- ▶ Tungsten carbide-tipped measuring faces Ø 8mm
- ▶ Spindle clamping with lever
- ▶ Pre-selected friction clutch
- ▶ Insulated pads
- ▶ Delivered in a case without setting gauge

**2029 5.. :**  
Bügelmessschrauben

**2029 5.. :**  
External micrometers

**2037 1.. :**  
Einstellmaße

**2037 1.. :**  
Setting gauges

mm	mm	kg	Nº	Nº
0 – 30	0,01	0,32	2029 501	-
25 – 55	0,01	0,41	2029 502	2037 101
50 – 80	0,01	0,53	2029 503	2037 102
75 – 105	0,01	0,65	2029 504	2037 103



Überdeckende Messbereiche!  
Overlaying measuring ranges!

**Bügelmessschrauben Präzisionsausführung  
50mm Spindelverstellung**

**External micrometers, precision model  
spindle adjustment 50mm**



- ▶ Genauigkeit besser als DIN 863
- ▶ Ablesefeteile mattverchromt
- ▶ Spindelsteigung 1,0mm
- ▶ Hartmetallmessflächen Ø8mm
- ▶ Ablesung 0,01mm
- ▶ Spindelklemmung mit Ring
- ▶ Friktionskupplung
- ▶ Handwärmeschutz
- ▶ Lieferung im Etui ohne Einstellmaß

- ▶ Accuracy better than DIN 863
- ▶ Satin chrome reading parts
- ▶ Spindle pitch 1.0mm
- ▶ Tungsten carbide-tipped measuring faces Ø 8mm
- ▶ Reading 0.01mm
- ▶ Spindle clamping with ring
- ▶ Friction clutch
- ▶ Insulated pads
- ▶ Delivered in a case without setting gauge

**2035 1.. :**  
Bügelmessschrauben

**2035 1.. :**  
External micrometers

**2037 1.. :**  
Einstellmaße

**2037 1.. :**  
Setting gauges

mm	Δ mm	kg	Nº	Nº	Nº
0 – 50	0,01	0,45	2035 101	-	-
50 – 100	0,01	0,6	2035 102	2037 102	-
100 – 150	0,01	0,75	2035 103	2037 104	-
150 – 200	0,01	1,0	2035 104	2037 106	-
200 – 250	0,01	1,2	2035 105	2037 108	-
250 – 300	0,01	1,4	2035 106	2037 110	-



**Bügelmessschrauben Präzisionsausführung  
50mm Spindelverstellung**

**External micrometers, precision model  
spindle adjustment 50mm**



- ▶ Genauigkeit besser als DIN 863
- ▶ Ablesefeteile mattverchromt
- ▶ Spindelsteigung 1mm
- ▶ Hartmetallmessflächen Ø 10mm
- ▶ Ablesung 0,01mm
- ▶ Spindelklemmung mit Ring
- ▶ Friktionskupplung
- ▶ Leichtmetallbügel
- ▶ Lieferung einzeln verpackt; ohne Handwärmeschutz

- ▶ Accuracy better than DIN 863
- ▶ Satin chrome reading parts
- ▶ Spindle pitch 1mm
- ▶ Tungsten carbide-tipped measuring faces Ø 10mm
- ▶ Reading 0.01mm
- ▶ Spindle clamping with ring
- ▶ Friction clutch
- ▶ Light metal frame
- ▶ Delivered in individual packages; without insulated pads

**2035 1.. :**  
Bügelmessschrauben

**2035 1.. :**  
External micrometers

**2037 1.. :**  
Einstellmaße

**2037 1.. :**  
Setting gauges

**2036 1.. :**  
Holzetuis

**2036 1.. :**  
Wooden boxes

! Größere Messbereiche sowie andere Messflächenformen auf Anfrage.

! Larger measuring ranges and other types of measuring faces on request.





mm	Δ mm	kg	Nº	Nº	Nº
300 – 350	0,01	1,5	2035 107	2037 112	2036 107
350 – 400	0,01	1,8	2035 108	2037 114	2036 108
400 – 450	0,01	2,15	2035 109	2037 116	2036 109
450 – 500	0,01	2,3	2035 110	2037 118	2036 110
500 – 550	0,01	2,4	2035 111	2037 120	2036 111
550 – 600	0,01	3,0	2035 112	2037 121	2036 112

> 600mm auf Anfrage / on request  
Handwärmeschutz / Insulated pads



**Bügelmessschrauben Präzisionsausführung**  
**50mm Spindelverstellung / Messweg 100mm**

**External micrometers, precision model**  
**spindle adjustment 50 mm / measuring span 100 mm**





**≤2000mm**

- ▶ Genauigkeit besser als DIN 863
- ▶ Endmaßverlängerung 50mm aufschraubbar
- ▶ Ablese Teile mattverchromt
- ▶ Hartmetallmessflächen Ø 10mm
- ▶ Spindelsteigung 1mm
- ▶ Spindelklemmung mit Ring
- ▶ Friktionskupplung
- ▶ Leichtmetallbügel
- ▶ Lieferung einzeln verpackt, inkl. Verlängerung 50mm (Nr. 2039 901)

- ▶ Accuracy better than DIN 863
- ▶ Screwable extensions 50mm
- ▶ Satin chrome reading parts
- ▶ Tungsten carbide-tipped measuring faces Ø 10mm
- ▶ Spindle pitch 1mm
- ▶ Spindle clamping with ring
- ▶ Friction clutch
- ▶ Light metal frame
- ▶ Delivered in individual packages, incl. extension 50mm (No. 2039 901)



No. 2039 203

<b>2039 2.. :</b> Mikrometer	<b>2039 2.. :</b> Micrometers
<b>2037 1.. :</b> Einstellmaße	<b>2037 1.. :</b> Setting gauges
<b>2027 9.. :</b> Holzetuis	<b>2027 9.. :</b> Wooden boxes

**I** Wesentlich einfacheres Handling und größere Messsicherheit als bei Modellen mit austauschbaren Einsätzen.

**I** Considerably easier handling and much better measuring security than models with interchangeable inserts.

mm	mm	kg	Nº	Nº	Nº
200 – 300	0,01	1,5	2039 201	2037 110	2027 901
300 – 400	0,01	1,9	2039 202	2037 114	2027 902
400 – 500	0,01	2,4	2039 203	2037 118	2027 903
500 – 600	0,01	3,1	2039 204	2037 122	2027 904
600 – 700	0,01	3,8	2039 205	2037 126	2027 905
700 – 800	0,01	4,2	2039 206	2037 130	2027 906
800 – 900	0,01	5,0	2039 207	2037 134	2027 907
900 – 1000	0,01	6,2	2039 208	2037 138	2027 908
1000 – 1100	0,01	7,6	2039 209	2037 142	2027 909
1100 – 1200	0,01	8,6	2039 210	2037 146	2027 910
1200 – 1300	0,01	9,7	2039 211	2037 150	2027 911
1300 – 1400	0,01	11,3	2039 212	2037 154	2027 912
1400 – 1500	0,01	12,5	2039 213	2037 158	2027 913
1500 – 1600	0,01	13,6	2039 214	2037 162	2027 914
1600 – 1700	0,01	14,9	2039 215	2037 166	2027 915
1700 – 1800	0,01	16,2	2039 216	2037 170	2027 916
1800 – 1900	0,01	17,5	2039 217	2037 174	2027 917
1900 – 2000	0,01	18,8	2039 218	2037 178	2027 918

Zentrierstütze / Centre support	2044 901
Handwärmeschutz / Insulated pads	2035 901
Endmaßverlängerung / Extension 100mm	2039 902
Endmaßverlängerung / Extension 150mm	2039 903



Option: Handwärmeschutz  
 Option: Insulated pads  
 No. 2035 901

Mit den zusätzlichen Endmaßverlängerungen kann der Messbereich um 50/100mm nach unten erweitert werden.

With the additional extensions the measuring range will be extended by 50/100mm to a lower range.



No. 2039 902



No. 2039 903



**Bügelmessschrauben, Amboss verschiebbar  
50mm Spindelverstellung**

**External micrometers with movable anvil  
spindle adjustment 50mm**

  **Hartmetall Tungsten carbide**  $\mu\text{m} \leq 2000\text{mm}$

- ▶ Genauigkeit besser als DIN 863
- ▶ Ablesung Mikrometer 0,01mm, Nonius 0,1mm
- ▶ Ablese Teile mattverchromt
- ▶ Hartmetallmessflächen Ø 10mm
- ▶ Spindelsteigung 1,0mm
- ▶ Spindelklemmung mit Ring
- ▶ Friktionskupplung
- ▶ Leichtmetallbügel
- ▶ Lieferung einzeln verpackt

- ▶ Accuracy better than DIN 863
- ▶ Reading micrometer 0.01mm, vernier 0.1 mm
- ▶ Satin chrome reading parts
- ▶ Tungsten carbide-tipped measuring faces Ø 10mm
- ▶ Spindle pitch 1.0mm
- ▶ Spindle clamping with ring
- ▶ Friction clutch
- ▶ Light metal frame
- ▶ Delivered in individual packages

**2043 2.. :**

Bügelmessschrauben

**2043 2.. :**

External micrometers

**2037 4.. :**

Einstellmaße Satz (3 Stück)

**2037 4.. :**

Setting gauge set (3 pieces)

**2027 4.. :**

Holzetuis

**2027 4.. :**

Wooden boxes

**!** Andere Messflächenformen auf Anfrage.

**!** Other types of measuring faces on request.

$\mu\text{m}$ mm	$\leq$ mm	$\bar{m}$ kg	Nº	Nº	Nº
0 – 300	0,01 / 0,1	1,9	2043 201	2037 401	2027 401
300 – 600	0,01 / 0,1	3,5	2043 202	2037 402	2027 402
600 – 900	0,01 / 0,1	5,4	2043 203	2037 403	2027 403
900 – 1200	0,01 / 0,1	9,0	2043 204	2037 404	2027 404
1200 – 1500	0,01 / 0,1	12,9	2043 205	2037 405	2027 405
1500 – 1800	0,01 / 0,1	16,6	2043 206	2037 406	2027 406
1700 – 2000	0,01 / 0,1	19,2	2043 207	2037 407	2027 407
Zentrierstütze / Centre support				2044 901	
Handwärmeschutz / Insulated pads				2035 901	



Option: Handwärmeschutz  
Option: Insulated pads  
No. 2035 901



**Bügelmessschrauben, Amboss auswechselbar  
25mm Spindelverstellung / Messweg 150mm**

**External micrometers, interchangeable anvils  
spindle adjustment 25mm / measuring span 150mm**

  **Hartmetall Tungsten carbide**  $\mu\text{m} \leq 2950\text{mm}$

- ▶ DIN 863
- ▶ Ablese Teile mattverchromt
- ▶ Hartmetallmessflächen Ø 8mm
- ▶ Spindelsteigung 1mm
- ▶ Spindelklemmung mit Hebel
- ▶ Gefühlsratsche
- ▶ Rohrbügel mit Handwärmeschutz
- ▶ Lieferung einzeln verpackt, inkl. 6 Ambosse und Einstellmaße

- ▶ DIN 863
- ▶ Satin chrome reading parts
- ▶ Tungsten carbide-tipped measuring faces Ø 8mm
- ▶ Spindle pitch 1mm
- ▶ Spindle clamping with lever
- ▶ Ratchet stop
- ▶ Pipe frame with insulated pads
- ▶ Delivered in individual packages, incl. 6 anvils and setting gauges

**!** Kiste für Transport und Aufbewahrung auf Anfrage.

**!** Box for transport and storage on request.

$\mu\text{m}$ mm	$\leq$ mm	$\bar{m}$ kg	Nº	$\mu\text{m}$ mm	$\leq$ mm	$\bar{m}$ kg	Nº
1900 – 2050	0,01	20,0	2041 101	2500 – 2650	0,01	37,0	2041 105
2050 – 2200	0,01	24,0	2041 102	2650 – 2800	0,01	40,0	2041 106
2200 – 2350	0,01	27,0	2041 103	2800 – 2950	0,01	42,0	2041 107
2350 – 2500	0,01	30,0	2041 104				

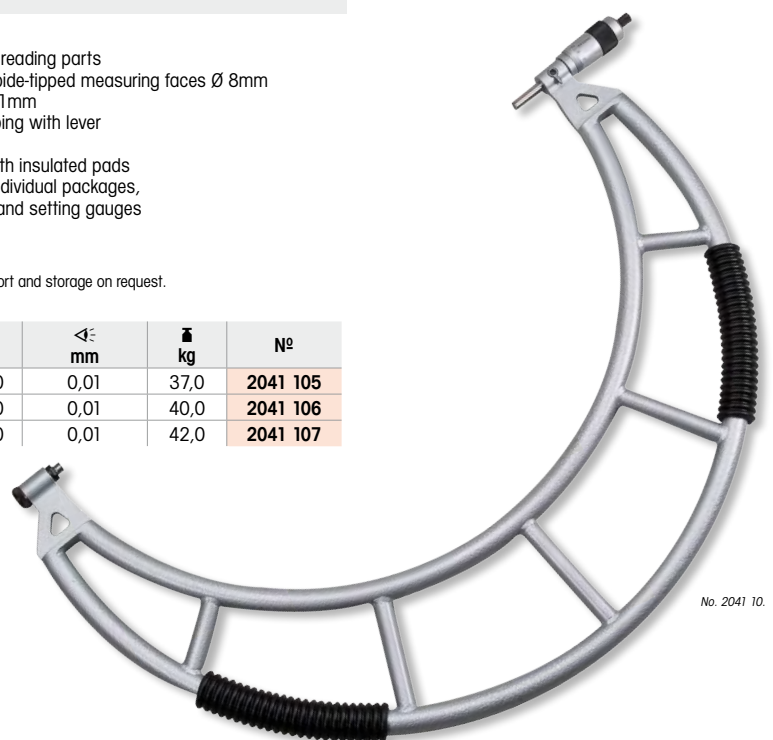

## Bügelmessschrauben STANDARD

## External micrometers STANDARD



**Hartmetall  
Tungsten carbide**

- ▶ DIN 863
- ▶ Spindelsteigung 1,0mm
- ▶ Ablese Teile mattverchromt
- ▶ Hartmetallmessflächen Ø8mm
- ▶ Spindelklemmung mit Hebel
- ▶ Gefühlsratsche
- ▶ Handwärmeschutz
- ▶ Lieferung im Etui ab 25 – 50mm mit Einstellmaß

- ▶ DIN 863
- ▶ Spindle pitch 1.0mm
- ▶ Satin chrome reading parts
- ▶ Tungsten carbide-tipped measuring faces Ø8mm
- ▶ Spindle clamping with lever
- ▶ Ratchet stop
- ▶ Insulated pads
- ▶ Delivered in a case; from 25 – 50mm with setting gauge



l mm	<math>\Delta</math> mm	m kg	Nº
0 – 25	0,01	0,45	5004 501
25 – 50	0,01	0,6	5004 502
50 – 75	0,01	0,7	5004 503
75 – 100	0,01	0,8	5004 504

## Bügelmessschrauben STANDARD

## External micrometers STANDARD



**Hartmetall  
Tungsten carbide**

- ▶ DIN 863
- ▶ Spindelsteigung 0,5mm
- ▶ Ablese Teile mattverchromt
- ▶ Hartmetallmessflächen Ø6,5mm
- ▶ Spindelklemmung mit Hebel
- ▶ vorgezogene Gefühlsratsche
- ▶ Handwärmeschutz
- ▶ Lieferung im Etui ab 25 – 50mm mit Einstellmaß

- ▶ DIN 863
- ▶ Spindle pitch 0.5mm
- ▶ Satin chrome reading parts
- ▶ Tungsten carbide-tipped measuring faces Ø6.5mm
- ▶ Spindle clamping with lever
- ▶ Ratchet stop on thimble
- ▶ Insulated pads
- ▶ Delivered in a case; from 25 – 50mm with setting gauge



l mm	<math>\Delta</math> mm	m kg	Nº
0 – 25	0,01	0,35	2031 201
25 – 50	0,01	0,45	2031 202
50 – 75	0,01	0,6	2031 203
75 – 100	0,01	0,65	2031 204

Satz im Holzetui: / Set in wooden box:

0 – 100	0,01	2,5	2031 301
---------	------	-----	----------



## Messmittelhalter für Bügelmessschrauben

## Measuring equipment holder for external micrometers



- ▶ Klemmeinrichtung schwenkbar
- ▶ Lieferung einzeln verpackt

- ▶ Pivoting clamping device
- ▶ Delivered in individual packages

**2038 100 :**

Stahlbügel

**2038 100 :**

Steel frame

**2038 101 :**

schwerer Gussfuß

**2038 101 :**

Heavy cast iron base

für / for l mm	Spannbereich / clamping range mm	l mm	m kg	Nº
≤ 100	15	117x100x35	1,0	2038 100
≤ 300	20	130x100x90	1,5	2038 101



## Kraftmessgerät für Bügelmessschrauben

## Force measuring device for external micrometers



- ▶ zur Prüfung der Messkraft 5 – 12 N
- ▶ min / max Markierung
- ▶ Lieferung inkl. Verlängerungen 25/50/75mm im Etui

- ▶ For checking the measuring force of micrometers 5 – 12 N
- ▶ Min/max marking
- ▶ Delivered incl. extensions 25/50/75mm in a case

l mm	Ø mm	m kg	Nº
≤ 100	≤ 8	0,02	2038 201



## Bügelmessschrauben STANDARD

## External micrometers STANDARD



- ▶ DIN 863
- ▶ Spindelsteigung 0,5mm
- ▶ Ablese Teile mattverchromt
- ▶ Hartmetallmessflächen Ø6,5mm
- ▶ Spindelklemmung mit Hebel
- ▶ Gefühlsratsche
- ▶ Handwärmeschutz
- ▶ Lieferung im Etui ab 25 – 50mm mit Einstellmaß

- ▶ DIN 863
- ▶ Spindle pitch 0.5mm
- ▶ Satin chrome reading parts
- ▶ Tungsten carbide-tipped measuring faces Ø 6.5mm
- ▶ Spindle clamping with lever
- ▶ Ratchet stop
- ▶ Insulated pads
- ▶ Delivered in a case; from 25 – 50mm with setting gauge

**5004 1.. / 5004 2..:**  
Bügel mattverchromt

**5004 1.. / 5004 2..:**  
Satin chrome frame

**5005 2..:**  
Bügel lackiert

**5005 2..:**  
Lacquered frame



mm	≤ mm	kg	Nº
0 – 25	0,01	0,35	5004 101
25 – 50	0,01	0,45	5004 102
50 – 75	0,01	0,6	5004 103
75 – 100	0,01	0,8	5004 104
100 – 125	0,01	0,98	5004 105
125 – 150	0,01	1,15	5004 106
150 – 175	0,01	1,4	5004 107
175 – 200	0,01	1,7	5004 108
200 – 225	0,01	1,95	5005 209
225 – 250	0,01	2,15	5005 210
250 – 275	0,01	2,4	5005 211
275 – 300	0,01	2,57	5005 212
Satz im Holzetui: / Set in wooden box:			
0 – 100	0,01	2,5	5004 201
0 – 150	0,01	3,5	5004 202

## Bügelmessschrauben STANDARD mit auswechselbaren Einsätzen

## External micrometers, STANDARD with interchangeable inserts



- ▶ DIN 863
- ▶ Ablese Teile mattverchromt
- ▶ Hartmetallmessflächen
- ▶ Spindelsteigung 0,5mm
- ▶ Spindelklemmung mit Hebel
- ▶ Gefühlsratsche
- ▶ Lieferung im Etui mit Einstellmaßen

- ▶ DIN 863
- ▶ Satin chrome reading parts
- ▶ Tungsten carbide-tipped measuring faces
- ▶ Spindle pitch 0.5mm
- ▶ Spindle clamping with lever
- ▶ Ratchet stop
- ▶ Delivered in a case with setting gauges

**5013 201 – 5013 204 :**  
Stahlbügel,  
Hartmetallmessflächen Ø 6,5mm

**5013 201 – 5013 204 :**  
Steel frame,  
Tungsten carbide-tipped measuring faces Ø 6.5mm

**5013 205 – 5013 216 :**  
Rohrbügel mit Handwärmeschutz,  
Hartmetallmessflächen Ø 8.0mm

**5013 205 – 5013 216 :**  
Pipe frame, with insulated pads  
Tungsten carbide-tipped measuring faces Ø 8.0mm

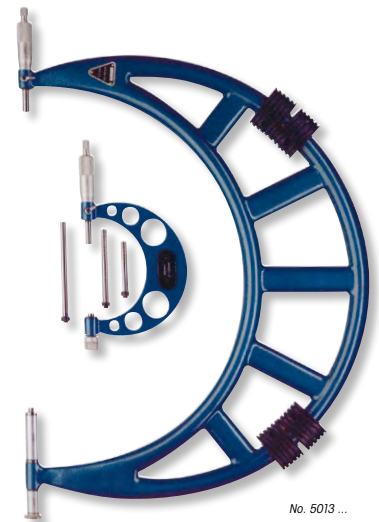

mm	≤ mm	kg	Nº	mm	≤ mm	kg	Nº
0 – 100	0,01	1,1	5013 201	700 – 800	0,01	14,0	5013 209
0 – 150	0,01	1,4	5013 202	800 – 900	0,01	16,5	5013 210
100 – 200	0,01	2,1	5013 203	900 – 1000	0,01	20,0	5013 211
200 – 300	0,01	3,4	5013 204	1000 – 1200	0,01	29,0	5013 212
300 – 400	0,01	5,7	5013 205	1200 – 1400	0,01	33,0	5013 213
400 – 500	0,01	7,2	5013 206	1400 – 1600	0,01	40,0	5013 214
500 – 600	0,01	9,5	5013 207	1600 – 1800	0,01	50,0	5013 215
600 – 700	0,01	10,5	5013 208	1800 – 2000	0,01	60,0	5013 216

## Einstellmaße für Bügelmessschrauben

## Setting gauges for external micrometers



**Gehärtet  
Hardened**

- ▶ Genauigkeit nach DIN 863 (js2), ab 200mm besser als DIN
- ▶ Spezialstahl gehärtet
- ▶ Messflächen plan
- ▶ Parallelität < 1µ
- ▶ Handwärmeschutz
- ▶ Lieferung einzeln verpackt

- ▶ Accuracy according DIN 863 (js2), from 200mm better than DIN
- ▶ Hardened special steel
- ▶ Measuring faces plane
- ▶ Parallelism < 1µ
- ▶ Insulated pads
- ▶ Delivered in individual packages

**2037 101 – 2037 111 :**  
Messflächen Ø 6,5mm

**2037 101 – 2037 111 :**  
Measuring faces Ø 6.5mm

**2037 112 – 2037 178 :**  
Messflächen Ø 10mm

**2037 112 – 2037 178 :**  
Measuring faces Ø 10mm

! Andere Abmessungen sowie Sonderlängen auf Anfrage.

! Other dimensions and special lengths on request.

! Endmaßsätze zur Prüfung von  
Messschrauben siehe Produktgruppe 1.

! Gauge block sets for testing  
micrometers, see product group 1.

l-l mm	± kg	Nº
25	0,02	2037 101
50	0,02	2037 102
75	0,04	2037 103
100	0,05	2037 104
125	0,07	2037 105
150	0,08	2037 106
175	0,09	2037 107
200	0,11	2037 108
225	0,12	2037 109
250	0,13	2037 110
275	0,15	2037 111
300	0,34	2037 112
325	0,37	2037 113
350	0,39	2037 114
375	0,42	2037 115
400	0,44	2037 116
425	0,47	2037 117
450	0,49	2037 118
475	0,52	2037 119
500	0,54	2037 120
525	0,57	2037 121
550	0,6	2037 122
575	0,62	2037 123
600	0,65	2037 124
625	0,67	2037 125

l-l mm	± kg	Nº
650	0,7	2037 126
675	0,73	2037 127
700	0,76	2037 128
725	0,79	2037 129
750	0,82	2037 130
775	0,85	2037 131
800	0,87	2037 132
825	0,9	2037 133
850	0,92	2037 134
875	0,94	2037 135
900	0,97	2037 136
925	1,0	2037 137
950	1,01	2037 138
975	1,04	2037 139
1000	1,06	2037 140
1050	1,12	2037 142
1150	1,22	2037 146
1250	1,33	2037 150
1350	1,42	2037 154
1450	1,75	2037 158
1550	1,88	2037 162
1650	2,0	2037 166
1750	2,12	2037 170
1850	2,24	2037 174
1950	2,36	2037 178



## Prüfglas-Sätze

## Optical parallel sets



- ▶ zur Prüfung der Ebenheit und Parallelität der Messflächen an Bügelmessschrauben
- ▶ Lieferung im Etui

- ▶ For checking flatness and parallelism of measuring faces of external micrometers
- ▶ Delivered in a case

l-l mm	für / for l-l mm	Ø mm	∠ µ	// µ	Nº
12,00 / 12,12 12,25 / 12,37	0 – 25	31	0,15	0,3	1050 201
27,0 / 27,16 27,33	25 – 50	31	0,15	0,4	1050 202
52,00 / 52,16 52,33	50 – 75	31	0,2	0,5	1050 203
77,00 / 77,16 77,33	75 – 100	31	0,2	0,5	1050 204



Prüfung der Messflächen nach dem Interferenzverfahren.  
Controlling of the measuring faces acc. to the interference method.

## Bügelmessschrauben für Außengewindemessung

## External micrometers for thread measurements



- ▶ Genauigkeit besser als DIN 863
- ▶ Ablesefläche mattverchromt
- ▶ Spindelsteigung 0,5mm (1,0mm auf Anfrage)
- ▶ Spindelklemmung mit Ring
- ▶ Friktionskupplung
- ▶ Lieferung im Etui ohne Einsätze

- ▶ Accuracy better than DIN 863
- ▶ Satin chrome reading parts
- ▶ Spindle pitch 0.5mm (1.0mm on request)
- ▶ Spindle clamping with ring
- ▶ Friction clutch
- ▶ Delivered in a case without inserts

**2045 1.. :**

Bügelmessschraube

**2045 1.. :**

External micrometers

**2047 1.. :**

Einstellmaße 60° metrisch, gehärtet

**2047 1.. :**

Setting gauges 60° metric, hardened

**2047 2.. :**

Einstellmaße 55° Whitworth, gehärtet

**2047 2.. :**

Setting gauges 55° Whitworth, hardened

**2047 3.. :**

Einstellmaße 30° Trapez, gehärtet.

Bei Trapezgewinde ist für jede Steigung ein separates Einstellmaß erforderlich. Bitte benötigte Steigung angeben.

**2047 3.. :**

Setting gauges 30° Trapezoidal, hardened.

For trapezoidal thread, a separate setting gauge is required for each pitch. Please specify required pitch.

! Flankeneinsätze bitte separat bestellen.

! Please order thread inserts separately.

∅ mm	<= mm	kg	Nº	Nº	Nº	Nº
0 – 25	0,01	0,29	2045 101	-	-	-
25 – 50	0,01	0,36	2045 102	2047 101	2047 201	2047 301
50 – 75	0,01	0,43	2045 103	2047 102	2047 202	2047 302
75 – 100	0,01	0,52	2045 104	2047 103	2047 203	2047 303
100 – 125	0,01	0,6	2045 105	2047 104	2047 204	2047 304
125 – 150	0,01	0,7	2045 106	2047 105	2047 205	2047 305
150 – 200	0,01	1,0	2045 107	2047 106	2047 206	2047 306
200 – 250	0,01	1,2	2045 108	2047 107	2047 207	2047 307
250 – 300	0,01	1,4	2045 109	2047 108	2047 208	2047 308

> 300mm auf Anfrage / > 300mm on request

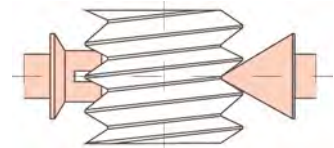

## Gewindeflankeneinsätze, Paar für Außenmessung

## Thread inserts, pair for outside measurements

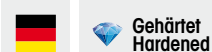

- ▶ Spezialstahl gehärtet
- ▶ Ø 4x15,5mm
- ▶ mit Steigung beschriftet
- ▶ Lieferung paarweise verpackt

- ▶ Hardened special steel
- ▶ Ø 4x15.5mm
- ▶ Marked pitch
- ▶ Delivered in a package (pair)

**2048 1.. :**

60° metrisch, UNC, UNF

**2048 1.. :**

60° Metric, UNC, UNF

**2049 1.. :**

55° Whitworth

**2049 1.. :**

55° Whitworth

**2049 2.. :**

30° Trapez DIN 103

**2049 2.. :**

30° Trapezoidal DIN 103

! Einsätze für andere Fabrikate auf Anfrage.

! Inserts for other brands on request.

Steigung / Pitch mm	UNC, UNF	60° Nº	Gang / Zoll Thread / inch	55° Nº	Steigung / Pitch mm	30° Nº
0,35 – 0,5	72 – 48	2048 101	60 – 48	2049 101	1,5	2049 201
0,6 – 0,8	44 – 32	2048 102	40 – 32	2049 103	2	2049 202
0,9 – 1,25	28 – 18	2048 103	28 – 22	2049 104	3	2049 203
1,5 – 2,0	16 – 11	2048 104	20 – 16	2049 106	4	2049 204
2,5 – 3,5	10 – 7	2048 105	14 – 11	2049 107	5 – 6	2049 205
4 – 6	6 – 4	2048 106	10 – 7	2049 108	7 – 8	2049 206
-	-	-	6 – 4	2049 109	9 – 10	2049 207
-	-	-	-	-	12 – 14	2049 208



## Digital-Bügelmessschrauben für Außengewindemessung

## Digital external micrometer for thread measurements



- ▶ DIN 863
- ▶ Sylvac System
- ▶ großes LCD Display
- ▶ nichtdrehende Spindel
- ▶ Spindelsteigung 1mm
- ▶ Messkraft 5 – 10 N
- ▶ Handwärmeschutz
- ▶ Lieferung im Etui ohne Einsätze

### Funktionen:

- ▶ Ein/Aus, mm/inch Umschaltung, 0-Punkt an jeder Position, Ablesung umschaltbar 0,01/0,001mm, Preset Funktion, Toleranzwerteingabe, Hold Funktion, Datenausgang Opto

### 2045 151 – 2045 162:

Geführtsratsche, Spindelklemmung mit Hebel

### 2045 171 – 2045 182:

mit Anlüftung ca. 2mm, mit Hebel konstante Messkraft durch federbelastete Spindel

### 2047 1..:

Einstellmaße 60° metrisch, gehärtet

### 2047 2..:

Einstellmaße 55° Whitworth, gehärtet

**I** Größere Messbereiche auf Anfrage.

- ▶ DIN 863
- ▶ Sylvac System
- ▶ Large LCD display
- ▶ Non-turning spindle
- ▶ Spindle pitch 1mm
- ▶ Measuring force 5 – 10 N
- ▶ Insulated pads
- ▶ Delivered in a case without inserts

### Funktionen:

- ▶ On/Off, mm/inch commutation, Zero setting at any position, Reversible reading 0.01/0.001mm, Preset function, Tolerance input, Hold function, Data output Opto

### 2045 151 – 2045 162:

Ratchet stop, spindle clamping with lever

### 2045 171 – 2045 182:

With lifting device approx. 2mm, with lever constant measuring force through spring-loaded spindle

### 2047 1..:

Setting gauges 60° metric, hardened

### 2047 2..:

Setting gauges 55° Whitworth, hardened

**I** Larger measuring ranges on request.



No. 2045 15.

Einsätze bitte separat bestellen.  
Please order thread inserts separately.



No. 2047 102

No. 2047 202

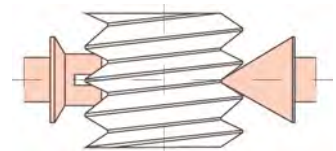

mm $\frac{mm}{inc}$	inc approx.	$\leq$ mm / inch	$\bar{m}$ kg	Nº	Nº	Nº	Nº
0 – 25	0 – 1	0,01 / .0005 0,001 / .00005	0,4	2045 151	2045 171	-	-
25 – 50	1 – 2	0,01 / .0005 0,001 / .00005	0,5	2045 152	2045 172	2047 101	2047 201
50 – 75	2 – 3	0,01 / .0005 0,001 / .00005	0,6	2045 153	2045 173	2047 102	2047 202
75 – 100	3 – 4	0,01 / .0005 0,001 / .00005	0,7	2045 154	2045 174	2047 103	2047 203
100 – 125	4 – 5	0,01 / .0005 0,001 / .00005	0,7	2045 155	2045 175	2047 104	2047 204
125 – 150	5 – 6	0,01 / .0005 0,001 / .00005	0,9	2045 156	2045 176	2047 105	2047 205
150 – 175	6 – 7	0,01 / .0005 0,001 / .00005	1,0	2045 157	2045 177	2047 106	2047 206

mm $\frac{mm}{inc}$	inc approx.	$\leq$ mm / inch	$\bar{m}$ kg	Nº	Nº	Nº	Nº
175 – 200	7 – 8	0,01 / .0005 0,001 / .00005	1,2	2045 158	2045 178	2047 106	2047 206
200 – 225	8 – 9	0,01 / .0005 0,001 / .00005	1,3	2045 159	2045 179	2047 107	2047 207
225 – 250	9 – 10	0,01 / .0005 0,001 / .00005	1,5	2045 160	2045 180	2047 107	2047 207
250 – 275	10 – 11	0,01 / .0005 0,001 / .00005	1,6	2045 161	2045 181	2047 108	2047 208
275 – 300	11 – 12	0,01 / .0005 0,001 / .00005	1,7	2045 162	2045 182	2047 108	2047 208
> 300mm auf Anfrage / on request							
Datenkabel RS232 (2m) / Data cable RS232 (2m)						1850 203	
Datenkabel USB (2m) / Data cable USB (2m)						1850 204	

## Gewindeflankeneinsätze, Paar für Außenmessung

## Thread inserts, pair for outside measurements



- ▶ Spezialstahl, gehärtet
- ▶ Ø 3,5x13,5mm
- ▶ mit Steigung beschriftet
- ▶ Lieferung paarweise verpackt

### 2048 151 – 2048 164 :

60° metrisch

### 2049 151 – 2049 162 :

55° Whitworth

- ▶ Hardened special steel
- ▶ Ø 3.5x13.5mm
- ▶ Marked pitch
- ▶ Delivered in a package (pair)

### 2048 151 – 2048 164 :

60° Metric

### 2049 151 – 2049 162 :

55° Whitworth



No. 2048 160

Steigung / Pitch mm	60° Nº	Steigung / Pitch mm	60° Nº	Gang / Zoll Thread / inch	55° Nº	Gang / Zoll Thread / inch	55° Nº
0,2	2048 151	0,7 – 0,8	2048 158	80	2049 151	10 – 8	2049 158
0,225	2048 152	1 – 1,25	2048 159	72 – 64	2049 152	7 – 6	2049 159
0,25	2048 153	1,5 – 1,75	2048 160	60 – 48	2049 153	5 – 4	2049 160
0,3	2048 154	2 – 2,5	2048 161	40 – 32	2049 154	3,5 – 2,75	2049 161
0,35	2048 155	3 – 3,5	2048 162	28 – 22	2049 155	2,625 – 2	2049 162
0,4 – 0,45	2048 156	4 – 5	2048 163	20 – 16	2049 156	-	-
0,5 – 0,6	2048 157	5,5 – 6	2048 164	14 – 11	2049 157	-	-

**Innenmessschrauben  
für Gewindemessung**

**Internal micrometers  
for thread measurements**



- ▶ DIN 863
- ▶ Ableseföhrte mattverchromt
- ▶ Spindelsteigung 0,5mm
- ▶ Spindelklemmung
- ▶ Lieferung im Etui ohne Einsätze

- ▶ DIN 863
- ▶ Satin chrome reading parts
- ▶ Spindle pitch 0.5mm
- ▶ Spindle clamping
- ▶ Ratchet stop
- ▶ Delivered in a case without inserts

**2074 101 – 104 :**  
Schnabeltype, parallaxfreie Ablesung, mit Geföhlsratsche

**2074 101 – 104 :**  
Jaw type, parallax free reading, with ratchet stop

**2074 105 – 112 :**  
zylindrische Typen, ohne Geföhlsratsche

**2074 105 – 112 :**  
Cylindrical type, without ratchet stop

**!** Flankeneinsätze bitte separat bestellen.

**!** Please order thread inserts separately.

mm	<math>\leq</math> mm	kg	Nº
20 – 45	0,01	0,26	2074 101
45 – 70	0,01	0,27	2074 102
70 – 95	0,01	0,29	2074 103
95 – 120	0,01	0,34	2074 104
100 – 125	0,01	0,12	2074 105
125 – 150	0,01	0,16	2074 106
150 – 175	0,01	0,18	2074 107
175 – 200	0,01	0,19	2074 108
200 – 225	0,01	0,26	2074 109
225 – 250	0,01	0,28	2074 110
250 – 275	0,01	0,3	2074 111
275 – 300	0,01	0,32	2074 112

Einsätze bitte separat bestellen.  
Please order thread insert separately.

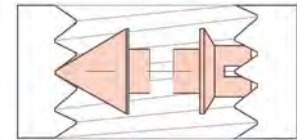

**Gewindeflankeneinsätze, Paar  
für Innenmessung**

**Thread inserts, pair  
for inside measurements**



**Gehärtet  
Hardened**

- ▶ Spezialstahl gehärtet
- ▶ Ø 3,5 x 5mm für Schnabeltyp
- ▶ Ø 3,5 x 13,5mm für zyl. Form
- ▶ mit Steigung beschriftet
- ▶ Lieferung paarweise verpackt

- ▶ Hardened special steel
- ▶ Ø 3.5 x 5mm for jaw type
- ▶ Ø 3.5 x 13.5mm for cylindrical type
- ▶ Marked pitch
- ▶ Delivered in a package (pair)

**2074 3.. :**  
60° metrisch  
für Schnabeltype Nr. 2074 101 – 2074 104

**2074 3.. :**  
60° Metric  
for jaw types No. 2074 101 – 2074 104

**2074 3..L :**  
60° metrisch  
für zylindrische Typen Nr. 2074 105 – 2074 112

**2074 3..L :**  
60° Metric  
for cylindrical types No. 2074 105 – 2074 112

**2074 4.. :**  
55° Whitworth  
für Schnabeltype Nr. 2074 101 – 2074 104

**2074 4.. :**  
55° Whitworth  
for jaw types No. 2074 101 – 2074 104

**2074 4..L :**  
55° Whitworth  
für zylindrische Typen Nr. 2074 105 – 2074 112

**2074 4..L :**  
55° Whitworth  
for cylindrical types No. 2074 105 – 2074 112

Steigung / Pitch mm	60°		Gang / Zoll Thread / inch	55°	
	Nº	Nº		Nº	Nº
0,35	2074 301	2074 301L	60 – 48	2074 401	2074 401L
0,4 – 0,45	2074 302	2074 302L	40 – 32	2074 402	2074 402L
0,5 – 0,6	2074 303	2074 303L	28 – 22	2074 403	2074 403L
0,7 – 0,8	2074 304	2074 304L	20 – 16	2074 404	2074 404L
1,0 – 1,25	2074 305	2074 305L	14 – 11	2074 405	2074 405L
1,5 – 1,75	2074 306	2074 306L	10 – 8	2074 406	2074 406L
2,0 – 2,5	2074 307	2074 307L	7 – 6	2074 407	2074 407L
3,0 – 3,5	2074 308	2074 308L	5 – 4	2074 408	2074 408L
4,0 – 5,0	2074 309	2074 309L	3 1/2 – 2 3/4	2074 409	2074 409L
5,5 – 6,0	2074 310	2074 310L	2 5/8 – 2	2074 410	2074 410L



Für Schnabeltype Nr. 2074 101 – 2074 104  
werden Einsätze mit verkürztem Schaft benötigt.

Inserts with shortened shafts are required for  
jaw types No. 2074 101 – 2074 104.



Für zylindrische Typen Nr. 2074 105 – 2074 112  
werden Einsätze mit langem Schaft benötigt.

Inserts with long shafts are required for  
cylindrical types No. 2074 105 – 2074 112.

## Messdrähte für Außengewindemessung

## Wire inserts for external thread measurements



- ▶ 3-Drahtmethode
- ▶ Messrollen gehärtet
- ▶ Ø Tol. ±0,5µ
- ▶ Lieferung paarweise verpackt

- ▶ 3-wire method
- ▶ Hardened rollers
- ▶ Ø tolerance ±0,5µ
- ▶ Delivered in a package (pair)



Bei Trapezgewinde bitte die Steigung angeben.

For trapezoidal please specify pitch.

**2046 1.. :**  
1 Paar Messdrähte im Halter für Mikrometer, Klemmung auf der Mikrometerspindel durch Federring. (Unbedingt Messschrauben-Spindeldurchmesser (Ø6,0 / 6,35 / 6,5 / 8,0mm) angeben.)

**2046 1.. :**  
1 pair of wires in holder for micrometers, spring ring clamping on the micrometer spindle. Specify micrometer spindle diameter (Ø6.0 / 6.35 / 6.5 / 8.0mm).

**2046 2.. :**  
3 Stück Messdrähte mit Öse für Messmaschine

**2046 2.. :**  
3 wire pieces with eyes for measuring device

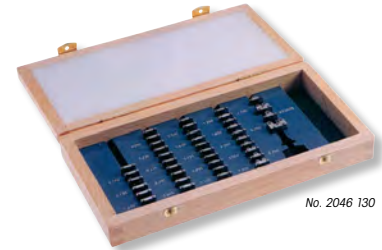

! Andere Durchmesser sowie Messrollen zur Verzahnungsmessung auf Anfrage.

! Other diameters and rollers for gear measurements on request.

Messdraht Wire d Ø mm	Metrisch Metric mm	Withworth Gang / Zoll Thread / inch	UN, UNC, UNF Gang / Zoll Thread / inch	Trapez Trapezoidal	Nº	Nº
0,17	0,25 / 0,3	-	-	-	2046 101	2046 201
0,195	-	-	80	-	2046 102	2046 202
0,22	0,35	-	72	-	2046 103	2046 203
0,25	0,4	60	64	-	2046 104	2046 204
0,29	0,45 / 0,5	-	56	-	2046 105	2046 205
0,335	0,6	48 / 40	48 / 44	-	2046 106	2046 206
0,39	-	40	44 / 36	-	2046 107	2046 207
0,455	0,7 / 0,75 / 0,8	-	32	-	2046 108	2046 208
0,53	0,9	32 / 28	28	-	2046 109	2046 209
0,62	1	26 / 24	24	-	2046 110	2046 210
0,725	1,25	22 / 20 / 19	20	-	2046 111	2046 211
0,895	1,5	18 / 16	18 / 16	1,5	2046 112	2046 212
1,1	1,75	14	14 / 13	2	2046 113	2046 213
1,35	2	12 / 11	12 / 11	-	2046 114	2046 214
1,65	2,5	10 / 9	10 / 9	3	2046 115	2046 215
2,05	3 / 3,5	8 / 7	8 / 7	4	2046 116	2046 216
2,55	4 / 4,5	6	6	5	2046 117	2046 217
3,2	5 / 5,5	5 / 4 1/2	5 / 4 1/2	6	2046 118	2046 218
4,00	6	4 / 3 1/2	4	7 / 8	2046 119	2046 219
5,05	8	3 1/4 / 3 2 7/8 / 2 3/4	-	9 / 10	2046 120	2046 220
6,35	-	2 5/8 / 2 1/2	-	12	2046 121	2046 221
					2046 130	2046 230

Satz im Holzetui (21 Paare) / Set in wooden box (21 pairs)



No. 2046 217

- DØ = Außendurchmesser  
Outer diameter
- FØ = Flankendurchmesser  
Pitch diameter
- M = Prüfmaß  
Test dimension
- S = Gewindesteigung  
Thread pitch
- dØ = Messdrahtdurchmesser  
Wire diameter

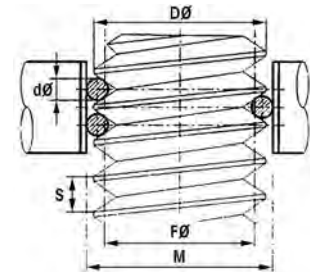

## Sondermessflächen für Bügelmeßschrauben Special measuring faces for external micrometers



Ein Großteil unserer Meßschrauben können mit Sondermessflächen geliefert werden.

Much types of our micrometers can be supplied with special measuring faces.

Zur Angebotsabgabe bitten wir um Ihre Anfrage mit Skizze.

For the preparation of a quotation, please send us your inquiries with a sketch.

Beispiele möglicher Sonderformen:

Examples for possible special designs:

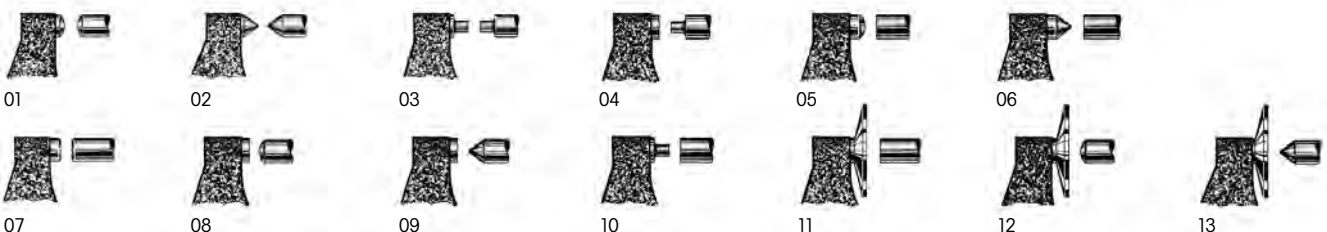



## Bügelmessschrauben für Zahnweitenmessung

## External micrometers for gear tooth measurements



- ▶ Genauigkeit besser als DIN 863
- ▶ Ableseteile mattverchromt
- ▶ Stahlmessflächen gehärtet
- ▶ Spindelklemmung mit Ring
- ▶ Friktionskupplung
- ▶ Handwärmeschutz
- ▶ Lieferung im Etui ohne Einstellmaß

- ▶ Accuracy better than DIN 863
- ▶ Satin chrome reading parts
- ▶ Hardened steel measuring faces
- ▶ Spindle clamping with ring
- ▶ Friction clutch
- ▶ Insulated pads
- ▶ Delivered in a case without setting gauge

**2052 1.. :**  
Spindelsteigung 0,5mm, Messflächen Ø 25mm,  
Modul 0,8 – 6

**2052 1.. :**  
Spindle pitch 0.5mm, measuring faces Ø 25mm,  
module 0.8 – 6

**2052 2.. :**  
Spindelsteigung 1,0mm, Messflächen Ø 30mm,  
Modul 0,8 – 10

**2052 2.. :**  
Spindle pitch 1.0mm, measuring faces Ø 30mm,  
module 0.8 – 10

**2037 1.. :**  
Einstellmaße

**2037 1.. :**  
Setting gauges

**!** Größere Messbereiche sowie  
Hartmetallmessflächen auf Anfrage.

**!** Larger measuring ranges and tungsten  
carbide-tipped measuring faces on request.

mm	Δ mm	kg	Nº	Nº	Nº
0 – 25	0,01	0,3	2052 101	2052 201	-
25 – 50	0,01	0,36	2052 102	2052 202	2037 101
50 – 75	0,01	0,44	2052 103	2052 203	2037 102
75 – 100	0,01	0,55	2052 104	2052 204	2037 103
100 – 125	0,01	0,62	2052 105	2052 205	2037 104
125 – 150	0,01	0,69	2052 106	2052 206	2037 105
150 – 175	0,01	0,81	2052 107	2052 207	2037 106
175 – 200	0,01	0,94	2052 108	2052 208	2037 107
200 – 225	0,01	1,02	2052 109	2052 209	2037 108
225 – 250	0,01	1,16	2052 110	2052 210	2037 109
250 – 275	0,01	1,26	2052 111	2052 211	2037 110
275 – 300	0,01	1,36	2052 112	2052 212	2037 111

> 300mm auf Anfrage / on request

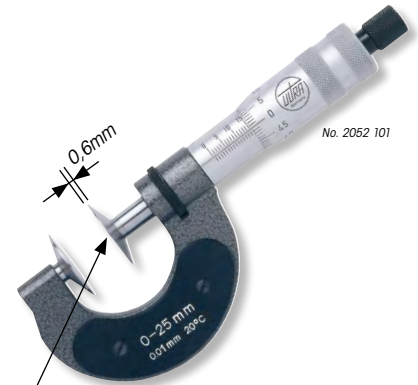

Durchgehend plane Messfläche  
Absolutely, plain meas. surface

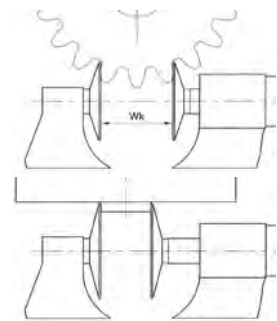
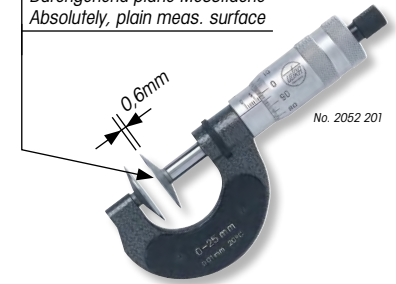

## Bügelmessschrauben STANDARD für Zahnweitenmessung

## External micrometers, STANDARD for gear tooth measurements

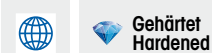

- ▶ DIN 863
- ▶ Spindelsteigung 0,5mm
- ▶ Ableseteile mattverchromt
- ▶ Stahlmessflächen gehärtet
- ▶ Spindelklemmung mit Hebel
- ▶ Gefühlsratsche
- ▶ Handwärmeschutz
- ▶ Lieferung im Etui ohne Einstellmaß

- ▶ DIN 863
- ▶ Spindle pitch 0.5mm
- ▶ Satin chrome reading parts
- ▶ Hardened steel measuring faces
- ▶ Spindle clamping with lever
- ▶ Ratchet stop
- ▶ Insulated pads
- ▶ Delivered in a case without setting gauge

**2052 101s – 2052 104s :**  
Messflächen Ø 20mm,  
Modul 0,8 – 6

**2052 101s – 2052 104s :**  
Measuring faces Ø 20mm,  
module 0.8 – 6

**2052 105s – 2052 106s :**  
Messflächen Ø 30mm,  
Modul 0,8 – 10

**2052 105s – 2052 106s :**  
Measuring faces Ø 30mm,  
module 0.8 – 10

**2037 1.. :**  
Einstellmaße

**2037 1.. :**  
Setting gauges

mm	Δ mm	kg	Nº	Nº
0 – 25	0,01	0,35	2052 101s	-
25 – 50	0,01	0,45	2052 102s	2037 101
50 – 75	0,01	0,56	2052 103s	2037 102
75 – 100	0,01	0,65	2052 104s	2037 103
100 – 125	0,01	0,7	2052 105s	2037 104
125 – 150	0,01	0,80	2052 106s	2037 105

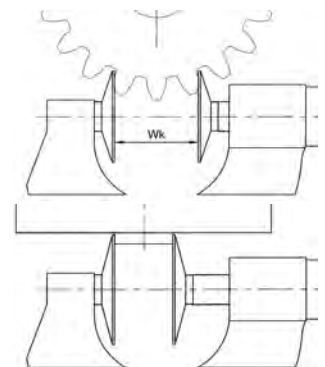

## Bügelmessschrauben für Zahnweitenmessung

## External micrometers for gear tooth measurements



$\leq 1000\text{mm}$

- ▶ Genauigkeit besser als DIN 863
- ▶ Spindelsteigung 1,0mm
- ▶ Ableseteile mattverchromt
- ▶ Stahlmessflächen gehärtet
- ▶ Spindelklemmung mit Ring
- ▶ Friktionskupplung
- ▶ Leichtmetallbügel
- ▶ Handwärmeschutz
- ▶ Lieferung ohne Etui ohne und Einstellmaß

- ▶ Accuracy better than DIN 863
- ▶ Single pitch 1.0mm
- ▶ Satin chrome reading parts
- ▶ Hardened steel measuring faces
- ▶ Spindle clamping with ring
- ▶ Friction clutch
- ▶ Light metal frame
- ▶ Insulated pads
- ▶ Delivered without case and setting gauge

**2052 3.. :**  
Messflächen Ø 35mm, Modul 2 – 10

**2052 3.. :**  
Measuring faces Ø 35mm, module 2 – 10

**2052 4.. :**  
Messflächen Ø 50mm, Modul 2 – 30

**2052 4.. :**  
Measuring faces Ø 50mm, module 2 – 30

**2037 1.. :**  
Einstellmaße

**2037 1.. :**  
Setting gauges

**2027 6.. :**  
Holzetuis

**2027 6.. :**  
Wooden boxes

$\leq$ mm	$\leq$ mm	$\bar{m}$ kg	Nº	Nº	Nº	Nº
300 – 350	0,01	1,65	2052 301	2052 401	2037 112	2027 601
350 – 400	0,01	1,95	2052 302	2052 402	2037 114	2027 602
400 – 450	0,01	2,3	2052 303	2052 403	2037 116	2027 603
450 – 500	0,01	2,45	2052 304	2052 404	2037 118	2027 604
500 – 550	0,01	2,55	2052 305	2052 405	2037 120	2027 605
550 – 600	0,01	3,15	2052 306	2052 406	2037 122	2027 606
600 – 650	0,01	3,45	2052 307	2052 407	2037 124	2027 607
650 – 700	0,01	3,85	2052 308	2052 408	2037 126	2027 608
700 – 750	0,01	4,05	2052 309	2052 409	2037 128	2027 609
750 – 800	0,01	4,25	2052 310	2052 410	2037 130	2027 610
800 – 850	0,01	4,45	2052 311	2052 411	2037 132	2027 611
850 – 900	0,01	5,05	2052 312	2052 412	2037 134	2027 612
900 – 950	0,01	5,95	2052 313	2052 413	2037 136	2027 613
950 – 1000	0,01	6,25	2052 314	2052 414	2037 138	2027 614

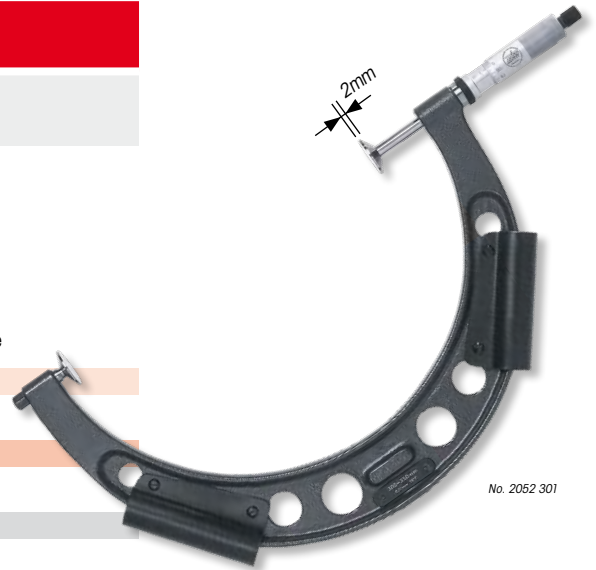

No. 2052 301

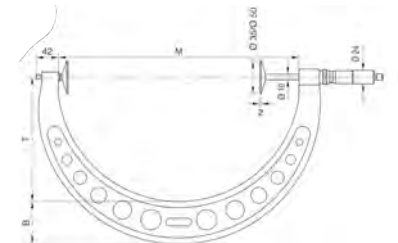

## Vergleichsmessgeräte für Innen- und Außenverzahnung

## Comparative measuring instruments for gear tooth inside and outside

▶ weitere Modelle in Kapitel 6

▶ other models in chapter 6

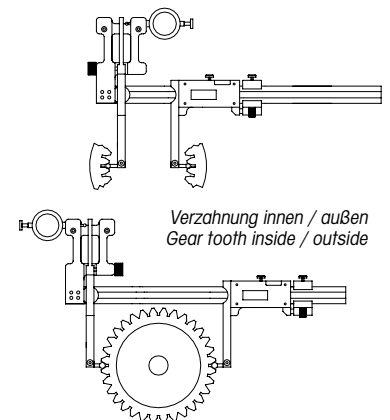
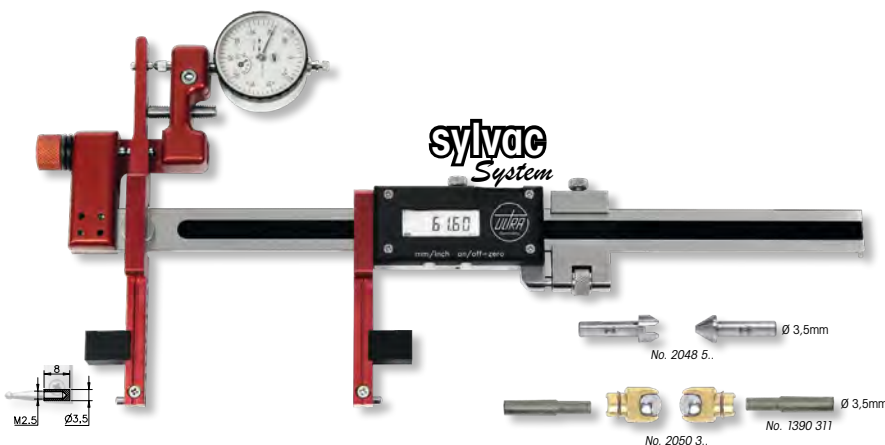

Verzahnung innen / außen  
Gear tooth inside / outside

## Digital-Bügelmessschrauben Präzisionsausführung für Zahnweitenmessung

## Digital external micrometers, Precision model for gear tooth measurements



- ▶ DIN 863
- ▶ Sylvac System
- ▶ großes LCD Display
- ▶ Stahlmessflächen gehärtet
- ▶ nichtdrehende Spindel
- ▶ Spindelsteigung 1mm
- ▶ Messkraft 5 – 10N
- ▶ Handwärmeschutz
- ▶ Lieferung im Etui

### Funktionen:

- ▶ Ein/Aus
- ▶ mm/inch Umschaltung
- ▶ O-Punkt an jeder Position
- ▶ Ablesung umschaltbar 0,01 / 0,001mm
- ▶ Preset Funktion
- ▶ Toleranzwerteingabe
- ▶ Hold Funktion
- ▶ Datenausgang Opto

- ▶ DIN 863
- ▶ Sylvac System
- ▶ Large LCD display
- ▶ Hardened steel measuring faces
- ▶ Non turning spindle
- ▶ Spindle pitch 1mm
- ▶ Measuring force 5 – 10 N
- ▶ Insulated pads
- ▶ Delivered in a case

### Funktionen:

- ▶ On/Off
- ▶ mm/inch commutation
- ▶ Zero setting at any position
- ▶ Reversible reading 0.01 / 0.001mm
- ▶ Preset function
- ▶ Tolerance input
- ▶ Hold function
- ▶ Data output Opto



**2054 1.. :**  
Gefühlsratsche, Spindelklemmung mit Hebel

**2054 1.. :**  
Ratchet stop, spindle clamping with lever

**2054 2.. :**  
mit Anlüftung ca. 2mm, mit Hebel – ideal für Serien- und Vergleichsmessungen, konstante Messkraft durch federbelastete Spindel

**2054 2.. :**  
With lifting device approx. 2mm, with lever – for series and comparative measurements, constant measuring force by spring-loaded spindle

mm	inch approx.	mm / inch	Messflächen Measuring faces mm	kg	Nº	Nº
0 – 25	0 – 1	0,01 / .0005 0,001 / .00005	Ø 25	0,4	2054 101	2054 201
25 – 50	1 – 2		Ø 25	0,5	2054 102	2054 202
50 – 75	2 – 3		Ø 25	0,6	2054 103	2054 203
75 – 100	3 – 4		Ø 25	0,7	2054 104	2054 204
100 – 125	4 – 5		Ø 30	0,7	2054 105	2054 205
125 – 150	5 – 6		Ø 30	0,9	2054 106	2054 206
150 – 175	6 – 7		Ø 30	1,0	2054 107	2054 207
175 – 200	7 – 8		Ø 30	1,2	2054 108	2054 208
200 – 225	8 – 9		Ø 30	1,3	2054 109	2054 209
225 – 250	9 – 10		Ø 30	1,5	2054 110	2054 210

## Digital-Bügelmessschrauben STANDARD für Zahnweitenmessung

## Digital external micrometers, STANDARD for gear tooth measurements



- ▶ DIN 863
- ▶ großes LCD Display
- ▶ Messflächen gehärtet
- ▶ nicht drehende Spindel
- ▶ Spindelsteigung 0,5mm
- ▶ Gefühlsratsche
- ▶ Handwärmeschutz
- ▶ Lieferung im Etui

### Funktionen:

- ▶ Ein/Aus
- ▶ mm/inch Umschaltung
- ▶ O-Punkt an jeder Position
- ▶ Preset Funktion
- ▶ ABS/INC umschaltbar

- ▶ DIN 863
- ▶ Large LCD display
- ▶ Hardened measuring faces
- ▶ Non turning spindle
- ▶ Spindle pitch 0.5mm
- ▶ Ratchet stop
- ▶ Insulated pads
- ▶ Delivered in a case

### Funktionen:

- ▶ On/Off
- ▶ mm/inch commutation
- ▶ Zero setting at any position
- ▶ Preset function
- ▶ ABS/INC reversible



mm	inch approx.	mm	inch	Messflächen Measuring faces mm	kg	Nº
0 – 25	0 – 1	0,001	.00005	Ø20	0,35	5000 301
25 – 50	1 – 2	0,001	.00005	Ø20	0,45	5000 302

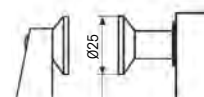

## Bügelmessschrauben für Außenverzahnungsmessung

## External micrometers for gear measurements



- ▶ Genauigkeit besser als DIN 863
- ▶ Ablesefelle mattverchromt
- ▶ Messenden Ø 3x8mm gehärtet
- ▶ Spindelsteigung 0,5mm
- ▶ Spindelklemmung mit Ring
- ▶ Friktionskupplung
- ▶ Handwärmeschutz
- ▶ Lieferung im Etui ohne Messkugeln

- ▶ Accuracy better than DIN 863
- ▶ Satin chrome reading parts
- ▶ Hardened measuring ends Ø 3x8mm
- ▶ Spindle pitch 0.5mm
- ▶ Spindle clamping with ring
- ▶ Friction clutch
- ▶ Insulated pads
- ▶ Delivered in a case without measuring balls

! Messkugeln im Halter Nr. 2050 3.. bitte separat bestellen; größere Messbereiche auf Anfrage.

! Please order measuring balls in holder No. 2050 3.. separately; larger measuring ranges on request.

mm	≤ mm	kg	Nº
0 - 25	0,01	0,34	2050 101
25 - 50	0,01	0,41	2050 102
50 - 75	0,01	0,5	2050 103
75 - 100	0,01	0,59	2050 104
100 - 125	0,01	0,66	2050 105

mm	≤ mm	kg	Nº
125 - 150	0,01	0,78	2050 106
150 - 175	0,01	0,91	2050 107
175 - 200	0,01	0,99	2050 108
200 - 225	0,01	1,13	2050 109
225 - 250	0,01	1,23	2050 110

> 250mm auf Anfrage / on request

Auch zur Gewindeprüfung geeignet (große Flankendurchmesser). Also suitable for thread measurement (large pitch dia.).



No. 2050 101

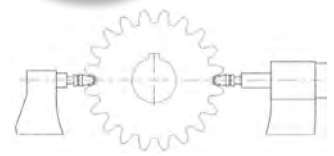

## Innenmessschrauben für Verzahnungsmessung

## Internal micrometers for gear measurements



- ▶ Genauigkeit besser als DIN 863
- ▶ Ablesefelle mattverchromt
- ▶ Messenden Ø 3x8mm gehärtet
- ▶ Spindelsteigung 0,5mm
- ▶ Lieferung im Etui ohne Messkugeln

- ▶ Accuracy better than DIN 863
- ▶ Satin chrome reading parts
- ▶ Hardened measuring ends Ø 3x8mm
- ▶ Spindle pitch 0.5mm
- ▶ Delivered in a case without measuring balls

2051 101 – 2051 102 : Schnabelltype

2051 101 – 2051 102 : Jaw type

2051 103 – 2051 108 : zylindrische Typen, mit Verlängerungsstäben

2051 103 – 2051 108 : Cylindrical type, with extension rods

! Messkugeln im Halter Nr. 2050 3.. bitte separat bestellen.

! Please order measuring balls in holder No. 2050 3.. separately.

! Auch für Innengewindemessung > Ø 100mm ab Steigung 3mm geeignet.

! Also suitable for internal thread measurements > Ø 100mm from 3mm pitch.

mm	≤ mm	kg	Nº
25 - 50	0,01	0,28	2051 101
50 - 75	0,01	0,28	2051 102
75 - 100	0,01	0,08	2051 103
75 - 175	0,01	0,15	2051 104

mm	≤ mm	kg	Nº
75 - 275	0,01	0,25	2051 105
75 - 475	0,01	0,43	2051 106
75 - 875	0,01	0,8	2051 107
75 - 1475	0,01	1,35	2051 108



No. 2051 101



No. 2051 103

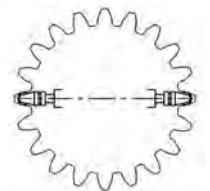

## Messkugeln im Halter, Paar für Nr. 2050 1.. und Nr. 2051 1..

## Measuring balls in holder, pair for No. 2050 1.. and No. 2051 1..

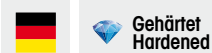

- ▶ Spezialstahl gehärtet
- ▶ Genauigkeit ± 1µ
- ▶ Bohrung Ø 3mm
- ▶ Lieferung paarweise verpackt

- ▶ Hardened special steel
- ▶ Accuracy ± 1µ
- ▶ Bore Ø 3mm
- ▶ Delivered in a package (pair)

! Andere Ø sowie Hartmetallkugeln auf Anfrage.

! Other Ø and tungsten carbide balls on request.



No. 2050 3..

Kugel / Ball Ø mm	für Modul for module	Nº
1,5	0,8 / 0,9	2050 301
1,75	1 / 1,125	2050 301x
2	1,25	2050 302
2,25	1,5	2050 302x
2,5	1,75	2050 303
3	2	2050 304
3,5	2,25	2050 305
4	2,5 / 2,75	2050 306

Kugel / Ball Ø mm	für Modul for module	Nº
4,5	3	2050 307
5	3,25 / 3,5	2050 308
5,5	3,75	2050 309
6	4	2050 310
6,5	4,25 / 4,5	2050 311
7	4,5	2050 312
7,5	5	2050 313
8	5,5	2050 314

Kugel / Ball Ø mm	für Modul for module	Nº
9	6	2050 315
10	6,5	2050 316
10,5	7	2050 317
11	7,5	2050 318
12	8	2050 319
13	8,5 / 9	2050 320
14	9,5	2050 321
15	10	2050 322

**Digital-Innenmessschrauben Sätze  
für Verzahnungsmessung  
mit federnd gelagerten Endmaßstäben**

**Digital internal micrometers sets  
for gear measurements  
with spring-loaded extension rods**



**★ NEW**

**Sylvac  
System**

**Gehärtet  
Hardened**

- ▶ DIN 863
- ▶ Sylvac System
- ▶ Messenden Ø 3x7mm gehärtet
- ▶ nicht drehende Spindel
- ▶ Handwärmeschutz
- ▶ Lieferung im Etui

**Funktionen:**

- ▶ Ein/Aus
- ▶ mm/inch Umschaltung
- ▶ 0-Punkt an jeder Position
- ▶ Ablesung umschaltbar 0,01 / 0,001mm
- ▶ ± Preset Funktion
- ▶ Hold Funktion
- ▶ Datenausgang Opto

**!** Messkugeln im Halter Nr. 2050 4.. bitte separat bestellen.

**!** Einzelne Verlängerungen und größere Messbereiche auf Anfrage.

- ▶ DIN 863
- ▶ Sylvac System
- ▶ Hardened measuring ends Ø 3x7mm
- ▶ Non-turning spindle
- ▶ Insulated pads
- ▶ Delivered in a case

**Funktionen:**

- ▶ On/Off
- ▶ mm/inch commutation
- ▶ Zero setting at any position
- ▶ Reversible reading 0.01 / 0.001mm
- ▶ ± Preset function
- ▶ Hold function
- ▶ Data output Opto

**!** Please order measuring balls in holder No. 2050 4.. separately.

**!** Single extension rods and larger measuring ranges on request.

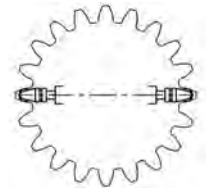

mm		inch approx.		mm		inch		kg		Nº	
200 - 400	8 - 16	0,01 / 0,001	.0005 / .00005	25 / 50 / 100	0,44	2051 501					
200 - 600	8 - 24	0,01 / 0,001	.0005 / .00005	25 / 50 / 100 / 200	0,72	2051 502					
200 - 1000	8 - 40	0,01 / 0,001	.0005 / .00005	25 / 50 / 100 / 200 / 400	1,28	2051 503					
200 - 1600	8 - 63	0,01 / 0,001	.0005 / .00005	25 / 50 / 100 / 200 / 200 / 400 / 400	1,84	2051 504					
> 1600mm auf Anfrage / on request											
Datenkabel RS232 (2m) / Data cable RS232 (2m)										1850 203	
Datenkabel USB (2m) / Data cable USB (2m)										1850 204	

**Messkugeln im Halter, Paar  
für Nr. 2051 5..**

**Measuring balls in holder, pair  
for No. 2051 5..**



**Gehärtet  
Hardened**

- ▶ Spezialstahl gehärtet
- ▶ Genauigkeit ± 1µ
- ▶ Bohrung Ø 3mm
- ▶ Lieferung paarweise verpackt

**!** Andere Ø sowie Hartmetallkugeln auf Anfrage.

- ▶ Hardened special steel
- ▶ Accuracy ± 1µ
- ▶ Bore Ø 3mm
- ▶ Delivered in a package (pair)

**!** Other Ø and tungsten carbide balls on request.



Kugel / Ball Ø mm	für Modul for module	Nº	Kugel / Ball Ø mm	für Modul for module	Nº	Kugel / Ball Ø mm	für Modul for module	Nº
1,5	0,9 / 1,0	2050 401	4,5	3	2050 407	9	6	2050 415
1,75	1,125	2050 401x	5	3,25 / 3,5	2050 408	10	6,5	2050 416
2	1,25	2050 402	5,5	3,75	2050 409	10,5	7	2050 417
2,25	1,5	2050 402x	6	4	2050 410	11	7,5	2050 418
2,5	1,75	2050 403	6,5	4,25 / 4,5	2050 411	12	8	2050 419
3	2	2050 404	7	4,5	2050 412	13	8,5 / 9	2050 420
3,5	2,25	2050 405	7,5	5	2050 413	14	9,5	2050 421
4	2,5 / 2,75	2050 406	8	5,5	2050 414	15	10	2050 422

## Verzahnungslehren und Verzahnungsmessgeräte

## Serration and spline gauges, measuring instruments for gear tooth



► weitere Modelle in Kapitel 3 und 6

► Other models in chapter 3 and 6



Keilnaben- und  
Keilwellenprofil

Straight sided splines



Evolventenverzahnung  
Involute splines



Kerbverzahnung  
Serration splines



## Bügelmessschrauben mit Prismenamboss

## External micrometers with V anvil



- DIN 863
- Ablese Teile mattverchromt
- Spindelsteigung 0,5mm
- Hartmetallmessflächen Ø 6,5mm
- Spindelklemmung mit Hebel
- Gefühlsratsche
- Handwärmeschutz
- Lieferung im Etui

- DIN 863
- Satin chrome reading parts
- Spindle pitch 0.5mm
- Tungsten carbide measuring faces Ø 6.5mm
- Spindle clamping with lever
- Ratchet stop
- Insulated pads
- Delivered in a case



No. 2058 1..

**2056 1.. :**  
Amboss 60° für 3- und 9-schneidige Werkstücke

**2056 1.. :**  
V anvil 60° for 3- and 9-edged tools

**2057 1.. :**  
Amboss 108° für 5-schneidige Werkstücke

**2057 1.. :**  
V anvil 108° for 5-edged tools

**2058 1.. :**  
Amboss 128° für 7-schneidige Werkstücke

**2058 1.. :**  
V anvil 128° for 7-edged tools

mm	Δε mm	kg	Nº	Nº
1 - 15	0,01	0,52	2056 101	-
3 - 20	0,01	0,67	2056 102	-
20 - 35	0,01	0,87	2056 103	-
35 - 50	0,01	1,07	2056 104	-
50 - 65	0,01	1,1	2056 105	-
65 - 80	0,01	1,3	2056 106	-
5 - 25	0,01	0,55	2057 101	2058 101
25 - 45	0,01	0,7	2057 102	2058 102
45 - 65	0,01	0,9	2057 103	2058 103
65 - 85	0,01	1,1	2057 104	2058 104
85 - 105	0,01	1,3	2057 105	2058 105

3-schneidig  
3-edged



5-schneidig  
5-edged



**Digital-Bügelmessschrauben STANDARD mit flachen Messenden**

**Digital external micrometers, STANDARD with flat measuring ends**



- ▶ DIN 863
- ▶ großes LCD Display
- ▶ Messflächen gehärtet
- ▶ nicht drehende Spindel
- ▶ Spindelsteigung 0,5mm
- ▶ Gefühlsratsche
- ▶ Handwärmeschutz
- ▶ Lieferung im Etui

**Funktionen:**

- ▶ Ein/Aus
- ▶ mm/inch Umschaltung
- ▶ O-Punkt an jeder Position
- ▶ Preset Funktion
- ▶ ABS/INC umschaltbar

- ▶ DIN 863
- ▶ Large LCD display
- ▶ Hardened measuring faces
- ▶ Non turning spindle
- ▶ Spindle pitch 0.5mm
- ▶ Ratchet stop
- ▶ Insulated pads
- ▶ Delivered in a case

**Funktionen:**

- ▶ On/Off
- ▶ mm/inch commutation
- ▶ Zero setting at any position
- ▶ Preset function
- ▶ ABS/INC reversible

mm	$\frac{1}{16}$ inch approx.	mm	$\frac{1}{1000}$ inch	Messflächen Measuring faces mm	kg	Nº
0 - 25	0 - 1	0,001	.00005	0,75 x 6,5	0,35	5000 401
25 - 50	1 - 2	0,001	.00005	0,75 x 6,5	0,45	5000 402



No. 5000 401

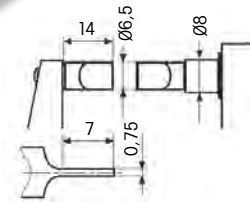

**Digital-Bügelmessschrauben STANDARD mit auswechselbaren Einsätzen**

**Digital external micrometers, STANDARD with interchangeable inserts**



- ▶ DIN 863
- ▶ großes LCD Display
- ▶ Messflächen gehärtet
- ▶ nicht drehende Spindel
- ▶ Spindelsteigung 0,5mm
- ▶ Gefühlsratsche
- ▶ Handwärmeschutz
- ▶ Lieferung im Etui

**Funktionen:**

- ▶ Ein/Aus
- ▶ mm/inch Umschaltung
- ▶ O-Punkt an jeder Position
- ▶ Preset Funktion
- ▶ ABS/INC umschaltbar

- ▶ DIN 863
- ▶ Large LCD display
- ▶ Hardened measuring faces
- ▶ Non turning spindle
- ▶ Spindle pitch 0.5mm
- ▶ Ratchet stop
- ▶ Insulated pads
- ▶ Delivered in a case

**Funktionen:**

- ▶ On/Off
- ▶ mm/inch commutation
- ▶ Zero setting at any position
- ▶ Preset function
- ▶ ABS/INC reversible

mm	$\frac{1}{16}$ inch approx.	mm	$\frac{1}{1000}$ inch	Messflächen Measuring faces mm	kg	Nº
0 - 25	0 - 1	0,001	.00005	7 Paare / 7 pairs	0,35	5000 501
25 - 50	1 - 2	0,001	.00005	7 Paare / 7 pairs	0,45	5000 502



No. 5000 501

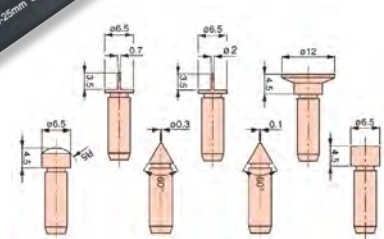

**Digital-Einbaumessschrauben STANDARD**

**Digital micrometer heads STANDARD**



- ▶ Werksnorm
- ▶ Hartmetallmessflächen
- ▶ Spindelsteigung 0,5mm
- ▶ Gefühlsratsche
- ▶ Messkraft 5 - 10 N
- ▶ Lieferung im Etui

**Funktionen:**

- ▶ Ein/Aus
- ▶ mm/inch Umschaltung
- ▶ Preset Funktion
- ▶ ABS/INC umschaltbar

- ▶ Works standard
- ▶ Tungsten carbide-tipped measuring faces
- ▶ Spindle pitch 0.5mm
- ▶ Ratchet stop
- ▶ Measuring force 5 - 10 N
- ▶ Delivered in a case

**Funktionen:**

- ▶ On/Off
- ▶ mm/inch commutation
- ▶ Preset function
- ▶ ABS/INC reversible

$\frac{1}{16}$ mm	$\frac{1}{1000}$ mm	Trommel / Thimble Ø mm	Spindel / Spindle Ø mm	L mm	Schaft / Shaft mm	Nº
0 - 25	0,001	18,0	6,5	165	Ø 12 x 17	2069 200s
0 - 50	0,001	18,5	8	240	Ø 12 x 35	2069 201s



No. 2069 201s

No. 2069 200s

## Bügelmessschrauben Präzisionsausführung mit flachen Messenden

## External micrometers, precision model with flat measuring ends



**Gehärtet  
Hardened**

- ▶ Genauigkeit besser als DIN 863
- ▶ Ablesefelle mattverchromt
- ▶ nicht drehende Spindel
- ▶ Spindelsteigung 0,5mm
- ▶ ohne Spindelklemmung
- ▶ Friktionskupplung
- ▶ Handwärmeschutz
- ▶ Lieferung im Etui, ohne Einstellmaße

- ▶ Accuracy better than DIN 863
- ▶ Satin chrome reading parts
- ▶ Spindle pitch 0.5mm
- ▶ Non turning spindle
- ▶ Without spindle clamping
- ▶ Friction clutch
- ▶ Insulated pads
- ▶ Delivered in a case, without setting gauges

**2066 1.. :**

Bügelmessschrauben

**2066 1.. :**

External Micrometers

**2037 1.. :**

Einstellmaße

**2037 1.. :**

Setting gauges



No. 2066 101

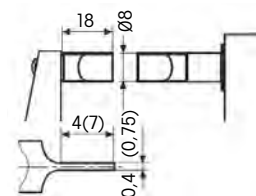

Andere Messflächen 0,75x7 / 2x10 auf Anfrage.  
Other measuring faces 0,75x7 / 2x10 on request.

mm	$\Delta$ mm	Messflächen / Measuring faces mm	kg	Nº	Nº
0 - 25	0,01	0,4 x 4	0,36	2066 101	-
25 - 50	0,01	0,4 x 4	0,43	2066 102	2037 101
50 - 75	0,01	0,75 x 7	0,52	2066 103	2037 102
75 - 100	0,01	0,75 x 7	0,61	2066 104	2037 103
100 - 125	0,01	0,75 x 7	0,68	2066 105	2037 104
125 - 150	0,01	0,75 x 7	0,8	2066 106	2037 105
150 - 175	0,01	0,75 x 7	0,93	2066 107	2037 106
175 - 200	0,01	0,75 x 7	1,01	2066 108	2037 107
200 - 225	0,01	0,75 x 7	1,15	2066 109	2037 108
225 - 250	0,01	0,75 x 7	1,25	2066 110	2037 109

> 250 auf Anfrage / on request

## Bügelmessschrauben Präzisionsausführung für Keilwellenmessung

## External micrometers, precision model for spline shaft measurement



- ▶ Genauigkeit besser als DIN 863
- ▶ Ablesefelle mattverchromt
- ▶ Spindelsteigung 0,5mm
- ▶ Spindelklemmung mit Ring
- ▶ Friktionskupplung
- ▶ Handwärmeschutz
- ▶ Lieferung im Etui, ohne Einstellmaße

- ▶ Accuracy better than DIN 863
- ▶ Satin chrome reading parts
- ▶ Spindle pitch 0.5mm
- ▶ Spindle clamping with ring
- ▶ Friction clutch
- ▶ Insulated pads
- ▶ Delivered in a case, without setting gauges

**2062 1.. :**

Messflächen gehärtet

**2062 1.. :**

Hardened measuring faces

**2062 2.. :**

Hartmetallmessflächen

**2062 2.. :**

Tungsten carbide-tipped measuring faces

**2037 1.. :**

Einstellmaße

**2037 1.. :**

Setting gauges



No. 2062 102

Keilwellenmessung  
Spline shaft measurement

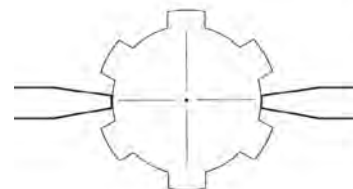

mm	$\Delta$ mm	Messflächen / Measuring faces $\Delta$	$\varnothing$ -mm	kg	Nº	Nº	Nº
0 - 25	0,01	20°	2	0,34	2062 101	2062 201	-
25 - 50	0,01	16°	3	0,41	2062 102	2062 202	2037 101
50 - 75	0,01	12°	4	0,5	2062 103	2062 203	2037 102
75 - 100	0,01	7°	5	0,59	2062 104	2062 204	2037 103



**Bügelmessschrauben Präzisionsausführung mit spitzen Messenden**

**External micrometers, precision model with pointed measuring faces**



**lmm ≤250mm**

- ▶ Genauigkeit besser als DIN 863
- ▶ Hartmetallmessflächen
- ▶ Ableseteile mattverchromt
- ▶ Spindelsteigung 0,5mm
- ▶ Spindelklemmung mit Ring
- ▶ Friktionskupplung
- ▶ Handwärmeschutz
- ▶ Lieferung im Etui, ohne Einstellmaße

- ▶ Accuracy better than DIN 863
- ▶ Tungsten carbide-tipped measuring faces
- ▶ Satin chrome reading parts
- ▶ Spindle pitch 0.5mm
- ▶ Spindle clamping with ring
- ▶ Friction clutch
- ▶ Insulated pads
- ▶ Delivered in a case, without setting gauges

**2064 2.. :**

Bügelmessschrauben

**2064 2.. :**

External Micrometers

**2037 1.. :**

Einstellmaße

**2037 1.. :**

Setting gauges

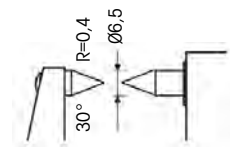

Andere Messflächen  
15°/20°/45°/60° auf Anfrage.  
Other measuring faces  
15°/20°/45°/60° on request.

lmm mm	≤ mm	Messflächen / Measuring faces mm	kg	Nº	Nº
0 - 25	0,01	30° / R = 0,4	0,34	2064 201	-
25 - 50	0,01	30° / R = 0,4	0,41	2064 202	2037 101
50 - 75	0,01	30° / R = 0,4	0,5	2064 203	2037 102
75 - 100	0,01	30° / R = 0,4	0,59	2064 204	2037 103
100 - 125	0,01	30° / R = 0,4	0,66	2064 205	2037 104
125 - 150	0,01	30° / R = 0,4	0,78	2064 206	2037 105
150 - 175	0,01	30° / R = 0,4	0,91	2064 207	2037 106
175 - 200	0,01	30° / R = 0,4	0,99	2064 208	2037 107
200 - 225	0,01	30° / R = 0,4	1,15	2064 209	2037 108
225 - 250	0,01	30° / R = 0,4	1,25	2064 210	2037 109

> 250 auf Anfrage / on request

**Bügelmessschrauben Präzisionsausführung mit dünnen Messzapfen**

**External micrometers, precision model with thin measuring pins**



**lmm ≤250mm**

- ▶ Genauigkeit besser als DIN 863
- ▶ Hartmetallmessflächen
- ▶ Ableseteile mattverchromt
- ▶ Spindelsteigung 0,5mm
- ▶ Spindelklemmung mit Ring
- ▶ Friktionskupplung
- ▶ Handwärmeschutz
- ▶ Lieferung im Etui, ohne Einstellmaße

- ▶ Accuracy better than DIN 863
- ▶ Tungsten carbide-tipped measuring faces
- ▶ Satin chrome reading parts
- ▶ Spindle pitch 0.5mm
- ▶ Spindle clamping with ring
- ▶ Friction clutch
- ▶ Insulated pads
- ▶ Delivered in a case, without setting gauges

**2065 2.. :**

Bügelmessschrauben

**2065 2.. :**

External Micrometers

**2037 1.. :**

Einstellmaße

**2037 1.. :**

Setting gauges

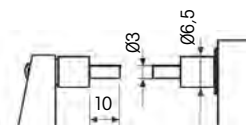

Andere Messflächen  
Ø2x5 / Ø4x12 / Ø5x12 auf Anfrage.  
Other measuring faces  
Ø2x5 / Ø4x12 / Ø5x12 on request.

lmm mm	≤ mm	Messflächen / Measuring faces mm	kg	Nº	Nº
0 - 25	0,01	Ø3 x 10	0,34	2065 201	-
25 - 50	0,01	Ø3 x 10	0,41	2065 202	2037 101
50 - 75	0,01	Ø3 x 10	0,5	2065 203	2037 102
75 - 100	0,01	Ø3 x 10	0,59	2065 204	2037 103
100 - 125	0,01	Ø3 x 10	0,66	2065 205	2037 104
125 - 150	0,01	Ø3 x 10	0,78	2065 206	2037 105
150 - 175	0,01	Ø3 x 10	0,91	2065 207	2037 106
175 - 200	0,01	Ø3 x 10	0,99	2065 208	2037 107
200 - 225	0,01	Ø3 x 10	1,15	2065 209	2037 108
225 - 250	0,01	Ø3 x 10	1,25	2065 210	2037 109

> 250 auf Anfrage / on request

## Bügelmessschrauben STANDARD mit flachen Messenden

## External micrometers, STANDARD with flat measuring ends



**Gehärtet  
Hardened**

- ▶ DIN 863
- ▶ Ablesefläche mattverchromt
- ▶ Nicht drehende Spindel
- ▶ Spindelsteigung 0,5mm
- ▶ Messflächen gehärtet
- ▶ Gefühlsratsche
- ▶ Handwärmeschutz
- ▶ Lieferung im Etui

- ▶ DIN 863
- ▶ Satin chrome reading parts
- ▶ Non turning spindle
- ▶ Spindle pitch 0.5mm
- ▶ Hardened measuring faces
- ▶ Ratchet stop
- ▶ Insulated pads
- ▶ Delivered in a case

Spannweite mm	Genauigkeit mm	Messflächen / Measuring faces mm	Netto kg	Nº
0 - 25	0,01	0,75 x 7	0,3	2066 101s
25 - 50	0,01	0,75 x 7	0,37	2066 102s
50 - 75	0,01	0,75 x 7	0,44	2066 103s
75 - 100	0,01	0,75 x 7	0,53	2066 104s



## Bügelmessschrauben STANDARD mit spitzen Messenden

## External micrometers, STANDARD with pointed measuring faces



**Gehärtet  
Hardened**

- ▶ DIN 863
- ▶ Ablesefläche mattverchromt
- ▶ Spindelsteigung 0,5mm
- ▶ Messflächen gehärtet
- ▶ Gefühlsratsche
- ▶ Handwärmeschutz
- ▶ Lieferung im Etui

- ▶ DIN 863
- ▶ Satin chrome reading parts
- ▶ Spindle pitch 0.5mm
- ▶ Hardened measuring faces
- ▶ Ratchet stop
- ▶ Insulated pads
- ▶ Delivered in a case

Spannweite mm	Genauigkeit mm	Messflächen / Measuring faces mm	Netto kg	Nº
0 - 25	0,01	30° / R = 0,3	0,3	2064 101s
25 - 50	0,01	30° / R = 0,3	0,37	2064 102s
50 - 75	0,01	30° / R = 0,3	0,44	2064 103s
75 - 100	0,01	30° / R = 0,3	0,53	2064 104s



## Bügelmessschrauben STANDARD mit dünnen Messzapfen

## External micrometers, STANDARD with thin measuring faces



**Gehärtet  
Hardened**

- ▶ DIN 863
- ▶ Ablesefläche mattverchromt
- ▶ Spindelsteigung 0,5mm
- ▶ Messflächen gehärtet
- ▶ Gefühlsratsche
- ▶ Handwärmeschutz
- ▶ Lieferung im Etui

- ▶ DIN 863
- ▶ Satin chrome reading parts
- ▶ Spindle pitch 0.5mm
- ▶ Hardened measuring faces
- ▶ Ratchet stop
- ▶ Insulated pads
- ▶ Delivered in a case

Spannweite mm	Genauigkeit mm	Messflächen / Measuring faces mm	Netto kg	Nº
0 - 25	0,01	Ø2 x 5	0,3	2065 101s
25 - 50	0,01	Ø2 x 5	0,37	2065 102s
50 - 75	0,01	Ø2 x 5	0,44	2065 103s
75 - 100	0,01	Ø2 x 5	0,53	2065 104s

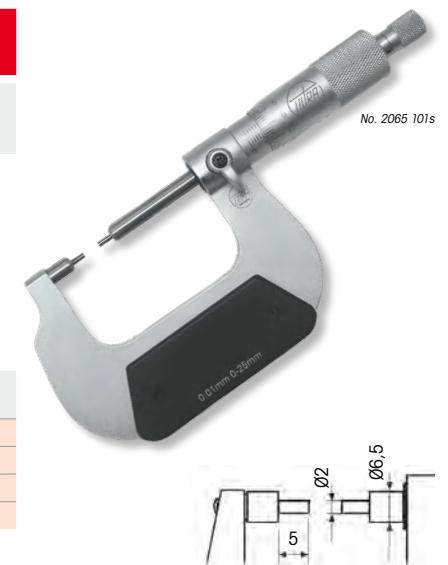

**Bügelmessschrauben STANDARD  
mit auswechselbaren Einsätzen**

**External micrometers, STANDARD  
with interchangeable inserts**



**Gehärtet  
Hardened**

- ▶ DIN 863
- ▶ Ableseteile mattverchromt
- ▶ Spindelsteigung 0,5mm
- ▶ Messflächen gehärtet
- ▶ Gefühlsratsche
- ▶ Handwärmeschutz
- ▶ Lieferung im Etui

- ▶ DIN 863
- ▶ Satin chrome reading parts
- ▶ Spindle pitch 0.5mm
- ▶ Hardened measuring faces
- ▶ Ratchet stop
- ▶ Insulated pads
- ▶ Delivered in a case



mm	< mm	Messflächen / Measuring faces mm	kg	Nº
0 - 25	0,01	7 Paare / 7 pairs	0,37	2066 201s

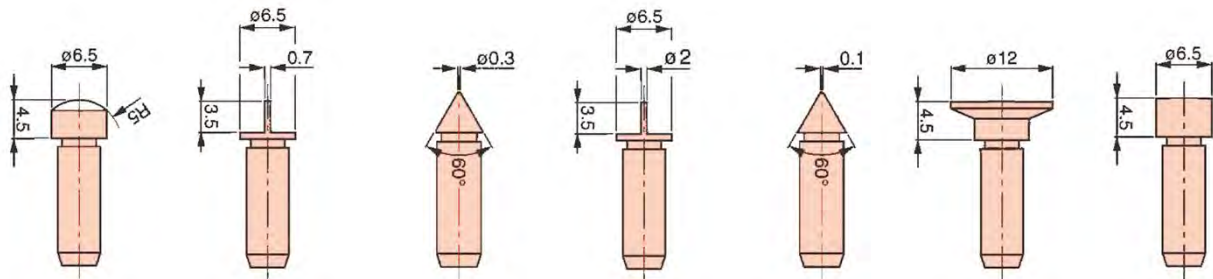

**Bügelmessschrauben STANDARD  
mit gewölbten Messflächen**

**External micrometers, STANDARD  
with spherical measuring faces**



**Gehärtet  
Hardened**

- ▶ DIN 863
- ▶ Ableseteile mattverchromt
- ▶ Spindelsteigung 0,5mm
- ▶ Messflächen gehärtet
- ▶ Gefühlsratsche
- ▶ Handwärmeschutz
- ▶ Lieferung im Etui

- ▶ DIN 863
- ▶ Satin chrome reading parts
- ▶ Spindle pitch 0.5mm
- ▶ Hardened measuring faces
- ▶ Ratchet stop
- ▶ Insulated pads
- ▶ Delivered in a case



mm	< mm	Messflächen / Measuring faces mm	kg	Nº
0 - 25	0,01	∅6,5 / R = 5	0,3	2067 101s
25 - 50	0,01	∅6,5 / R = 5	0,37	2067 102s
50 - 75	0,01	∅6,5 / R = 5	0,44	2067 103s
75 - 100	0,01	∅6,5 / R = 5	0,55	2067 104s

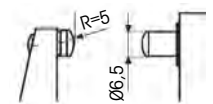

**Messschrauben STANDARD  
für Rohrwandmessungen**

**Micrometers, STANDARD  
for tube-wall measurements**



**Gehärtet  
Hardened**

- ▶ Werksnorm
- ▶ Ableseteile mattverchromt
- ▶ Spindelsteigung 0,5mm
- ▶ Messflächen gehärtet
- ▶ Spindelklemmung mit Hebel
- ▶ Gefühlsratsche
- ▶ Handwärmeschutz
- ▶ Lieferung im Etui

- ▶ Works standard
- ▶ Satin chrome reading parts
- ▶ Spindle pitch 0.5mm
- ▶ Hardened measuring faces
- ▶ Spindle clamping with lever
- ▶ Ratchet stop
- ▶ Insulated pads
- ▶ Delivered in a case



**!** Kleinere oder größere Kugel ∅ auf Anfrage.

**!** Smaller or larger ball ∅ on request.

mm	< mm	Kugel / Ball ∅ mm	Spindel / Spindle ∅ mm	kg	Nº
0 - 25	0,01	4,7	6,5	0,35	5009 102

1  
2  
3  
4  
5  
6  
7  
8  
9  
10  
11  
12  
13  
14  
15

## Bügelmessschrauben tiefe und eckige Bügel

## External micrometers with deep and angular frames



- ▶ Genauigkeit besser als DIN 863
- ▶ Ablesefläche mattverchromt
- ▶ Spindelsteigung 1mm
- ▶ Friktionskupplung
- ▶ Lieferung einzeln verpackt

- ▶ Accuracy better than DIN 863
- ▶ Satin chrome reading parts
- ▶ Spindle pitch 1mm
- ▶ Friction clutch
- ▶ Delivered in individual packages

**A = Messflächen- Messteller Ø**

**A = Measuring faces, measuring discs Ø**

**5010 1.. :**

Messflächen gehärtet

**5010 1.. :**

Tungsten carbide-tipped measuring faces

**5006 2.. :**

Hartmetallmessflächen

**5006 2.. :**

Hardened measuring faces

! Größere Messbereiche und Bügeltiefen auf Anfrage.

! Larger measuring ranges and frame depths on request.

mm	mm	<mm	kg	A Ø mm	Nº	A Ø mm	Nº
0 - 25	50	0,01	0,38	20	5010 103	6,5	5006 202
25 - 50	50	0,01	0,48	-	-	8,0	5006 203
0 - 50	50	0,01	0,55	-	-	8,0	5006 204
0 - 25	100	0,01	0,8	-	-	8,0	5006 207
0 - 25	150	0,01	1,3	20	5010 106	6,5	5006 208
0 - 25	250	0,01	2,2	20	5010 108	6,5	5006 209
0 - 50	100	0,01	0,95	-	-	8	5006 210
0 - 100	100	0,01	1,2	-	-	8	5006 211

> 100mm auf Anfrage / on request



Bügeltiefe bis 300mm und  
Messbereich bis 500mm auf Anfrage.  
Frame depth 300mm and  
meas. range 500mm on request.

## Teilscheiben Messschrauben

## Micrometers with graduated discs for rolling mills



- ▶ DIN 863
- ▶ Ablesefläche mattverchromt
- ▶ Messflächen Ø 6,5mm
- ▶ Spindelsteigung 1mm
- ▶ Friktionskupplung
- ▶ Lieferung einzeln verpackt

- ▶ DIN 863
- ▶ Satin chrome reading parts
- ▶ Measuring faces Ø 6.5mm
- ▶ Spindle pitch 1mm
- ▶ Friction clutch
- ▶ Delivered in individual packages

**5016 1.. :**

Stahlmessflächen gehärtet

**5016 1.. :**

Hardened steel measuring faces

**5016 2.. :**

Hartmetallmessflächen

**5016 2.. :**

Tungsten carbide-tipped measuring faces

**5016 3.. :**

Holzsetui

**5016 3.. :**

Wooden boxes

! Größere Messbereiche, ballige Messflächen oder Handgriff auf Anfrage.

! Larger measuring ranges, spherical measuring faces or handle on request.

mm	mm	<mm	kg	Nº	Nº	Nº
0 - 10	35	0,01	0,27	5016 101	5016 201	5016 301
0 - 15	50	0,01	0,34	5016 102	5016 202	5016 302
0 - 25	50	0,01	0,47	5016 104	5016 204	5016 304
0 - 25	100	0,01	0,8	5016 105	5016 205	5016 305

> 25mm auf Anfrage / on request



No. 5016 204

## Messschrauben STANDARD für Draht- und Kugelmessung

## Micrometers, STANDARD for wire and ball measurements



- ▶ Werknorm
- ▶ Ablesefläche mattverchromt
- ▶ Spindelsteigung 0,5mm
- ▶ Messflächen gehärtet
- ▶ Gefühlsratsche
- ▶ Lieferung im Etui

- ▶ Works standard
- ▶ Satin chrome reading parts
- ▶ Spindle pitch 0.5mm
- ▶ Hardened measuring faces
- ▶ Ratchet stop
- ▶ Delivered in a case



No. 5012 201

mm	<mm	Spindel / Spindle Ø mm	kg	Nº
0 - 10	0,01	6,5	0,2	5012 201

**Höhenmikrometer mit Zählwerk**

**Height micrometer with counter**



**Gehärtet  
Hardened**

- ▶ Werksnorm
- ▶ Messflächen aus Spezialstahl, gehärtet, 2 reihig angeordnet
- ▶ Messbereich durch Untersätze auf 600mm erweiterbar
- ▶ Verstellweg Mikrometer 20mm
- ▶ Ablesung am Gehäuse 5mm Teilstriche, am Zählwerk 0,01mm
- ▶ Standfüße hartmetallbestückt
- ▶ Lieferung einzeln verpackt

- ▶ Works standard
- ▶ Measuring faces made of hardened special steel, arranged in two rows
- ▶ Measuring range extendable to 600mm by stands
- ▶ Adjustable range of micrometer 20mm
- ▶ Reading on the housing 5mm graduation, on counter 0.01mm
- ▶ Tungsten carbide tipped base
- ▶ Delivered in individual packages

**A** : Gesamtgenauigkeit  
**B** : Mikrometergenauigkeit  
**C** : Parallelität Messflächen

**A** : Total accuracy  
**B** : Micrometer accuracy  
**C** : Parallelism of measuring faces

∩ mm	<∩ mm	A mm	B mm	C mm	⚖ kg	Nº
5 – 310	0,01 / 0,001	± 0,003	± 0,0015	0,001	26,0	1818 201



No. 1818 201

**Untersätze für Höhenmikrometer**

**Stands for height micrometer**



**Hartmetall  
Tungsten carbide**

- ▶ Erweiterung des Anwendungsbereichs bis auf 600mm
- ▶ Standfüße hartmetallbestückt
- ▶ Lieferung einzeln verpackt

- ▶ Extension of the application range up to 600 mm
- ▶ Tungsten carbide-tipped base
- ▶ Delivered in individual packages

∩ mm	// mm	⚖ kg	Nº
150 (± 0,0015)	0,001	7,5	1819 201
300 (± 0,0025)	0,0015	13,5	1819 202



No. 1819 202



No. 1819 201

**Tiefenmessschrauben**

**Depth micrometers**



**Gehärtet  
Hardened**

- ▶ Genauigkeit besser als DIN 863
- ▶ Ableseföle mattverchromt
- ▶ Stahlmessflächen gehärtet Ø 6,5mm
- ▶ Spindelsteigung 0,5mm
- ▶ Spindelklemmung mit Ring
- ▶ Friktionskupplung
- ▶ Lieferung im Holzetui

- ▶ Accuracy better than DIN 863
- ▶ Satin chrome reading parts
- ▶ Hardened steel measuring faces Ø 6.5mm
- ▶ Spindle pitch 0.5mm
- ▶ Spindle clamping with ring
- ▶ Friction clutch
- ▶ Delivered in a wooden box

∩ mm	<∩ mm	∩ mm	⚖ kg	Nº
0 – 25	0,01	50	0,21	2092 101
25 – 50	0,01	50	0,22	2092 103
0 – 25	0,01	100	0,27	2092 102
25 – 50	0,01	100	0,28	2092 104
50 – 75	0,01	100	0,29	2092 105
75 – 100	0,01	100	0,3	2092 106



No. 2092 102

## Tiefenmessschrauben mit auswechselbaren Einsätzen

## Depth micrometers with interchangeable inserts



- ▶ Genauigkeit besser als DIN 863
- ▶ Ableseteile mattverchromt
- ▶ Stahlmessflächen gehärtet Ø 4mm
- ▶ Spindelsteigung 0,5mm
- ▶ Spindelklemmung mit Ring
- ▶ Friktionskupplung
- ▶ Lieferung im Holzetui

- ▶ Accuracy better than DIN 863
- ▶ Satin chrome reading parts
- ▶ Hardened steel measuring faces Ø 4mm
- ▶ Spindle pitch 0.5mm
- ▶ Spindle clamping with ring
- ▶ Friction clutch
- ▶ Delivered in a wooden box

! Größere Messtiefen, spitze oder gewölbte Messflächen auf Anfrage. ! Larger measuring depths, points or spherical measuring faces on request.

mm	<math>\leq</math> mm	mm	Einsätze / Inserts Stück / Pieces	kg	Nº
0 - 50	0,01	50	2	0,25	2091 201
0 - 75	0,01	50	3	0,26	2091 202
0 - 75	0,01	100	3	0,34	2091 203
0 - 100	0,01	100	4	0,36	2091 204
0 - 150	0,01	100	6	0,41	2091 205
0 - 200	0,01	100	8	0,46	2091 206
0 - 300	0,01	100	12	0,61	2091 207



No. 2091 203

## Tiefenmessschrauben STANDARD mit auswechselbaren Einsätzen

## Depth micrometers, STANDARD with interchangeable inserts

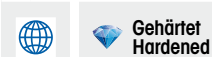

- ▶ DIN 863
- ▶ Ableseteile mattverchromt
- ▶ Stahlmessflächen gehärtet Ø 4,5mm
- ▶ Spindelsteigung 0,5mm
- ▶ Spindelklemmung mit Schraube
- ▶ Gefühlsratsche
- ▶ Lieferung im Etui

- ▶ DIN 863
- ▶ Satin chrome reading parts
- ▶ Hardened steel measuring faces Ø 4.5mm
- ▶ Spindle pitch 0.5mm
- ▶ Spindle clamping with screw
- ▶ Ratchet stop
- ▶ Delivered in a case

mm	<math>\leq</math> mm	mm	Einsätze / Inserts Stück / Pieces	kg	Nº
0 - 100	0,01	100	4	0,36	5025 201
0 - 150	0,01	100	6	0,41	5025 202
0 - 300	0,01	100	12	0,61	5025 203



No. 5025 201

## Messschrauben für Nutenmessung

## Micrometers for grooves

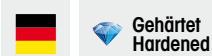

- ▶ DIN 863
- ▶ Ableseteile mattverchromt
- ▶ Stahlmessflächen gehärtet
- ▶ Spindelsteigung 0,5mm
- ▶ Gefühlsratsche
- ▶ Lieferung im Etui

- ▶ DIN 863
- ▶ Satin chrome reading parts
- ▶ Hardened steel measuring faces
- ▶ Spindle pitch 0.5mm
- ▶ Ratchet stop
- ▶ Delivered in a case

A mm	B mm	<math>\leq</math> mm	mm	Bohrung / Bore > Ø D mm	Messteller / Disc Ø mm	kg	Nº
0 - 25	1 - 26	0,01	40	9	8,5	0,29	2083 101
0 - 25	1 - 26	0,01	100	13	12,5	0,33	2083 102
0 - 25	1 - 26	0,01	200	13	12,5	0,4	2083 103
25 - 50	26 - 51	0,01	100	13	12,5	0,46	2083 104
25 - 50	26 - 51	0,01	200	13	12,5	0,46	2083 105

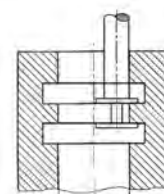
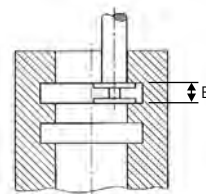
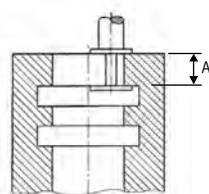

No. 2083 101

## Messschrauben für Keilnutenmessung

## Micrometers for keyway widths

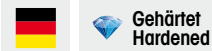

- ▶ DIN 863
- ▶ Ablesung parallaxfrei
- ▶ Ablesteile mattverchromt
- ▶ Stahlmessflächen gehärtet
- ▶ nichtdrehende Spindel
- ▶ Spindelsteigung 0,5mm
- ▶ Gefühlsratsche
- ▶ Lieferung im Etui

- ▶ DIN 863
- ▶ Parallax free reading
- ▶ Satin chrome reading parts
- ▶ Hardened steel measuring faces
- ▶ Non-turning spindle
- ▶ Spindle pitch 0.5mm
- ▶ Ratchet stop
- ▶ Delivered in a case



! Größe 5-30mm auch für die Messung von Scheibenfedernmuten geeignet.

! Size 5-30mm is also suitable for measuring woodruff keys.

mm	mm	mm	Messteller / Disc Ø mm	kg	Nº
5 - 30	0,01	5	30	0,33	2084 101
10 - 35	0,01	8	36	0,46	2084 102
30 - 55	0,01	15	50	0,62	2084 103

## Digital-Innenmessschrauben STANDARD mit Messschnäbeln

## Digital internal micrometers STANDARD with measuring jaws



- ▶ Werksnorm
- ▶ großes LCD Display
- ▶ Hartmetallmessflächen
- ▶ Gefühlsratsche
- ▶ Handwärmeschutz
- ▶ Lieferung im Etui

- ▶ Works standard
- ▶ Large LCD display
- ▶ Tungsten carbide-tipped measuring faces
- ▶ Ratchet stop
- ▶ Insulated pads
- ▶ Delivered in a case



- Funktionen:**
- ▶ Ein/Aus
  - ▶ mm/inch Umschaltung
  - ▶ 0-Punkt an jeder Position
  - ▶ Preset Funktion
  - ▶ ABS/INC umschaltbar

- Functions:**
- ▶ On/Off
  - ▶ mm/inch commutation
  - ▶ Zero setting at any position
  - ▶ Preset function
  - ▶ ABS/INC reversible

mm	inch approx.	mm	inch	kg	Nº
5 - 30	.2 - 1.18	0,001	.00005	0,27	5000 601
25 - 50	1 - 2	0,001	.00005	0,32	5000 602
50 - 75	2 - 3	0,001	.00005	0,47	5000 603
75 - 100	3 - 4	0,001	.00005	0,61	5000 604

## Innenmessschrauben STANDARD mit Messschnäbeln

## Internal micrometers, STANDARD with measuring jaws



- ▶ Werksnorm
- ▶ Ablesteile mattverchromt
- ▶ Hartmetallmessflächen
- ▶ Spindelsteigung 0,5mm
- ▶ Gefühlsratsche
- ▶ Lieferung im Etui

- ▶ Works standard
- ▶ Satin chrome reading parts
- ▶ Tungsten carbide-tipped measuring faces
- ▶ Spindle pitch 0.5mm
- ▶ Ratchet stop
- ▶ Delivered in a case

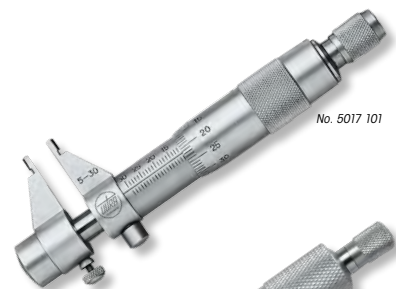

mm	mm	kg	Nº
5 - 30	0,01	0,15	5017 101
25 - 50	0,01	0,2	5017 102
50 - 75	0,01	0,25	5017 103
75 - 100	0,01	0,3	5017 104

## Innenmessschrauben mit Messschnäbeln

## Internal micrometers with measuring jaws



- ▶ Genauigkeit besser als DIN 863
- ▶ Ablese Teile mattverchromt
- ▶ Hartmetallmessflächen
- ▶ Spindelsteigung 0,5mm
- ▶ vorgezogene Friktionskupplung
- ▶ Handwärmeschutz
- ▶ Lieferung im Etui

- ▶ Accuracy better than DIN 863
- ▶ Satin chrome reading parts
- ▶ Tungsten carbide-tipped measuring faces
- ▶ Spindle pitch 0.5mm
- ▶ Friction clutch on thimble
- ▶ Insulated pads
- ▶ Delivered in a case

**2085 201 :**  
Schnäbel beidseitig

**2085 201 :**  
Jaws on both sides

**2085 1.. :**  
Schnäbel einseitig

**2085 1.. :**  
Jaws on one side

! Größere Messbereiche auf Anfrage.

! Larger measuring ranges on request.

mm	<math>\leq</math> mm	kg	Nº
5 – 55	0,01	0,3	2085 201
50 – 75	0,01	0,27	2085 103
75 – 100	0,01	0,33	2085 104
100 – 125	0,01	0,35	2085 105

mm	<math>\leq</math> mm	kg	Nº
125 – 150	0,01	0,38	2085 106
150 – 175	0,01	0,41	2085 107
175 – 200	0,01	0,43	2085 108
> 200mm auf Anfrage / on request			

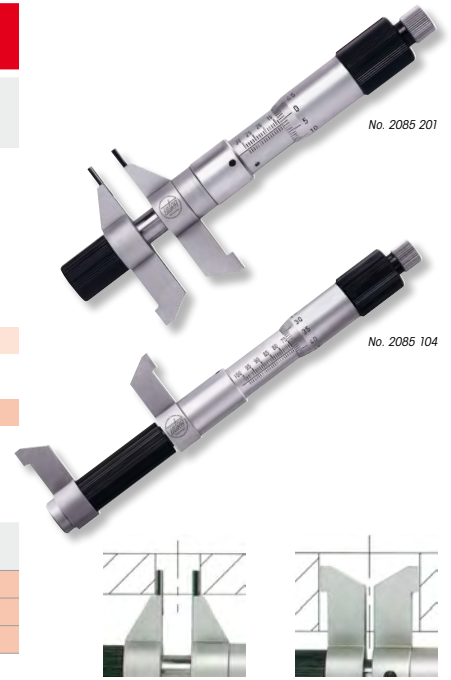

## Innenmessschrauben Sätze STANDARD mit Verlängerungsstäben

## Internal micrometer sets, STANDARD with extension rods



- ▶ Werknorm
- ▶ Genauigkeit  $\pm (3 + n + L / 50)\mu$  (n = Anzahl der Verlängerungen)
- ▶ Ablese Teile mattverchromt
- ▶ Hartmetallmessflächen ballig
- ▶ Spindelsteigung 0,5mm
- ▶ Spindelklemmung mit Schraube
- ▶ Lieferung im Etui

- ▶ Works standard
- ▶ Accuracy  $\pm (3 + n + L / 50)\mu$  (n = numbers of extensions)
- ▶ Satin chrome reading parts
- ▶ Tungsten carbide-tipped, spherical measuring faces
- ▶ Spindle pitch 0.5mm
- ▶ Spindle clamping with screw
- ▶ Delivered in a case

mm	<math>\leq</math> mm	mm	kg	Nº
50 – 600	0,01	13 / 25 / 50 / 100 / 150 / 200	0,61	5018 206



No. 5018 206

## Innenmessschrauben Präzisionsausführung

## Internal micrometers precision model



- ▶ Genauigkeit besser als DIN 863
- ▶ Ablese Teile mattverchromt
- ▶ Messflächen ballig  $\varnothing$  6mm
- ▶ Spindelsteigung 0,5mm
- ▶ Lieferung einzeln verpackt

- ▶ Accuracy better than DIN 863
- ▶ Satin chrome reading parts
- ▶ Spherical measuring faces  $\varnothing$  6mm
- ▶ Spindle pitch 0.5mm
- ▶ Delivered in individual packages

**2080 1.. :**  
Stahlmessflächen gehärtet

**2080 1.. :**  
Hardened steel measuring faces

**2080 2.. :**  
Hartmetallmessflächen

**2080 2.. :**  
Tungsten carbide-tipped measuring faces

! Holzetuis auf Anfrage.

! Wooden boxes on request.

mm	<math>\leq</math> mm	Trommel / Thimble $\varnothing$ mm	kg	Nº	Nº
25 – 30	0,01	15	0,03	2080 101	2080 201
30 – 35	0,01	15	0,03	2080 102	2080 202
35 – 50	0,01	15	0,04	2080 103	2080 203
50 – 75	0,01	16	0,06	2080 104	2080 204
75 – 100	0,01	17	0,09	2080 105	2080 205



No. 2080 102



## Innenmessschrauben Präzisionsausführung

## Internal micrometers precision model



- ▶ Genauigkeit besser als DIN 863
- ▶ Ablesefläche mattverchromt
- ▶ Hartmetallmessflächen ballig Ø 6mm
- ▶ Spindelsteigung 0,5mm
- ▶ Spindelklemmung mit Ring
- ▶ Handwärmeschutz
- ▶ Lieferung einzeln verpackt

- ▶ Accuracy better than DIN 863
- ▶ Satin chrome reading parts
- ▶ Spherical measuring faces Ø 6mm
- ▶ Spindle pitch 0.5mm
- ▶ Spindle clamping with ring
- ▶ Insulated pads
- ▶ Delivered in individual packages



No. 2080 406

! Größere Messbereiche und Holzzeits auf Anfrage.

! Larger measuring ranges and wooden boxes on request.

mm	≤ mm	kg	Nº
100 – 125	0,01	0,16	2080 406
125 – 150	0,01	0,18	2080 407
150 – 175	0,01	0,21	2080 408
175 – 200	0,01	0,24	2080 409
200 – 225	0,01	0,26	2080 410
225 – 250	0,01	0,28	2080 411
250 – 275	0,01	0,3	2080 412
275 – 300	0,01	0,32	2080 413

mm	≤ mm	kg	Nº
300 – 325	0,01	0,34	2080 414
325 – 350	0,01	0,36	2080 415
350 – 375	0,01	0,38	2080 416
375 – 400	0,01	0,4	2080 417
400 – 425	0,01	0,42	2080 418
425 – 450	0,01	0,45	2080 419
450 – 475	0,01	0,47	2080 420
475 – 500	0,01	0,49	2080 421

> 500mm auf Anfrage / > 500mm on request

## Innenmessschrauben Präzisionsausführung

## Internal micrometers precision model



- ▶ Genauigkeit besser als DIN 863
- ▶ Ablesefläche mattverchromt
- ▶ Hartmetallmessflächen ballig Ø 6mm
- ▶ Spindelsteigung 1mm
- ▶ ≥ 150mm mit Handwärmeschutz
- ▶ Lieferung einzeln verpackt

- ▶ Accuracy better than DIN 863
- ▶ Satin chrome reading parts
- ▶ Tungsten carbide-tipped, spherical measuring faces Ø 6mm
- ▶ Spindle pitch 1mm
- ▶ ≥ 150mm with insulated pads
- ▶ Delivered in individual packages



No. 2080 606



No. 2080 607

! Größere Messbereiche und Holzzeits auf Anfrage.

! Larger measuring ranges and wooden boxes on request.

mm	≤ mm	kg	Nº
25 – 30	0,01	0,03	2080 601
30 – 35	0,01	0,03	2080 602
35 – 50	0,01	0,04	2080 603
50 – 70	0,01	0,06	2080 604
70 – 100	0,01	0,09	2080 605
100 – 150	0,01	0,18	2080 606
150 – 200	0,01	0,24	2080 607
200 – 250	0,01	0,28	2080 608
250 – 300	0,01	0,32	2080 609
300 – 350	0,01	0,36	2080 610
350 – 400	0,01	0,4	2080 611
400 – 450	0,01	0,45	2080 612

mm	≤ mm	kg	Nº
450 – 500	0,01	0,49	2080 613
500 – 550	0,01	0,54	2080 614
550 – 600	0,01	0,58	2080 615
600 – 650	0,01	0,63	2080 616
650 – 700	0,01	0,67	2080 617
700 – 750	0,01	0,71	2080 618
750 – 800	0,01	0,75	2080 619
800 – 850	0,01	0,79	2080 620
850 – 900	0,01	0,84	2080 621
900 – 950	0,01	0,88	2080 622
950 – 1000	0,01	0,95	2080 623

> 1000mm auf Anfrage / on request

> 100mm = 50mm Spindelverstellung

> 100mm = 50mm spindle adjustment

## Halter für zylindrische Innenmessschrauben

## Holder for cylindrical-type internal micrometers



- ▶ Lieferung einzeln verpackt

- ▶ Delivered in individual packages



No. 2082 101

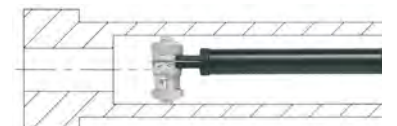

mm	kg	Nº
220	0,10	2082 101

## Innenmessschrauben mit langen Messzapfen Präzisionsausführung

## Internal micrometers with long measuring pins precision model



- ▶ Genauigkeit besser als DIN 863
- ▶ Ablesefläche mattverchromt
- ▶ Hartmetallmessflächen
- ▶ Spindelsteigung 0,5mm
- ▶ Spindelklemmung mit Ring (nicht Nr. 2080 801 – 2080 803)
- ▶ Handwärmeschutz
- ▶ Lieferung einzeln verpackt

- ▶ Accuracy better than DIN 863
- ▶ Satin chrome reading parts
- ▶ Tungsten carbide measuring faces
- ▶ Spindle pitch 0.5mm
- ▶ Spindle clamping with ring (not No. 2080 801 – 2080 803)
- ▶ Insulated pads
- ▶ Delivered in individual packages



No. 2080 801

**I** Holzetuis auf Anfrage

**I** Wooden boxes on request

mm	<math>\leq</math> mm	Typ / type	kg	Nº
75 – 100	0,01	A	0,07	2080 801
75 – 100	0,01	B	0,07	2080 802
100 – 125	0,01	C	0,09	2080 803
125 – 150	0,01	C	0,16	2080 804
150 – 175	0,01	D	0,18	2080 805
175 – 200	0,01	D	0,21	2080 806
200 – 225	0,01	D	0,23	2080 807
225 – 250	0,01	D	0,25	2080 808
250 – 275	0,01	D	0,27	2080 809
275 – 300	0,01	D	0,29	2080 810
300 – 325	0,01	D	0,31	2080 811
325 – 350	0,01	D	0,33	2080 812
350 – 375	0,01	D	0,35	2080 813
375 – 400	0,01	D	0,37	2080 814
400 – 425	0,01	D	0,39	2080 815
425 – 450	0,01	D	0,42	2080 816
450 – 475	0,01	D	0,44	2080 817
475 – 500	0,01	D	0,46	2080 818
500 – 525	0,01	D	0,49	2080 819

mm	<math>\leq</math> mm	Typ / type	kg	Nº
525 – 550	0,01	D	0,51	2080 820
550 – 575	0,01	D	0,53	2080 821
575 – 600	0,01	D	0,55	2080 822
600 – 625	0,01	D	0,57	2080 823
625 – 650	0,01	D	0,6	2080 824
650 – 675	0,01	D	0,62	2080 825
675 – 700	0,01	D	0,64	2080 826
700 – 725	0,01	D	0,66	2080 827
725 – 750	0,01	D	0,68	2080 828
750 – 775	0,01	D	0,7	2080 829
775 – 800	0,01	D	0,72	2080 830
800 – 825	0,01	D	0,74	2080 831
825 – 850	0,01	D	0,76	2080 832
850 – 875	0,01	D	0,79	2080 833
875 – 900	0,01	D	0,81	2080 834
900 – 925	0,01	D	0,83	2080 835
925 – 950	0,01	D	0,85	2080 836
950 – 975	0,01	D	0,87	2080 837
975 – 1000	0,01	D	0,89	2080 838

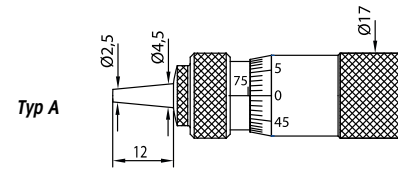

Typ A

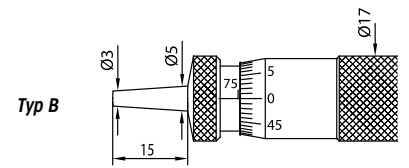

Typ B

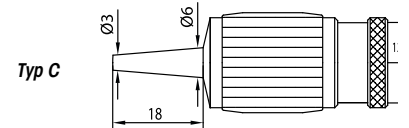

Typ C

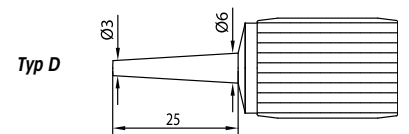

Typ D

## Einbaumessschrauben Präzisionsausführung

## Micrometer heads precision model



Für unser komplettes Sortiment an Einbaumessschrauben fordern Sie bitte unsere separaten technischen Unterlagen an.

For our complete range of micrometer heads, please ask for separate technical documentation.

Wir liefern außerdem Sonderausführungen nach Ihren Zeichnungen.

In addition, we supply special versions according to your drawings.

Auszug aus unserem Lieferprogramm:

Extract from our product range:



No. 3585



No. 20711



No. 3130



No. 3530



No. 20715



No. 3730



No. 3540



No. 3555



No. 3334

## Digital-Innenmessgerät mit Messstiefenanschlag

## Digital internal measuring instrument with measuring depth stop



**CARBON**

||| ≤2000mm

- ▶ Werksnorm
- ▶ Schutzart IP 54, Sylvac System
- ▶ Messflächen gehärtet
- ▶ mit konstanter Messkraft durch Feder
- ▶ Messweg max. 100mm
- ▶ Messflächen ballig R=2mm
- ▶ großes LCD Display
- ▶ Messbereich durch zusätzliche Verlängerungen auf max. 2000mm erweiterbar
- ▶ Lieferung im Holzetui

### Funktionen:

- ▶ Ein/Aus
- ▶ mm/inch Umschaltung
- ▶ ± Preset Funktion
- ▶ 0-Punkt an jeder Position
- ▶ Hold Funktion
- ▶ Datenausgang Opto

- ▶ Works standard
- ▶ Protection class IP54, Sylvac System
- ▶ Measuring faces hardened
- ▶ With constant measuring force due spring
- ▶ Measuring way max. 100mm
- ▶ Spherical measuring faces R=2mm
- ▶ Large LCD display
- ▶ Measuring range extendable through additional extensions to max. 2000mm
- ▶ Delivered in wooden box

### Functions:

- ▶ On/Off
- ▶ mm/inch commutation
- ▶ ± Preset function
- ▶ Zero setting at any position
- ▶ Hold function
- ▶ Data output Opto



No. 2090 501

		<=		⊘	⚖	Nº
mm	inch	mm	inch	mm	kg	
250 - 350	10 - 14	0,01	.0005	0,01	0,8	2090 501
Carbon-Verlängerung 50mm / Carbon-extension 50mm					0,04	2090 551
Carbon-Verlängerung 100mm / Carbon-extension 100mm					0,08	2090 552
Carbon-Verlängerung 200mm / Carbon-extension 200mm					0,12	2090 553
Carbon-Verlängerung 300mm / Carbon-extension 300mm					0,16	2090 554
Carbon-Verlängerung 500mm / Carbon-extension 500mm					0,2	2090 555
Datenkabel RS232 (2m) / Data cable RS232 (2m)						1850 203
Datenkabel USB (2m) / Data cable USB (2m)						1850 204



No. 2090 55

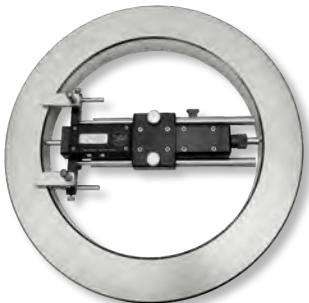

## Einbaumessschrauben STANDARD

## Micrometer heads STANDARD



- ▶ Werksnorm
- ▶ Ablese Teile mattverchromt
- ▶ Spindelsteigung 0,5mm
- ▶ Stahlmessflächen gehärtet
- ▶ Lieferung im einzeln verpackt

- ▶ Works standard
- ▶ Satin chrome reading parts
- ▶ Spindle pitch 0.5mm
- ▶ Hardened steel measuring faces
- ▶ Delivered in individual packages



No. 2069 100s

No. 2069 102s

	<=	Trommel / Thimble	Spindel / Spindle		Schaft / Shaft	Nº
mm	mm	Ø mm	Ø mm	mm	mm	
0 - 6,5	0,01	9	3,5	37	Ø 6 x 6	2069 100s
0 - 13	0,01	13	5,0	58	Ø 9,5 x 9,5	2069 101s

Hartmetallmessflächen, Nonius 0,001mm - parallaxfrei  
Tungsten carbide measuring face, vernier 0,001mm - parallax free

0 - 25	0,01	18	6,5	112	Ø 12 x 17	2069 102s
--------	------	----	-----	-----	-----------	-----------



No. 2069 101s

## Digital-Innenmessschrauben Sätze mit federnd gelagerten Endmaßstäben

## Digital internal micrometer sets with spring-loaded extension rods



No. 2090 101

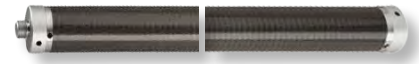

No. 2090 15

- ▶ DIN 863
- ▶ Sylvac System
- ▶ Hartmetallmessflächen ballig
- ▶ nicht drehende Spindel
- ▶ Handwärmeschutz
- ▶ Lieferung im Etui

### Funktionen:

- ▶ Ein/Aus, mm/inch Umschaltung, 0-Punkt an jeder Position, Ablesung umschaltbar 0,01 / 0,001mm, ± Preset Funktion, Hold Funktion, Datenausgang Opto

- ▶ DIN 863
- ▶ Sylvac System
- ▶ Tungsten carbide-tipped, spherical measuring faces
- ▶ Non-turning spindle
- ▶ Insulated pads
- ▶ Delivered in a case

### Funktionen:

- ▶ On/Off, mm/inch commutation, Zero setting at any position, Reversible reading 0.01 / 0.001mm, ± Preset function, Hold function, Data output Opto

! Einzelne Verlängerungen und größere Messbereiche auf Anfrage.

! Single extension rods and larger measuring ranges on request.

mm	inch approx.	mm	inch	mm	kg	Nº
150 - 175	6 - 7	0,01 / 0,001	.0005 / .00005	-	0,2	2090 101
150 - 350	6 - 14	0,01 / 0,001	.0005 / .00005	25 / 50 / 100	0,44	2090 102
150 - 550	6 - 22	0,01 / 0,001	.0005 / .00005	25 / 50 / 100 / 200	0,72	2090 103
150 - 950	6 - 38	0,01 / 0,001	.0005 / .00005	25 / 50 / 100 / 200 / 400	1,28	2090 104
150 - 1550	6 - 62	0,01 / 0,001	.0005 / .00005	25 / 50 / 100 / 200 / 200 / 400 / 400	1,84	2090 105
150 - 1550	6 - 62	0,01 / 0,001	.0005 / .00005	25 / 50 / 100 / 200 / 200 / 400 / 400	1,84	2090 105
> 1550mm auf Anfrage / on request						
Carbon-Verlängerung 500mm / Carbon-extension 500mm					0,6	2090 150
Carbon-Verlängerung 600mm / Carbon-extension 600mm					0,7	2090 151
Carbon-Verlängerung 750mm / Carbon-extension 750mm					0,75	2090 152
Carbon-Verlängerung 1000mm / Carbon-extension 1000mm					1,0	2090 153
Datenkabel RS232 (2m) / Data cable RS232 (2m)						1850 203
Datenkabel USB (2m) / Data cable USB (2m)						1850 204

## Innenmessschrauben Sätze mit federnd gelagerten Endmaßstäben

## Internal micrometer sets with spring-loaded extension rods



≤6000mm



No. 2088 206

- ▶ Genauigkeit besser als DIN 863
- ▶ Ableseile mattverchromt
- ▶ Hartmetallmessflächen ballig Ø 7 x 6mm
- ▶ Spindelverstellung 50mm
- ▶ Handwärmeschutz
- ▶ Lieferung im Holzetui

- ▶ Accuracy better than DIN 863
- ▶ Satin chrome reading parts
- ▶ Tungsten carbide-tipped, spherical measuring faces Ø 7x 6mm
- ▶ Spindle adjustment 50mm
- ▶ Insulated pads
- ▶ Delivered in wooden box

### 2088 2.. :

Spindelsteigung 0,5mm

### 2088 2.. :

Spindle pitch 0.5mm

### 2088 3.. :

Spindelsteigung 1,0mm, verstärkte Ausführung

### 2088 3.. :

Spindle pitch 1.0mm, reinforced model

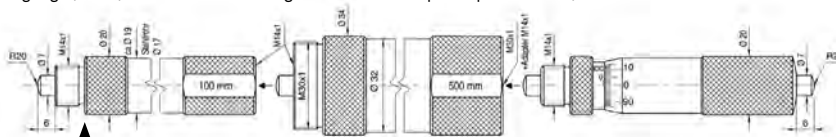

Verlängerungen / Extensions  
50 / 100 / 200 / 400 / 800mm

Verlängerungen verstärkte Ausführung 500/1000mm.  
Extensions reinforced design 500/1000mm.

mm	mm	Ø 17mm	Ø 32mm	kg	Nº
100 - 200	0,01	50	-	0,27	2088 205
100 - 300	0,01	50 / 100	-	0,44	2088 206
100 - 500	0,01	50 / 100 / 200	-	0,72	2088 207
100 - 900	0,01	50 / 100 / 200 / 400	-	1,28	2088 208
100 - 1300	0,01	50 / 100 / 200 / 400 / 400	-	1,84	2088 209
100 - 1700	0,01	50 / 100 / 200 / 400 / 800	-	2,45	2088 210
100 - 2100	0,01	50 / 100 / 200 / 400 / 400 / 800	-	3,01	2088 211
100 - 2500	0,01	50 / 100 / 200 / 400 / 800 / 800	-	3,62	2088 212
Verstärkte Ausführung / Reinforced model					
100 - 2000	0,01	50 / 100 / 200 / 200	500 / 1x 1000	4,2	2088 313
100 - 3000	0,01	50 / 100 / 200 / 200	500 / 2x 1000	6,3	2088 314
100 - 4000	0,01	50 / 100 / 200 / 200	500 / 3x 1000	8,4	2088 315
100 - 5000	0,01	50 / 100 / 200 / 200	500 / 4x 1000	10,5	2088 316
100 - 6000	0,01	50 / 100 / 200 / 200	500 / 5x 1000	12,6	2088 317



Bei großen Messbereichen empfehlen wir die Messschraube an 2 Punkten (ca. 22% der Messlänge vom Ende) aufzulegen.

For large measuring ranges we suggest to put the micrometer on 2 points (approx. 22% of the total length at each end).

**Innenmessschrauben Sätze mit Verlängerungsstäben**

**Internal micrometer sets with extension rods**



- ▶ Genauigkeit besser als DIN 863
- ▶ Ableseföhlen mattverchromt
- ▶ Messflöhlen ballig R=20mm
- ▶ Spindelsteigung 0,5mm
- ▶ Spindelverstellung 25mm
- ▶ Lieferung im Holzetui

- ▶ Accuracy better than DIN 863
- ▶ Satin chrome reading parts
- ▶ Spherical measuring faces R=20mm
- ▶ Spindle pitch 0.5mm
- ▶ Spindle adjustment 25mm
- ▶ Delivered in wooden box



No. 2087 203

**2087 1.. :**  
Stahlmessflöhlen gehärtet

**2087 2.. :**  
Hardened steel measuring faces

**2087 2.. :**  
Hartmetallmessflöhlen

**2087 3.. :**  
Tungsten carbide-tipped measuring faces

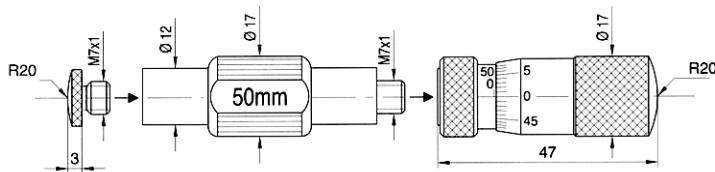

mm	mm	mm	kg	Nº	Nº
50 - 100	0,01	25	0,1	2087 101	2087 201
50 - 150	0,01	25 / 50	0,14	2087 102	2087 202
50 - 250	0,01	25 / 50 / 100	0,24	2087 103	2087 203
50 - 300	0,01	25 / 50 / 50 / 100	0,28	2087 104	2087 204
50 - 450	0,01	25 / 50 / 100 / 200	0,42	2087 105	2087 205
50 - 650	0,01	25 / 50 / 100 / 200 / 200	0,61	2087 106	2087 206
50 - 850	0,01	25 / 50 / 100 / 200 / 400	0,79	2087 107	2087 207
50 - 1250	0,01	25 / 50 / 100 / 200 / 400 / 400	1,15	2087 107x	2087 207x
50 - 1450	0,01	25 / 50 / 100 / 200 / 400 / 600	1,34	2087 108	2087 208
				<b>2087 299</b>	

Messuhr / Dial gauge 0,001mm



No. 2087 299

Messkopf mit Messuhr  
Ø 40mm Ablesung 0,001mm  
Messbereich min. 150mm

Measuring head with dial gauge  
Ø 40mm reading 0.001mm  
smallest range 150mm

**Innenmessschrauben Sätze mit Verlängerungsstäben**

**Internal micrometer sets with extension rods**



- ▶ Genauigkeit besser als DIN 863
- ▶ Ableseföhlen mattverchromt
- ▶ Hartmetallmessflöhlen, ballig R=20mm
- ▶ Spindelsteigung 0,5mm
- ▶ Spindelverstellung 25mm
- ▶ Lieferung im Holzetui

- ▶ Accuracy better than DIN 863
- ▶ Satin chrome reading parts
- ▶ Tungsten carbide-tipped measuring faces, R=20mm
- ▶ Spindle pitch 0.5mm
- ▶ Spindle adjustment 25mm
- ▶ Delivered in wooden box



No. 2087 302



No. 2087 203

! Längere oder dünnere Messzapfen auf Anfrage.

! Longer or thinner measuring pins on request.

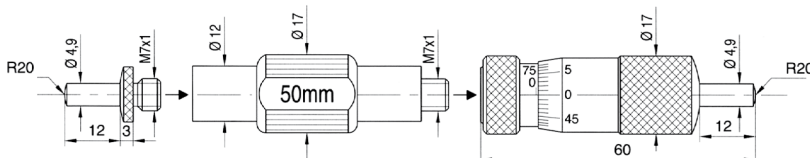

mm	mm	mm	kg	Nº
75 - 100	0,01	-	0,1	2087 301
75 - 175	0,01	25 / 50	0,14	2087 302
75 - 275	0,01	25 / 50 / 100	0,24	2087 303
75 - 325	0,01	25 / 50 / 50 / 100	0,28	2087 304
75 - 475	0,01	25 / 50 / 100 / 200	0,42	2087 305
75 - 675	0,01	25 / 50 / 100 / 200 / 200	0,61	2087 306
75 - 875	0,01	25 / 50 / 100 / 200 / 400	0,79	2087 307
75 - 1275	0,01	25 / 50 / 100 / 200 / 400 / 400	1,15	2087 307x
75 - 1475	0,01	25 / 50 / 100 / 200 / 400 / 600	1,34	2087 308
				<b>2087 399</b>

Messuhr / Dial gauge 0,001mm



No. 2087 399

Messkopf mit Messuhr  
Ø 40mm Ablesung 0,001mm  
Messbereich min. 175mm

Measuring head with dial gauge  
Ø 40mm reading 0.001mm  
smallest range 175mm

## Digital-Innenmessschrauben XTD

## Digital internal micrometers XTD



**BOWERS GROUP**

- ▶ DIN 863
- ▶ Schutzart IP 67, Sylvac System
- ▶ Hartmetallmessflächen  
( < 12,5mm mit Stahlmessflächen gehärtet)
- ▶ großes LCD Display
- ▶ kräftige Ratsche
- ▶ Lieferung im Etui inkl. UKAS-Kalibrierscheine

### Funktionen:

- ▶ Ein/Aus, mm/inch Umschaltung, 0-Punkt an jeder Position, ± Preset Funktion, max. / min. Wertspeicher, Hold Funktion, Datenausgang Proximity

- ▶ DIN 863
- ▶ Protection class IP 67, Sylvac System
- ▶ Tungsten carbide-tipped measuring faces  
( < 12.5mm with steel measuring faces hardened)
- ▶ Large LCD display
- ▶ Sturdy ratchet
- ▶ Delivered in a case incl. UKAS calibration certificates

### Functions:

- ▶ On/Off, mm/inch commutation, Zero setting at any position, ± Preset function, Max. / min. memory, Hold function, Data output Proximity



No. 2502 113

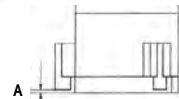

**2501 ... / 2502 ... :**  
inklusive Einstellringe

**2501 ... / 2502 ... :**  
inclusive setting rings

**2501 ...o / 2502 ...o :**  
ohne Einstellringe

**2501 ...o / 2502 ...o :**  
without setting rings



No. 2502 200

mm	inch approx.	mm	inch	L	A	Taster / Probe	mm	kg	Nº	Nº
2 - 2,5	.08 - .10	0,001	.00005	9	1,9	2-P	0,004	1,0	2501 096	2501 096o
2,5 - 3	.10 - .12	0,001	.00005	9	1,9	2-P	0,004	1,0	2501 097	2501 097o
3 - 4	.12 - .16	0,001	.00005	12	1,9	2-P	0,004	1,0	2501 098	2501 098o
4 - 5	.16 - .20	0,001	.00005	18	1,9	2-P	0,004	1,0	2501 099	2501 099o
5 - 6	.20 - .25	0,001	.00005	18	1,9	2-P	0,004	1,0	2501 100	2501 100o
6 - 8	.25 - .3	0,001	.00005	58	1,9	3-P	0,004	0,3	2501 101	2501 101o
8 - 10	.3 - .4	0,001	.00005	58	1,9	3-P	0,004	0,3	2501 102	2501 102o
10 - 12,5	.4 - .5	0,001	.00005	58	1,9	3-P	0,004	0,3	2501 103	2501 103o
12,5 - 16	.5 - .6	0,001	.00005	62	0,5	3-P	0,004	0,3	2502 104	2502 104o
16 - 20	.6 - .8	0,001	.00005	62	0,5	3-P	0,004	0,5	2502 106	2502 106o
20 - 25	.8 - 1	0,001	.00005	66	0,5	3-P	0,004	0,5	2502 107	2502 107o
25 - 35	1 - 1.37	0,001	.00005	66	0,5	3-P	0,004	0,5	2502 109	2502 109o
35 - 50	1.37 - 2	0,001	.00005	80	0,5	3-P	0,004	1,1	2502 111	2502 111o
50 - 65	2 - 2.55	0,001	.00005	80	0,5	3-P	0,005	1,1	2502 113	2502 113o
65 - 80	2.55 - 3.15	0,001	.00005	80	0,5	3-P	0,005	1,1	2502 114	2502 114o
80 - 100	3.15 - 4	0,001	.00005	100	0,5	3-P	0,005	1,2	2502 115	2502 115o
100 - 125	4 - 5	0,001	.00005	115	0,2	3-P	0,006	2,1	2502 116	2502 116o
125 - 150	5 - 6	0,001	.00005	115	0,2	3-P	0,006	2,7	2502 117	2502 117o
150 - 175	6 - 7	0,001	.00005	115	0,2	3-P	0,007	3,5	2502 118	2502 118o
175 - 200	7 - 8	0,001	.00005	115	0,2	3-P	0,007	3,8	2502 119	2502 119o
200 - 225	8 - 9	0,001	.00005	118	0,2	3-P	0,008	3,8	2502 120	2502 120o
225 - 250	9 - 10	0,001	.00005	118	0,2	3-P	0,008	3,8	2502 121	2502 121o
250 - 275	10 - 11	0,001	.00005	118	0,2	3-P	0,009	3,8	2502 122	2502 122o
275 - 300	11 - 12	0,001	.00005	118	0,2	3-P	0,009	3,8	2502 123	2502 123o

Sätze im Holzetui inkl. Einstellringe / Sets in wooden box incl. setting rings

2 - 6	.08 - .25	0,001	.00005	9 / 12 / 18	1,9	2-P	0,004	2,0	2501 200	
6 - 10	.25 - .4	0,001	.00005	58	1,9	3-P	0,004	2,0	2502 201	
10 - 20	.4 - .8	0,001	.00005	58 / 62	1,9 / 0,5	3-P	0,004	2,0	2502 202	
20 - 50	.8 - 2	0,001	.00005	66 / 80	0,5	3-P	0,004	3,2	2502 203	
50 - 100	2 - 4	0,001	.00005	80 / 100	0,5	3-P	0,005	5,0	2502 204	
100 - 150	4 - 6	0,001	.00005	115	0,5	3-P	0,006	7,0	2502 205	
150 - 200	6 - 8	0,001	.00005	115	0,5	3-P	0,007	12,0	2502 206	
100 - 200	4 - 8	0,001	.00005	115	0,5	3-P	0,006 / 0,007	18,5	2502 207	
									1850 203ip	
									1850 204ip	

Datenkabel RS232 (2m) / Data cable RS232 (2m)

Datenkabel USB (2m) / Data cable USB (2m)

**Digital-Innenmessschrauben mit Bluetooth-Funktion XTD**

**Digital internal micrometers with Bluetooth function XTD**

- ▶ DIN 863
- ▶ Schutzart IP 67, Sylvac System
- ▶ Hartmetallmessflächen (< 12,5mm mit Stahlmessflächen gehärtet)
- ▶ großes LCD Display
- ▶ mit Bluetooth-Funktion und SylvacBT Smart App zur kabellosen Datenübertragung
- ▶ kräftige Ratsche
- ▶ Lieferung im Etui inkl. UKAS-Kalibrierschein

**Funktionen:**

- ▶ Ein/Aus, mm/inch Umschaltung, 0-Punkt an jeder Position, ± Preset Funktion, max. / min. Wertspeicher, Hold Funktion, Datenausgang Proximity

- ▶ DIN 863
- ▶ Protection class IP 67, Sylvac System
- ▶ Tungsten carbide-tipped measuring faces (< 12.5mm with steel measuring faces hardened)
- ▶ Large LCD display
- ▶ With Bluetooth function and SylvacBT Smart App for a wireless data transmission
- ▶ Sturdy ratchet
- ▶ Delivered in a case incl. UKAS calibration certificates

**Funktionen:**

- ▶ On/Off, mm/inch commutation, Zero setting at any position, ± Preset function, Max. / min. memory, Hold function, Data output Proximity

**2501 ...b / 2502 ...b :**  
inklusive Einstellringe

**2501 ...b / 2502 ...b :**  
inclusive setting rings

**2501 ...bo / 2502 ...bo :**  
ohne Einstellringe

**2501 ...bo / 2502 ...bo :**  
without setting rings



mm	inch approx.	mm	inch	L	A	Taster / Probe	mm	kg	Nº	Nº
2 - 2,5	.08 - .10	0,001	.00005	9	1,9	2-P	0,004	1,0	2501 096b	2501 096bo
2,5 - 3	.10 - .12	0,001	.00005	9	1,9	2-P	0,004	1,0	2501 097b	2501 097bo
3 - 4	.12 - .16	0,001	.00005	12	1,9	2-P	0,004	1,0	2501 098b	2501 098bo
4 - 5	.16 - .20	0,001	.00005	18	1,9	2-P	0,004	1,0	2501 099b	2501 099bo
5 - 6	.20 - .25	0,001	.00005	18	1,9	2-P	0,004	1,0	2501 100b	2501 100bo
6 - 8	.25 - .3	0,001	.00005	58	1,9	3-P	0,004	0,3	2501 101b	2501 101bo
8 - 10	.3 - .4	0,001	.00005	58	1,9	3-P	0,004	0,3	2501 102b	2501 102bo
10 - 12,5	.4 - .5	0,001	.00005	58	1,9	3-P	0,004	0,3	2501 103b	2501 103bo
12,5 - 16	.5 - .6	0,001	.00005	62	0,5	3-P	0,004	0,3	2502 104b	2502 104bo
16 - 20	.6 - .8	0,001	.00005	62	0,5	3-P	0,004	0,5	2502 106b	2502 106bo
20 - 25	.8 - 1	0,001	.00005	66	0,5	3-P	0,004	0,5	2502 107b	2502 107bo
25 - 35	1 - 1.37	0,001	.00005	66	0,5	3-P	0,004	0,5	2502 109b	2502 109bo
35 - 50	1.37 - 2	0,001	.00005	80	0,5	3-P	0,004	1,1	2502 111b	2502 111bo
50 - 65	2 - 2.55	0,001	.00005	80	0,5	3-P	0,005	1,1	2502 113b	2502 113bo
65 - 80	2.55 - 3.15	0,001	.00005	80	0,5	3-P	0,005	1,1	2502 114b	2502 114bo
80 - 100	3.15 - 4	0,001	.00005	100	0,5	3-P	0,005	1,2	2502 115b	2502 115bo
100 - 125	4 - 5	0,001	.00005	115	0,2	3-P	0,006	2,1	2502 116b	2502 116bo
125 - 150	5 - 6	0,001	.00005	115	0,2	3-P	0,006	2,7	2502 117b	2502 117bo
150 - 175	6 - 7	0,001	.00005	115	0,2	3-P	0,007	3,5	2502 118b	2502 118bo
175 - 200	7 - 8	0,001	.00005	115	0,2	3-P	0,007	3,8	2502 119b	2502 119bo
200 - 225	8 - 9	0,001	.00005	118	0,2	3-P	0,008	3,8	2502 120b	2502 120bo
225 - 250	9 - 10	0,001	.00005	118	0,2	3-P	0,008	3,8	2502 121b	2502 121bo
250 - 275	10 - 11	0,001	.00005	118	0,2	3-P	0,009	3,8	2502 122b	2502 122bo
275 - 300	11 - 12	0,001	.00005	118	0,2	3-P	0,009	3,8	2502 123b	2502 123bo

Sätze im Holzetui inkl. Einstellringe / Sets in wooden box incl. setting rings

2 - 6	.08 - .25	0,001	.00005	9 / 12 / 18	1,9	2-P	0,004	2,0	2501 200b	
6 - 10	.25 - .4	0,001	.00005	58	1,9	3-P	0,004	2,0	2502 201b	
10 - 20	.4 - .8	0,001	.00005	58 / 62	1,9 / 0,5	3-P	0,004	2,0	2502 202b	
20 - 50	.8 - 2	0,001	.00005	66 / 80	0,5	3-P	0,004	3,2	2502 203b	
50 - 100	2 - 4	0,001	.00005	80 / 100	0,5	3-P	0,005	5,0	2502 204b	
100 - 150	4 - 6	0,001	.00005	115	0,5	3-P	0,006	7,0	2502 205b	
150 - 200	6 - 8	0,001	.00005	115	0,5	3-P	0,007	12,0	2502 206b	
100 - 200	4 - 8	0,001	.00005	115	0,5	3-P	0,006 / 0,007	18,5	2502 207b	

Datenkabel RS232 (2m) / Data cable RS232 (2m)

Datenkabel USB (2m) / Data cable USB (2m)

Bluetooth-Dongel (USB) zur kabellosen Datenübertragung (inkl. Treiber und Gage-Wedge Software)  
Bluetooth-Dongle (USB) for wireless data transmission (incl. driver and Gage-Wedge software)

1850 203ip
1850 204ip
1850 215

## Digital-Innen-Schnellmessgeräte XTH

## Digital pistol grip bore gauge XTH



**BOWERS GROUP**

- ▶ DIN 863
- ▶ Schutzart IP 67, Sylvac System
- ▶ Hartmetallmessflächen  
( < 12,5mm mit Stahlmessflächen gehärtet)
- ▶ Pistolengriff
- ▶ großes LCD Display
- ▶ konstante Messkraft, federbelastet
- ▶ Lieferung im Etui inkl. UKAS-Kalibrierscheine

### Funktionen:

- ▶ Ein/Aus, mm/inch Umschaltung, 0-Punkt an jeder Position, ± Preset Funktion, max. / min. Wertspeicher, Hold Funktion, Datenausgang Proximity

- ▶ DIN 863
- ▶ Protection class IP 67, Sylvac System
- ▶ Tungsten carbide-tipped measuring faces  
( < 12.5mm with steel measuring faces hardened)
- ▶ Pistol handle
- ▶ Large LCD display
- ▶ Constant measuring force, spring loaded
- ▶ Delivered in a case incl. UKAS calibration certificates

### Functions:

- ▶ On/Off, mm/inch commutation, Zero setting at any position, ± Preset function, Max. / min. memory, Hold function, Data output Proximity



No. 2510 503

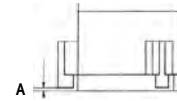

No. 2510 503

### 2510 ... :

inklusive Einstellringe

### 2510 ... :

inklusive setting rings

### 2510 ...o :

ohne Einstellringe

### 2510 ...o :

without setting rings

mm	inch approx.	mm	inch	L	A	Taster/Probe	N	mm	kg	Nº	Nº
2 - 2,5	.08 - .10	0,001	.00005	9	1,9	2-P	10	0,004	1,7	2510 196	2510 196o
2,5 - 3	.10 - .12	0,001	.00005	9	1,9	2-P	10	0,004	1,7	2510 197	2510 197o
3 - 4	.12 - .16	0,001	.00005	12	1,9	2-P	10	0,004	1,7	2510 198	2510 198o
4 - 5	.16 - .20	0,001	.00005	18	1,9	2-P	10	0,004	1,9	2510 199	2510 199o
5 - 6	.20 - .25	0,001	.00005	18	1,9	2-P	10	0,004	1,9	2510 200	2510 200o
6 - 8	.25 - .3	0,001	.00005	58	1,9	3-P	10	0,004	0,3	2510 201	2510 201o
8 - 10	.3 - .4	0,001	.00005	58	1,9	3-P	10	0,004	0,3	2510 202	2510 202o
10 - 12,5	.4 - .5	0,001	.00005	58	1,9	3-P	10	0,004	0,3	2510 203	2510 203o
12,5 - 16	.5 - .6	0,001	.00005	62	0,5	3-P	10	0,004	0,3	2510 204	2510 204o
16 - 20	.6 - .8	0,001	.00005	62	0,5	3-P	10	0,004	0,5	2510 205	2510 205o
20 - 25	.8 - 1	0,001	.00005	66	0,5	3-P	20	0,004	0,5	2510 206	2510 206o
25 - 35	1 - 1.37	0,001	.00005	66	0,5	3-P	20	0,004	0,5	2510 207	2510 207o
35 - 50	1.37 - 2	0,001	.00005	80	0,5	3-P	20	0,004	1,1	2510 208	2510 208o
50 - 65	2 - 2.55	0,001	.00005	80	0,5	3-P	20	0,005	1,1	2510 209	2510 209o
65 - 80	2.55 - 3.15	0,001	.00005	80	0,5	3-P	20	0,005	1,1	2510 210	2510 210o
80 - 100	3.15 - 4	0,001	.00005	85	0,5	3-P	25	0,005	1,2	2510 211	2510 211o
100 - 125	4 - 5	0,001	.00005	100	0,2	3-P	25	0,006	2,1	2510 212	2510 212o
125 - 150	5 - 6	0,001	.00005	100	0,2	3-P	25	0,006	2,7	2510 213	2510 213o
150 - 175	6 - 7	0,001	.00005	100	0,2	3-P	25	0,007	3,5	2510 214	2510 214o
175 - 200	7 - 8	0,001	.00005	100	0,2	3-P	25	0,007	3,8	2510 215	2510 215o
200 - 225	8 - 9	0,001	.00005	100	0,2	3-P	25	0,008	3,8	2510 216	2510 216o
225 - 250	9 - 10	0,001	.00005	100	0,2	3-P	25	0,008	3,8	2510 217	2510 217o
250 - 275	10 - 11	0,001	.00005	100	0,2	3-P	25	0,009	3,8	2510 218	2510 218o
275 - 300	11 - 12	0,001	.00005	100	0,2	3-P	25	0,009	3,8	2510 219	2510 219o

### Sätze im Holzetui inkl. Einstellringe / Sets in wooden box incl. setting rings

2 - 6	.08 - .25	0,001	.00005	9 / 12/ 18	1,9	2-P	10	0,004	2,0	2510 500	
6 - 10	.25 - .4	0,001	.00005	58	1,9	3-P	10	0,004	1,3	2510 501	
10 - 20	.4 - .8	0,001	.00005	58 / 62	1,9 / 0,5	3-P	10	0,004	2,0	2510 502	
20 - 50	.8 - 2	0,001	.00005	66 / 80	0,5	3-P	20	0,004	3,6	2510 503	
50 - 100	2 - 4	0,001	.00005	80 / 100	0,5	3-P	20 / 25	0,005	5,28	2510 504	
100 - 150	4 - 6	0,001	.00005	115	0,5	3-P	25	0,006	7,2	2510 505	
150 - 200	6 - 8	0,001	.00005	115	0,5	3-P	25	0,007	12,0	2510 506	

### Große Sätze / Large sets

6 - 20	.25 - .8	0,001	.00005	58 / 62	1,9 / 0,5	3-P	10	0,004	2,7	2510 507	
20 - 100	.8 - 4	0,001	.00005	66 / 80 / 100	0,5	3-P	20 / 25	0,004 / 0,005	8,4	2510 508	
100 - 200	4 - 8	0,001	.00005	115	0,5	3-P	25	0,006 / 0,007	18,0	2510 509	

Datenkabel RS232 (2m) / Data cable RS232 (2m)

Datenkabel USB (2m) / Data cable USB (2m)

1850 203ip

1850 204ip



## Digital-Innen-Schnellmessgeräte mit Bluetooth-Funktion XTH



- ▶ DIN 863
- ▶ Schutzart IP 67, Sylvac System
- ▶ Hartmetallmessflächen (< 12,5mm mit Stahlmessflächen gehärtet)
- ▶ Pistolengriff
- ▶ großes LCD Display
- ▶ mit Bluetooth-Funktion und SylvacBT Smart App zur kabellosen Datenübertragung
- ▶ konstante Messkraft, federbelastet
- ▶ Lieferung im Etui inkl. UKAS-Kalibrierscheine

### Funktionen:

- ▶ Ein/Aus, mm/inch Umschaltung, 0-Punkt an jeder Position, ± Preset Funktion, max. / min. Wertspeicher, Hold Funktion, Datenausgang Proximity

### 2510 ...b :

inklusive Einstellringe

### 2510 ...bo :

ohne Einstellringe

## Digital pistol grip bore gauge with Bluetooth function XTH



- ▶ DIN 863
- ▶ Protection class IP 67, Sylvac System
- ▶ Tungsten carbide-tipped measuring faces (< 12.5mm with steel measuring faces hardened)
- ▶ Pistol handle
- ▶ Large LCD display
- ▶ With Bluetooth function and SylvacBT Smart App for a wireless data transmission
- ▶ Constant measuring force, spring loaded
- ▶ Delivered in a case incl. UKAS calibration certificates

### Functions:

- ▶ On/Off, mm/inch commutation, Zero setting at any position, ± Preset function, Max. / min. memory, Hold function, Data output Proximity

### 2510 ...b :

inklusive setting rings

### 2510 ...bo :

without setting rings



mm	inch approx.	mm	inch	LJ mm	A mm	Taster/Probe	N	mm	kg	Nº	Nº
2 - 2,5	.08 - .10	0,001	.00005	9	1,9	2-P	10	0,004	1,7	2510 196b	2510 196bo
2,5 - 3	.10 - .12	0,001	.00005	9	1,9	2-P	10	0,004	1,7	2510 197b	2510 197bo
3 - 4	.12 - .16	0,001	.00005	12	1,9	2-P	10	0,004	1,7	2510 198b	2510 198bo
4 - 5	.16 - .20	0,001	.00005	18	1,9	2-P	10	0,004	1,9	2510 199b	2510 199bo
5 - 6	.20 - .25	0,001	.00005	18	1,9	2-P	10	0,004	1,9	2510 200b	2510 200bo
6 - 8	.25 - .3	0,001	.00005	58	1,9	3-P	10	0,004	0,3	2510 201b	2510 201bo
8 - 10	.3 - .4	0,001	.00005	58	1,9	3-P	10	0,004	0,3	2510 202b	2510 202bo
10 - 12,5	.4 - .5	0,001	.00005	58	1,9	3-P	10	0,004	0,3	2510 203b	2510 203bo
12,5 - 16	.5 - .6	0,001	.00005	62	0,5	3-P	10	0,004	0,3	2510 204b	2510 204bo
16 - 20	.6 - .8	0,001	.00005	62	0,5	3-P	10	0,004	0,5	2510 205b	2510 205bo
20 - 25	.8 - 1	0,001	.00005	66	0,5	3-P	20	0,004	0,5	2510 206b	2510 206bo
25 - 35	1 - 1.37	0,001	.00005	66	0,5	3-P	20	0,004	0,5	2510 207b	2510 207bo
35 - 50	1.37 - 2	0,001	.00005	80	0,5	3-P	20	0,004	1,1	2510 208b	2510 208bo
50 - 65	2 - 2.55	0,001	.00005	80	0,5	3-P	20	0,005	1,1	2510 209b	2510 209bo
65 - 80	2.55 - 3.15	0,001	.00005	80	0,5	3-P	20	0,005	1,1	2510 210b	2510 210bo
80 - 100	3.15 - 4	0,001	.00005	85	0,5	3-P	25	0,005	1,2	2510 211b	2510 211bo
100 - 125	4 - 5	0,001	.00005	100	0,2	3-P	25	0,006	2,1	2510 212b	2510 212bo
125 - 150	5 - 6	0,001	.00005	100	0,2	3-P	25	0,006	2,7	2510 213b	2510 213bo
150 - 175	6 - 7	0,001	.00005	100	0,2	3-P	25	0,007	3,5	2510 214b	2510 214bo
175 - 200	7 - 8	0,001	.00005	100	0,2	3-P	25	0,007	3,8	2510 215b	2510 215bo
200 - 225	8 - 9	0,001	.00005	100	0,2	3-P	25	0,008	3,8	2510 216b	2510 216bo
225 - 250	9 - 10	0,001	.00005	100	0,2	3-P	25	0,008	3,8	2510 217b	2510 217bo
250 - 275	10 - 11	0,001	.00005	100	0,2	3-P	25	0,009	3,8	2510 218b	2510 218bo
275 - 300	11 - 12	0,001	.00005	100	0,2	3-P	25	0,009	3,8	2510 219b	2510 219bo

### Sätze im Holzetui inkl. Einstellringe / Sets in wooden box incl. setting rings

2 - 6	.08 - .25	0,001	.00005	9 / 12 / 18	1,9	2-P	10	0,004	2,0	2510 500b	
6 - 10	.25 - .4	0,001	.00005	58	1,9	3-P	10	0,004	1,3	2510 501b	
10 - 20	.4 - .8	0,001	.00005	58 / 62	1,9 / 0,5	3-P	10	0,004	2,0	2510 502b	
20 - 50	.8 - 2	0,001	.00005	66 / 80	0,5	3-P	20	0,004	3,6	2510 503b	
50 - 100	2 - 4	0,001	.00005	80 / 100	0,5	3-P	20 / 25	0,005	5,28	2510 504b	
100 - 150	4 - 6	0,001	.00005	115	0,5	3-P	25	0,006	7,2	2510 505b	
150 - 200	6 - 8	0,001	.00005	115	0,5	3-P	25	0,007	12,0	2510 506b	

### Große Sätze / Large sets

6 - 20	.25 - .8	0,001	.00005	58 / 62	1,9 / 0,5	3-P	10	0,004	2,7	2510 507b	
20 - 100	.8 - 4	0,001	.00005	66 / 80 / 100	0,5	3-P	20 / 25	0,004 / 0,005	8,4	2510 508b	
100 - 200	4 - 8	0,001	.00005	115	0,5	3-P	25	0,006 / 0,007	18,0	2510 509b	

Datenkabel RS232 (2m) / Data cable RS232 (2m)

Datenkabel USB (2m) / Data cable USB (2m)

Bluetooth-Dongel (USB) zur kabellosen Datenübertragung (inkl. Treiber und Gage-Wedge Software)

Bluetooth-Dongle (USB) for wireless data transmission (incl. driver and Gage-Wedge software)

1850 203ip

1850 204ip

1850 215

**Digital-Innen-Schnellmessgeräte für Spezialanwendungen**

**Digital pistol grip bore gauge for special bore measurement**



**BOWERS GROUP**



**NEW**



**IP67**

**Sylvac System**

Wir liefern jede Art von Digital-Innen-Schnellmessgeräten für Ihren speziellen Anwendungsfall – auf Wunsch auch Konzeption und Konstruktion, gegen Berechnung.

We supply all types of custom made digital internal micrometers for your special applications – on request also undertake conception and design at cost.

Zur Angebotserstellung bitten wir um Ihre Anfrage mit Zeichnungsunterlagen.

For the preparation of a quotation, please send us your inquiries with drawings.

**Beispiele für bereits realisierte kundenspezifische Spezialanwendungen:**

**Examples of already executed customer-specific special solutions:**



Digital-Innen-Schnellmessgerät für Kugelgewindeprüfung ab Ø M10.

Digital pistol grip bore gauge to measure ball screw threads from Ø M10.



Digital-Innen-Schnellmessgerät zur Gewindemessung M4 – 300mm / Nr. 8 UN – 12".

Digital pistol grip bore gauge to measure effective, pitch and major diameter between M4 – 300mm / No. 8 UN – 12".

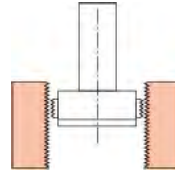

Digital-Innen-Schnellmessgerät für Einstiche von Ø 2-300mm. Optional Tiefenanschläge zur schnelleren Positionierung.

Digital pistol grip bore gauge to measure grooves from Ø 2-300mm. Optional depth stops available for quick location.



Digital-Innen-Schnellmessgerät mit balligen Messflächen für eine gute Wiederholgenauigkeit auch ohne Übereinstimmung der Bohrungsmitte. Lieferbar für Ø 6-300mm.

Digital pistol grip bore gauge with spherical measuring faces for good repeatability even when out of line with bore centre. Available for Ø 6-300mm.

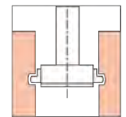
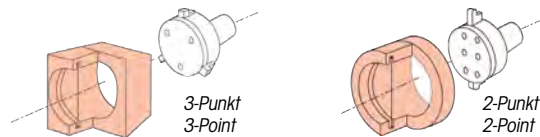

Digital-Innen-Schnellmessgerät für bis zu 2 Meter Messtiefe.

Digital pistol grip bore gauge to measure up to 2 metres measuring depth.



Digital-Innen-Schnellmessgerät für Bremsattel-Nutmessung.

Digital pistol grip bore gauge to measure brake caliper grooves.



**Digital-Innenmessschrauben IP67  
XT500**

**Digital internal micrometers IP67  
XT500**



**NEW**



**IP67**



**Gehärtet  
Hardened**



**Bluetooth®**



**BOWERS GROUP**

- ▶ Werksnorm
- ▶ Schutzart IP 67, Sylvac System
- ▶ Messeinsätze ballig (gehärtet)
- ▶ nur für Durchgangsbohrung
- ▶ großes LCD Display
- ▶ mit konstanter Messkraft
- ▶ kräftige Ratsche
- ▶ Lieferung im Etui inkl. Werks-Kalibrierscheine und inkl. Einstellring 300mm mit UKAS-Kalibrierscheine

**Funktionen:**

- ▶ Ein/Aus
- ▶ mm/inch Umschaltung
- ▶ 0-Punkt an jeder Position
- ▶ Ablesung umschaltbar 0,01 / 0,001mm
- ▶ ± Preset Funktion
- ▶ max. / min. Wertspeicher
- ▶ Hold Funktion
- ▶ Datenausgang Proximity

**Handhabung:**

- ▶ Das Messgerät wird mit dem Referenzmesseinsatz (300 – 325mm) und dem Einstellring Ø 300mm voreingestellt. Weitere Messeinsätze können dann ohne Neueinstellung montiert werden.

**Vorteil: Der Einstellring Ø 300mm reicht aus um das Gerät innerhalb des Messbereich 300 – 500mm vor einzustellen.**

**2503 1.. / 2503 2..**

ohne Bluetooth-Funktion

**2503 1..b / 2503 2..b**

mit Bluetooth-Funktion

**!** Messtiefenverlängerungen auf Anfrage.

- ▶ Works standard
- ▶ Protection class IP 67, Sylvac System
- ▶ Spherical measuring inserts (hardened)
- ▶ for through bores only
- ▶ Large LCD display
- ▶ Constant measuring force
- ▶ Sturdy ratchet
- ▶ Delivered in a case incl. works calibration certificate and incl. setting ring gauge 300mm with UKAS calibration certificates

**Funktionen:**

- ▶ On/Off
- ▶ mm/inch commutation
- ▶ Zero setting at any position
- ▶ Reversible reading 0.01 / 0.001mm
- ▶ ± Preset function
- ▶ Max. / min. memory
- ▶ Hold function
- ▶ Data output Proximity

**Operation:**

- ▶ The setting of the instrument will be made by the master reference set (300 – 325mm) and the setting ring gauge Ø 300mm. The other anvil sets are then fitted as required without pre-setting.

**Advantage: The setting ring gauge Ø 300mm is sufficient to adjust the instrument within the complete measuring range 300 – 500mm.**

**2503 1.. / 2503 2..**

without Bluetooth-Funktion

**2503 1..b / 2503 2..b**

with Bluetooth-Funktion

**!** Measuring depth extensions on request.



mm	inch	mm / inch	L mm	mm	kg	Nº	Nº
300 – 325	12 – 13	0,01 / .0005 0,001 / .00005	120	0,015	8,7	2503 101	2503 101b
300 – 325 325 – 350	12 – 13 13 – 14	0,01 / .0005 0,001 / .00005	120	0,015	8,8	2503 102	2503 102b
300 – 325 350 – 375	12 – 13 14 – 15	0,01 / .0005 0,001 / .00005	120	0,015	8,9	2503 103	2503 103b
300 – 325 375 – 400	12 – 13 15 – 16	0,01 / .0005 0,001 / .00005	120	0,015	9,0	2503 104	2503 104b
300 – 325 400 – 425	12 – 13 16 – 17	0,01 / .0005 0,001 / .00005	120	0,015	9,1	2503 105	2503 105b
300 – 325 425 – 450	12 – 13 17 – 18	0,01 / .0005 0,001 / .00005	120	0,015	9,3	2503 106	2503 106b
300 – 325 450 – 475	12 – 13 18 – 19	0,01 / .0005 0,001 / .00005	120	0,015	9,5	2503 107	2503 107b
300 – 325 475 – 500	12 – 13 19 – 20	0,01 / .0005 0,001 / .00005	120	0,015	9,7	2503 108	2503 108b

**Große Sätze / Large sets**

300 – 400	12 – 16	0,01 / .0005 0,001 / .00005	120	0,015	10,0	2503 201	2503 201b
300 – 325 400 – 500	12 – 13 16 – 20	0,01 / .0005 0,001 / .00005	120	0,015	13,0	2503 202	2503 202b
300 – 500	12 – 20	0,01 / .0005 0,001 / .00005	120	0,015	15,0	2503 203	2503 203b

Datenkabel RS232 (2m) / Data cable RS232 (2m)

1850 203ip

Datenkabel USB (2m) / Data cable USB (2m)

1850 204ip

Bluetooth-Dongle (USB) zur kabellosen Datenübertragung (inkl. Treiber und Gage-Wedge Software)  
Bluetooth-Dongle (USB) for wireless data transmission (incl. driver and Gage-Wedge software)

1850 215

## Innenmessschrauben XTA



- ▶ DIN 863
- ▶ Ablesefläche mattverchromt
- ▶ < 20mm wird XTA MICRO geliefert
- ▶ Hartmetallflächen  
(< 12,5mm mit Stahlmessflächen gehärtet)
- ▶ Spindelsteigung 0,5mm
- ▶ kräftige Ratsche
- ▶ Lieferung im Etui inkl. Einstellringe  
und UKAS-Kalibrierscheine

**2094 ... / 2095 ... :**  
inklusive Einstellringe

**2094 ...o / 2095 ...o :**  
ohne Einstellringe

## Internal micrometers XTA

- ▶ DIN 863
- ▶ Satin chrome reading parts
- ▶ < 20mm XTA MICRO will be delivered
- ▶ Tungsten carbide-tipped measuring faces  
(< 12.5mm with steel measuring faces hardened)
- ▶ Spindle pitch 0.5mm
- ▶ Sturdy ratchet
- ▶ Delivered in a case incl. setting rings  
and UKAS calibration certificates

**2094 ... / 2095 ... :**  
inclusive setting rings

**2094 ...o / 2095 ...o :**  
without setting rings

mm	< mm	L mm	A mm	Taster Probes	mm	kg	Nº	Nº
2 - 2,5	0,002	9	1,9	2-P	0,004	0,5	2094 096	2094 096o
2,5 - 3	0,002	9	1,9	2-P	0,004	0,5	2094 097	2094 097o
3 - 4	0,002	12	1,9	2-P	0,004	0,5	2094 098	2094 098o
4 - 5	0,002	18	1,9	2-P	0,004	0,5	2094 099	2094 099o
5 - 6	0,002	18	1,9	2-P	0,004	0,6	2094 100	2094 100o
6 - 8	0,002	58	1,9	3-P	0,004	0,3	2094 101	2094 101o
8 - 10	0,002	58	1,9	3-P	0,004	0,3	2094 102	2094 102o
10 - 12,5	0,002	58	1,9	3-P	0,004	0,3	2094 103	2094 103o
12,5 - 16	0,002	62	0,5	3-P	0,004	0,3	2095 104	2095 104o
16 - 20	0,002	62	0,5	3-P	0,004	0,5	2095 106	2095 106o
20 - 25	0,005	66	0,5	3-P	0,004	0,5	2095 107	2095 107o
25 - 35	0,005	66	0,5	3-P	0,004	0,5	2095 109	2095 109o
35 - 50	0,005	80	0,5	3-P	0,004	1,1	2095 111	2095 111o
50 - 65	0,005	80	0,5	3-P	0,005	1,1	2095 113	2095 113o
65 - 80	0,005	80	0,5	3-P	0,005	1,1	2095 114	2095 114o
80 - 100	0,005	100	0,5	3-P	0,005	1,2	2095 115	2095 115o
100 - 125	0,005	115	0,2	3-P	0,006	2,1	2095 116	2095 116o
125 - 150	0,005	115	0,2	3-P	0,006	2,7	2095 117	2095 117o
150 - 175	0,005	115	0,2	3-P	0,007	3,5	2095 118	2095 118o
175 - 200	0,005	115	0,2	3-P	0,007	3,8	2095 119	2095 119o
200 - 225	0,005	115	0,2	3-P	0,008	3,8	2095 120	2095 120o
225 - 250	0,005	115	0,2	3-P	0,008	3,8	2095 121	2095 121o
250 - 275	0,005	115	0,2	3-P	0,009	3,8	2095 122	2095 122o
275 - 300	0,005	115	0,2	3-P	0,009	3,8	2095 123	2095 123o

Sätze im Holzetui inkl. Einstellringe / Sets in wooden box incl. setting rings

2 - 3	0,001	9	1,9	2-P	0,004	2,0	2094 199
3 - 6	0,001	12 / 18	1,9	2-P	0,004	2,0	2094 200
6 - 10	0,002	58	1,9	3-P	0,004	2,0	2094 201
10 - 20	0,002	58 / 62	1,9 / 0,5	3-P	0,004	2,0	2095 202
20 - 50	0,005	66 / 80	0,5	3-P	0,004	3,2	2095 203
50 - 100	0,005	80 / 100	0,5	3-P	0,005	5,0	2095 204
100 - 150	0,005	115	0,5	3-P	0,006	7,0	2095 205
150 - 200	0,005	115	0,5	3-P	0,007	12,0	2095 206

## Verlängerungen für Innenmessschrauben



- ▶ passend für Modelle  
Nr. 2094... / 2095... / 2501... / 2502... / 2510...
- ▶ Lieferung einzeln verpackt

für / for mm	mm	kg	Nº
6 - 10	63	0,1	2096 101
10 - 12,5	76	2,0	2096 102
12,5 - 20	100	0,2	2096 103

## Extensions for internal micrometers

- ▶ Suitable for model  
No. 2094... / 2095... / 2501... / 2502... / 2510...
- ▶ Delivered in individual packages

für / for mm	mm	kg	Nº
20 - 50	150	0,45	2096 104
50 - 300	150	0,7	2096 105



**BOWERS GROUP**

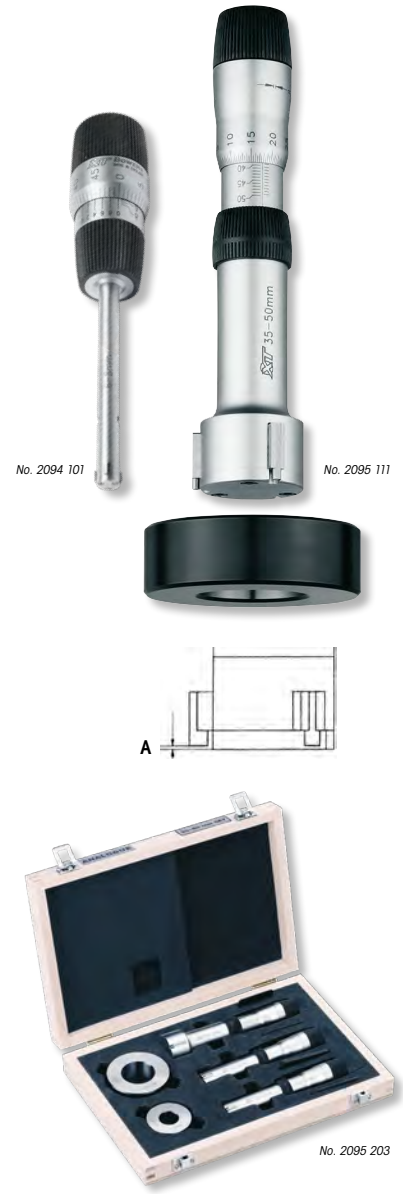

No. 2094 101

No. 2095 111

A

No. 2095 203



No. 2096 102

## Digital-Golitest-Innenmessschrauben

## Digital Golitest internal micrometers



- ▶ DIN 863
- ▶ besonders hohe Genauigkeit
- ▶ Schutzart IP 67
- ▶ großes LCD Display (hochkontrast)
- ▶ Hartmetallmessflächen
- ▶ Durchgangs- und Sacklochbohrungen
- ▶ kräftige Ratsche (selbstzentrierend)
- ▶ Lieferung im Koffer inkl. Werkskalibrierschein

### Funktionen:

- ▶ Auto-On bei Bewegung
- ▶ mm/inch Umschaltung
- ▶ 0-Punkt an jeder Position
- ▶ ± Preset Funktion
- ▶ Hold Funktion
- ▶ Datenausgang Opto, Datenübertragung per Knopfdruck

! größere Messbereiche und Messtiefen auf Anfrage

- ▶ DIN 863
- ▶ Extra high accuracy
- ▶ Protection class IP 67
- ▶ Large LCD display (high contrast)
- ▶ Tungsten carbide-tipped measuring faces
- ▶ Through bores and blind bores
- ▶ Sturdy ratchet (self centering)
- ▶ Delivered in a box incl. works calibration certificate

### Functions:

- ▶ Auto-on by sliding
- ▶ mm/inch commutation
- ▶ Zero setting at any position
- ▶ ± Preset function
- ▶ Hold function
- ▶ Data output Opto, data communication through button

! Larger measuring ranges and measuring depths on request

mm	inch	mm	inch	LJ mm	mm	kg	Nº
30 - 40	1,18 - 1,57	0,001	.00005	110	0,002	0,4	2600 101
40 - 60	1,57 - 2,36	0,001	.00005	110	0,002	0,4	2600 102
60 - 90	2,36 - 3,54	0,001	.00005	110	0,002	0,45	2600 103
90 - 140	3,54 - 5,51	0,001	.00005	110	0,002	0,6	2600 104
140 - 240	5,51 - 9,45	0,001	.00005	160	0,003	0,8	2600 105
240 - 400	9,45 - 15,75	0,001	.00005	210	0,003	1,3	2600 106

Sätze im Koffer, inkl. Verlängerung und Einstellringe, Sets in box incl. extension and setting rings

mm	inch	mm	inch	LJ mm	mm	kg	Nº
30 - 90	1,18-3,54	0,001	.00005	50 / 110	0,002	7,5	2600 201
90 - 400	3,54-15,75	0,001	.00005	110 / 160 / 210	0,002	11,9	2600 202
30 - 400	1,18-15,75	0,001	.00005	50 / 110 / 160 / 210	0,002	19,3	2600 203

Kontrolllehre für Ø40 - 240mm / Setting gauges for Ø40 - 240mm

2099 102

Kontrolllehre für Ø400mm / Setting gauges for Ø400mm

2099 103



No. 2600 104



No. 2099 1.

No. 2600 2.

## Golitest-Innenmessschrauben

## Golitest internal micrometers



- ▶ DIN 863
- ▶ besonders hohe Genauigkeit
- ▶ Ablesung parallaxfrei
- ▶ Ableseteile mattverchromt
- ▶ Hartmetallmessflächen
- ▶ Durchgangs- und Sacklochbohrungen
- ▶ kräftige Ratsche
- ▶ Lieferung im Holzetui inkl. Werkskalibrierschein

! größere Messbereiche und Messtiefen auf Anfrage.

- ▶ DIN 863
- ▶ Extra high accuracy
- ▶ Parallax free reading
- ▶ Satin chrome reading parts
- ▶ Tungsten carbide-tipped measuring faces
- ▶ Through bores and blind bores
- ▶ Sturdy ratchet
- ▶ Delivered in a wooden box incl. works calibration certificate

! Larger measuring ranges and measuring depths on request.

mm	mm	LJ mm	mm	kg	Nº
30 - 40	0,001	110	0,002	0,4	2097 101
40 - 60	0,001	110	0,002	0,46	2097 102
60 - 90	0,001	110	0,002	0,5	2097 103
90 - 140	0,001	140	0,002	0,55	2097 104
140 - 240	0,001	210	0,003	0,75	2097 105
240 - 400	0,001	300	0,003	1,25	2097 106
400 - 650	0,001	520	0,005	5,55	2097 107
650 - 900	0,001	520	0,007	6,3	2097 108
900 - 1150	0,001	520	0,008	7,3	2097 109

Sätze im Holzetui, inkl. Verlängerung, Einstellringe oder Kontrolllehre  
Sets in wooden box incl. extension, setting rings or setting gauge

mm	mm	LJ mm	mm	kg	Nº
30 - 90	0,001	110	0,0015	5,28	2097 201
90 - 400	0,001	140 / 220 / 300	0,0015	14,2	2097 202
30 - 400	0,001	140 / 220 / 300	0,0015	15,1	2097 203

Kontrolllehre für Ø40 - 240mm / Setting gauges for Ø40 - 240mm

2099 102

Kontrolllehre für Ø400mm / Setting gauges for Ø400mm

2099 103



No. 2097 104



No. 2099 1.

No. 2097 203

## Innenmessschrauben STANDARD

## Internal micrometers, STANDARD



TOP



Hartmetall  
Tungsten carbide

- ▶ Werksnorm
- ▶ Ableseteile mattverchromt
- ▶ Hartmetallmessflächen
- ▶ Spindelsteigung 0,5mm
- ▶ kräftige Ratsche
- ▶ Lieferung im Etui ohne Einstellringe

- ▶ Works standard
- ▶ Satin chrome reading parts
- ▶ Tungsten carbide-tipped measuring faces
- ▶ Spindle pitch 0.5mm
- ▶ Sturdy ratchet
- ▶ Delivered in a case without setting rings

mm	<math>\leq</math> mm	L mm	A mm	mm	kg	Nº
3,5 – 4,0	0,001	20	1,3	0,004	0,2	5020 101
4,0 – 4,5	0,001	20	1,3	0,004	0,2	5020 102
4,5 – 5,5	0,001	20	1,3	0,004	0,2	5020 103
5,5 – 6,5	0,001	20	1,3	0,004	0,2	5020 104
6 – 8	0,001	50	1,5	0,004	0,2	5020 105
8 – 10	0,001	50	1,5	0,004	0,3	5020 106
10 – 12	0,001	50	1,5	0,004	0,3	5020 107
12 – 16	0,005	60	1,0	0,004	0,3	5020 108
16 – 20	0,005	60	1,0	0,004	0,3	5020 109
20 – 25	0,005	80	1,0	0,004	0,5	5020 110
25 – 30	0,005	80	1,0	0,004	0,5	5020 111
30 – 35	0,005	80	1,0	0,004	0,5	5020 112
35 – 40	0,005	80	1,0	0,004	0,5	5020 113
40 – 50	0,005	90	1,0	0,006	1,1	5020 114
50 – 60	0,005	90	1,0	0,006	1,1	5020 115
60 – 70	0,005	90	1,0	0,006	1,1	5020 116
70 – 80	0,005	90	1,0	0,006	1,1	5020 117
80 – 90	0,005	90	1,0	0,006	1,1	5020 118
90 – 100	0,005	90	1,0	0,006	1,2	5020 119
100 – 125	0,005	140	16 / 1,0	0,010	2,1	5020 120
125 – 150	0,005	140	16 / 1,0	0,010	2,4	5020 121
150 – 175	0,005	140	16 / 1,0	0,010	2,7	5020 122
175 – 200	0,005	140	16 / 1,0	0,010	3,4	5020 123
200 – 225	0,005	140	16 / 1,0	0,020	5,2	5020 124
225 – 250	0,005	140	16 / 1,0	0,020	5,7	5020 125
250 – 275	0,005	140	16 / 1,0	0,020	5,8	5020 126
275 – 300	0,005	140	16 / 1,0	0,020	5,9	5020 127

Sätze im Holzetui inkl. Einstellringe und Verlängerungen / Sets in wooden box incl. setting rings and extensions

3,5 – 6,5	0,001	20	1,3	0,004	0,8	5023 101
6 – 12	0,001	50 (+100)	1,5	0,004	0,7	5023 102
12 – 20	0,005	60 (+150)	1,0	0,004	1,0	5023 103
20 – 40	0,005	80 (+150)	1,0	0,004	3,0	5023 104
40 – 100	0,005	90 (+150)	1,0	0,006	11,4	5023 105



No. 5020 110



No. 5020 118

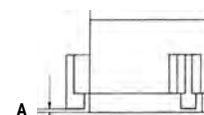

No. 5023 105

## Innenmessschrauben STANDARD

## Internal micrometers, STANDARD



Hartmetall  
Tungsten carbide

- ▶ Werksnorm
- ▶ Ablesung parallaxfrei
- ▶ Ableseteile mattverchromt
- ▶ Hartmetallmessflächen
- ▶ Durchgangs- und Sacklochbohrungen
- ▶ kräftige Ratsche
- ▶ Lieferung im Holzetui, inkl. Einstellringe (nicht Nr. 2500 105)

- ▶ Works standard
- ▶ Parallax free reading
- ▶ Satin chrome reading parts
- ▶ Tungsten carbide-tipped measuring faces
- ▶ Through bores and blind bores
- ▶ Sturdy ratchet
- ▶ Delivered in a wooden box incl. setting rings (not No. 2500 105)

mm	<math>\leq</math> mm	L mm	mm	kg	Nº
50 – 70	0,001	152	0,004	1,0	2500 101
70 – 100	0,001	152	0,004	1,1	2500 102
100 – 150	0,001	152	0,005	2,1	2500 103
150 – 250	0,001	152	0,007	2,7	2500 104
200 – 300	0,001	152	0,007	3,2	2500 105

No. 2500 101



# 14

## Drehzahlmessgeräte

Tachometers

## Zähler

Counters

## Thermometer

Thermometers

## Stoppuhren

Stop watches

## Härteprüfer

Hardness testers

## Prüfgeräte

Test instruments



★ **NEW**

Digital-Sekunden-thermometer  
Digital quick response thermometers



14.8

Digital-Härteprüfer  
Digital hardness testers



14.10

Rauheitsmessgerät POCKET  
Surface roughness testers POCKET



14.13

Digitale Shore Härteprüfgeräte  
Digital shore hardness testers



14.13

## Digital-Handtachometer

## Digital hand tachometers



- ▶ berührungslose (optische) Messung mit Reflexmarke, Distanz 350mm, Drehzahl in beide Drehrichtungen
- ▶ mechanische Messung mit aufsteckbaren Kontakten, Drehzahl, Geschwindigkeit und Länge in beide Drehrichtungen
- ▶ Reaktionszeit 0,5 sec.
- ▶ ABS Gehäuse

- ▶ Contact-free (optical) measurement with reflective tape, distance 350mm, Rev speed in both directions
- ▶ Mechanical measuring with detachable contact points, Rev speed, surface speed and length measurements in both directions
- ▶ Response time 0.5 sec.
- ▶ ABS housing

### 2100 101 :

Digital-Handtachometer optisch  
Lieferung im Koffer inkl. Reflexmarken und Batterien

#### Funktionen:

- Speicherfunktion Min, Max, AV
- Auto OFF

### 2101 101 :

Digital-Handtachometer optisch und mechanisch  
Lieferung im Koffer inkl. Messspitze,  
Messrad 6", Reflexmarken, Batterien

#### Funktionen:

- Speicherfunktion Min, Max, AV
- Umschaltung  
rpm, m/min, ft/min, in/min, m/sec, ft/sec, m, ft, in
- Auto OFF

### 2101 501 :

wie Nr. 2101 101,  
zusätzlich mit Fadenmessadapter

### 2100 210 :

10 Stück Reflexmarken

### 2100 215 :

Messspitzen

### 2100 216 :

Hohlkegel

### 2100 217 :

Messrad 0,1m

### 2100 218 :

Messrad 6"

### 2100 219 :

Messrad 12"

### 2100 220 :

Verlängerung

### 2100 101 :

Digital hand tachometers optical  
Delivered in a box incl. reflective tapes and batterie

#### Funktionen:

- Memory Min, Max, AV
- Auto OFF

### 2101 101 :

Digital hand tachometers optical and mechanical  
Delivered in a box incl. measuring points,  
measuring wheel 6", reflective tapes and batteries

#### Funktionen:

- Memory Min, Max, AV
- Commutation  
rpm, m/min, ft/min, in/min, m/sec, ft/sec, m, ft, in
- Auto OFF

### 2101 501 :

Same as No. 2101 101  
in addition to yarn measuring adapter

### 2100 210 :

10 pieces of reflective tapes

### 2100 215 :

Measuring points

### 2100 216 :

Hollow cone

### 2100 217 :

Measuring wheel 0.1m

### 2100 218 :

Measuring wheel 6"

### 2100 219 :

Measuring wheel 12"

### 2100 220 :

Extension



No. 2100 101



No. 2101 101



No. 2101 501



Koffer enthält Zubehör  
Box contents accessoires

☞ optisch / optical		☞ mechanisch / mechanical		Ⓜ	⚖ kg	Nº	Nº
Umdrehung Rotation	Umdrehung Rotation	Geschwindigkeit Speed	Länge Length				
1 – 99999 1/min / rpm	-	-	-	± 0,2% (1Digit)	0,25	2100 101	-
1 – 99999 1/min / rpm	1 – 19999 1/min / rpm	0,1 – 1999 m/min 0,4 – 6550 ft/min 4 – 78700 in/min	0 – 99999 m 0 – 99999 ft 0 – 99999 in	± 0,2% (1Digit)	0,25	2101 101	2101 501



No. 2100 210



No. 2100 215

No. 2100 216



No. 2100 217 / ... 218 / ... 219



No. 2100 220



## Handstroboskop



- ▶ Beobachten von schnellen gleichförmigen Bewegungen, die aufgrund der hohen Geschwindigkeit nicht sichtbar sind
- ▶ berührungslose Messung von Drehzahl, Wiederholrate oder Frequenz
- ▶ ca. 800Lux bei 20cm Entfernung
- ▶ großes LCD Matrix Display
- ▶ Xenon-Blitzröhre 10W
- ▶ ABS Gehäuse, mit Akku (NiMH)
- ▶ Lieferung im Koffer inkl. Akku, Ladegerät mit 4x Länderstecker (100-240V), Triggerstecker

### Funktionen:

- ▶ dynamische Frequenzeinstellung
- ▶ Triggereingang

fpm = Blitze pro Minute

fpm	<- fpm	Blitzzeit / Flash time 1/1000 sec.	± %	kg	Nº
30 - 12500	1	<20	± 0,01% (±1Digit)	0,46	2106 101
Ersatz-Blitzröhre / Spare flash tube					2106 202
Gürteltasche / Soft bag					2106 203

## Handstroboskop

- ▶ To keep track of fast uniform movements that are not visible due to the high velocity
- ▶ Contact-free measuring of rpm, repeat rate or frequency
- ▶ Approx. 800lux at 20cm distance
- ▶ Large LCD Matrix display
- ▶ Xenon flash tube 10W
- ▶ ABS housing with rechargeable battery (NiMH)
- ▶ Delivered in box incl. rechargeable battery, charger and 4x plugs (100-240V), trigger plug

### Functions:

- ▶ dynamic frequency adjustment
- ▶ Trigger input

fpm = flashes per minute.



No. 2106 101



No. 2106 203

## Handtachometer UNIVERSAL



- ▶ Drehzahl und Geschwindigkeit in beiden Drehrichtungen
- ▶ mechanische Messung mit aufsteckbaren Kontakten
- ▶ Wirbelstromprinzip mit 3 Messstufen
- ▶ Anzeigewertspeicher, Rückstellung mit Druckknopf
- ▶ ABS Gehäuse, 135x75x32mm, Uhr Ø 70mm
- ▶ Lieferung im Etui inkl. Messspitze, Hohlkegel und Messrad 0,1m

- ▶ Rev speed and surface speed in both directions
- ▶ Mechanical measuring with detachable contacts
- ▶ Eddy current principle with 3 measuring steps
- ▶ Display value memory, reset with push button
- ▶ ABS housing, 135x75x32mm, dial Ø 70mm
- ▶ Delivered in a case incl. measuring points, hollow cone and measuring wheel 0.1m

Stufe Step	fpm 1/min	m/min	± %	kg	Nº
I	40 - 500	4 - 50	± 0,5%	0,3	2113 101
II	400 - 5000	40 - 500			
III	4000 - 50000	400 - 5000			



No. 2113 101

## Handtounenzähler



- ▶ Drehzahl in beiden Drehrichtungen
- ▶ mechanische Messung mit aufsteckbarer Kontaktspitze
- ▶ ABS Gehäuse
- ▶ Lieferung im Etui inkl. Messspitze

- ▶ Rev speed in both directions
- ▶ Mechanical measuring with detachable contact points
- ▶ ABS housing
- ▶ Delivered in a case incl. measuring points

fpm 1/min / rpm	Ziffern Digits	Zifferhöhe / Digit height mm	kg	Nº
max. 6000	4	4,5	0,09	2114 101



No. 2114 101

## Hand-Stückzähler



- ▶ Nullstellung durch Drehknopf
- ▶ Personenzählung oder Stückzählung bis 9999
- ▶ ABS Gehäuse, Grundplatte Metall
- ▶ Lieferung einzeln verpackt

- ▶ Zero setting with turning knob
- ▶ For counting number of persons or pieces up to 9999
- ▶ ABS housing, base plate metal
- ▶ Delivered in individual packages

Typ / Type	Ziffern Digits	Zifferhöhe / Digit height mm	L. Ø mm	kg	Nº
mit Kette / With chain	4	4,5	55	0,07	2116 101
mit Ring / With ring	4	4,5	55	0,07	2116 102
mit Ring / With ring	4	4,5	55	0,06	2116 102s



No. 2116 102

No. 2116 102s

## Umdrehungszähler

## Revolution counters



- ▶ Nullstellung durch Drehknopf
- ▶ In einer Richtung addierend, bei Rückwärtsdrehung subtrahierend
- ▶ ABS Gehäuse, Montageplatte Stahl
- ▶ Lieferung einzeln verpackt

- ▶ Zero setting with turning knob
- ▶ Addition in one direction, subtraction with reverse turn
- ▶ ABS housing, mounting plate steel
- ▶ Delivered in individual packages

2115 1.. / 2115 3.. :

↻ im Uhrzeigersinn

2115 1.. / 2115 3.. :

↻ Clockwise

2115 2.. / 2115 4.. :

↻ gegen Uhrzeigersinn

2115 2.. / 2115 4.. :

↻ Anticlockwise



max. 1/min / rpm	Ziffern Digits	Ziffernhöhe / Digit height mm	Wellen / Shaft Ø mm	L mm	E mm	kg	↻ N°	↻ N°
Antrieb rechts / Right drive								
2000	5	4,5	4,0	40 x 46	27,5	0,09	2115 103	2115 203
2000	5	4,5	4,0	60 x 29	27,5	0,09	2115 105	2115 205
Antrieb links / Left drive								
2000	5	4,5	4,0	40 x 46	27,5	0,09	2115 303	2115 403
2000	5	4,5	4,0	60 x 29	27,5	0,09	2115 305	2115 405

## Umdrehungszähler

## Revolution counters



- ▶ Nullstellung durch abziehbaren Schlüssel
- ▶ In einer Richtung addierend, bei Rückwärtsdrehung subtrahierend
- ▶ ABS Gehäuse, Montageplatte Stahl
- ▶ Lieferung einzeln verpackt

- ▶ Zero setting with detachable key
- ▶ Addition in one direction, subtraction with reverse turn
- ▶ ABS housing, mounting plate steel
- ▶ Delivered in individual packages

2115 1.. / 2115 3.. :

↻ im Uhrzeigersinn

2115 1.. / 2115 3.. :

↻ Clockwise

2115 2.. / 2115 4.. :

↻ gegen Uhrzeigersinn

2115 2.. / 2115 4.. :

↻ Anticlockwise



max. 1/min / rpm	Ziffern Digits	Ziffernhöhe / Digit height mm	Wellen / Shaft Ø mm	L mm	E mm	kg	↻ N°	↻ N°
Antrieb rechts und links / Right and left drives								
3000	6	4,5	4,0	60 x 70	28	0,18	2115 106	2115 206
1000	7	7	7,0	120 x 64	45	0,35	2115 306	2115 406

## Umdrehungszähler

## Revolution counters



- ▶ Nullstellung durch Hebel
- ▶ Hebel links oder rechts einsteckbar
- ▶ ABS Gehäuse, Montageplatte Stahl
- ▶ Lieferung einzeln verpackt

- ▶ Zero setting with lever
- ▶ Lever pluggable at left or right
- ▶ ABS housing, mounting plate steel
- ▶ Delivered in individual packages

2115 1.. :

↻ im Uhrzeigersinn

2115 1.. :

↻ Clockwise

2115 2.. :

↻ gegen Uhrzeigersinn

2115 2.. :

↻ Anticlockwise

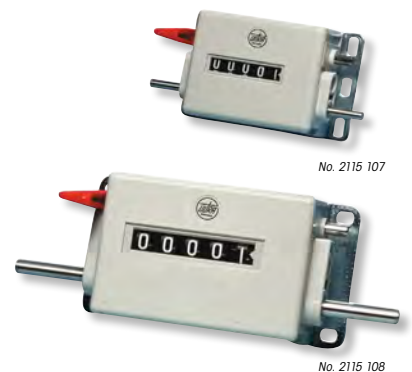

max. 1/min. / rpm	Ziffern Digits	Ziffernhöhe / Digit height mm	Wellen / Shaft Ø mm	L mm	E mm	kg	↻ N°	↻ N°
Antrieb rechts und links / Right and left drives								
3000	5	4,5	4,0	80 x 48	28	0,18	2115 107	2115 207
3000	5	7	7,0	120 x 64	45	0,35	2115 108	2115 208

## Hubzähler

## Stroke counters



- ▶ Nullstellung durch Drehknopf
- ▶ In einer Richtung addierend
- ▶ Hubhebel verstellbar
- ▶ Hub min. 38°, max. 60°
- ▶ ABS Gehäuse, Montageplatte Stahl
- ▶ Lieferung einzeln verpackt

- ▶ Zero setting with turning knob
- ▶ Addition in one direction
- ▶ Adjustable stroke lever
- ▶ Stroke min. 38°, max. 60°
- ▶ ABS housing, mounting plate steel
- ▶ Delivered in individual packages

2117 1.. / 2117 3.. :

↻ im Uhrzeigersinn

2117 1.. / 2117 3.. :

↻ Clockwise

2117 2.. / 2117 4.. :

↻ gegen Uhrzeigersinn

2117 2.. / 2117 4.. :

↻ Anticlockwise



max. 1/min / rpm	Ziffern Digits	Ziffernhöhe / Digit height mm	Wellen / Shaft Ø mm	L mm	l mm	h kg	↻ Nº	↻ Nº
Antrieb rechts / Right drive								
500	5	4,5	4,0	40 x 46	27,5	0,09	2117 102	2117 202
500	5	4,5	4,0	60 x 29	27,5	0,09	2117 104	2117 204
Antrieb links / Left drive								
500	5	4,5	4,0	40 x 46	27,5	0,09	2117 302	2117 402
500	5	4,5	4,0	60 x 29	27,5	0,09	-	2117 404

## Hubzähler

## Stroke counters



- ▶ Nullstellung durch abziehbaren Schlüssel
- ▶ In einer Hubrichtung addierend
- ▶ Hubhebel verstellbar
- ▶ Hub min. 38°, max. 60°
- ▶ ABS Gehäuse, Montageplatte Stahl
- ▶ Lieferung einzeln verpackt

- ▶ Zero setting with detachable key
- ▶ Addition in one stroke direction
- ▶ Adjustable stroke lever
- ▶ Stroke min. 38°, max. 60°
- ▶ ABS housing, mounting plate steel
- ▶ Delivered in individual packages

2117 1.. :

↻ im Uhrzeigersinn

2117 1.. :

↻ Clockwise

2117 2.. :

↻ gegen Uhrzeigersinn

2117 2.. :

↻ Anticlockwise



max. 1/min / rpm	Ziffern Digits	Ziffernhöhe / Digit height mm	Wellen / Shaft Ø mm	L mm	l mm	h kg	↻ Nº	↻ Nº
Antrieb rechts und links / Right and left drives								
500	6	4,5	4,0	60 x 70	28	0,13	2117 105	2117 205
500	7	7	7,0	120 x 64	45	0,35	2117 106	2117 206

## Hubzähler

## Stroke counters



- ▶ Nullstellung durch Hebel
- ▶ Hebel links und rechts einsteckbar
- ▶ In einer Hubrichtung addierend.
- ▶ Hubhebel verstellbar
- ▶ Hub min. 38°, max. 60°
- ▶ ABS Gehäuse, Montageplatte Stahl
- ▶ Lieferung einzeln verpackt

- ▶ Zero setting with lever
- ▶ Lever pluggable at left or right
- ▶ Addition in one stroke direction
- ▶ Adjustable stroke lever
- ▶ Stroke min. 38°, max. 60°
- ▶ ABS housing, mounting plate steel
- ▶ Delivered in individual packages

2117 1.. :

↻ im Uhrzeigersinn

2117 1.. :

↻ Clockwise

2117 2.. :

↻ gegen Uhrzeigersinn

2117 2.. :

↻ Anticlockwise



max. 1/min / rpm	Ziffern Digits	Ziffernhöhe / Digit height mm	Wellen / Shaft Ø mm	L mm	l mm	h kg	↻ Nº	↻ Nº
Antrieb rechts und links / Right and left drives								
500	5	4,5	4,0	80 x 48	28	0,13	2117 107	2117 207
500	5	7	7,0	120 x 64	45	0,38	2117 108	2117 208

## Meterzähler

## Measuring counters



- ▶ Nullstellung durch abziehbaren Schlüssel
- ▶ in einer Drehrichtung addierend, bei Rückwärtsdrehung subtrahierend
- ▶ ABS Gehäuse, Montageplatte Stahl
- ▶ Lieferung einzeln verpackt, ohne Messrad

- ▶ Zero setting with detachable key
- ▶ Addition in one direction, subtraction with reverse turn
- ▶ ABS housing, mounting plate steel
- ▶ Delivered in individual packages without measuring wheel

2119 1.. :

↻ im Uhrzeigersinn

2119 1.. :

↻ Clockwise

2119 2.. :

↻ gegen Uhrzeigersinn

2119 2.. :

↻ Anticlockwise



No. 2119 102

No. 2119 104

max. m / min.	mm m	Ziffern Digits	Ziffernhöhe / Digit height mm	Wellen / Shaft Ø mm	L mm	E mm	kg	↻ N°	↻ N°
Antrieb rechts und links / Right and left drives									
100	99999,9	6	4,5	4,0	60 x 70	28	0,13	2119 102	2119 202
100	999999,9	7	7	7,0	120 x 64	45	0,35	2119 104	2119 204

## Meterzähler

## Measuring counters



- ▶ Nullstellung durch Hebel
- ▶ Hebel links oder rechts einsteckbar
- ▶ in einer Drehrichtung addierend, bei Rückwärtsdrehung subtrahierend
- ▶ ABS Gehäuse, Montageplatte Stahl
- ▶ Lieferung einzeln verpackt, ohne Messrad

- ▶ Zero setting with lever
- ▶ Lever pluggable at left or right
- ▶ Addition in one direction, subtraction with reverse turn
- ▶ ABS housing, mounting plate steel
- ▶ Delivered in individual packages without measuring wheel

2119 1.. :

↻ im Uhrzeigersinn

2119 1.. :

↻ Clockwise

2119 2.. :

↻ gegen Uhrzeigersinn

2119 2.. :

↻ Anticlockwise



No. 2119 101

No. 2119 103

max. m / min.	mm m	Ziffern Digits	Ziffernhöhe / Digit height mm	Wellen / Shaft Ø mm	L mm	E mm	kg	↻ N°	↻ N°
Antrieb rechts und links / Right and left drives									
200	9999,9	5	4,5	4,0	80 x 48	28	0,13	2119 101	2119 201
300	9999,9	5	7	7,0	120 x 64	45	0,38	2119 103	2119 203

## Messräder für Meterzähler

## Measuring wheels for measuring counters



- ! Wellen-Ø am Meterzähler beachten!  
Andere Beläge, Gummi glatt oder genoppt auf Anfrage.

- ! Note the shaft Ø on the measuring counter!  
Other coatings, rubber flat or knobbed on request.

Typ Type	für Wellen for shaft Ø mm	L mm	Umfang Circumference cm	kg	N°
Aluminium – Kreuzrändel Aluminium – axial and circum. knurl	4	12	20	0,04	2120 101
Kunststoff – glatt Plastic – smooth	4	12	20	0,04	2120 103
Kunststoff – geriffelt Plastic – corrugated	4	12	20	0,04	2120 104
Noppengummi Knopped rubber	4	12	20	0,04	2120 105
Aluminium – Kreuzrändel Aluminium – axial and circum. knurl	7	25	50	0,35	2120 201
Kunststoff – glatt Plastic – smooth	7	25	50	0,26	2120 203
Kunststoff – geriffelt Plastic – corrugated	7	25	50	0,26	2120 204
Noppengummi Knopped rubber	7	25	50	0,26	2120 205



No. 2120 105  
No. 2120 205

No. 2120 101  
No. 2120 201

No. 2120 103  
No. 2120 203

No. 2120 104  
No. 2120 204

**Digital-Präzisionsthermometer für hochgenaue Kalibrierung**

**Digital thermometers for high precision calibration**



- ▶ Mikroprozessor gesteuert
- ▶ Pt100, 4-Leiter Messung
- ▶ Kennlinie nach DIN EN 60751
- ▶ LCD Display 2-zeilig
- ▶ Betriebstemperatur -25°C – +50°C
- ▶ Genauigkeit:  
≤ 0,03° bei 0,01°C (±199,99°C)  
± 0,1° bei 0,1°C (+200,0 ... +850,0°C)
- ▶ ABS Gehäuse
- ▶ Datenausgang seriell oder analog 0 – 1V
- ▶ Lieferung einzeln verpackt ohne Fühler

**Funktionen:**

- ▶ Anzeige °C oder °F
- ▶ Hold Funktion
- ▶ Nullpunkt- / Steigungseingabe
- ▶ Speicherfunktion Min / Max
- ▶ Auto OFF

! Andere Präzisionsfühler auf Anfrage.

- ▶ Microprocessor controlled
- ▶ Pt100, 4-wire measuring
- ▶ Characteristic according to DIN EN 60751
- ▶ Two-line LCD display
- ▶ Operating temperature -25°C – +50°C
- ▶ Accuracy:  
≤ 0.03° at 0.01°C (±199.99°C)  
± 0.1° at 0.1°C (+200.0 ... +850.0°C)
- ▶ ABS housing
- ▶ Serial or analogue 0 – 1V data output
- ▶ Delivered in individual packages without probe

**Functions:**

- ▶ Display °C or °F
- ▶ Hold function
- ▶ Zero-point / slope input
- ▶ Min. /Max. memory
- ▶ Auto OFF

! Other precision probes on request.

Temperaturbereich °C	Genauigkeit °C	Wärmeleitfähigkeit mm	Weg kg	Nº
-199,99 ... +199,99 -200,0 ... +850,0	0,01 0,1	142x71x26	0,155	2127 101
Präzisionsfühler für weichplastische Medien, Gase und Flüssigkeiten -50...+400°C 1/3 DIN (0-150°C) restlicher Bereich 1/2 DIN Precision probe for soft media, gases and liquids -50...+400°C 1/3 DIN (0-150°C) remaining range 1/2 DIN				2130 306



Koffer / Box	2121 301
Netzgerät / Mains adaptor	2122 302



No. 2127 101



No. 2121 301

**Infrarot Handthermometer mit Laservisier**

**Infrared hand held thermometers with laser sighting**



- ▶ Messung aus sicherer Entfernung durch Präzisionsglasoptik (Keine glänzenden oder polierten Oberflächen)
- ▶ LCD Display beleuchtet
- ▶ Betriebstemperatur 0 – 50°C
- ▶ Genauigkeit:  
± 1% oder ± 1°C (0°C...530°C)  
± 1°C ± 0,07°C/°C (-32°C...0°C)
- ▶ Reproduzierbarkeit:  
± 0,5% oder ± 0,7°C (0°C...530°C)  
± 0,7°C ± 0,05°C/°C (-32°C...0°C)
- ▶ Ansprechzeit 300ms (95% des Messwerts)
- ▶ ABS Gehäuse
- ▶ Lieferung in Tasche

**Funktionen:**

- ▶ Anzeige °C oder °F
- ▶ Emissionsgrad einstellbar 0,100 – 1,000
- ▶ Speicherfunktion Min / Max
- ▶ Hold Funktion
- ▶ Alarm bei Temperaturüberschreitung

- ▶ Measuring from safe distance with high performance optics (No glossy or polished surfaces)
- ▶ Illuminated LCD display
- ▶ Operating temperature 0 – 50°C
- ▶ Accuracy:  
± 1% or ± 1°C (0°C...530°C)  
± 1°C ± 0.07°C/°C (-32°C...0°C)
- ▶ Repeatability:  
± 0.5% or ± 0.7°C (0°C...530°C)  
± 0.7°C ± 0.05°C/°C (-32°C...0°C)
- ▶ Response time 300ms (95% of the measured value)
- ▶ ABS housing
- ▶ Delivered in a bag

**Functions:**

- ▶ Display °C or °F
- ▶ Adjustable emission ratio 0.100 – 1.000
- ▶ Min. / Max. memory function
- ▶ Hold function
- ▶ Alarm notification when temperature exceeds



No. 2125 101

Standardoptik 20:1  
Messpunkt Ø 13mm bis 0,14m  
Messpunkt Ø 50mm bei 1m

Standard optics 20:1  
Measuring point Ø 13mm up to 0.14m  
Measuring point Ø 50mm up to 1m

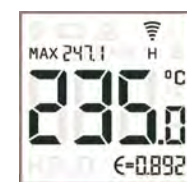

Optik Optics	Temperaturbereich °C	Genauigkeit °C	Wärmeleitfähigkeit mm	Weg kg	Nº
20:1	-32 ... +530	0,1	190x38x140	0,15	2125 101

## Digital-Sekundenthermometer STANDARD

## Digital quick response thermometers, STANDARD



★ NEW

- ▶ präzise Messungen an Oberflächen, weichplastische Medien, Gase und Flüssigkeiten
- ▶ LCD-Display
- ▶ Betriebstemperatur -25 °C ... +50 °C
- ▶ Genauigkeit:
  - ▶ ± 0,1 °C ± 1 Digit (im Bereich von -100,0 ... 200,0 °C)
  - ▶ sonst ± 0,1% v. MW ± 1 Digit
- ▶ ABS Gehäuse
- ▶ Lieferung einzeln verpackt ohne Fühler

### Funktionen:

- ▶ ON / Auto OFF, Anzeige °C oder °F, Hold Funktion, Akustische Temperaturgrenzüberwachung, Speicherfunktion Min / Max

- ▶ Precise measuring of surfaces, soft media, gases and liquids
- ▶ LCD display
- ▶ Operation temperature -25 °C ... +50 °C
- ▶ Accuracy:
  - ▶ ± 0,1 °C ± 1 Digit (between -100.0 ... 200.0 °C)
  - ▶ otherwise ± 0,1% of m. v. ± 1 Digit
- ▶ ABS housing
- ▶ Delivered in individual packages without probe

### Funktionen:

- ▶ ON / Auto OFF, Display °C or °F, Hold function, Acoustic temperature control, Min. / Max. memory

Temperaturbereich °C	Genauigkeit °C	Länge mm	Gewicht kg	Nr.
-200,0 ... +400,0	0,1	142x71x26	0,17	2121 202
Tauchfühler VA4 Rohr starr -70 ... +200 °C / Immersion probe VA4 pipe rigid -70 ... +200 °C				2130 501

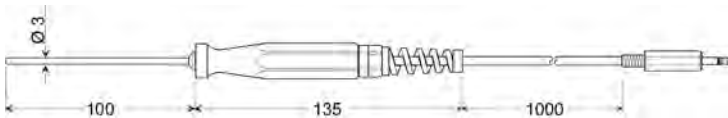

Luft-, Rohranlegefühler -50 ... +200 °C /  
Air-, tube mounting probe -50 ... +200 °C

2130 502

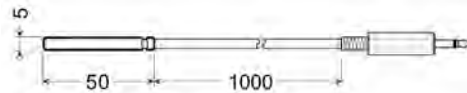

Koffer / Box

2121 302



No. 2121 202



No. 2130 502

## Digital-Präzisionsthermometer

## Digital precision thermometers



TOP

- ▶ für Wechselfühler NiCr-Ni Serie Nr. 2130 1...
- ▶ präzise Messungen an Oberflächen, weichplastische Medien, Gase und Flüssigkeiten
- ▶ LCD-Display 2-zeilig
- ▶ Betriebstemperatur -25 °C ... +50 °C
- ▶ Genauigkeit:
  - ▶ ± 0,03% vom Messwert ± 0,05% FS (-65,0 ... +300,0 °C)
  - ▶ ± 0,08% vom Messwert ± 0,1% FS (-220 ... +1370 °C)
- ▶ Datenausgang seriell
- ▶ Anschluss für Netzgerät
- ▶ ABS Gehäuse
- ▶ Lieferung einzeln verpackt ohne Fühler

### Funktionen:

- ▶ ON / Auto OFF, Anzeige °C oder °F, Hold Funktion, Nullpunkt- und Offseteingabe, Speicherfunktion Min. / Max., Messwertkorrektur für Oberflächenmessung

- ▶ For removable probe NiCr-Ni series No. 2130 1...
- ▶ Precise measuring of surfaces, soft media, gases and liquids
- ▶ Two-line LCD display
- ▶ Operating temperature -25 °C ... +50 °C
- ▶ Accuracy:
  - ▶ ± 0.03% of measured value ± 0.05% FS (-65.0 ... +300.0 °C)
  - ▶ ± 0.08% of measured value ± 0.1% FS (-220 ... +1370 °C)
- ▶ Serial data output
- ▶ Connection for mains adaptor
- ▶ ABS housing
- ▶ Delivered in individual packages without probe

### Funktionen:

- ▶ ON / Auto OFF, Display °C or °F, Hold function, Zero-point and offset entry, Min. / Max. memory, Measured value adjustment for surface measuring

2122 101:  
Datenausgang seriell oder analog 0-1V

2122 101:  
Serial or analogue 0-1V data output

2122 201:  
2 Fühler können gleichzeitig betrieben werden  
Differenzmessung Fühler 1 zu 2  
Nullpunkt setzen, Differenzwertanzeige Fühler 1 zu 2

2122 201:  
2 probes can be in operation at once  
Differential measuring of probe 1 and probe 2  
Zero setting, differential value display of probe 1 and probe 2

Temperaturbereich °C	Genauigkeit °C	Länge mm	Gewicht kg	Nr.	Nr.
-199,9 ... +999,9 -200 ... +1370	0,1 1	142x71x26	0,155	2122 101	2122 201
Koffer / Box				2121 301	
Netzgerät / Mains adaptor				2122 302	



No. 2122 101



No. 2121 301

**Temperaturfühler  
für Serie Nr. 2122...**

**Temperature probes  
for series No. 2122...**



- ▶ Wechselfühler NiCr-Ni Typ K
- ▶ Isoliergriff
- ▶ Silikonanschlusskabel 1m
- ▶ DIN Flachstecker
- ▶ Lieferung einzeln verpackt

- ▶ Removable probe NiCr-Ni Type K
- ▶ Insulated handle
- ▶ Silicon connection cable 1m
- ▶ DIN flat connection
- ▶ Delivered in individual packages

! Andere Spezialfühler sowie Thermoelementdrähte auf Anfrage.

! Other special probes and thermoelement wires on request.

Sec. = Ansprechgeschwindigkeit

Sec. = Response speed

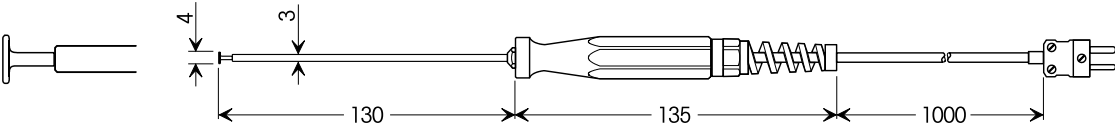
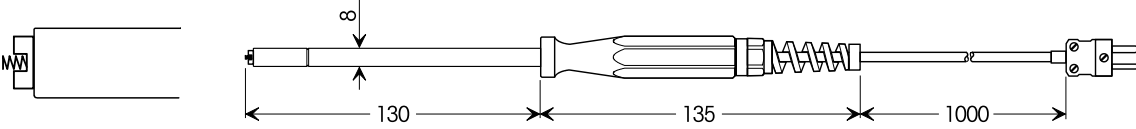
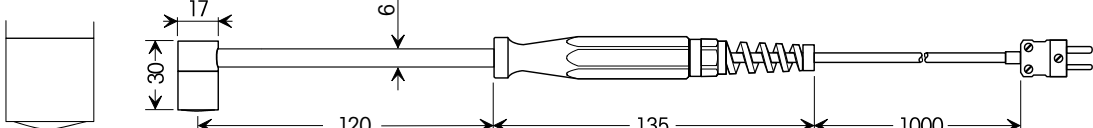
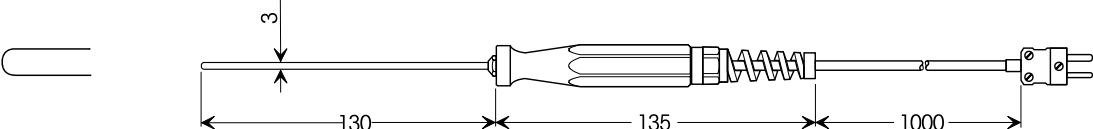
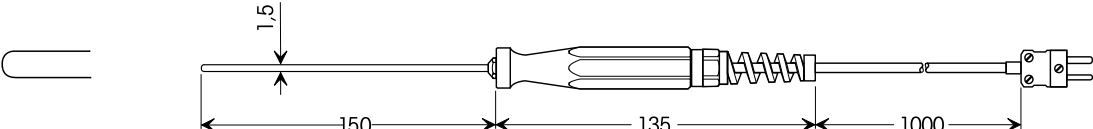
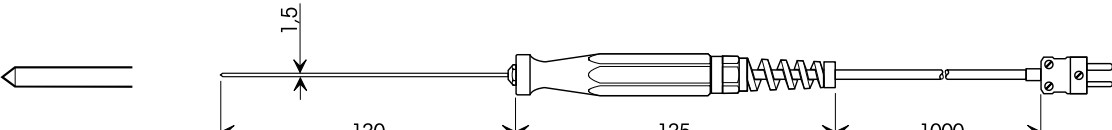
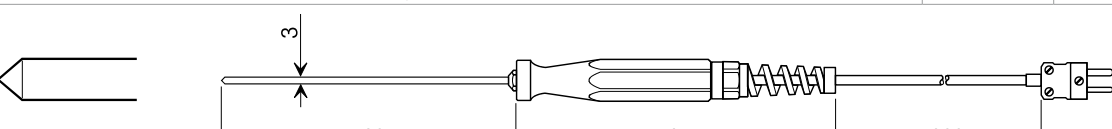
Typ Type	Temperaturbereich °C	Sec.	Nº
Oberflächenfühler Cu Plättchen / Surface probe Cu tips	-65 ... +500	3	2130 101
			
Oberflächenfühler NiCr-Ni Spiralfedern / Surface probe NiCr-Ni spiral springs	-65 ... +900	5	2130 102
			
Oberflächenfühler NiCr-Ni Plättchen 90° abgewinkelt / Surface probe NiCr-Ni tips 90° bent	-65 ... +400	2	2130 103
			
Tauchfühler V4A Rohr starr / Immersion probe V4A pipe rigid	-65 ... +1000	5	2130 104
			
Tauchfühler Inconel, potentialfrei / Immersion probe Inconel, potential free	-200 ... +1150	3	2130 105
			
Einstechfühler V4A Rohr federnd / Insertion probe V4A pipe springy	-65 ... +550	3	2130 106
			
Einstechfühler V4A Rohr starr / Insertion probe V4A pipe rigid	-65 ... +1000	5	2130 107
			

1  
2  
3  
4  
5  
6  
7  
8  
9  
10  
11  
12  
13  
14  
15

**Digital-Hygro- und Thermometer STANDARD Digital hygro and thermometers, STANDARD**



- ▶ schnelle Messungen der Luftfeuchte und Temperatur
- ▶ LCD-Display
- ▶ Betriebstemperatur -20°C ... +70°C
- ▶ Genauigkeit Temperatur: ± 0,5% vom Messwert ±0,1°C
- ▶ Genauigkeit Feuchte: ± 2% Linearität ±1,5°C Hysterese (empf. Messbereich 30 ... 80%)
- ▶ ABS Gehäuse
- ▶ Lieferung einzeln verpackt

- ▶ Quick measuring of air humidity and temperature
- ▶ LCD display
- ▶ Operating temperature -20°C ... +70°C
- ▶ Temperature accuracy: ± 0.5% of measured value ±0.1°C
- ▶ Humidity accuracy: ± 2% Linearity ±1.5°C hysteresis (Recommended measuring range 30 ... 80%)
- ▶ ABS housing
- ▶ Delivered in individual packages

- Funktionen:**
- ▶ ON / OFF
  - ▶ Anzeige °C oder % r.F.

- Functions:**
- ▶ ON/OFF
  - ▶ Display °C or % r.F.

Temperaturbereich °C	Genauigkeit °C	Abmessungen mm	Gewicht kg	Artikelnummer №
-20 ... +70 °C 10 ... 95 r.F.	0,1 °C 0,1 %	106x67x30	0,135	2128 101



No. 2128 101

**Digital-Härteprüfer HARTIP 3210 für kabellose Schlaggeräte Digital hardness testers HARTIP 3210 for wireless impact devices**



- ▶ Härteprüfung nach Leeb HL
- ▶ Anzeige HL / HRC / HRB / HB / HV / HS / HRA / ob
- ▶ mit kabellosem Schlaggerät D
- ▶ Funkreichweite ca. 10m
- ▶ Anwendung richtungsunabhängig
- ▶ großes LCD Farbdisplay
- ▶ Genauigkeit ±0,3 % bei HL 800
- ▶ Werkstückmasse min. 5 kg
- ▶ Lieferung im Etui inkl. kabellosem Schlaggerät D, Härtevergleichsplatte, Datenübertragungssoftware, USB-Dongle und USB-Kabel

- ▶ Hardness testing based on Leeb rebound principle
- ▶ Display of HL / HRC / HRB / HB / HV / HS / HRA / ob
- ▶ With wireless impact device D
- ▶ Range of radio transmission approximately 10m
- ▶ Application independent of directions
- ▶ Large color LCD display
- ▶ Accuracy ±0.3 % bei HL 800
- ▶ Workpiece weight min. 5 kg
- ▶ Delivered in a case incl. wireless impact device D, hardness comparison plate, data managing software, USB-Dongle and USB-Cable

- Funktionen:**
- ▶ ON / OFF Auto, Reset Funktion, Messwertspeicher 25000x, Datenausgang RS232

- Functions:**
- ▶ ON / OFF Auto, Reset Funktion, Measured value memory 25000x, Data output RS232

! Schlaggeräte mit Kabel für HARTIP 3000 können ebenfalls verwendet werden.

! Impact devices with cable for HARTIP 3000 are also suitable.

Temperaturbereich HL	Abmessungen mm	Gewicht kg	Artikelnummer №
170 ... 960 (~ 1,3 ... 78,2 HRC)	195x84x38	4,5	2144 203



No. 2144 203

**Kabellose Schlaggeräte für HARTIP 3210 Wireless impact devices for HARTIP 3210**



- ▶ Lieferung einzeln verpackt

- ▶ Delivery in individual packages

! Weitere Informationen siehe Gebrauchsanweisung.

! Further informations see operating manual.

Typ	Anwendung Application	Gewicht kg	Artikelnummer №
D	Universal Schlaggerät im Lieferumfang. Universal impact device supplied with the instrument.	0,075	2144 951
DC	Sehr kurze Bauform für schwer zugängliche Stellen. Very short impact device for use in very confined spaces.	0,05	2144 952
DL	Sehr dünne Prüfspitze (Dm. 2,78mm) für Nuten und Einstiche. Thin needle (Dia. 2,78mm) for slots and recesses.	0,08	2144 953
C	Schlagkörper mit verminderter Aufschlagenergie (ca. ¼ des D-Typs). Reduced impact energy for sensitive work pieces (approx. ¼ of D-Type).	0,075	2144 954
D+15	Sehr kleiner Kontaktbereich mit einer zurückverlegten Meßspule. Slim front section with moved back measuring coil.	0,25	2144 955





**Digital-Härteprüfer HARTIP 1500**

**Digital hardness testers HARTIP 1500**



- ▶ Härteprüfung nach Leeb HL
- ▶ Anzeige HL / HRC / HRB / HB / HV / HS
- ▶ integriertes Schlaggerät D
- ▶ Anwendung richtungsunabhängig
- ▶ LCD Display
- ▶ Genauigkeit ±0,6% bei HL 800
- ▶ Werkstückmasse min. 5 kg
- ▶ Lieferung im Etui inkl. Härtevergleichsplatte

- ▶ Hardness testing based on Leeb rebound principle
- ▶ Display of HL / HRC / HRB / HB / HV / HS
- ▶ Integrated impact device D
- ▶ Application independent of directions
- ▶ LCD display
- ▶ Accuracy ±0.6% at HL 800
- ▶ Workpiece weight min. 5kg
- ▶ Delivered in a case incl. hardness comparison plate

**Funktionen:**

- ▶ ON / OFF Auto, Reset Funktion, 9 Werkstoffgruppen, Messwertspeicher 99x

**Functions:**

- ▶ ON / OFF Auto, Reset function, 9 groups of materials, Measured value memory 99x



No. 2144 201

HL	mm	kg	Nº
200 ... 960 (~20 ... 67 HRc)	100x60x33	0,15	2144 201

**Digital-Härteprüfer HARTIP 3000**

**Digital hardness testers HARTIP 3000**



- ▶ Härteprüfung nach Leeb HL
- ▶ Anzeige HL / HRC / HRB / HB / HV / HS
- ▶ mit separatem Schlaggerät D
- ▶ Anwendung richtungsunabhängig
- ▶ LCD Display
- ▶ Genauigkeit ±0,5 % bei HL 800
- ▶ Werkstückmasse min. 5 kg
- ▶ Lieferung im Etui inkl. Schlaggerät D und Härtevergleichsplatte

- ▶ Hardness testing based on Leeb rebound principle
- ▶ Display of HL / HRC / HRB / HB / HV / HS
- ▶ With separate impact device D
- ▶ Application independent of directions
- ▶ LCD display
- ▶ Accuracy ±0.5 % at HL 800
- ▶ Workpiece weight min. 5 kg
- ▶ Delivered in a case incl. impact device D and hardness comparison plate

**Funktionen:**

- ▶ ON / OFF Auto, Reset Funktion, Messwertspeicher 960x in, Datenausgang RS232

**Functions:**

- ▶ ON/OFF Auto, Reset function, Measured value memory 960x in, Data output RS232



No. 2144 202

HL	mm	kg	Nº
200 ... 960 (~20 ... 67 HRc)	195x84x38	0,55	2144 202
Datenkabel RS232 (1m) / Data cable RS232 (1m)			2144 251
Datenübertragungssoftware / Data managing software			2144 261

**Schlaggeräte für HARTIP 3000/3210**

**Impact devices for HARTIP 3000/3210**



- ▶ Lieferung einzeln verpackt

- ▶ Delivery in individual packages

! Weitere Informationen siehe Gebrauchsanweisung.

! Further informations see operating manual.

Typ	Anwendung Application	kg	Nº
D	Universal Schlaggerät im Lieferumfang. Universal impact device supplied with the instrument.	0,075	2144 901
DC	Sehr kurze Bauform für schwer zugängliche Stellen. Very short impact device for use in very confined spaces.	0,05	2144 902
DL	Sehr dünne Prüfspitze (Dm. 2,78mm) für Nuten und Einsteiche. Thin needle (Dia. 2,78mm) for slots and recesses.	0,08	2144 903
C	Schlagkörper mit verminderter Aufschlagenergie (ca. ¼ des D-Typs). Reduced impact energy for sensitive work pieces (approx. ¼ of D-Type).	0,075	2144 904
D+15	Sehr kleiner Kontaktbereich mit einer zurückverlegten Meßspule. Slim front section with moved back measuring coil.	0,075	2144 905
G	Schlagkörper mit vergrößerter Prüfspitze und größerer Schlagenergie. Speziell für schwere Guß- und Schmiedeteilen, nur Brinell Härte (max. 650 HB). Impact device with enlarged test tip and increased impact energy. Special for heavy Cast and forged work pieces, only Brinell Hardness (max. 650 HB).	0,25	2144 906
E	Schlagkörper mit Diamant-Prüfspitze (circa 5000 HV). Speziell für extrem harte Teile wie Carbonstahl bis 1200 HV. Impact device with diamond test tip (approx. 5000 HV). Specially for extremely high hardness measurement such as high carbon steel up to 1200 HV.	0,1	2144 907

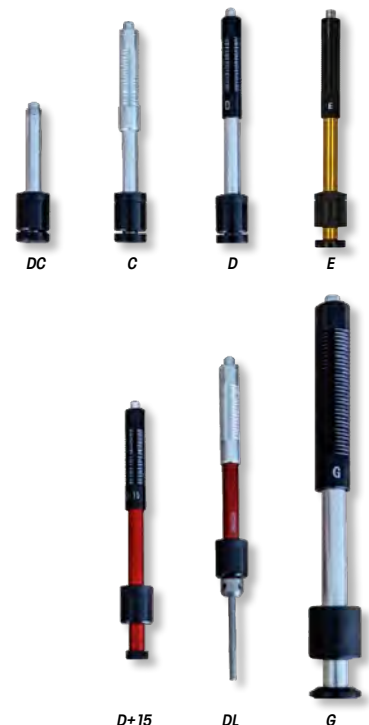

## Schlaghärteprüfer POLDI

## Impact hardness testers POLDI



- ▶ zum Bestimmen der Brinellhärte an Stahl, Bronze, Aluminium, Kupfer, Messing, Stahlguss
- ▶ Härte wird durch Messen des Eindruck Ø mit Hilfe der Vergleichstabelle bestimmt
- ▶ Werkstückmasse min. 5kg
- ▶ Materialstärke min. 6mm
- ▶ Lieferung im Etui inkl. Vergleichsstab, Messlupe und Vergleichstabelle

- ▶ For determining Brinell hardness of steel, bronze, aluminium, copper, brass and cast iron
- ▶ Hardness is determined by measuring the indentation Ø with the help of the comparison table
- ▶ Workpiece weight min. 5kg
- ▶ Material thickness min 6mm
- ▶ Delivered in a case incl. gauge bar, measuring magnifier and comparison table



No. 2139 101

kg	Nº
0,4	2139 101
Ersatz-Vergleichsstab, Querschnitt 12x12mm / Spare measuring bar, cross section 12x12mm	2140 101
Ersatz-Messlupe 10x / Spare measuring magnifier 10x	2166 101

## Rückprallhärteprüfer SKLEROGRAF

## Rebound hardness testers SKLEROGRAF



- ▶ Härte HB / HV / HRC wird durch den Rückprallwert (Skala am Gerät) mit Hilfe der Umrechnungstabelle bestimmt
- ▶ Werkstückmasse min. 1kg
- ▶ Lieferung im Etui inkl. Vergleichstabelle

- ▶ Hardness HB / HV / HRC is determined by the rebound travel (measured on the scale on the device) with the aid of a conversion table
- ▶ Workpiece weight min. 1kg
- ▶ Delivered in a case incl. comparison table



No. 2142 101

! Ausführung mit Einschraubgewinde sowie Prisenfuß oder Prüfamboss auf Anfrage.

! Versions with screw thread, V base or test anvil on request .

kg	Nº
0,3	2142 101

## Digital-Stoppuhren

## Digital stop watches



- ▶ wasserdicht
- ▶ LCD-Display 2,5-zeilig
- ▶ ABS Gehäuse
- ▶ Lieferung mit Schutztasche und Kordel

- ▶ Waterproof
- ▶ 2.5-line LCD display
- ▶ ABS housing
- ▶ Delivered with protective bag and cord

### Funktionen:

- ▶ Start / Stop / Reset
- ▶ Addition / Split / Lap / short Lap
- ▶ Uhrzeit / Datum
- ▶ Split / Lap und Uhrzeit während der Messung abrufbar
- ▶ Speicher 65x pro Zeitart
- ▶ Pacer (akustischer Taktgeber)
- ▶ Count-Down mit Signal

### Funktionen:

- ▶ Start / Stop / Reset
- ▶ Addition / Split / Lap / Short lap
- ▶ Time / Date
- ▶ Split / Lap and time recallable during measuring
- ▶ Memory 65x per time type
- ▶ Pacer (audible timer)
- ▶ Countdown with signal

Zeit / Time max.	≤ε	mm	kg	Nº
10 Std. / hours	1/100 Sec.	90x60x19	0,085	2137 202



No. 2137 202

## Digital-Stoppuhren STRATOS

## Digital stop watches STRATOS



- ▶ staub- und wassergeschützt
- ▶ LCD-Display
- ▶ ABS Gehäuse
- ▶ Lieferung einzeln verpackt mit Kordel

- ▶ Dust and water proof
- ▶ LCD display
- ▶ ABS housing
- ▶ Delivered in individual packages with cord

### Funktionen:

- ▶ Start / Stop / Reset
- ▶ Addition / Split / Dual

### Funktionen:

- ▶ Start / Stop / Reset
- ▶ Addition / Split / Dual



Zeit / Time max.	≤ε	mm	kg	Nº
10 Std. / hours	1/100 Sec.	66x70x21	0,06	2138 202



No. 2138 202

**Digital-Rauheitsmessgerät POCKET**

**Digital surface roughness testers POCKET**

  **TOP**

- ▶ Anzeige Ra und Rz
- ▶ LCD Display
- ▶ integrierter Microfaster
- ▶ Tastspitze Diamant R 5
- ▶ Taststrecke 6mm
- ▶ Filter RC
- ▶ Schutzschieber für Tastspitze
- ▶ Auto-Off
- ▶ mm/inch Umschaltung
- ▶ Lieferung im Etui, inkl. Rauheitsnormal, Werkskalibrierschein, Akku und Ladegerät

- ▶ Ra and Rz indication
- ▶ LCD display
- ▶ Integrated micro probe
- ▶ Diamond probe tip R 5
- ▶ Traverse length 6mm
- ▶ RC filter
- ▶ Protection for probe tip
- ▶ Auto-Off
- ▶ mm/inch commutation
- ▶ Delivered in a case, incl. roughness standard, works calibration certificate, storage battery and battery charger

**!** Rauheitsnormale auch mit DKD Kalibrierung auf Anfrage.

**!** Roughness standards, also with DKD calibration, on request.

**!** Gemäß DIN EN ISO 4288 wird die Grenzwellenlänge 2,5mm nur für Oberflächen empfohlen, deren Ra-Wert 10 µm nicht übersteigt.

**!** According to DIN EN ISO 4288, the cut-off length of 2.5 mm is only recommended for surfaces whose Ra value does not exceed 10 µm.

µm Ra µ / Rz µ	Cut Off mm	ℓ mm	Ⓜ kg	Nº
0,05-15 / 0,1-50	0,25 / 0,8 / 2,5	102x70x22	0,18	1574 202





No. 1574 202

Schutz für Tastspitze  
Protection for probe type

**Oberflächenvergleichsnorm**

**Surface roughness comparison standards**

  **TOP**

- ▶ zum Beurteilen der Oberflächengüte von Werkstücken
- ▶ Sicht- und Tastvergleich ( mit Fingernagel )
- ▶ 30 Normale ca. 22x10mm rostfrei, verschleißfest
- ▶ Lieferung in Kunststoffmappe

- ▶ For evaluation of surface quality of workpieces
- ▶ Visual and tactile comparison (with fingernail)
- ▶ 30 comparison standards approx. 22x10mm, rust-free and wear-resistant
- ▶ Delivered in plastic wrapper



No. 1576 101

**!** Rauheitsnormale für andere Bearbeitungsverfahren sowie Normale für Rauheitsmessgeräte auf Anfrage.

**!** Comparison standards for other machining processes or standards for surface roughness testers on request.

Anzahl Pieces	Bearbeitung Machining	Ra / µ	Rt / µ	Ⓜ kg	Nº
3	Flachläppen / Flat lapping	0,05 – 0,2	0,55 – 1,6	0,15	1576 101
3	Reiben / Reaming	0,4 – 1,6	3,0 – 10,0		
6	Flachschleifen / Surface grinding	0,05 – 1,6	0,55 – 10		
6	Stirnfräsen / End milling	0,4 – 12,5	3,0 – 50		
6	Umfangfräsen / Horizontal milling	0,4 – 12,5	3,0 – 50		
6	Längsdrehen / Cylindrical turning	0,4 – 12,5	3,0 – 50		

**Digitale Shore Härteprüfgeräte**

**Digital shore hardness testers**

  **IP65**

- ▶ zum Bestimmen der Shore Härte an Gummi und weichen Kunststoffen
- ▶ nach DIN 53505, ISO 868, ASTM D2240
- ▶ Schutzart IP 65
- ▶ großes LCD-Display
- ▶ Datenausgang RS 232
- ▶ Lieferung im Etui, inkl. Härtevergleichsplatten und UKAS Kalibrierschein

- ▶ For determining the Shore hardness in rubber and soft plastics
- ▶ Based on DIN 53505, ISO 868, ASTM D2240
- ▶ Protection class IP 65
- ▶ Large LCD display
- ▶ Data output RS 232
- ▶ Delivered in a box, incl. reference block and UKAS calibration certificate

- Funktionen:**
- ▶ Auto On/Off
  - ▶ ± Preset Funktion
  - ▶ Hold Funktion
  - ▶ Referenz Funktion (REF 1)

- Functions:**
- ▶ Auto On/Off
  - ▶ ± Preset function
  - ▶ Hold function
  - ▶ Reference function (REF 1)

Typ / Type	µm	ℓ	Ⓜ kg	Nº
Shore A	0-100	0,1	0,3	2146 801
Shore D	0-100	0,1	0,3	2146 802



## Shore Härteprüfgeräte mit konstanter Messkraft

## Shore hardness testers with constant measuring force



- ▶ zum Bestimmen der Shore Härte an Gummi und weichen Kunststoffen
- ▶ nach DIN 53505, ISO 7619, ISO 868, ASTM D2240
- ▶ exakte Messergebnisse durch gleichbleibende Prüfkraft
- ▶ mit Schleppeizer
- ▶ Lieferung im Etui

- ▶ For determining the Shore hardness in rubber and soft plastics
- ▶ Based on DIN 53505, ISO 7619, ISO 868, ASTM D2240
- ▶ Exact measurements through constant test force
- ▶ With max. indicator
- ▶ Delivered in a case

**I** Geräte mit Digitalablesung auf Anfrage.

**I** Testers with digital reading on request.

Typ / Type	범위	속도	중량 kg	№
Shore A	1-100	1	0,5	2146 501
Shore D	1-100	1	0,5	2146 502



No. 2146 501

## Shore Härteprüfgeräte

## Shore hardness testers



- ▶ zum Bestimmen der Shore Härte an Gummi und weichen Kunststoffen
- ▶ nach DIN 53505, ISO 7619, ISO 868, ASTM D2240
- ▶ mit Schleppeizer
- ▶ Lieferung in Kunstledertasche

- ▶ For determining the Shore hardness in rubber and soft plastics
- ▶ Based on DIN 53505, ISO 7619, ISO 868, ASTM D2240
- ▶ With max. indicator
- ▶ Delivered in imitation leather bag

Typ / Type	범위	속도	중량 kg	№
Shore A	1-100	1	0,25	2146 201
Shore D	1-100	1	0,25	2146 202



No. 2146 201

## Shore Härteprüfgeräte mit Ständer

## Shore hardness testers with stand



- ▶ zum Bestimmen der Shore Härte an Gummi und weichen Kunststoffen
- ▶ nach DIN 53505, ISO 7619, ISO 868, ASTM D2240
- ▶ mit Schleppeizer
- ▶ Lieferung inkl. Shore-Härteprüfgerät, einzeln verpackt

- ▶ For determining the Shore hardness in rubber and soft plastics
- ▶ Based on DIN 53505, ISO 7619, ISO 868, ASTM D2240
- ▶ With max. indicator
- ▶ Delivered incl. Shore hardness tester, in individual packages

Typ / Type	범위	속도	중량 kg	№
Shore A	1-100	1	5,5	2148 101
Shore D	1-100	1	9,5	2148 102



No. 2148 101

**Digital-Wanddickenmessgeräte für verschiedene Materialien**

**Digital wall thickness gauges for various materials**



- ▶ Schutzart IP 54
- ▶ LCD Display
- ▶ Umschaltung mm / inch
- ▶ Prüfkopf mit 1m Kabel
- ▶ Genauigkeit: ± 0.5 % des Messwertes
- ▶ Ultraschall-Impuls-Echo-Verfahren
- ▶ Schallgeschwindigkeit: 500 bis 9000 m/s
- ▶ Frequenzbereich 5 MHz, Prüfkopf ø 10 mm
- ▶ Oberflächentemperatur: -15°C...+ 60°C
- ▶ Gehäuse staub- und tropfwassergeschützt
- ▶ Datenausgang RS 232
- ▶ Lieferung im Koffer inkl. Sonde, Nullstandard und Batterien

- ▶ Protection class IP 54
- ▶ LCD display
- ▶ Commutation mm / inch
- ▶ Test head with 1m cable
- ▶ Accuracy: ± 0.5 % of the measured value
- ▶ Ultrasonic pulse echo technique
- ▶ Range of sound velocity 500 to 9000 m/s
- ▶ Frequency range 5 MHz, test head ø 10 mm
- ▶ Surface temperature: -15°C...+ 60°C
- ▶ Dust and water proof housing
- ▶ Data output RS 232
- ▶ Delivered in a box incl. probe, zero standard and batteries

**Anwendung:**

- ▶ Wird u.a. in der Materialdickenmessung eingesetzt, sowie in der Prüfung auf Korrosion von Druckbehältern, chemischen Apparaten, Kesseln, Öltanks, Rohrleitungen etc.

**Application:**

- ▶ Used for measuring thickness corrosion of pressure vessels, chemical equipment, boiler, oil storage tanks, pipes etc.

**Materialien:**

- ▶ Jedes harte Material, z.B. Stahl, Gusseisen, Aluminium, Kupfer, Messing, Zink, Glas (Quarz), Polyethylen, PVC, homogene Kunststoffe etc.

**Materials:**

- ▶ Any hard material, like steel, cast iron, aluminium, red copper, brass, zinc, quartz glass, polyethylene, PVC, homogeneous plastics etc.



No. 2149 905



No. 2149 905

mm	mm	mm	kg	Nº
1,2 ... 225	0,1	120 x 62 x 30	0,16	<b>2149 905</b>
Datenkabel, PC Software / Data cable, PC software				<b>2149 911</b>
Prüfkopf ø 6mm für dünne Materialien, Messbereich Stahl 1 – 50mm Test head ø 6mm for thin materials, measuring range steel 1 – 50mm				<b>2149 912</b>
Prüfkopf ø 12mm für heiße Materialien, Messbereich Stahl 1 – 225mm bei normalen Temperaturen und 4 – 100mm bei hohen Temperaturen bis zu 300°C Test head ø 12mm for hot materials, measuring range steel 1 – 225mm at normal temperature and 4 – 100mm at high temperature up to 300°C				<b>2149 913</b>

**Digital-Schichtdickenmessgerät EASY**

**Digital coating thickness gauges EASY**



- ▶ Schutzart IP 54
- ▶ LCD Display
- ▶ Integrierte Sonde
- ▶ Genauigkeit:
  - ± 3 % vom Messwert (Standard Modus)
  - ± 1 % vom Messwert (Offset-Accur Modus)
- ▶ Automatisches Erkennen des Grundwerkstoffes
- ▶ F = Stahl/Eisen / N = Nichteisen-Metalle
- ▶ Kleinste Messfläche ø 6mm
- ▶ Mindeststärke des Grundmaterials 0,3mm
- ▶ Datenausgang RS 232
- ▶ Lieferung im Koffer inkl. Sonde, Nullstandard, Distanzfolien und Batterien

- ▶ Protection class IP 54
- ▶ LCD display
- ▶ Integrated probe
- ▶ Accuracy:
  - ± 3 % of measured value (standard Mode)
  - ± 1 % of measured value (Offset-Accur mode)
- ▶ Automatic identification of the base material
- ▶ F = Steel/Iron / N = non-ferrous metal
- ▶ Smallest measuring surface ø 6mm
- ▶ Minimum thickness of base material 0.3mm
- ▶ Data output RS 232
- ▶ Delivered in a box incl. probe, zero standard, calibration foil and batteries

**I** Offset-Accur (Vergleichsmessung), das Gerät wird mit Nullstandard und Distanzfolie auf die exakte Schichtdicke voreingestellt.

**I** Offset accur (comparative measurement), the instrument will be presetted with zero standard and calibration foil on the exact coat thickness.

µm	µm	Material	mm	kg	Nº
0 ... 1250	0,1	F	131 x 65 x 28	0,08	<b>2149 111</b>
0 ... 1250	0,1	N	131 x 65 x 28	0,08	<b>2149 112</b>
0 ... 1250	0,1	FN	131 x 65 x 28	0,08	<b>2149 113</b>
Datenkabel, PC Software / Data cable, PC software					<b>2149 119</b>



No. 2149 113



No. 2149 113

## Digital-Schichtdickenmessgerät mit erweitertem Display

## Digital coating thickness gauges with enlarged display



TOP

- ▶ Schutzart IP 54
- ▶ LCD Display
- ▶ Externe Sonde mit 1m Kabel
- ▶ Genauigkeit:
  - ± 3 % vom Messwert (Standard Modus)
  - ± 1 % vom Messwert (Offset-Accur Modus)
- ▶ Automatisches Erkennen des Grundwerkstoffes
- ▶ Nur ein Messkopf für F und N
- ▶ Interner Datenspeicher für 99 Messwerte
- ▶ Statistik – Funktion für Messwert, Durchschnittswert, Min., Max. sowie Anzahl der Werte
- ▶ Mindeststärke des Grundmaterials 0,3mm
- ▶ Datenausgang RS 232
- ▶ Lieferung im Koffer inkl. Sonde, Nullstandard, Distanzfolien und Batterien

- ▶ Protection class IP 54
- ▶ LCD display
- ▶ External probe with 1m cable
- ▶ Accuracy:
  - ± 3 % of measured value (standard Mode)
  - ± 1 % of measured value (Offset-Accur mode)
- ▶ Automatic identification of the base material
- ▶ Only 1 probe for F and N
- ▶ Internal memory for 99 measuring results
- ▶ Statistic – Function for measured value, average value, min. and max value and number of values
- ▶ Minimum thickness of base material 0.3mm
- ▶ Data output RS 232
- ▶ Delivered in a box incl. probe, zero standard, calibration foil and batteries



No. 2149 115

Großes erweitertes Display für Messwert und Statistikdaten.  
Enlarged display for measuring value and statistic data.

! Offset-Accur (Vergleichsmessung), das Gerät wird mit Nullstandard und Distanzfolie auf die exakte Schichtdicke voreingestellt.

! Offset accur (comparative measurement), the instrument will be preselected with zero standard and calibration foil on the exact coat thickness.

µm	µm	Material	Kleinste Messfläche Smallest measuring surface Ø mm	L mm	m kg	Nº
0 ... 1250	0,1	F + N	3	126 x 65 x 35	0,08	2149 114
0 ... 1250	0,1	F + N	6	126 x 65 x 35	0,08	2149 115
0 ... 5000	0,1	F + N	6	126 x 65 x 35	0,08	2149 116
Datenkabel, PC Software / Data cable, PC software						2149 119

### Schichtdickenmessung, Messverfahren

#### Beispiel 1:

Messung unmagnetischer Schichten auf Eisen, Stahl, etc.

Aluminium, Chrom, Kupfer, Gummi, Farbe

Stahl, Eisen, Legierungen, magnetischer (Edel-) Stahl

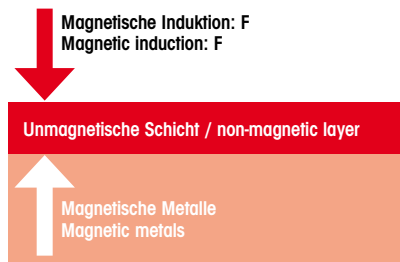

### Coating thickness measurements

#### Example 1:

Measurement of non-magnetic coatings on steel and other metals

Aluminium, Chrome, Copper, Rubber, Paint

Steel, Iron, Alloy, Magnetic Steel, Magnetic stainless steel

#### Beispiel 2:

Messung unmagnetischer Schichten (bsp. Lack, Eloxan, etc.) auf unmagnetischen Metallen.

Lack, Farbe, Emaille, Chrom, Kupfer, Zink, Kunststoff und elektrische Isolierungsschichten

Kupfer, Aluminium, Zink, Bronze, Messing, Zinn, Blech

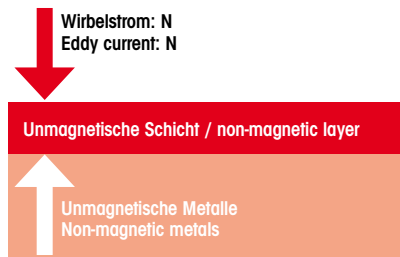

#### Example 2:

Measurement of insulation coatings on non-ferrous metals

Varnish, paint, enamel, chrome, copper, zircon, plastic and electrical isolation coatings

Copper, aluminium, zinc, bronze, brass, tin

#### Beispiel 3:

Universelle Verwendung für beide Messtypen (F und N) möglich.

Alle Schichten wie bei F und N

Alle Metalle wie bei F und N

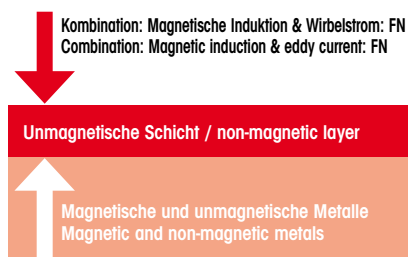

#### Example 3:

Universal use for both methods F and N.

Any layers as at F and N

Any metals as at F and N

# 15

## Waagen

Balances

## Kraftmessgeräte

Force measuring instruments

## Lupen

Magnifiers

## Lupenleuchten

Illuminated magnifiers



**TOP**

Klapplupen „Tech-Line“  
Folding magnifiers „Tech-Line“



15.11

Standlupen „Tech-Line“  
Stand magnifiers „Tech-Line“



15.13

Taschenmikroskope „Tech-Line“  
Pocket microscopes „Tech-Line“



15.14

Ring-Lupenleuchte LED  
Circular illuminated magnifiers LED



15.17

15



+49 (0) 60 21 42 999 00

## Digital-Präzisionswaagen

## Digital precision balances



- ▶ Schutzart IP54
- ▶ großes LCD Display
- ▶ Wägeplatte aus Edelstahl, Gehäuse aus Kunststoff
- ▶ Abmessung 165x230x80mm
- ▶ Steckernetzteil 230V, optional Batterie oder Akkubetrieb
- ▶ Lieferung einzeln verpackt inkl. Prüfgewicht und Netzteil

### Funktionen:

- ▶ Trieren
- ▶ Justierprogramm
- ▶ Stückzählen mit Referenz 5, 10, 25 und 50 Stück
- ▶ Wägeeinheit wählbar g, dwt, mom, tol
- ▶ Rezeptur mit Speicher der Bestandteile
- ▶ Prozentbestimmung ( Abweichung vom Referenzgewicht in % )
- ▶ Datenschnittstelle RS 232

- ▶ Protection class IP54
- ▶ Large LCD display
- ▶ Stainless steel weighing plate, plastic housing
- ▶ Dimension 165x230x80mm
- ▶ AC adaptor 230 V, optional battery or storage battery
- ▶ Delivered in individual packages incl. test weight and mains adaptor

### Functions:

- ▶ Taring
- ▶ Adjusting program
- ▶ Counting of pieces with reference as per 5, 10, 25 and 50 pieces
- ▶ Selectable weighing units g, dwt, mom and tol
- ▶ Net total weighing with memory of components
- ▶ Percentage determination (deviation from reference weight in %)
- ▶ Data interface RS 232



**!** DKD Kalibrierung gegen Aufpreis.

**!** DKD calibration at extra charge.

g	$\leq$ g	Linearität / Linearity $\pm$ g	min.  g	mm	kg	Nº
200	0,01	0,003	0,002	Ø81	1,1	2210 102
1000	0,01	0,003	0,2	130x130	1,4	2210 105
3500	0,01	0,05	0,02	130x130	1,4	2210 107
6000	0,1	0,3	0,2	170x150	2,0	2210 110
Datendrucker / Data printer						2215 101
Akku extern, Betriebsdauer ca.230h / External storage battery, operation period approx. 230hrs						2215 102



### Prüfgewichte für Waagen

Wir liefern alle Arten von Prüfgewichten für Präzisionswaagen im Bereich von 1mg bis 50kg, als Einzelgewichte oder Gewichtssätze im Etui. Je nach Anwendungsbereich sind Prüfgewichte aus rostfreiem Stahl, Messing blank oder vernickelt in unterschiedlichen Genauigkeitsklassen, lieferbar. Eine DKD-Kalibrierung durch ein akkreditiertes Labor ist ebenfalls möglich.

Zur Angebotsabgabe bitten wir um Ihre Anfrage mit Angabe des Materials und Gewichts sowie der gewünschten Toleranz in  $\pm$ mg.

### Test weights for balances

We supply all types of test weights for precision balances in the range of 1 mg up to 50 kg as individual weights or weight sets in box. According to application area, test weights can be supplied in stainless steel and in shiny or nickel-plated brass in different accuracy classes. A DKD calibration certificate from an accredited laboratory is likewise possible.

For the preparation of a quotation, we request you to add specification of the material and weight as well as the required tolerance in  $\pm$ mg in your enquiry.





## Digital-Plattformwaagen

## Digital platform balances



- ▶ Schutzart IP54
- ▶ großes LCD Display
- ▶ Wägeplatte aus Edelstahl
- ▶ Anzeige mit Wandhalterung, Gehäuse aus Kunststoff 200x100x55mm
- ▶ Steckernetzteil 230V, optional Batterie oder Akkubetrieb
- ▶ Lieferung einzeln verpackt inkl. Netzteil

### Funktionen:

- ▶ Trieren
- ▶ Justierprogramm
- ▶ Stückzählen mit Referenz 5, 10, 25 und 50 Stück
- ▶ Wägeeinheit wählbar g, lb, oz, ozt, tLT, tLH
- ▶ Rezeptur mit Speicher der Bestandteile
- ▶ Prozentbestimmung ( Abweichung vom Referenzgewicht in % )
- ▶ Datenschnittstelle RS 232

- ▶ Protection class IP54
- ▶ Large LCD display
- ▶ Stainless steel weighing plate
- ▶ Display with wall holder, plastic housing 200x100x55mm
- ▶ AC adaptor 230V, optional battery or storage battery
- ▶ Delivered in individual packages incl. mains adaptor

### Functions:

- ▶ Taring
- ▶ Adjusting program
- ▶ Counting of pieces with reference as per 5, 10, 25 and 50 pieces
- ▶ Selectable weighing units g, lb, oz, ozt, tLT and tLH
- ▶ Net total weighing with memory of components
- ▶ Percentage determination (deviation from reference weight in %)
- ▶ Data interface RS 232

**!** DKD Kalibrierung gegen Aufpreis, Modelle mit Feinanzeige auf Anfrage.

**!** DKD calibration at extra charge, versions with high resolution display on request.

kg	g	min. g	mm	kg	Nº
3 / 6	1 / 2	4	318 x 308	4,0	2213 102
6 / 15	2 / 5	10	318 x 308	4,0	2213 103
15 / 35	5 / 10	10	318 x 308	4,0	2213 104
30 / 60	10 / 20	20	318 x 308	4,0	2213 106
60 / 150	20 / 50	40	318 x 308	4,0	2213 108
Datendrucker / Data printer					2215 101
Akku intern, Betriebsdauer ca. 15h / Internal storage battery, operation period approx. 15hrs					2215 102
Stativ zum Hochsetzen der Anzeige / Stand for display mounting					2215 103



Anzeige mit Wandhalterung, abnehmbar.  
Display with wall holder, removable.



Stativ zum Hochsetzen der Anzeige.  
Stand for display mounting.



## Digital-Handhängewaagen

## Digital hand held hanging balances



- ▶ Schutzart IP54
- ▶ großes LCD Display
- ▶ ausziehbares Maßband 100cm
- ▶ Kunststoffgehäuse 90x30x175mm
- ▶ Länge mit Haken 270mm
- ▶ Lieferung einzeln verpackt inkl. Haken und Batterie

### Funktionen:

- ▶ Trieren
- ▶ Justierprogramm
- ▶ Hold Funktion

- ▶ Protection class IP54
- ▶ Large LCD display
- ▶ Extendable measuring tape 100cm
- ▶ Plastic housing 90x30x175mm
- ▶ Length with hook 270mm
- ▶ Delivered in individual packages incl. hook and battery

### Functions:

- ▶ Taring
- ▶ Adjusting program
- ▶ Hold function

kg	g	kg	Nº
15	20	0,25	2155 101
50	50	0,25	2155 102
50	100	0,25	2155 103



No. 2155 101

## Digital-Hängewaagen

## Digital hanging balances



- ▶ Schutzart IP54
- ▶ großes LCD Display
- ▶ Kunststoffgehäuse 80x45x150mm
- ▶ Länge mit Haken 290mm
- ▶ Lieferung einzeln verpackt inkl. Haken, Karabiner und Batterie

### Funktionen:

- ▶ Trieren
- ▶ Justierprogramm
- ▶ Hold Funktion

- ▶ Protection class IP54
- ▶ Large LCD display
- ▶ Plastic housing 80x45x150mm
- ▶ Length with hook 290mm
- ▶ Delivered in individual packages incl. hook, carabiner and battery

### Functions:

- ▶ Taring
- ▶ Adjusting program
- ▶ Hold function

2155 2.. :

Standardablesung

2155 2.. :

Standard reading

2155 3.. :

Feinablesung

2155 3.. :

High resolution reading

! DKD Kalibrierung gegen Aufpreis.

! DKD calibration at extra charge.

kg	kg	g	Nº	g	Nº
20	0,4	50	2155 201	10	2155 301
50	0,4	100	2155 202	20	2155 302
100	0,4	200	2155 203	50	2155 303
200	0,4	500	2155 204	100	2155 304



No. 2155 204

## Digital-Kranwaagen mit beidseitigem Display

## Digital crane scales with doubleside display



- ▶ großes Display, selbstleuchtend
- ▶ Genauigkeit 0,2% vom Max
- ▶ robustes Metallgehäuse
- ▶ Arbeitstemperatur 0...+40°C
- ▶ Fernbedienung drahtlose Reichweite ca. 20m
- ▶ Lieferung einzeln verpackt inkl. Fernbedienung, Akku mit Ladegerät, Lasthaken und Schäkel

### Funktionen:

- ▶ Trieren
- ▶ Justierprogramm
- ▶ Anzeige Brutto / Tara / Netto
- ▶ Wägeeinheiten wählbar kg, lb
- ▶ Auto OFF nach ca. 5min.
- ▶ Hold Funktion
- ▶ Ladeanzeige für Akku

- ▶ Large display, self illuminated
- ▶ Accuracy 0.2% of Max
- ▶ Sturdy metal housing
- ▶ Working temperature 0...+40°C
- ▶ Wireless remote control range approx. 20m
- ▶ Delivered in individual packages incl. remote control, storage battery, hook and shackle

### Functions:

- ▶ Taring
- ▶ Adjusting program
- ▶ Display of Gross / Tare / Net
- ▶ Selectable weighing units kg and lb
- ▶ Auto OFF after approx. 5min.
- ▶ Hold function
- ▶ Loading display for storage battery

! DKD Kalibrierung gegen Aufpreis.

! DKD calibration at extra charge.

kg	kg	A mm	B mm	C mm	D mm	kg	Nº
150	0,05	26	25	358	390	13,0	2156 901
300	0,1	26	25	358	390	13,0	2156 902
600	0,2	26	25	358	390	13,0	2156 903



No. 2156 901



Rückseite  
Back side

## Digital-Kranwaagen

## Digital crane scales



- ▶ großes Display, selbstleuchtend
- ▶ Genauigkeit 0,2% vom Max
- ▶ robustes Metallgehäuse
- ▶ Arbeitstemperatur 0...+40°C
- ▶ Fernbedienung drahtlose Reichweite ca. 20m
- ▶ Lieferung einzeln verpackt inkl. Fernbedienung, Akku mit Ladegerät, Lasthaken und Schäkkel

### Funktionen:

- ▶ Trieren
- ▶ Justierprogramm
- ▶ Anzeige Brutto / Tara / Netto
- ▶ Auto OFF nach ca. 5min.
- ▶ Hold Funktion
- ▶ Ladeanzeige für Akku

- ▶ Large display, self illuminated
- ▶ Accuracy 0.2% of Max
- ▶ Sturdy metal housing
- ▶ Working temperature 0...+40°C
- ▶ Wireless remote control range approx. 20m
- ▶ Delivered in individual packages incl. remote control, storage battery, hook and shackle

### Functions:

- ▶ Taring
- ▶ Adjusting program
- ▶ Display of Gross / Tare / Net
- ▶ Auto OFF after approx. 5min.
- ▶ Hold function
- ▶ Loading display for storage battery

! DKD Kalibrierung gegen Aufpreis.

! DKD calibration at extra charge.

kg	≤ kg	A mm	B mm	C mm	D mm	kg	Nº
1000	0,1	80	40	540	610	15,0	2156 904
3000	0,5	75	40	540	610	16,5	2156 905
5000	0,5	75	50	650	770	25,0	2156 906
10000	1,0	100	60	750	1060	37,0	2156 907



No. 2156 904

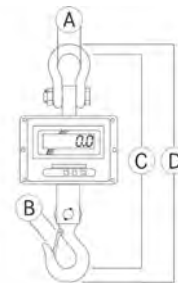

## Kraftmessdosen für Druckkraftmessung

## Load cells for pressure load measurement



- ▶ hydraulisches Messsystem, wartungsfrei
- ▶ Anzeigeeinheit mit Maximumzeiger
- ▶ Gehäuse und Kolben aus Edelstahl
- ▶ 3 Gewindebohrungen M5 am Gehäuseboden
- ▶ Genauigkeit ±1,6% v. EW
- ▶ Lieferung einzeln verpackt

- ▶ Maintenance-free hydraulic measuring system
- ▶ Display unit with maximum indicator
- ▶ Stainless steel housing and piston
- ▶ 3 threaded holes M5 on the bottom of the housing
- ▶ Accuracy ±1.6% fs
- ▶ Delivered in individual packages

! Andere Bauformen auf Anfrage.

! Other versions on request.

↓ kN	≤ kN	Kolben / Piston cm <sup>2</sup>	∅ mm	mm	kg	Nº
0,25	0,01	10	75	30	1,2	2250 101
0,6	0,02	10	75	30	1,2	2250 102
1	0,05	10	75	30	1,2	2250 103
1,6	0,05	10	75	30	1,2	2250 104
2,5	0,1	10	75	30	1,2	2250 105
4	0,1	10	75	30	1,2	2250 106
6	0,2	10	75	30	1,2	2250 107
10	0,5	10	75	30	1,2	2250 108
16	0,5	10	75	30	1,2	2250 109
25	1	10	75	30	1,2	2250 110
32	2	10	75	30	1,2	2250 111
40	2	10	75	30	1,2	2250 112
60	2	10	75	30	1,2	2250 113
80	2	80	138	41	4,6	2250 114
200	10	80	138	41	4,6	2250 115
250	10	80	138	41	4,6	2250 116
Koffer / Box						2210 901



No. 2250 103



1kN = 1000N (~100kg)  
1DaN = 10N (~1kg)

Andere Bauformen auf Anfrage.  
Other versions on request.

## Digital Kraftmessgeräte für Zug- und Druckkraft

## Digital force measuring gauges for traction force and pressure



- ▶ Für Handbetrieb oder zum Einbau in Prüfvorrichtungen
- ▶ großes, beleuchtetes LCD Display, um 180° drehbar
- ▶ Akkubetrieb
- ▶ Genauigkeit:  $\pm 0.5\%$  fs
- ▶ Überlastschutz 150%
- ▶ Wählbare Einheiten: Newton, kg, lb
- ▶ Lieferung im Koffer inkl. Akku, Ladegerät, Zubehörsatz (Flachkopf, Nutenkopf, Konus, Spatel, Haken, Verlängerungswelle)

### Funktionen:

- ▶ ON / OFF
- ▶ Grenzwert-Programmierung (min / max)
- ▶ Taring
- ▶ Umschaltung N/ kg / lb
- ▶ Spitzenwert-Speicher für Zug- und Druckkraft
- ▶ Datenausgang RS 232
- ▶ Überlastausgang

- ▶ For hand operation or for mounting on test control units
- ▶ Large lit up LCD display, turnable through 180°
- ▶ Battery operation
- ▶ Accuracy:  $\pm 0.5\%$  fs
- ▶ Overload protection 150%
- ▶ Selectable measurement units: N, kg, lb
- ▶ Delivered in box incl. storage battery, charger and accessories (Pan head, groove head, cone, spatula, hook and extension shaft)

### Funktionen:

- ▶ ON / OFF
- ▶ Programmable high / low setpoints
- ▶ Taring
- ▶ Commutation N/ kg / lb
- ▶ Peak value memory for traction force and pressure
- ▶ Data output RS 232
- ▶ Overload output

### 2150 401 – 2150 406 :

Digital Kraftmessgeräte mit integrierter Wägezelle

### 2150 401 – 2150 406 :

Digital force measuring gauges with integrated load cell

### 2150 407 – 2150 410 :

Digital Kraftmessgeräte mit externer Wägezelle

### 2150 407 – 2150 410 :

Digital force measuring gauges with external load cell



量程 N	分辨率 N	高度 mm	重量 kg	型号 No
2	0,001	238 x 63 x 36	0,7	2150 401
5	0,001	238 x 63 x 36	0,7	2150 402
10	0,005	238 x 63 x 36	0,7	2150 402x
20	0,01	238 x 63 x 36	0,7	2150 403
50	0,01	238 x 63 x 36	0,7	2150 404
100	0,05	238 x 63 x 36	0,7	2150 404x
200	0,1	238 x 63 x 36	0,7	2150 405
500	0,1	238 x 63 x 36	0,7	2150 406
1000	0,5	238 x 63 x 36	0,7	2150 407
2000	1,0	238 x 63 x 36	0,7	2150 408
5000	1,0	238 x 63 x 36	0,7	2150 409
10000	5,0	238 x 63 x 36	0,7	2150 410
> 10000 auf Anfrage / on request				
Datenkabel, PC Software / Data cable, PC software				2150 911

## Prüfstand für digitale Kraftmessgeräte

## Test stand for digital force measuring gauges



- ▶ Kurbelprüfstand mit Handrad, mit digitaler Längenmessung
- ▶ Ablesung 0,01mm
- ▶ Vertikale und horizontale Anwendungen
- ▶ Spindelhöhe 297mm ab Bodenplatte
- ▶ Hub einer Drehung 3,1mm
- ▶ Geeignet für ULTRA Nr. 2150 4.. und Nr. 2150 6.. bis 500N
- ▶ Lieferung ohne Kraftmessgerät

- ▶ Manuel test stand with hand wheel, with digital length measuring
- ▶ Reading 0.01mm
- ▶ Vertical and horizontal use
- ▶ Max travel 297 mm from base plate
- ▶ Travel distance per knob rotation 3.1mm
- ▶ Usable for ULTRA No. 2150 4.. and No. 2150 6.. up to 500N
- ▶ Delivered without force measuring gauge

重量 N	高度 mm	重量 kg	型号 No
500	495 x 235 x 150	8,3	2150 955



**Digital-Kraftmessgeräte STANDARD**  
für Zug- und Druckkraft

**Digital force measuring gauges STANDARD**  
for traction force and pressure



- ▶ Für Handbetrieb oder zum Einbau in Prüfvorrichtungen
- ▶ großes LCD Display, um 180° drehbar
- ▶ Akkubetrieb
- ▶ Genauigkeit:  $\pm 0.5\%$  fs
- ▶ Überlastschutz: 200% des Messbereichs
- ▶ Wählbare Einheiten: Newton, kg, lb, oz
- ▶ Lieferung einzeln verpackt inkl. Batterie/Netzteil, Zubehörsatz (Flachkopf, Nutenkopf, Konus, Spatel, Haken, Verlängerungswelle)

- ▶ For hand operation or for mounting on test control units
- ▶ Large LCD display, turnable through 180°
- ▶ Battery operation
- ▶ Accuracy:  $\pm 0.5\%$  fs
- ▶ Overload protection: 200 % of capacity
- ▶ Selectable measurement units: N, kg, lb, oz
- ▶ Delivered individual packages incl. mains adapter battery, charger and accessories (Pan head, groove head, cone, spatula, hook and extension shaft)

**Funktionen:**

- ▶ ON / OFF
- ▶ Taring
- ▶ Umschaltung N/ kgf / lbf
- ▶ Spitzenwert-Speicher für Zug- und Druckkraft

**Functions:**

- ▶ ON / OFF
- ▶ Taring
- ▶ Commutation N/ kgf / lbf
- ▶ Peak value memory for traction force and pressure



力 N	Δε N	寸 mm	重 kg	№
10	0,005	195 x 84 x 35	0,6	2150 600
25	0,01	195 x 84 x 35	0,6	2150 601
50	0,02	195 x 84 x 35	0,6	2150 602
100	0,05	195 x 84 x 35	0,6	2150 602x
250	0,1	195 x 84 x 35	0,6	2150 603
500	0,2	195 x 84 x 35	0,6	2150 604
1000	0,5	195 x 84 x 35	0,6	2150 605

**Federwaagen KONTAKTOR**  
für Zug- und Druckkraft

**KONTAKTOR dial tension gauges**  
for traction and pressure



- ▶ doppelte Skala zum Messen in beide Richtungen
- ▶ Genauigkeit  $\pm 0,01x$  (Messbereich + Messwert)
- ▶ Überlastungsschutz durch Anschlag
- ▶ ab Nr. 2150 104 / 2150 204 mit Schleppzeiger
- ▶ Lieferung in Styroporetui

- ▶ Double scales for measuring in both directions
- ▶ Accuracy  $\pm 0.01x$  (Measuring range + Measuring value)
- ▶ Overload protection with back
- ▶ from No. 2150 104 / 2150 204 with maximum pointer
- ▶ Delivered in styrofoam case



Taster / Probe mm	Ø-mm	重 kg	力 g	Δε g	№	力 cN	Δε cN	№
29	36	0,11	0,3 – 3	0,1	2150 101	-	-	-
29	36	0,11	0,6 – 6	0,2	2150 102	-	-	-
29	36	0,11	1,5 – 15	0,5	2150 103	1,5 – 15	0,5	2150 203
29	36	0,11	3,0 – 30	1	2150 104	3 – 30	1	2150 204
29	36	0,11	5,0 – 50	1	2150 105	5 – 50	1	2150 205
29	36	0,11	10 – 100	2	2150 106	10 – 100	2	2150 206
29	36	0,11	25 – 250	5	2150 107	25 – 250	5	2150 207

Taster / Probe mm	Ø-mm	重 kg	力 g	Δε g	№	力 N	Δε N	№
48	72	0,21	50 – 500	10	2150 108	0,5 – 5	0,1	2150 308
48	72	0,21	100 – 1000	20	2150 109	1 – 10	0,2	2150 309
48	72	0,21	200 – 2000	40	2150 110	2 – 20	0,4	2150 310
48	72	0,21	300 – 3000	50	2150 111	3 – 30	0,5	2150 311
48	72	0,21	400 – 4000	100	2150 112	4 – 40	1	2150 312
48	72	0,21	500 – 5000	100	2150 113	5 – 50	1	2150 313
8	72	0,21	1000 – 10000	200	2150 114	10 – 100	2	2150 314

## Federwaagen zylindrische Dynamometer

## Spring balance cylindrical dynamometer



TOP

- ▶ Außenrohr, Haken und Ring vernickelt
- ▶ Innenrohr versilbert, Skala schwarz ausgelegt
- ▶ Genauigkeit ±1% vom Messwert
- ▶ Überlastungsschutz ca. 20% vom Max
- ▶ Lieferung einzeln verpackt inkl. Haken und Ring

- ▶ Nickel-plated outer tube, hook and ring
- ▶ Silver-plated inner tube and black-finished scale
- ▶ Accuracy ±1% of measured value
- ▶ Overload protection approx. 20% of max.
- ▶ Delivered in individual packages incl. hook and ring

kg	g	kg	Nº	N	N	kg	Nº
0,1	1	0,15	2151 101	1	0,01	0,15	2151 201
0,2	2	0,15	2151 102	2	0,02	0,15	2151 202
0,5	5	0,15	2151 103	5	0,05	0,15	2151 203
1,0	10	0,15	2151 104	10	0,1	0,15	2151 204
2,5	25	0,15	2151 105	25	0,25	0,15	2151 205
5	50	0,15	2151 106	50	0,5	0,15	2151 206
10	200	0,15	2151 107	100	2	0,15	2151 207
20	200	0,20	2151 108	200	4	0,2	2151 208
30	500	0,35	2151 109	300	5	0,35	2151 209
60	1000	0,70	2151 110	600	10	0,7	2151 210
100	1000	0,95	2151 111	1000	10	0,95	2151 211



## Digital-Längenmaßstab CARBON mit Lupe

## Digital length rule CARBON with magnifier



TOP



Gehärtet  
Hardened



CARBON



No. 1854 6.

Stangenquerschnitt  
Bar cross section  
30x10mm

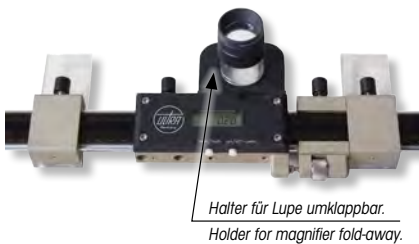

Halter für Lupe umklappbar.  
Holder for magnifier fold-away.

- ▶ Werksnorm
- ▶ Zum Messen von Abständen auf Flächen
- ▶ Schutzart IP 54
- ▶ Feststellschraube
- ▶ Stange aus Kohlefaser 30x10mm, Führungselemente aus verchromtem Stahl
- ▶ Extrem geringes Gewicht, hohe Formstabilität
- ▶ großes LCD Display
- ▶ Lieferung im Holzetui mit Lupe

### Funktionen:

- ▶ Ein/Aus, mm/inch Umschaltung, ± Preset Funktion, O-Punkt an jeder Position, Hold Funktion, Datenausgang Opto

### Handhabung:

- ▶ Anfangspunkt mit Lupe anvisieren und Anzeige nullen. Mit dem Schieber bis auf den Endpunkt fahren und genaue Position mit Lupe anvisieren. Exakte Länge auf der Digital-Anzeige ablesen.

- ▶ Works standard
- ▶ To measure a distance on a surface
- ▶ Protection class IP 54
- ▶ Locking screw
- ▶ Carbon fibre bar 30x10mm, guiding elements made of chromed steel
- ▶ Extremely low weight, high strength of shape
- ▶ Large LCD display
- ▶ Delivered in wooden box incl. magnifier

### Functions:

- ▶ On/Off, mm/inch commutation, ± preset function, Zero setting at any position, Hold function, Data output Opto

### Operation:

- ▶ Focus on the initial point with the magnifier and reset the display. Slide the calliper to the end point and focus on the exact position with the magnifier. Read the exact length on the digital display.

! Größere Messbereiche auf Anfrage.

! Larger measuring ranges on request.

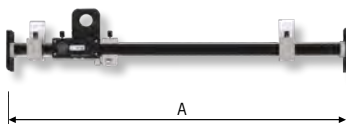

mm	inch	A mm	mm	inch	kg	Nº
450	18	720	0,01	.0005	1,0	1854 601
750	30	1020	0,01	.0005	1,9	1854 602
1150	45	1420	0,01	.0005	3,0	1854 603
1450	57	1720	0,01	.0005	3,7	1854 604

> 1450mm auf Anfrage / on request

Datenkabel RS232 (2m) / Data cable RS232 (2m)

1850 203

Datenkabel USB (2m) / Data cable USB (2m)

1850 204

## Linsen, Begriffserklärungen

Grundsätzlich wird zwischen sphärischen und asphärischen Linsen unterschieden.



**Sphärische Linsen** haben in Ihrer Krümmung einen einheitlichen Radius, dies führt zu leichten Verzerrungen der Abbildung im Randbereich.

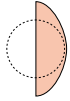

**Asphärische Linsen** haben unterschiedliche Krümmungen (keinen einheitlichen Radius) und deshalb eine deutlich bessere Abbildungsqualität im Randbereich.

Die Flächen einer Linse können konvex, eben (plan) oder konkav sein. In der Regel werden sphärische Linsen mit folgenden unterschiedlichen Linsengeometrien verwendet:



**Plankonvexe Form**  
Lichtsammelnde Wirkung, eine Fläche ist plan die andere ist nach außen gewölbt.

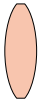

**Bikonvexe Form**  
Bessere Abbildungsqualität und höhere Vergrößerung als plankonvexe Linsen. Beide Flächen sind nach außen gewölbt.



**Aplanatische Form**  
Randscharfe und verzerrungsfreie Abbildung. Zwei plankonvexe Linsen sind mit den gewölbten Flächen zueinander angeordnet.

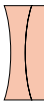

**Achromatische Form**  
Farbtechte Abbildungen. Unterdrückt störenden Farbsaum am Randbereich. Eine plankonvexe und eine bikonkave Linse sind hintereinander angeordnet.

### Dioptrienzahl, Vergrößerung

Die Dioptrienzahl (D) bezeichnet das Lichtbrechungsvermögen einer Linse. Der Vergrößerungsfaktor (V) errechnet sich nach folgender Formel:  $V = (D / 4) + 1$

## Internationale Maßeinheiten:

### Länge / Length

1 mm	0,03937 Zoll
1 cm	0,3937 Zoll
1 m	39,37 Zoll = 3,28083 Fuss = 1,0936 Yard
1 km	3280,83 Fuss = 1093,61 Yard = 0,62137 Meilen
1 Zoll	25,4 mm = 2,54 cm = 0,0254 m
1 Fuss	304,8 mm = 30,48 cm = 0,3048 m
1 Yard	0,9144 m
1 Meile	1,609 km

### Gewicht / Weight

1 g	0,035 Unzen = 15,432 Grans
1 kg	2,2046 Pounds = 35,274 Unzen(av)
1 to	2204,6 Pounds = 0,9842 Long Ton = 1,1023 Short Ton (av)
1 Gran	0,0648 g
1 Unze(av) oz.	28,35 g
1 Pound(av) lb.	0,4536 kg
1 Short Ton	0,907 to
1 Long Ton	1,016 to

## Lenses, definitions

Fundamentally, the spherical and aspherical lenses are distinguished.



**Spherical lenses** have a uniform radius in their curve, which lead to slight distortion of the image in the border area.

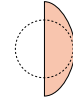

**Aspherical lenses** have differing curves (no uniform radius) and therefore have a clearly better image quality in the border area.

The surfaces of a lens can be convex, flat (plane) or concave. Generally, spherical lenses are used with the following differing lens geometries:

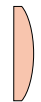

**Plano-convex shape**  
Light collecting effect, one surface is plane and the other is curved towards the outside.



**Biconvex shape**  
Better image quality and higher magnification than plano-convex lenses. Both surfaces are curved towards the outside.



**Aplanatic shape**  
Sharp edge and distortion-free image. Two plano-convex lenses are arranged together with the curved surfaces.

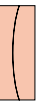

**Achromatic shape**  
Colour-fast images. Suppresses disturbing colour fringe in the border area. A plano-convex and a biconcave lens are arranged one after the other.

### Dioptre number, magnification

The dioptre number (D) specifies the refractory property of a lens. The magnification factor (V) is calculated according to the following formula:  $V = (D / 4) + 1$

## International measurements:

### Kraft / Force

1 N	0,101972 kp = 0,224809 lb.f
1 kp	9,80665 N = 2,204623 lb.f
1 lb.f	4,448222 N = 0,453592 kp

### Geschwindigkeit / Speed

1 km/h	0,62140 mph = 16,66670 m/min = 0,27780 m/sec
1 mph	1,60900 km/h = 26,82000 m/min = 0,44700 m/sec
1 ft/min	0,30480 m/min
1 m/min	3,28100 ft/min
1 ft/sec	0,30480 m/sec
1 m/sec	3,28100 ft/sec

### Temperatur / Temperature

0 °C	32 °F
37,7 °C	100 °F
100 °C	212 °F
0 °F	-17,778 °C
100 °F	37,778 °C

## Kopfbandlupen

## Headband magnifiers



- ▶ Silikatoptik binokular, auswechselbar
- ▶ Linsenträger hochklappbar
- ▶ Metallgehäuse weißlackiert
- ▶ Kopfband aus Bandstahl mit Kunststoffmantel
- ▶ Lieferung einzeln verpackt

- ▶ Silicate lenses, binocular, interchangeable
- ▶ Fold back frame for lenses
- ▶ White-lacquered metal housing
- ▶ Steel strip headband with plastic jacket
- ▶ Delivered in individual packages

A = ca. Arbeitsabstand

A = approx. working distance

2159 1.. :

Kopfbandlupe inkl. Optik

2159 1.. :

Headband magnifier incl. lenses

2159 2.. :

Wechseloptik

2159 2.. :

Exchangeable lenses

	1x	1,5x	2x	2,5x	3x	3,5x
A mm	250	220	170	150	130	100
⊞ kg	0,11	0,11	0,11	0,11	0,11	0,11
Nº	2159 101	2159 102	2159 103	2159 104	2159 105	2159 106
Nº	2159 201	2159 202	2159 203	2159 204	2159 205	2159 206



No. 2159 1..



No. 2159 2..

## Uhrmacherlupen „Tech-Line“

## Watchmaker´s magnifiers „Tech-Line“



- ▶ Silikatlinse aplanatisch
- ▶ Kunststofffassung schwarz mit Lüftungslloch
- ▶ Lieferung einzeln verpackt

- ▶ Aplanatic silicate lens
- ▶ Black plastic mount with ventilation hole
- ▶ Delivered in individual packages

2190 1.. :

Uhrmacherlupen, einzeln

2190 1.. :

Watchmaker´s magnifiers, single

2190 201 :

Uhrmacherlupen, Satz 4-fg.

2190 201 :

Watchmaker´s magnifiers, set 4 pcs.

	6x	8x	10x	15x	6x / 8x / 10x / 15x
Linsen / Lenses Ømm	22,8	22,8	22,8	16,3	22,8 / 16,3
⊞ kg	0,005	0,005	0,005	0,005	0,5
Nº	2190 101	2190 102	2190 103	2190 104	2190 201



No. 2190 101



No. 2190 201

## Fadenzähler

## Linen testers



- ▶ Silikatlinse bikonvex
- ▶ Messing, mattverchromt
- ▶ Lieferung einzeln verpackt

- ▶ Biconvex silicate lens
- ▶ Satin chrome brass frame
- ▶ Delivered in individual packages

2161 1.. :

Fadenzähler

2161 1.. :

Linen testers

2162 1.. :

Ledertasche

2162 1.. :

Leather bag

	Linsen / Lenses Ømm	Ausschnitt / Cut-out mm	⊞ mm	⊞ kg	Nº	Nº
12x	12,5	10x10	23	0,05	2161 101	2162 101
10x	14,5	15x15	27	0,05	2161 102	2162 102
8x	17,5	20x20	33	0,06	2161 103	2162 103
6x	22,5	25x25	42	0,07	2161 104	2162 104
5x	31,5	30x30	53	0,07	2161 105	2162 105

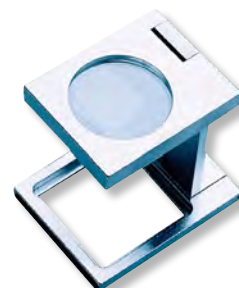

No. 2161 103

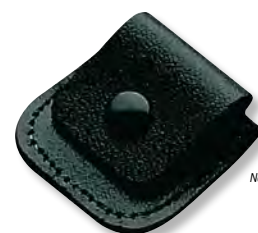

No. 2162 103



**Fadenzähler mit Messkala**

**Linens testers with scale**



- ▶ Silikatlinse aplanatisch
- ▶ Messing, mattverchromt
- ▶ runder Ausschnitt
- ▶ Messskala Ablesung 0,1mm, Länge 10mm
- ▶ Lieferung einzeln verpackt

- ▶ Aplanatic silicate lens
- ▶ Satin chrome brass frame
- ▶ Round cut-out
- ▶ Measuring scale reading 0.1mm, length 10mm
- ▶ Delivered in individual packages

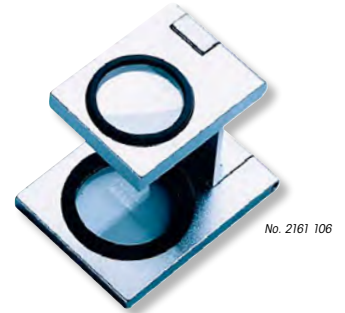

No. 2161 106

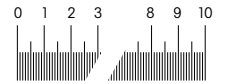

Ablesung / Reading 0,1mm

	Linsen / Lenses Ømm	Ausschnitt / Cut-out Ømm	□ mm	⚖ kg	Nº
8x	16,3	20	35	0,06	<b>2161 106</b>
Ledertasche / Leather bag					<b>2162 103</b>

**Klapp Lupen mit 2 Linsen**

**Folding magnifiers with 2 lenses**



- ▶ Silikatglaslinsen plankonvex, bei kombinierter Nutzung aplanatisch
- ▶ Gehäuse und Fassung aus Kunststoff schwarz
- ▶ Lieferung einzeln verpackt

- ▶ Silicate glass lenses, plano-convex; in case of combined use aplanatic
- ▶ Black plastic housing and mount
- ▶ Delivered in individual packages



No. 2163 204

**2163 106 :**  
Linsen Ø16,3mm

**2163 106 :**  
Lenses Ø 16.3mm

**2163 205 :**  
Linsen Ø22,8mm

**2163 205 :**  
Lenses Ø 22.8mm

	7x+8x (15x)	10x+10x (20x)
⚖ kg	0,005	0,005
Nº	-	<b>2163 106</b>
Nº	<b>2163 205</b>	-

**Klapp Lupen „Tech-Line“**

**Folding magnifiers „Tech-Line“**



- ▶ Silikatlinse aplanatisch
- ▶ Kunststofffassung schwarz
- ▶ Gehäuse aus rostfreiem Stahl
- ▶ Lieferung einzeln verpackt

- ▶ Aplanatic silicate lenses
- ▶ Black plastic mount
- ▶ Stainless steel housing
- ▶ Delivered in individual packages



No. 2191 103

**2191 1..:**  
Klapp Lupen, einzeln

**2191 1..:**  
Folding magnifiers, single

**2191 201 :**  
Klapp Lupen, Satz 4-tlg.

**2191 201 :**  
Folding magnifiers, set 4 pcs.

	6x	8x	10x	15x	20x	6x / 10x / 15x / 20x
Linsen / Lenses Ømm	22,8	22,8	22,8	22,8	16,3	22,8 / 16,3
⚖ kg	0,005	0,005	0,005	0,005	0,005	0,5
Nº	<b>2191 101</b>	<b>2191 102</b>	<b>2191 103</b>	<b>2191 104</b>	<b>2191 105</b>	<b>2191 201</b>



No. 2191 201

## Klapplupe „Tech-Line“ mit mehreren Linsen

## Folding magnifiers „Tech-Line“ with several lenses



- ▶ Silikatglaslinse Ø38mm bikonvex
- ▶ Kunststofffassung schwarz
- ▶ Gehäuse aus rostfreiem Stahl
- ▶ Lieferung einzeln verpackt, inkl. Lanyard

- ▶ Biconvex silicate lenses Ø38mm
- ▶ Black plastic mount
- ▶ Stainless steel housing
- ▶ Delivered in individual packages, incl. lanyard



	3x + 5x = 8x	3x + 3x + 3x = 9x
	0,005	0,005
<b>Nº</b>	<b>2191 301</b>	<b>2191 302</b>

## Standlupe

## Stand magnifiers



- ▶ Leichtlinse aplanatisch
- ▶ Kunststoffgehäuse rund
- ▶ Standfuß transparent
- ▶ Lieferung einzeln verpackt

- ▶ Light lenses, aplanatic
- ▶ Round plastic housing
- ▶ Transparent base
- ▶ Delivered in individual packages



No. 2165 102

No. 2165 103

	Linsen / Lenses Ø mm	⊞ mm		<b>Nº</b>
4x	60	60	0,05	<b>2165 102</b>
10x	30	50	0,04	<b>2165 103</b>

## Messlupe mit Skala

## Measuring magnifiers with scale



- ▶ Leichtlinse achromatisch, fokussierbar
- ▶ Kunststoffgehäuse rund
- ▶ Messskala Ablesung 0,1mm, Länge 10mm
- ▶ Lieferung einzeln verpackt

- ▶ Light lenses, achromatic, focusable
- ▶ Round plastic housing
- ▶ Measuring scale reading 0.1mm, length 10mm
- ▶ Delivered in individual packages



No. 2166 101

	Linsen / Lenses Ø mm	⊞ mm		<b>Nº</b>
10x	15	40	0,03	<b>2166 101</b>

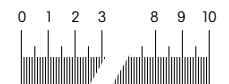

Ablesung / Reading 0,1mm

## Messlupe mit Skala Präzisionsausführung

## Measuring magnifiers with scale precision model



- ▶ Silikatglaslinse aplanatisch, fokussierbar
- ▶ Gehäuse aus Metall
- ▶ Messskala aus rostfreiem Stahl, Ablesung 0,1mm
- ▶ Lieferung einzeln verpackt

- ▶ Silicate glass lenses, aplanatic, focusable
- ▶ Metal housing
- ▶ Stainless steel measuring scale, reading 0.1mm
- ▶ Delivered in individual packages

**A = Skalenlänge**

**A = scale length**

	Linsen / Lenses Ø mm	A mm		<b>Nº</b>
6x	22,8	20	0,04	<b>2166 201</b>
8x	22,8	10	0,04	<b>2166 202</b>
10x	22,8	10	0,04	<b>2166 203</b>

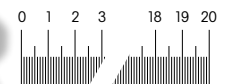

No. 2166 201

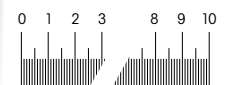

No. 2166 202 / 2166 203

Ablesung / Reading 0,1mm

**Standlupen „Tech-Line“**

**Stand magnifiers „Tech-Line“**



- ▶ Silikatlinsen aplanatisch
- ▶ Kunststoffgehäuse rund
- ▶ Standfuß transparent
- ▶ auswechselbare Messskala optional
- ▶ Lieferung einzeln verpackt

- ▶ Aplanatic silicate lens
- ▶ Round plastic housing
- ▶ Transparent base
- ▶ Interchangeable measuring scale optional
- ▶ Delivered in individual packages

**2192 1.. :**  
Fix-Focus, Linsen Ø 30mm

**2192 1.. :**  
Fix-Focus, Lenses Ø 30mm

**2192 2.. :**  
Vario-Focus, Linsen Ø 22,8mm

**2192 2.. :**  
Vario-Focus, Lenses Ø 22.8mm

	8x	10x
 kg	0,05	0,05
Nº	2192 101	2192 102
Nº	2192 201	2192 202



No. 2192 101



No. 2192 201

**Sonderskalen für Standlupen „Tech-Line“**

**Special scales for stand magnifiers „Tech-Line“**



- ▶ 2 Skalen auf einer Glasplatte (Makro-Skala Ø25mm, Mikro-Skala Ø2,5mm)
- ▶ Kratzfestes Glas
- ▶ Lieferung einzeln verpackt

- ▶ 2 scales in one (macro-scale Ø25mm, micro-scale Ø2.5mm)
- ▶ Scratch resistant glass
- ▶ Delivered in individual packages

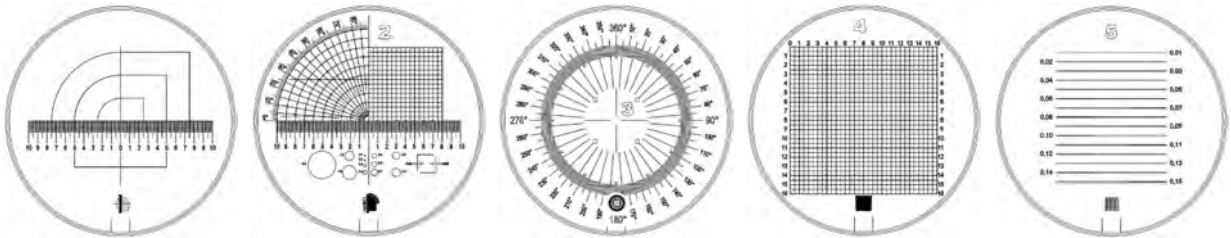

Nº	2192 501	2192 502	2192 503	2192 504	2192 505
----	----------	----------	----------	----------	----------

**LED-Beleuchtungseinheit für Standlupen „Tech-Line“**

**LED-Illumination unit for stand magnifiers „Tech-Line“**



- ▶ Lieferung einzeln verpackt

- ▶ Delivered in individual packages



No. 2193 501

Typ / Type	Nº
LED-Beleuchtungseinheit / LED-Illumination unit	2193 501

## Taschenmikroskope „Tech-Line“

## Pocket microscopes „Tech-Line“



- ▶ Linsensystem achromatisch, fokussierbar
- ▶ einstellbare Vergrößerung
- ▶ Gehäuse aus Metall
- ▶ Lieferung in Kunstledertasche

- ▶ Achromatic lens system, focusable
- ▶ Adjustable magnification
- ▶ Metal housing
- ▶ Delivered in imitation leather bag

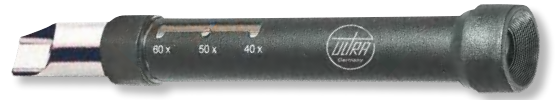

No. 2193 101

	$\text{mm}$	$\text{kg}$	Nº
40x / 50x / 60x	150	0,08	2193 101

## Stand-Adapter für Taschenmikroskope „Tech-Line“

## Stand-Adapter for pocket microscopes „Tech-Line“



- ▶ Sorgt für sicheren Stand eines Taschenmikroskop über dem Prüfobjekt
- ▶ Sonderskalen Nr. 2192 5.. einsetzbar
- ▶ In LED-Beleuchtungseinheit Nr. 2193 501 einsetzbar
- ▶ Gehäuse aus transparentem Kunststoff
- ▶ Lieferung einzeln verpackt, ohne Mikroskop

- ▶ Ensures that the pocket microscope is securely positioned above the object
- ▶ Special scales no. 2192 5.. suitable
- ▶ Suitable with LED-illumination unit no. 2193 501
- ▶ Transparent plastic housing
- ▶ Delivered in individual packages, without microscope



No. 2193 511

Typ / Type	Nº
Stand-Adapter	2193 511

## Sonderskalen für Taschenmikroskope „Tech-Line“

## Special scales for pocket microscopes „Tech-Line“



- ▶ 2 Skalen auf einer Glasplatte (Makro-Skala Ø25mm, Mikro-Skala Ø2,5mm)
- ▶ Kratzfestes Glas
- ▶ Lieferung einzeln verpackt

- ▶ 2 scales in one (macro-scale Ø25mm, micro-scale Ø2,5mm)
- ▶ Scratch resistant glass
- ▶ Delivered in individual packages



Nº	2192 501	2192 502	2192 503	2192 504	2192 505
----	----------	----------	----------	----------	----------

## LED-Beleuchtungseinheit für Taschenmikroskope „Tech-Line“

## LED-illumination unit for pocket microscopes „Tech-Line“



- ▶ Lieferung einzeln verpackt, ohne Mikroskop

- ▶ Delivered in individual packages, without microscope

Typ / Type	Nº
LED-Beleuchtungseinheit / LED-illumination unit	2193 501



No. 2193 501

**Griff Lupen „Tech-Line“**

**Grip magnifiers „Tech-Line“**



- ▶ Silikatlinse aplanatisch
- ▶ Lieferung einzeln verpackt

- ▶ Silicate lens, aplanatic
- ▶ Delivered in individual packages

**2194 1.. :**  
Fassung und Griff aus Kunststoff

**2194 1.. :**  
Plastic mount and grip

**2194 2.. :**  
Fassung und Griff aus Metall

**2194 2.. :**  
Metal mount and grip

	Linsen / Lenses Ø mm	Linsenart / Lenses execution	kg	Nº
2x / 4x	90/20	bikonvex / biconvex	0,06	<b>2194 101</b>
4x	65	aplanatisch / aplanatic	0,06	<b>2194 102</b>
8x	28	aplanatisch / aplanatic	0,06	<b>2194 201</b>
10x	28	aplanatisch / aplanatic	0,07	<b>2194 202</b>



**Lesegläser**

**Reading magnifiers**



- ▶ Silikatlinse bikonvex
- ▶ Metallfassung mit Kunststoffgriff
- ▶ Lieferung einzeln verpackt

- ▶ Silicate lens, biconvex
- ▶ Metal mount with plastic handle
- ▶ Delivered in individual packages

**2168 1.. :**  
Lesegläser

**2168 1.. :**  
Reading magnifiers

**2170 106 :**  
Ledertasche

**2170 106 :**  
Leather bag

	Linsen / Lenses mm	kg	Nº	Nº
3,5x	Ø 65	0,1	<b>2168 101</b>	<b>2170 106</b>
2,5x	Ø 75	0,13	<b>2168 102</b>	
2x	Ø 100	0,22	<b>2168 103</b>	



**Standlesegläser „Tech-Line“**

**Stand magnifiers „Tech-Line“**



- ▶ Silikatlinse aplanatisch
- ▶ Metallfassung mit Anlaufschutz
- ▶ Flexibler Metallarm 300mm
- ▶ Standfuß aus Guss, lackiert
- ▶ Lieferung einzeln verpackt

- ▶ Silicate lens aplanatic
- ▶ Metal mount with anti-fogging coat
- ▶ Flexible metal arm 300mm
- ▶ Lacquered cast iron base
- ▶ Delivered in individual packages

**2195 101 :**  
bifokale Linse

**2195 101 :**  
bifocal lenses

**2195 102 :**  
bikonvexe Linse

**2195 102 :**  
Biconvex lenses

	Linsen / Lenses Ø mm	kg	Nº
2x / 4x	90/20	1,5	<b>2195 101</b>
4x	65	1,0	<b>2195 102</b>



## Handleuchtlupen mit LED „Tech-Line“

## Hand held illuminated magnifiers with LED „Tech-Line“



- ▶ Silikatglaslinse
- ▶ Kunststofffassung mit Metallgriff
- ▶ Lieferung einzeln verpackt ohne Batterien

- ▶ Silicate glass lens
- ▶ Plastic mount with metal handle
- ▶ Delivered in individual packages without batteries

	Linsen / Lenses Ø mm	Typ Type	⚖ kg	Nº
4x	55	asphärisch / aspherical	0,3	2196 101
8x	30	aplanatisch / aplanatic	0,3	2196 102
10x	30	aplanatisch / aplanatic	0,3	2196 103



No. 2196 101

No. 2196 102

## Handleuchtlupen mit LED

## Hand held illuminated magnifiers with LED



- ▶ Silikatglaslinse
- ▶ Gehäuse aus Kunststoff
- ▶ Lieferung einzeln verpackt ohne Batterien

- ▶ Silicate glass lens
- ▶ Plastic housing
- ▶ Delivered in individual packages without batteries

	Linsen / Lenses Ø mm	Typ Type	⚖ kg	Nº
2x / 4x	70 / 20	bifokal / bifocal	0,2	2176 300
4x	55	asphärisch / aspherical	0,2	2176 301
6x	30	aplanatisch / aplanatic	0,2	2176 302
8x	30	aplanatisch / aplanatic	0,2	2176 303
10x	22,8	aplanatisch / aplanatic	0,2	2176 304
15x	16,3	aplanatisch / aplanatic	0,2	2176 306



No. 2176 301

No. 2176 303

## Ring-Lupenleuchten mit Federgelenkarm

## Circular illuminated magnifiers with spring balanced arm



- ▶ Silikatglaslinse, bikonvex
- ▶ Lupenkopf aus Metall
- ▶ Ringleuchtstofflampe 22W/840
- ▶ Federgelenkarm ca. 900mm mit Tischklemme
- ▶ Zuleitung 1,5m mit Schuckostecker
- ▶ Stromversorgung 230V
- ▶ Energieeffizienzklasse B (kWh/1000h = 27)
- ▶ Lieferung einzeln verpackt inkl. Linsenabdeckung

- ▶ Silicate glass lens, biconvex
- ▶ Metal lens rim
- ▶ Ring fluorescent lamp 22W/840
- ▶ Spring balanced arm approx. 900mm with table clamp
- ▶ Main lead 1.5m with schuko plug
- ▶ Power supply 230V
- ▶ Energy efficiency class B (kWh/1000h = 27)
- ▶ Delivered in individual packages incl. lens cover

Dioptrien Diopters		Linsen / Lenses Ø mm	⚖ kg	Nº
3	1,75x	120	3,9	2184 101
5	2,25x	120	4,0	2184 202
Ersatzleuchtmittel / Replacement lamp				2184 301
schwerer Standfuß (7.5kg) / Heavy base (7.5kg)				2184 402-1
Befestigungsflansch / Clamping collar				2184 404



No. 2184 101

**Ring-Lupenleuchte LED  
mit Federgelenkarm**

**Circular illuminated magnifiers LED  
with spring balanced arm**



★ **NEW**

- ▶ Silikatglaslinse, bikonvex
- ▶ Lupenkopf aus Aluminium-Druckguss
- ▶ Ring aus 21W LED´s, Gesamt 8W
- ▶ Federgelenkarm ca. 960mm mit Tischklemme
- ▶ Zuleitung 2m mit Eurostecker
- ▶ Dimmfunktion durch integriertem Bedientaster
- ▶ Energieeffizienzklasse A+ (9kWh/1000h)
- ▶ Stromversorgung 100 – 240V~/50 – 60Hz
- ▶ Lieferung einzeln verpackt, inkl. Linsenabdeckung

- ▶ Silicate glass lens, biconvex
- ▶ Aluminium-die cast metal lens ring
- ▶ Ring with 21W LED´s, complete 8W
- ▶ Spring balanced arm approx. 960mm with table clamp
- ▶ Main lead 2m with europlug
- ▶ Dim function through integrated button
- ▶ Energy efficiency class A+ (9kWh/1000h)
- ▶ Power supply 100 – 240V~/50 – 60Hz
- ▶ Delivered in individual packages, incl. lens cover



No. 2186 101

Dioptrien Diopters		Linsen / Lenses mm	kg	Nº
3	1,75x	120	2,0	2186 101
schwerer Standfuß (7,5Kg) / Heavy base (7,5Kg)				2184 402-1
Befestigungsflansch / clamping collar				2184 404

**Großfeld-Lupenleuchten LED  
mit Reibungsgelenkarm**

**Large field illuminated magnifiers LED  
with friction arm**



★ **NEW**

- ▶ Silikatglaslinse, geschliffene Präzisionsoptik
- ▶ Lupenkopf aus Kunststoff
- ▶ Reibungsgelenkarm mit Federunterstützung 730mm
- ▶ Zuleitung 1,5m mit Schuckostecker
- ▶ Stromversorgung 230V
- ▶ Energieeffizienzklasse A++ (7kWh/1000h)
- ▶ Lieferung einzeln verpackt  
inkl. Linsenabdeckung, Befestigung separat bestellen

- ▶ Silicate glass, precision ground lenses
- ▶ Plastic lens rim
- ▶ Friction arm with additional integral springs 730mm
- ▶ Main lead 1.5m with schuko plug
- ▶ Power supply 230V
- ▶ Energy efficiency class A++ (7kWh/1000h)
- ▶ Delivered in individual packages  
incl. lens cover; fastener to be ordered separately



No. 2187 102

Dioptrien Diopters		Linsen / Lenses mm	kg	Nº
3	1,75x	171x108	3,8	2187 102
Ersatz LED-Lampe / Replacement LED lamp				2187 302
Tischklemme / Table clamp				2184 401
schwerer Standfuß (10,5kg) / Heavy base (10,5kg)				2184 402-2
Befestigungsflansch / Clamping collar				2184 404

1  
2  
3  
4  
5  
6  
7  
8  
9  
10  
11  
12  
13  
14  
15

## Parallel-Endmaße DIN EN ISO 3650 (vorher DIN 861)

### Genauigkeitsgrad und empfohlene Verwendung:

**Genauigkeit K** Urmaß als absolute Maßverkörperung im Feinmessraum.  
**Genauigkeit 0** zur Kontrolle von Messmitteln und zum Einstellen hochgenauer Messgeräte.

**Genauigkeit 1** zur Kontrolle von Prüfmaßen, zum Einstellen von Messmitteln und als hochgenaues Arbeitsmaß.

**Genauigkeit 2** Einstellmaß und Arbeitsmaß für die Fertigung.

**Querschnitt:** 0,5 – 10mm = 30x9mm  
 > 10mm = 35x9mm

### Materialeigenschaften im Vergleich: (Die Angaben sind ca. Werte)

Eigenschaften Properties	Stahl Steel	Hartmetall Tungsten carbide	Keramik Ceramic
Längenausdehnungskoeffizient Coefficient of expansion	$11 \pm 1 \times 10^{-6} / K^{-1}$	$4,6 \times 10^{-6} / K^{-1}$	$10 \pm 1 \times 10^{-6} / K^{-1}$
Wärmeleitfähigkeit Heat conductivity	hoch High	niedrig Low	sehr niedrig Very low
Härte Hardness	> 63 HRc	1450 – 1500 HV30	1350 HV
Verschleißfestigkeit Wear resistance	gut Good	sehr gut Very good	ausgezeichnet Excellent
Anschubeigenschaften Wringing characteristics	ausgezeichnet Excellent	gut Good	akzeptabel Acceptable
Geometrietreue Geometric fidelity	sehr gut bei korrekter Behandlung Very good with proper handling	ausgezeichnet Excellent	ausgezeichnet Excellent
Korrosionsbeständigkeit Corrosion resistance	weniger gut Satisfactory	gut Good	ausgezeichnet Excellent
Mechanische Festigkeit Mechanical stability	sehr gut Very good	gut Good	gut Good

## Gauge blocks DIN EN ISO 3650 (previously DIN 861)

### Accuracy grade and recommended use:

**Accuracy grade K** Primary standard as absolute master gauge in the laboratory  
**Accuracy grade 0** For testing measuring devices and setting up high-precision gauges

**Accuracy grade 1** For testing check gauges, setting up measuring devices and as working dimension

**Accuracy grade 2** Setting and working dimensions for production

**Cross section:** 0,5 – 10mm = 30x9mm  
 > 10mm = 35x9mm

### Material properties in comparison: (The data are approx. values)

### Zulässige Abweichungen und Toleranzen DIN EN ISO 3650:

te = zulässige Abweichung vom Nennmaß an beliebiger Stelle  
 tv = Toleranz für die Abweichungsspanne

### Permissible deviations and tolerances DIN EN ISO 3650:

te = Permissible deviation of nominal size at any position  
 tv = Tolerance for the deviation range

-  mm über / over bis / up to		±t <sub>e</sub> μ  K		±t <sub>e</sub> μ  0		±t <sub>e</sub> μ  1		±t <sub>e</sub> μ  2	
		t <sub>v</sub> μ	t <sub>v</sub> μ	t <sub>v</sub> μ	t <sub>v</sub> μ	t <sub>v</sub> μ	t <sub>v</sub> μ	t <sub>v</sub> μ	t <sub>v</sub> μ
0	10	0,20	0,05	0,12	0,10	0,20	0,16	0,45	0,30
10	25	0,30	0,05	0,14	0,10	0,30	0,16	0,60	0,30
25	50	0,40	0,06	0,20	0,10	0,40	0,18	0,80	0,30
50	75	0,50	0,06	0,25	0,12	0,50	0,18	1,00	0,35
75	100	0,60	0,07	0,30	0,12	0,60	0,20	1,20	0,35
100	150	0,80	0,08	0,40	0,14	0,80	0,20	1,60	0,40
150	200	1,00	0,09	0,50	0,16	1,00	0,25	2,00	0,40
200	250	1,20	0,10	0,60	0,16	1,20	0,25	2,40	0,45
250	300	1,40	0,10	0,70	0,18	1,40	0,25	2,80	0,50
300	400	1,80	0,12	0,90	0,20	1,80	0,30	3,60	0,50
400	500	2,20	0,14	1,10	0,25	2,20	0,35	4,40	0,60
500	600	2,60	0,16	1,30	0,25	2,60	0,40	5,00	0,70
600	700	3,00	0,18	1,50	0,30	3,00	0,45	6,00	0,70
700	800	3,40	0,20	1,70	0,30	3,40	0,50	6,50	0,80
800	900	3,80	0,20	1,90	0,35	3,80	0,50	7,50	0,90
900	1000	4,20	0,25	2,00	0,40	4,20	0,60	8,00	1,00

### Kalibrierung:

Endmaße aus Stahl, Hartmetall und Keramik können mit einem Werkskalibrierschein oder DAkkS-Kalibrierschein eines akkreditierten Labors geliefert werden.

Bitte beachten Sie hierzu unsere Sonderpreise für Endmaßsätze inkl. DAkkS-Kalibrierschein oder Werkskalibrierschein. Die Bestellnummern sind in diesem Fall zusätzlich mit "p" gekennzeichnet.

Weitere Informationen erhalten Sie außerdem unter:  
[www.ultra-germany.com](http://www.ultra-germany.com) > Produkte > Service > Prüfmittelüberwachung

### Calibration:

Gauge blocks made of steel, tungsten carbide and ceramic can be delivered with a works calibration certificate or a DAkkS calibration certificate of an accredited laboratory.

Please note that our special prices for gauge block sets include the DAkkS or works calibration certificate. The order numbers are additionally marked with "p" in this case.

More information can be had at:  
[www.ultra-germany.com](http://www.ultra-germany.com) > Products > Service > Calibration



**Rundpassungslehren**

**Material- und Schichteigenschaften von Lehren im Vergleich:**

Die Angabe der Verschleißfestigkeit erfolgt im Vergleich zu Lehrenstahl und kann nur als ca. ± Richtwert angenommen werden, da diese Werte von Umgebungsbedingungen und Werkstückmaterialien beeinflusst werden können.

Eigenschaften Properties	Lehrenstahl Steel	Hartchrom Hard chrome	TIN (gold) TiN (gold)	TICN (violet) TiCN (violet)	Hartmetall Tungsten carbide
Härte Hardness	62 HRC +/- 2	900 HV	2500 HV	3000 HV	1800 HV
Verschleißfestigkeit Wear resistance	1x	5x	10x	15x	40x
Korrosionsbeständigkeit Corrosion resistance	weniger gut Satisfactory	gut Good	sehr gut Very good	sehr gut Very good	sehr gut Very good

**Toleranzen:**

Es werden Arbeitslehren (mit Abnutzungsaufmaß auf der Gutseite) geliefert, wenn nicht abweichend bestellt.  
 Die Abmaße für Rundpassungslehren werden in der Regel nach dem ISO-Toleranzfeld für Bohrungen und Wellen angegeben.  
 Toleranzangaben für Grenzlehndorne werden in Großbuchstaben (H7, J8 usw.) angegeben.  
 Toleranzangaben für Rachenlehren werden in Kleinbuchstaben (f7, k6 usw.) angegeben.  
 Bitte geben Sie bei Ihrer Bestellung die entsprechende ISO-Passung oder eine zahlenmäßige Toleranz an.

**Zwischenmaßregelung:**

Für Zwischenmaße, zahlenmäßige Toleranzangaben, Qualität 6 und feiner sowie Abnahmelehren (ohne Abnutzungsaufmaß) werden Zuschläge berechnet.

**Sonderausführungen auf Anfrage:**

- TIN und TiCN beschichtete oder hartverchromte Lehren
- hartmetallbestückte Messflächen
- Kugellehren
- Lehren nach Kundenzeichnung

**Kalibrierung:**

Für alle Lehren können Werkskalibrierscheine erstellt werden.  
 Eine DAkkS-Kalibrierung durch ein akkreditiertes Labors ist für viele Lehrentypen ebenfalls möglich.  
 Bitte beachten Sie hierzu unsere Nettopreisliste für die Erstellung von Prüfberichten.

Weiter Informationen erhalten Sie unter:

[www.ultra-germany.com](http://www.ultra-germany.com) > **Produkte** > **Service** > **Prüfmittelüberwachung**

**Kundenschnellservice:**

Mit diesem Service ermöglichen wir für Lehren extrem kurze Lieferzeiten gegenüber der üblichen Standard-Lieferzeit. Die Fertigung erfolgt in der Regel in Überstunden. Für diese besondere Leistung werden entsprechende Zuschläge zu den Grundpreisen berechnet.

Die Möglichkeit für einen Schnellservice muss im Einzelfall für jede gewünschte Lehre geprüft werden.

Bitte vermerken Sie hierzu in Ihrer Anfrage „Lieferung im Kundenschnellservice“ und Ihren Wunschtermin.

**Grenzlehndorne mit Sondermessflächen:**

Wir liefern Grenzlehndorne mit besonderen Messflächenformen, auch nach Ihren Zeichnungen.

Zur Angebotserstellung bitten wir um die Zusendung Ihrer Anfrage mit Prinzipskizze.

**Beispiele für mögliche Sonderformen:**

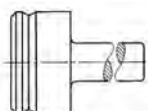

Messzapfen mit Pilotieransatz DIN 6338  
 Plug gauge with pilot easy entry DIN 6338

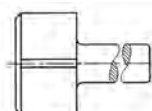

Messzapfen mit Luftnute  
 Plug gauge with air groove

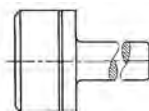

Messzapfen mit Tiefenmarkierung  
 Plug gauge with depth mark



Messzapfen in Sonderlänge  
 Plug gauge in special length

**Cylindrical limit gauges**

**Material and coat properties of gauges in comparison:**

The specification of wear resistance is carried out in relation to tool steel and can only be considered as a rough recommended value ±, since these values can be significantly influenced by environmental conditions and workpiece materials.

**Tolerances:**

We supply working gauges (with wear allowance on GO-side) if not ordered different.  
 The limit of tolerances for cylindrical limit gauges is stated generally according to the ISO tolerance class for shafts and holes.  
 Tolerance specifications for limit plug gauges are given in capitals (H7, J8, etc.).

Tolerance specifications for snap gauges are given in lower type (f7, k6, etc.). Please specify the corresponding ISO tolerance or a numerical tolerance in your order.

**Provision for intermediate sizes:**

Intermediate dimensions, numerical tolerances, quality 6 and finer, as well as check gauges (without wear allowance) have extra charge.

**Special models on request:**

- TIN and TiCN-coated or hard chrome-plated gauges
- Ball gauges
- Tungsten carbide-tipped measuring faces
- Gauges according to customer's drawing

**Calibration:**

Works calibration certificates can be issued for all gauges.  
 A DAkkS calibration from an accredited laboratory is likewise provided for many gauge types.  
 Please note our net price list for the preparation of calibration certificates.

Further information at:

[www.ultra-germany.com](http://www.ultra-germany.com) > **Products** > **Service** > **Calibration**

**Customer express service:**

We offer extremely short delivery times with this service compared to the usual standard delivery time. In general, the production is manufactured in overtime. An appropriate extra fee is added to the basic price for this special service.

The possibility for an express service must be checked in individual cases especially for each desired gauge.

Please mark your enquiry with "To be delivered in Customer Express Service" and mention your desired date.

**Limit plug gauges with special measuring faces:**

We supply limit plug gauges with special measuring faces and also according to your drawings.

For the preparation of a quotation, we request you to send your inquiry with a schematic drawing.

**Example for possible special designs:**

## Gewindelehren

### Allgemeine Informationen und Bestellhinweise:

Die im Katalog geführten Gewindearten und Größen sind ein kleiner Auszug aus unserem umfassenden Lieferprogramm für Gewindelehren. Andere Abmessungen und Gewindesteigungen finden Sie in unserer Preisliste für Gewindelehren. Grenzgewindelehndorne bis Ø 40mm werden in der Regel mit Gutseite und Ausschussseite in einem Griff geliefert. Darüber erfolgt die Lieferung mit je einem Griff für Gutseite und Ausschussseite. Unsere Listenpreise beziehen sich immer auf Arbeitslehren gemäß folgenden Toleranzfeldern:

Linksgewinde sowie andere Toleranzen werden mit Zuschlägen berechnet.

Gewindeart Thread type	Toleranzfeld / Tolerance field		
	Lehrdorne Plug gauges	Lehrringe Ring gauges	Rachen- und Einstelllehren Thread snap and setting gauges
Metrisches ISO Gewinde DIN 13 < M 1,6 ISO metric threads DIN 13 < M 1.6	5H	6h	6h
Metrisches ISO Gewinde DIN 13 ≥ M 1,6 ISO metric threads DIN 13 ≥ M 1.6	6H	6g	6g
Whitworth Regelgewinde BS 84 Whitworth standard thread BS 84	medium class	medium class	medium class
Whitworth Feingewinde BS 84 Whitworth fine thread BS 84	medium class	medium class	medium class
Whitworth Rohrgewinde DIN ISO 228 Whitworth pipe thread DIN ISO 228	Mittel / Medium	A	A
Trapezgewinde DIN 103 Trapezoidal screw thread DIN 103	7H	7e	7e
Rundgewinde DIN 405 Knuckle thread DIN 405	7H	7h	-
UNC / UNF / UNEF Gewinde ANSI (BS 919) UNC / UNF / UNEF thread ANSI (BS 919)	2B	2A	2A

### Sonderausführungen auf Anfrage:

- TIN und TiCN beschichtete oder hartverchromte Gewindelehren
- Einzelne Gut- oder Ausschussgewindelehndorne sowie Gewinderollenrachenlehren und Einstelllehren
- Messzapfen mit Schmutznute
- Minimum-, Maximum- und Abnutzungsprüfdorne
- Mehrgängige Gewinde und Sondergewinde nach Zeichnung

### Prüfung von Gewindelehrringen

Die in den Lehren-Normen angegebenen Flankendurchmesser und Toleranzen für neue feste Gewindelehrringe gelten nicht, wenn die Gewindelehrringe wie üblich nach Prüfdornen gefertigt werden. Sollen jedoch die Ringe im Flankendurchmesser direkt gemessen werden, gelten die in den Normen festgelegten Sollmaße und Toleranzen. Für diesen Fall muss dies bei der Bestellung von Gewindelehrringen ausdrücklich angegeben werden. Eine spätere Beanstandung oder Reklamation wird nicht akzeptiert.

### Kalibrierung:

Gewindelehren können mit einem Werkskalibrierschein oder DAkkS-Kalibrierschein eines akkreditierten Labors geliefert werden.

Bitte beachten Sie hierzu unsere Nettopreisliste für die Erstellung von Prüfberichten.

Weiter Informationen erhalten Sie unter:

[www.ultra-germany.com](http://www.ultra-germany.com) > Produkte > Service > Prüfmittelüberwachung

### Kundenschnellservice:

Mit diesem Service ermöglichen wir für Lehren extrem kurze Lieferzeiten gegenüber der üblichen Standard-Lieferzeit. Die Fertigung erfolgt in der Regel in Überstunden. Für diese besondere Leistung werden entsprechende Zuschläge zu den Grundpreisen berechnet.

Die Möglichkeit für einen Schnellservice muss im Einzelfall für jede gewünschte Lehre geprüft werden.

Bitte vermerken Sie hierzu in Ihrer Anfrage „Lieferung im Kundenschnellservice“ und Ihren Wunschtermin.

## Thread gauges

### General and ordering information:

The thread gauge types and sizes listed in the catalogue are a brief summary of our comprehensive thread gauge product range. Other dimensions and thread pitches can be found in our thread gauge price list. Limit thread plug gauge up to Ø 40 mm are usually supplied with GO and NO-GO sides in one handle; one handle each for GO and NO-GO side is supplied for larger diameters.

Our listed prices always refer to the workshop gauges in accordance with the following tolerance fields:

Left hand threads and other tolerances have extra charges.

### Special designs on request:

- TIN- and TiCN-coated or hard chrome-plated thread gauges
- Individual GO or NO-GO plug thread gauges, thread snap gauges with rollers and thread setting gauges
- Gauge member with dust groove
- Minimum, maximum and wear test plug gauges
- Multistart and special threads according to drawings

### Testing of thread ring gauges

The pitch diameter and tolerances given in the gauge standards are not applicable for newly fixed thread ring gauges, if these ring gauges are, as is customary, manufactured according to test plug gauges. In case the rings are directly measured in the pitch diameter, the specified sizes and tolerances given in the standards are applicable. In such a case, this must be explicitly stated in the order for thread ring gauges. A subsequent complaint or claim will not be accepted.

### Calibration:

Thread gauges can be supplied with a works calibration certificate or DAkkS calibration certificate of an accredited laboratory.

Please take note of our net price list for the preparation of calibration reports.

Further information can be had at:

[www.ultra-germany.com](http://www.ultra-germany.com) > Products > Service > Calibration

### Customer express service:

We offer extremely short delivery times with this service compared to the usual standard delivery time. In general, the production is manufactured in overtime. An appropriate extra fee is added to the basic price for this special service.

The possibility for an express service must be checked in individual cases especially for each desired gauge.

Please mark your enquiry with "To be delivered in Customer Express Service" and mention your desired date.

**Digital-Messuhren**

überzeugen durch hohe Genauigkeit und robuste, mechanische Komponenten. Die Herstellung erfolgt nach Werksnorm. Für besondere Einsatzbedingungen sind Modelle mit Schutzart IP 65 lieferbar.

**Feinzeiger mit Skala**

bieten ein Größtmaß an Präzision und Messsicherheit. Die Zeigerfeineinstellung ist feinfühlig und zugleich stabil. Alle Modelle sind stoßgeschützt mit zusätzlichem Freihub. Sie entsprechen in allen messtechnischen Merkmalen und Abmessungen der DIN 879-1.

**Messuhren mit Skala**

zeichnen sich durch robuste Konstruktion, hohe Genauigkeit, Zuverlässigkeit und lange Lebensdauer aus. Die messtechnischen Merkmale und Abmessungen aller Modelle mit 0,01 mm Skalenteilungswert, Messspanne bis 10 mm, und Außenring Ø bis 62 mm, entsprechen der DIN 878 bzw. der Werksnorm. Alle anderen Modelle werden nach Werksnormen hergestellt, die wir auf Wunsch gerne zur Verfügung stellen.

**Digital-Fühlhebelmessgeräte**

überzeugen durch höchste Genauigkeit und Zuverlässigkeit. Die Taster sind schwenkbar, eine Rutschkupplung schützt das Geräte gegen Stöße. Die Herstellung erfolgt nach Werksnorm.

**Fühlhebelmessgeräte mit Skala**

haben eine hohe Feinfühligkeit. Die Taster sind schwenkbar, eine Rutschkupplung schützt das Messwerk gegen Stöße. Die Gehäuse sind hartverchromt um Beschädigungen zu vermeiden. Die Herstellung erfolgt nach DIN 2270.

**Kalibrierung:**

Für alle Messuhren und Fühlhebelmessgeräte können Werkskalibrierscheine erstellt werden. Eine DAkkS Kalibrierung durch ein akkreditiertes Labor ist für die meisten Modelle ebenfalls möglich.

Bitte beachten Sie hierzu unsere Nettopreisliste für die Erstellung von Prüfberichten.

Weitere Informationen erhalten Sie unter:

[www.ultra-germany.com](http://www.ultra-germany.com) > Produkte > Service > Prüfmittelüberwachung

**Sonderzifferblätter für Messuhren:**

Viele Modelle aus unserem breiten Sortiment können mit Sonderzifferblättern geliefert werden. Zur Angebotserstellung bitten wir um Ihre Anfrage mit Prinzipskizze.

**Beispiele möglicher Sonderzifferblätter:**



Zifferblätter mit farbigem Toleranzfeld in rot, grün oder gelb

Dial with coloured tolerance fields in red, green or yellow



Zifferblätter linkslaufend beziffert

Dial numeralised from right to left



Zifferblätter beidseitig beziffert

Dial numeralised on both sides



Zifferblätter nach Kundenzeichnung

Dial as per customer drawing

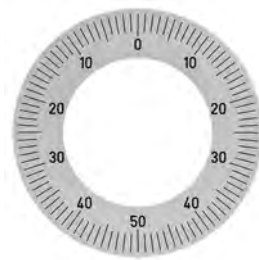
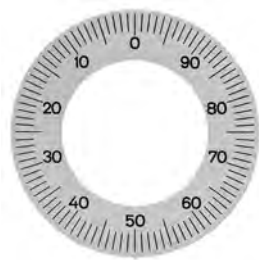

**Digital dial gauges**

Offer surety through high accuracy and robust mechanical components. Manufactured according to company standard. Models with protection class IP 65 can be delivered for special operating conditions.

**Comparator gauges with scale**

Offer the greatest precision and measuring safety. The fine adjustment of the pointer is sensitive and stable at the same time. All models are shock proof with additional overrun. They conform to DIN 879-1 in all metrological characteristics and dimensions.

**Dial gauges with scale**

Distinguish themselves by their robust construction, high accuracy, reliability and long durability. The metrological characteristics and dimensions of all models with 0.01 mm scale interval, measuring range up to 10 mm, and outer ring Ø up to 62 mm, are conform to DIN 878 or works standard. All other models are manufactured according to our company standards, which will be provided on request.

**Digital dial test indicators**

Offer surety through highest accuracy and reliability. The probe is adjustable and a friction clutch protects the device from impacts. Manufactured according to company standard.

**Dial test indicators with scale**

Have a high sensitivity. The probe is adjustable and a friction clutch protects the device from impacts. The housing is hard chrome plated to avoid damages. Manufactured according to DIN 2270.

**Calibration:**

Works calibration certificates can be issued for all dial gauges and dial test indicators. DAkkS calibration certificates from accredited laboratories are likewise issued for most models.

For the issue of calibration reports, please see our net price list.

For further information go to:

[www.ultra-germany.com](http://www.ultra-germany.com) > Products > Service > Calibration

**Special dials for dial gauges:**

Many models in our wide range can be supplied with special dial faces. For the preparation of a quotation, please include schematic drawing in your enquiry.

## ULTRA Keramik-Messtische

Aluminiumoxid ist einer der wichtigsten oxidkeramischen Werkstoffe und wird im Bereich der technischen Keramik in verschiedenen Anwendungsgebieten eingesetzt. Grundlage ist der Rohstoff Bauxit, ein gelbbraunes Sedimentgestein, aus dem Aluminiumoxid durch aufwendige chemische Umwandlungsprozesse gewonnen wird. Die hohe Festigkeit, Härte und Korrosionsbeständigkeit dieses Werkstoffs verleiht den ULTRA Keramik-Messtischen ein Größtmaß an Verschleißfestigkeit und Formstabilität.

### Materialeigenschaften im Vergleich:

Eigenschaften Properties	Keramik Ceramic	Hartgestein Granite	Stahl gehärtet Steel hardened
Längenausdehnungskoeffizient Coefficient of expansion	$7,2 \times 10^{-6} / K$	$5-7,5 \times 10^{-6} / K$	$11,5 \times 10^{-6} / K$
Wärmeleitfähigkeit Heat conductivity	niedrig Low	sehr niedrig Very low	hoch High
Härte Hardness	1600 HV 0,5	6-7 Mohs-Skala 6-7 Mohs' scale	60 HRC +/-2
Verschleißfestigkeit Wear resistance	ausgezeichnet Excellent	sehr gut Very good	sehr gut Very good
Geometrie-treue Geometric fidelity	ausgezeichnet Excellent	ausgezeichnet Excellent	sehr gut bei korrekter Behandlung Very good with proper handling
Korrosionsbeständigkeit Corrosion resistance	ausgezeichnet Excellent	ausgezeichnet Excellent	weniger gut Satisfactory
Mechanische Festigkeit Mechanical stability	gut Good	gut Good	sehr gut Very good

## ULTRA ceramic measuring tables

Aluminium oxide is one of the most important oxide ceramic materials and is used in various application areas in the technical ceramic sector. The basis is the raw material bauxite, a yellow-brown sedimentary rock, which is obtained from aluminium oxide through extensive chemical conversion processes. The high stability, hardness and corrosion resistance of this raw material give maximum wear resistance and shape stability to the ULTRA ceramic measuring tables.

### Material properties in comparison:



Parallel-Feineinstellung,  
Verstellweg ca. 8mm  
Parallel fine adjustment,  
adjusting range approx. 8mm

Messtische mit Keramikmess-  
fläche siehe Seite 5.8  
Measuring tables with ceramic  
surface see page 5.8



Messtische mit Hartgestein-  
messfläche siehe Seite 5.9  
Measuring tables with granite  
surface see page 5.9



Messtische mit Stahlmess-  
fläche siehe Seite 5.10  
Measuring tables with steel  
surface see page 5.10



### Ebenheit der Messflächen nach DIN 876:

Die Berechnung erfolgt nach den in der Tabelle angegebenen Formeln, die Toleranzen sind gerundet.

Länge $a = \text{mm}$	$\text{Ⓜ} 000$ $(1 + a/1000)\mu$	$\text{Ⓜ} 00$ $(2 + a/500)\mu$	$\text{Ⓜ} 0$ $(4 + a/250)\mu$
100	1,5	2,5	4,5
200	1,5	2,5	5
300	1,5	2,5	5,5
400	1,5	3	6

### Flatness of the measuring surfaces according to DIN 876:

The calculation is done as per the formulas specified in the table, the tolerances are rounded off.

### Kalibrierung:

Für alle Messtische können Werkskalibrierscheine erstellt werden. Bitte beachten Sie hierzu unsere Nettopreisliste für die Erstellung von Prüfberichten.

Weiter Informationen erhalten Sie unter:  
[www.ultra-germany.com](http://www.ultra-germany.com) > Produkte > Service > Prüfmittelüberwachung

### Sondermesstische und Stativ:

Wir liefern jede Art von Sondermesstischen und Stativen nach Ihren Zeichnungen – auf Wunsch auch Konzeption und Konstruktion, gegen Berechnung.

Zur Angebotserstellung bitten wir um Ihre Anfragen mit Zeichnungen.

### Calibration:

Works calibration certificates can be issued for all measuring tables. Please check our net price list for the issue of calibration reports.

More information can be had at:  
[www.ultra-germany.com](http://www.ultra-germany.com) > Products > Service > Calibration

### Special measuring tables and stands:

We supply all types of special measuring tables and stands according to your drawings – on request also undertake conception and design at a cost.

For the preparation of a quotation, please send your inquiries with drawings.

**ULTRA Natur-Hartgestein**

Basisches Tiefengestein aus Schweden und Südafrika verfügt über ein besonders dichtes, homogenes Gefüge und eignet sich deshalb hervorragend für die Herstellung von Messmitteln und Maschinenkomponenten. Diese Hartgesteine sind über Millionen von Jahren auf natürliche Weise gealtert und deshalb völlig frei von inneren Spannungen. Sie sind absolut rosticher, säurebeständig, unmagnetisch und elektrisch nichtleitend.

Für ULTRA Hartgestein-Messmittel wird nur ausgesuchtes Material, frei von Fehlern, ohne Einschlüsse und Verwitterungserscheinungen verwendet. Dies garantiert ein Höchstmaß an Formstabilität und Verschleißfestigkeit.

**Folgende Gesteinsarten werden bevorzugt verwendet:**

Gabbro-Impala (Südafrika / South Africa)

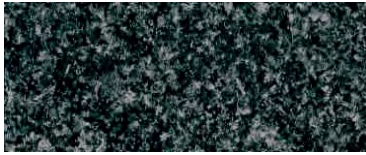

Belfast (Südafrika / South Africa)



Diabas (Schweden / Sweden)



**ULTRA natural granite**

Alkaline plutonic rock from Sweden and South Africa provides a particularly dense homogeneous microstructure and is therefore exceptionally suitable for the manufacture of measuring devices and machine components. These rocks have naturally aged over millions of years and are hence completely free from internal stresses. They are absolutely rust-free, acid-resistant, non-magnetic and electrically nonconducting.

Only select material that is free of defect, without inclusions and appearances of weathering is used for the ULTRA granite measuring devices. This guarantees a high degree of shape stability and wear resistance.

**The following stone types are preferentially used:**

**Materialeigenschaften im Vergleich:**

**Material properties in comparison:**

Eigenschaften Properties	Hartgestein Granite	Gusseisen GG25 Cast iron GG25
Längenausdehnungskoeffizient ca. Coefficient of expansion approx.	5 – 7,5x 10 <sup>-6</sup> / K	9 – 10 x 10 <sup>-6</sup> / K
Wärmeleitfähigkeit Heat conductivity	sehr niedrig Very low	hoch High
Härte Hardness	6 – 7 Mohs-Skala 6 – 7 Mohs' scale	180 – 90 HB
Verschleißfestigkeit Wear resistance	sehr gut Very good	gut Good
Geometrietreue Geometric fidelity	ausgezeichnet Excellent	sehr gut bei korrekter Behandlung Very good with proper handling
Korrosionsbeständigkeit Corrosion resistance	ausgezeichnet Excellent	gut Good
Mechanische Festigkeit Mechanical stability	gut Good	sehr gut Very Good

**Ebenheitstoleranzen nach DIN 876**

Die Ebenheit der Messflächen wird mit folgenden Formeln errechnet: (für Wert a, Länge in mm in die Formel einsetzen)

☐	Formel / Formula
000	(1 + a/1000)μ
00	(2 + a/500)μ
0	(4 + a/250)μ

**Flatness tolerances according to DIN 876**

The flatness of the measuring surfaces is calculated based on the following formulas: (for value a, indicate length in mm in the formula)

☐	Formel / Formula
1	(10 + a/100)μ
2	(20 + a/50)μ
3	(40 + a/25)μ

**ULTRA Hartgestein-Messplattenservice:**

Wir vermessen Ihre Messplatten direkt bei Ihnen Vorort und erstellen einen Kalibrierschein. Falls erforderlich werden die Messflächen gemäß DIN 876 oder nach Ihren ganz persönlichen Anforderungen nachgearbeitet.

**Ihre Vorteile:**

- Sie sparen hohe Verpackungs- und Transportkosten
- Es besteht kein Risiko der Beschädigung auf dem Transportweg
- Die Ausfallzeit Ihrer Messplatte ist minimal

Weitere Informationen erhalten Sie unter:

[www.ultra-germany.com](http://www.ultra-germany.com) > Produkte > Service > Prüfmittelüberwachung

**Sonderprüfvorrichtungen auf Hartgesteinbasis:**

Wir liefern jede Art von Maschinenkomponenten sowie Sonderprüfvorrichtungen für Ihren speziellen Anwendungsfall – auf Wunsch auch Konzeption und Konstruktion, gegen Berechnung. Beispiele bereits realisierter Sonderlösungen finden Sie auf Seite 7.6.

**ULTRA granite measuring plates:**

We measure your measuring plates directly on your site and issue a calibration certificate. If necessary, the measuring surfaces are re-worked according to DIN 876, or according to your personalised requirements.

**Your advantages:**

- You save the high packaging and transport costs
- No risk of damages in transit
- Minimum downtime for your measuring plate

More information can be had at:

[www.ultra-germany.com](http://www.ultra-germany.com) > Products > Service > Calibration

**Special test units on granite base:**

We supply all types of machine components and special test units for your special case of application – if need be conception and design are also undertaken for a fee. You may find examples of already implemented special solutions on page 7.6.

## ULTRA Flachlineale und Montagelineale aus Aluminium

Aluminiumlineale sind leicht und handlich; ca. 2/3 Gewichtersparnis gegenüber Stahllinealen.  
Eine Hart-Coat Beschichtung sorgt für hohe Verschleißfestigkeit und Korrosionsbeständigkeit.

Schichteigenschaften:

- Schichtstärke ca. 50µ
- Härte 500 – 550HV
- hohe elektrische Isolationswirkung /  $4 \cdot 10^{15} \Omega \text{ mm}^2 / \text{m}$
- geringe Wärmeleitfähigkeit
- gutes Gleitverhalten

### Ebenheitstoleranzen für Lineale nach DIN 874

Die Berechnung erfolgt nach den in der Tabelle angegebenen Formeln (die Toleranzen sind gerundet).

Die nach DIN angegebenen Toleranzen haben nur Gültigkeit, wenn eine Lagerung der Lineale an den optimalen Auflagepunkten gemäß Skizze erfolgt. Für die Parallelität der Messflächen zueinander gelten die doppelten Werte.

Länge / Length a = mm	ⓄⓄ 00 (1 + a/150)µ	ⓄⓄ 0 (2 + a/100)µ	ⓄⓄ 1 (4 + a/60)µ	ⓄⓄ 2 (8 + a/40)µ
300	2	5	-	-
500	4	7	12	21
750	6	9,5	17	27
1000	8	12	21	33
1500	11	17	29	46
2000	14	22	37	58
2500	-	27	46	71
3000	-	32	54	83
4000	-	42	71	108
5000	-	52	87	133
6000	-	62	104	158

## ULTRA aluminium straightedges, flat and assembling

Aluminium straightedges are light and handy; approx. 2/3rd of the weight is saved in comparison to steel straightedges.  
A hard coat provides for high wear and corrosion resistances.

Coat properties:

- Coat thickness approx. 50µ
- Hardness 500 – 550HV
- High electrical insulation /  $4 \cdot 10^{15} \Omega \text{ mm}^2 / \text{m}$
- Minor thermal conductivity
- Good sliding property

### Flatness tolerances for straightedges according to DIN 874

The calculation is done according to the formulas given in the table; the tolerances are rounded off.

The tolerances specified in the table are valid only if the suspension of the straightedges on its bearing points is done according to the drawing. Double values apply for the parallelism of the measuring surfaces to one another.

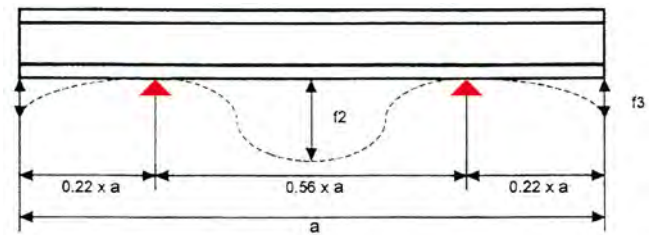

▲ Optimale Auflagepunkte / Bearing points

### Teilungsgenauigkeit und Geradheit von Maßstäben nach DIN 866 Form A und B

Die Geradheit bezieht sich auf die untere Messfläche.

- Form A** – Maßstab beidseitig mit 10mm Schutzenden  
**Form B** – Maßstab links mit 0-Strich beginnend, rechts mit 10mm Schutzende

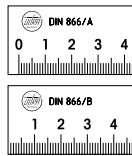

### Scale accuracy and straightness of rules according to DIN 866, form A and B

The straightness refers to the lower measuring surface.

- Form A** – 10 mm protective ends on both sides of rule  
**Form B** – Rule begins on the left with 0 point; right with 10 mm protective end.

Länge / Length a = mm	Form A		Form B	
	Geradheit Straightness µ	Teilungsgenauigkeit Scale accuracy µ	Geradheit Straightness µ	Teilungsgenauigkeit Scale accuracy µ
500	35	30	70	75
1000	60	40	120	100
1500	85	50	170	125
2000	110	60	220	150
3000	160	80	320	200

### Längentoleranzen

Längentoleranzen von Gliedermaßstäben, Bandmaßen und Rollmaßen nach EG Genauigkeitsklassen.

Länge / Length m	0,5	1	2	3	5	10	15	20	25	30	50
EG I / mm	0,2	0,2	0,3	0,4	0,6	1,1	1,6	2,1	2,6	3,1	5,1
EG II / mm	0,5	0,5	0,7	0,9	1,3	2,3	3,3	4,3	5,3	6,3	10,3
EG III / mm	1	1	1,4	1,8	2,6	4,6	6,6	8,6	10,6	12,6	20,6

### Length tolerances

Length tolerances of folding rules, measuring tapes and roller tapes, are as per EC accuracy classes.

### Sonderskalen und Nonien

Wir liefern jede Art von Sonderskalen und Zifferblätter mit hochgenauer Laserteilung aus Stahl, rostfreiem Stahl, Messing, Aluminium etc. Zur Angebotserstellung bitten wir um Ihre Anfrage mit Zeichnungsunterlagen.

### Special scales and verniers

We supply all types of special scales and dials with highly accurate laser scale, made of steel, stainless steel, brass, aluminium, etc. For the preparation of a quotation, we request you to send us your drawings.



**Winkel nach DIN 875**

Diese Norm gilt für Flachwinkel (Form A), Anschlagwinkel (Form B) und Haarwinkel (Form C) aus Stahl mit einem Winkel von 90° und einer Schenkellänge bis 1500mm.

**Winkeltoleranzen**

Die Berechnung erfolgt nach den in der Tabelle angegebenen Formeln (die Toleranzen sind gerundet). Für die Parallelität der Messflächen zueinander gelten die gleichen Werte.

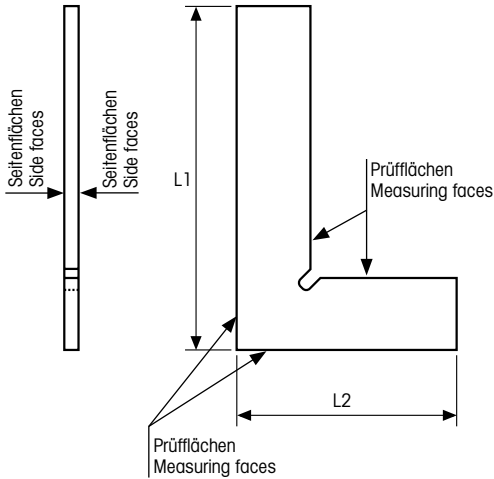

**Squares according to DIN 875**

This standard is valid for flat squares (design A), back squares (design B) and bevel edge squares (design C), of steel with a 90° angle and a leg length up to 1500 mm.

**Angle tolerances**

The calculation is done according to the formulas given in the table; the tolerances are rounded off. Equal values are applicable for the parallelism of the measuring surfaces to one another.

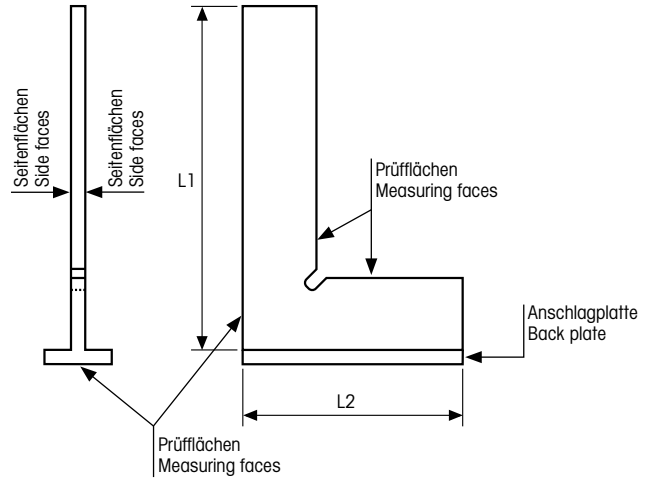

L = Schenkellänge L1 oder L2

L = Leg lengths L1 or L2

Länge / Length L = mm	00 (2 + L/100)µ	0 (5 + L/50)µ	1 (10 + L/20)µ	2 (20 + L/10)µ
50	3	-	-	-
75	3	7	14	28
100	3	7	15	30
150	4	8	18	35
200	4	9	20	40
250	5	10	23	45
300	5	11	25	50
400	-	13	30	60
500	-	15	35	70
600	-	17	40	80
750	-	20	43	85
1000	-	25	60	120
1500	-	35	85	170

**Ebenheitstoleranzen**

Die Ebenheit der Prüfflächen bzw. Geradheit der Haarmesskanten wird mit folgenden Formeln errechnet:

L = Schenkellänge L1 oder L2

00	Formel
00	(2 + L/250)µ
0	(2 + L/100)µ
1	(4 + L/50)µ
2	(8 + L/25)µ

**Flatness tolerances**

The flatness of the test surfaces and/or straightness of the bevelled edge are calculated using the following formulas:

L = Leg lengths L1 or L2

00	Formula
00	(2 + L/250)µ
0	(2 + L/100)µ
1	(4 + L/50)µ
2	(8 + L/25)µ

**Kalibrierung:**

Für alle Winkel können Werkskalibrierscheine erstellt werden. Bitte beachten Sie hierzu unsere Nettopreisliste für die Erstellung von Prüfberichten.

Weitere Informationen erhalten Sie unter:  
[www.ultra-germany.com](http://www.ultra-germany.com) > Produkte > Service > Prüfmittelüberwachung

**Calibration:**

Works calibration certificates are issued for all squares. Please check our net price list for the issue of inspection reports.

More information can be had at:  
[www.ultra-germany.com](http://www.ultra-germany.com) > Products > Service > Calibration

## Messschieber nach DIN 862

Taschenmessschieber mit Tiefenmaß eignen sich zur 4-fach Messung gemäß unten stehenden Anwendungsbeispielen. Werkstattmessschieber haben abgesetzte und gerundete Messschnabelenden zur Innenmessung. Die Messerspitzen werden zur Messung in Nuten und Einstichen verwendet (siehe Abb.).

### Taschenmessschieber / Pocket calipers:

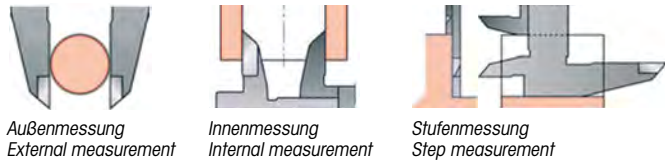

Außenmessung  
External measurement

Innenmessung  
Internal measurement

Stufenmessung  
Step measurement

Tiefenmessung  
Depth measurement

## Vernier calipers according to DIN 862

Pocket calipers with depth gauge are suitable for 4-way measurement, according to below mentioned examples of use. Workshop vernier calipers have split and rounded jaw ends (nibs) for internal measurement, the knife points are used for measuring in slots and grooves (see fig.).

### Werkstattmessschieber / Workshop calipers:

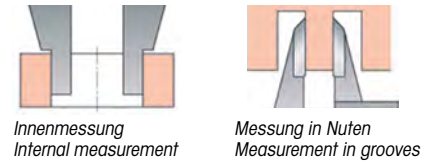

Innenmessung  
Internal measurement

Messung in Nuten  
Measurement in grooves

### Fehlergrenzen nach DIN 862

Die nach DIN festgelegten Fehlergrenzen (G) gelten für Messungen ohne Richtungswechsel der Messkraft. Bei Messungen mit Richtungswechsel und für Messungen mit dem Tiefenmaß erhöhen sich die Werte für Digitalmessschieber um 20µ, für Messschieber mit Rundskala oder Nonius gilt folgende Formel:  $G = (20 + l/10)\mu > 50\mu$

Werte A = Nonius 1/10mm oder 1/20mm :  $G = (20 + l/10)\mu$   
 Werte B = Nonius 1/50mm :  $G = (22 + l/50)\mu$   
 Werte C = Ablesung digital 0,01mm :  $G = (22 + l/50)\mu$

l [mm]	A (G)µ	B (G)µ	C (G)µ
50	50	20	20
100	50	30	30
200	50	30	30
300	50	30	30
400	60	30	30
500	70	30	30

### Error limits according to DIN 862

The error limits (G) specified according to DIN is applicable for measurements without change of direction of the measuring force. For measurements with change of direction and for measurements with the depth gauge, the values for digital calipers increase by 20µ; for calipers with round scale or vernier, the following formula is applicable:  $G = (20 + l/10)\mu > 50\mu$

Values A = Vernier 1/10mm or 1/20mm :  $G = (20 + l/10)\mu$   
 Values B = Vernier 1/50mm :  $G = (22 + l/50)\mu$   
 Values C = Digital reading 0.01mm :  $G = (22 + l/50)\mu$

l [mm]	A (G)µ	B (G)µ	C (G)µ
600	80	30	30
700	90	40	40
800	100	40	40
900	110	40	40
1000	120	40	40
1200	140	50	-

### Übersicht der IP Schutzarten nach DIN EN 60529 (angenähert)

(IP = International Protection)

Beispiel: IP67 = Staubdicht und gegen zeitweiliges Untertauchen in Wasser geschützt!

Schutz gegen Fremdkörper und Staub (1. Ziffer)		Schutz gegen Nässe (2. Ziffer)	
IP 1x	Fremdkörper >50mm	IP x1	Tropfwasser senkrecht
IP 2x	Fremdkörper >12,5mm	IP x2	Tropfwasser bis 15° Neigung
IP 3x	Fremdkörper >2,5mm	IP x3	Sprühwasser bis 60° Neigung
IP 4x	Fremdkörper >1,0mm	IP x4	Spritzwasser
IP 5x	Staubgeschützt	IP x5	Strahlwasser
IP 6x	Staubdicht	IP x6	starkes Strahlwasser
		IP x7	Zeitweiliges Untertauchen
		IP x8	Dauerndes Untertauchen

### Overview of the IP class according to DIN EN 60529 (approximated)

(IP = International Protection)

Example: IP 67 = dust-proof and protected from sporadic immersion in water!

Protection against impurities and dust (1 numeral)		Protection against moisture (2 numeral)	
IP 1x	Impurity > 50 mm	IP x1	Dripping water vertical
IP 2x	Impurity >12.5 mm	IP x2	Dripping water up to 15° incline
IP 3x	Impurity >2.5 mm	IP x3	Spray water up to 60° incline
IP 4x	Impurity >1.0 mm	IP x4	Spray water
IP 5x	Protected from dust	IP x5	Hose water
IP 6x	Dust-proof	IP x6	Strong hose water
		IP x7	Sporadic immersion
		IP x8	Continuous immersion

### Noniusablesung

Je nach Ausführung der Messschieber kommen folgende Varianten zum Einsatz:

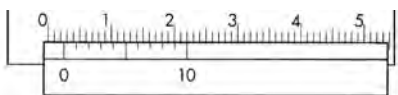

Nonius / Vernier - 1/10mm (0,1mm)

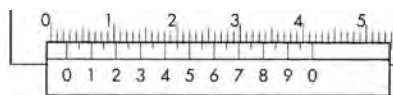

Nonius / Vernier - 1/20mm (0,05mm)



Nonius / Vernier - 1/50mm (0,02mm)

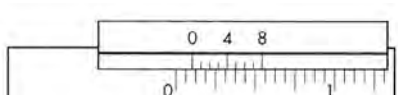

Nonius / Vernier - 1/128"

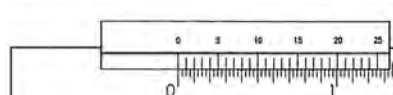

Nonius / Vernier - 1/1000"

### Vernier reading

According to the model of the calipers, the following versions are used:



**Messschrauben nach DIN 863**

Messschrauben sind nach DIN 863 Teil 1 – 4 genormt.  
 Teil 1: Bügelmessschrauben, Normalausführung  
 Teil 2: Einbaumessschrauben, Tiefenmessschrauben  
 Teil 3: Bügelmessschrauben, Sonderausführungen  
 Teil 4: Innenmessschrauben

**Fehlergrenzen für Bügelmessschrauben nach DIN 863 Teil 1:**

**Werte A** = Abweichungsspanne der Anzeige  
**Werte B** = Parallelität der Messflächen  
**Werte C** = Aufbiegung des Bügels

Die in der Tabelle angegebenen Werte setzen eine Messkraft von 5 – 10N voraus. Die Toleranzen unserer Messschrauben sind in der Regel geringer als die nach DIN zulässigen Werte.

mm	A μ	B μ	C μ
0 – 25	4	2	2
25 – 50	4	2	2
50 – 75	5	3	3
75 – 100	5	3	3
100 – 125	6	3	4
125 – 150	6	3	5
150 – 175	7	4	6
175 – 200	7	4	6
200 – 225	8	4	7
225 – 250	8	4	8

**Micrometers according to DIN 863**

Micrometers are standardised Part 1 – 4 according to DIN 863.  
 Part 1: External micrometers, normal model  
 Part 2: Micrometer heads, depth micrometers  
 Part 3: External micrometers, special models  
 Part 4: Internal micrometers

**Error limits for external micrometers according to DIN 863 Part 1:**

**Values A** = Deviation range of the indication  
**Values B** = Parallelism of the measuring surfaces  
**Values C** = Bending up of the frame

The values specified in the table presupposes a measuring force of 5 – 10N. The tolerances of our micrometers are usually lower than the DIN permissible values.

mm	A μ	B μ	C μ
250 – 275	9	5	9
275 – 300	9	5	9
300 – 325	10	5	10
325 – 350	10	5	10
350 – 375	11	6	11
375 – 400	11	6	12
400 – 425	12	6	12
425 – 450	12	6	13
450 – 475	13	7	14
475 – 500	13	7	15

**Ablesung Skalentrommel**

Je nach Ausführung der Mikrometer kommen folgende Varianten zum Einsatz:



*Ablesung 0,01mm, Spindelsteigung 0,5mm  
 (50 Teilstriche auf der Trommel)*

*Reading 0.01 mm, spindle pitch 0.5 mm  
 (50 graduation marks on the drum)*



*Ablesung 0,01mm, Spindelsteigung 1,0mm  
 (100 Teilstriche auf der Trommel,  
 Ablesung ohne Addition)*

*Reading 0.01 mm, spindle pitch 1.0 mm  
 (100 graduation marks on the drum,  
 reading without addition)*



*Ablesung 0,005mm, Spindelsteigung 0,5mm  
 (100 Teilstriche auf der Trommel)*

*Reading 0.005 mm, spindle pitch 0.5 mm  
 (100 graduation marks on the drum)*

**Kalibrierung:**

Für alle Messschrauben können, Werkskalibrierscheine erstellt werden. Eine DAkkS Kalibrierung durch ein akkreditiertes Labor ist für viele Typen ebenfalls möglich. Bitte beachten Sie hierzu unsere Nettopreisliste für die Erstellung von Prüfberichten.

Weitere Informationen erhalten Sie unter:

[www.ultra-germany.com](http://www.ultra-germany.com) > **Produkte** > **Service** > **Prüfmittelüberwachung**

**Messschrauben mit Sondermessflächen und Sonderanfertigungen:**

Wir liefern Messschrauben mit besonderen Messflächenformen (siehe Seite 13.18) sowie jede Art von feinmechanischen Bauteilen und Spindelantrieben nach Ihren Zeichnungen – auf Wunsch auch Konzeption und Konstruktion, gegen Berechnung.

Zur Angebotserstellung bitten wir um Ihre Anfrage mit Zeichnungsunterlagen.

**Beispiele für kundenspezifische Sonderlösungen:**



**Calibration:**

Works calibration certificates are issued for all micrometers. A DAkkS calibration certificate from an accredited laboratory is likewise possible for many types. Please check our net price list for the issue of inspection reports.

More information can be had at:

[www.ultra-germany.com](http://www.ultra-germany.com) > **Products** > **Service** > **Calibration**

**Micrometers with special measuring faces and special devices:**

We supply micrometers with special measuring face shapes (see page 13.18), and all types of fine mechanical devices and spindle drives according to your drawings – on request also undertake conception and design at a cost.

For the preparation of a quotation, please send us your inquiries with drawings.

**Examples of customer-specific special solutions:**

## Härteprüfung, Begriffserklärungen

### Härteprüfung nach Brinell HB / DIN EN ISO 6506

Eine gehärtete Stahl- oder Hartmetallkugel (HBS, HBW) wird in die Oberfläche einer Probe eingedrückt. Der Härtewert wird aus dem Verhältnis der Prüfkraft zum Eindruckdurchmesser bestimmt.

### Härteprüfung nach Vickers HV / DIN EN ISO 6507

Ein Diamant-Eindringkörper in Form einer vierseitigen Pyramide wird in die Oberfläche einer Probe eingedrückt. Der Härtewert wird aus dem Verhältnis der Prüfkraft zu den Abmessungen der Eindruckdiagonalen bestimmt.

### Härteprüfung nach Rockwell HRC, HRA, HRB, HRF / DIN EN ISO 6508

Der Eindringkörper (Diamantkegel oder Hartmetallkugel) wird mit einer Prüfvorlast, die den Anfangspunkt der Eindringtiefe bestimmt und der Prüflast in die Probe gedrückt. Nach Rücknahme der Prüflast wird die Eindringtiefe unter Prüfvorlast gemessen. Der Härtewert wird aus der Differenz der Eindringtiefe von Prüflast und Prüfvorlast bestimmt.

### Dynamische Härteprüfung nach LEEB HL

Bei der Prüfung wird ein Schlagkörper mit einer Hartmetall-Prüfkugel durch Federkraft gegen die Prüffläche geschlagen und prallt dann wieder zurück. Die Messwerte aus Aufprall- und Rückprallgeschwindigkeit werden im Anzeigergerät zum Härtewert L verarbeitet.

### Schlaghärteprüfer System POLDI (nicht für Härte < 55HRC)

Mit einem Hammer (1000 g) wird bei eingelegtem Härtevergleichsstab (die Zugfestigkeit ist auf dem Vergleichsstab markiert) auf den Tester geschlagen. Durch die im Tester befindliche Stahlkugel wird ein Eindruck am Vergleichsstab und ein Eindruck am Werkstück erzeugt. Der Härtewert wird in Brinell über die Auswertung beider Eindruckdurchmesser anhand einer Tabelle bestimmt.

### Rückprallhärteprüfer System SKLEROGRAF

Die Fallstange schlägt auf die Werkstückoberfläche auf und prallt zurück. Bei der größten Rückprallhöhe wird die Fallstange durch eine eingebaute Fangvorrichtung festgehalten und der Wert an einer Skala abgelesen. Der Härtewert wird durch eine Vergleichstabelle bestimmt.

### Shore A und Shore D (DIN 53505, ISO 7619-1, DIN EN ISO 868)

(Prüfung von Gummi, Kunststoffen und Thermoplasten)  
Ein Kegelstumpf aus Stahl dringt mit einer definierten Federkraft in die Probe ein. Die Shore-Härte wird direkt an der Skala abgelesen. Werkstoffe mit einer Shore A-Härte >80 werden nach Shore D und Werkstoffe mit einer Shore D-Härte <30 nach Shore A geprüft.

### Härtevergleichstabelle (Rm = N/mm<sup>2</sup>) HV/HB/HRC

Nach DIN 50150 ist ein Umrechnen von Härtewerten nicht gültig. Die Werte sind nur annähernd vergleichbar.

Rm	HV	HB	HRC	Rm	HV	HB	HRC	Rm	HV	HB	HRC	Rm	HV	HB	HRC
240	75	71	-	575	180	171	-	940	293	278	29	1680	514	488	50
255	80	76	-	595	185	176	-	970	302	287	30	1730	527	501	51
270	85	81	-	610	190	181	-	995	310	295	31	1790	544	517	52
285	90	86	-	625	195	185	-	1020	317	301	32	1845	560	532	53
305	95	90	-	640	200	190	-	1050	327	311	33	1910	578	549	54
320	100	95	-	660	205	195	-	1080	336	319	34	1980	596	567	55
335	105	100	-	675	210	199	-	1110	345	328	35	2050	615	584	56
350	110	105	-	690	215	204	-	1140	355	337	36	2140	639	607	57
370	115	109	-	705	220	209	-	1170	364	346	37	-	655	622	58
385	120	114	-	720	225	214	-	1200	373	354	38	-	675	-	59
400	125	119	-	740	230	219	-	1230	382	363	39	-	698	-	60
415	130	124	-	755	235	223	-	1260	392	372	40	-	720	-	61
430	135	128	-	770	240	228	-	1300	403	383	41	-	745	-	62
450	140	133	-	785	245	233	-	1330	413	393	42	-	773	-	63
465	145	138	-	800	250	238	22	1360	423	402	43	-	800	-	64
480	150	143	-	820	255	242	23	1400	434	413	44	-	829	-	65
495	155	147	-	835	260	247	24	1440	446	424	45	-	864	-	66
510	160	152	-	860	268	255	25	1480	458	435	46	-	900	-	67
530	165	157	-	870	272	258	26	1530	473	449	47	-	940	-	68
545	170	162	-	900	280	266	27	1570	484	460	48	-	-	-	-
560	175	166	-	920	287	273	28	1620	497	472	49	-	-	-	-

## Hardness testing, definitions

### Hardness testing according to Brinell HB / DIN EN ISO 6506

A hardened steel or tungsten carbide ball (HBS, HBW) is pressed into the surface of a specimen. The hardness value is determined by the ratio of the test force to the diameter of the impression.

### Hardness testing according to Vickers HV / DIN EN ISO 6507

A diamond indenter in the shape of a four-sided pyramid is pressed into the surface of a specimen. The hardness value is determined by the ratio of the test force to the measurements of the impression diagonal.

### Hardness testing according to Rockwell HRC, HRA, HRB, HRF / DIN EN ISO 6508

The diamond indenter (diamond taper or tungsten carbide ball) is pressed into the specimen with a pre-load, which determines the initial point of the indent depth and the test load of the specimen. After retraction of the test load, the indent depth is measured under pre-load. The hardness value is determined by the difference in the indent depths of the test load and the pre-load.

### Dynamic hardness testing according to LEEB HL

When the test is carried out, an impact body with a tungsten carbide test ball is impelled by spring force against a test surface from which it rebounds. These velocities are processed and displayed as the hardness value L on the indicating device.

### Impact hardness tester system POLDI (not suitable for hardness < 55HRC)

A hammer (1000 g) is impacted on the tester with inlaid hardness comparison bar (the tensile strength is marked on the comparison bar). An impression is made on the comparison bar and another on the workpiece with a steel ball in the tester. The hardness value in Brinell is determined by the evaluation of the diameters of both impressions by means of a table.

### Scroscope system SKLEROGRAF

The drop bar impacts on the surface of the workpiece and rebounds back. The largest rebound height is recorded by the drop bar by an inbuilt gripping device and the value is read on a scale. The hardness value is determined by a comparison table.

### Shore A and Shore D (DIN 53505, ISO 7619-1, DIN EN ISO 868)

(Testing of rubber, plastics and thermoplastics)  
A steel taper pin is indented on the specimen with a defined spring force. The Shore hardness is directly read on the scale. Materials with a Shore A hardness >80 are tested according to Shore D, and materials with a Shore D hardness <30, according to Shore A.

### Hardness comparison table (Rm = N/mm<sup>2</sup>) HV/HB/HRC

According to DIN 50150, a conversion of hardness values is invalid. The comparison of the values is only approximate.

## Linsen, Begriffserklärungen

Grundsätzlich wird zwischen sphärischen und asphärischen Linsen unterschieden.



**Sphärische Linsen** haben in Ihrer Krümmung einen einheitlichen Radius, dies führt zu leichten Verzerrungen der Abbildung im Randbereich.

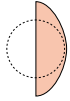

**Asphärische Linsen** haben unterschiedliche Krümmungen (keinen einheitlichen Radius) und deshalb eine deutlich bessere Abbildungsqualität im Randbereich.

Die Flächen einer Linse können konvex, eben (plan) oder konkav sein. In der Regel werden sphärische Linsen mit folgenden unterschiedlichen Linsengeometrien verwendet:



### Plankonvexe Form

Lichtsammelnde Wirkung, eine Fläche ist plan die andere ist nach außen gewölbt.

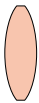

### Bikonvexe Form

Bessere Abbildungsqualität und höhere Vergrößerung als plankonvexe Linsen. Beide Flächen sind nach außen gewölbt.

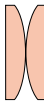

### Aplanatische Form

Randscharfe und verzerrungsfreie Abbildung. Zwei plankonvexe Linsen sind mit den gewölbten Flächen zueinander angeordnet.

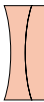

### Achromatische Form

Farbtechte Abbildungen. Unterdrückt störenden Farbsaum am Randbereich. Eine plankonvexe und eine bikonkave Linse sind hintereinander angeordnet.

## Dioptrienzahl, Vergrößerung

Die Dioptrienzahl (D) bezeichnet das Lichtbrechungsvermögen einer Linse. Der Vergrößerungsfaktor (V) errechnet sich nach folgender Formel:  $V = (D / 4) + 1$

## Internationale Maßeinheiten:

### Länge / Length

1 mm	0,03937 Zoll
1 cm	0,3937 Zoll
1 m	39,37 Zoll = 3,28083 Fuss = 1,0936 Yard
1 km	3280,83 Fuss = 1093,61 Yard = 0,62137 Meilen
1 Zoll	25,4 mm = 2,54 cm = 0,0254 m
1 Fuss	304,8 mm = 30,48 cm = 0,3048 m
1 Yard	0,9144 m
1 Meile	1,609 km

### Gewicht / Weight

1 g	0,035 Unzen = 15,432 Grans
1 kg	2,2046 Pounds = 35,274 Unzen(av)
1 to	2204,6 Pounds = 0,9842 Long Ton = 1,1023 Short Ton (av)
1 Gran	0,0648 g
1 Unze(av) oz.	28,35 g
1 Pound(av) lb.	0,4536 kg
1 Short Ton	0,907 to
1 Long Ton	1,016 to

## Lenses, definitions

Fundamentally, the spherical and aspherical lenses are distinguished.



**Spherical lenses** have a uniform radius in their curve, which lead to slight distortion of the image in the border area.

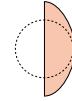

**Aspherical lenses** have differing curves (no uniform radius) and therefore have a clearly better image quality in the border area.

The surfaces of a lens can be convex, flat (plane) or concave. Generally, spherical lenses are used with the following differing lens geometries:

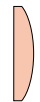

### Plano-convex shape

Light collecting effect, one surface is plane and the other is curved towards the outside.



### Biconvex shape

Better image quality and higher magnification than plano-convex lenses. Both surfaces are curved towards the outside.



### Aplanatic shape

Sharp edge and distortion-free image. Two plano-convex lenses are arranged together with the curved surfaces.

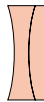

### Achromatic shape

Colour-fast images. Suppresses disturbing colour fringe in the border area. A plano-convex and a biconcave lens are arranged one after the other.

## Dioptre number, magnification

The dioptre number (D) specifies the refractory property of a lens. The magnification factor (V) is calculated according to the following formula:  $V = (D / 4) + 1$

## International measurements:

### Kraft / Force

1 N	0,101972 kp = 0,224809 lb.f
1 kp	9,80665 N = 2,204623 lb.f
1 lb.f	4,448222 N = 0,453592 kp

### Geschwindigkeit / Speed

1 km/h	0,62140 mph = 16,66670 m/min = 0,27780 m/sec
1 mph	1,60900 km/h = 26,82000 m/min = 0,44700 m/sec
1 ft/min	0,30480 m/min
1 m/min	3,28100 ft/min
1 ft/sec	0,30480 m/sec
1 m/sec	3,28100 ft/sec

### Temperatur / Temperature

0 °C	32 °F
37,7 °C	100 °F
100 °C	212 °F
0 °F	-17,778 °C
100 °F	37,778 °C

## 1/2/3...

µLevel Neigungsmesssystem..... 10.15  
3D-Taster ..... 6.42 – 6.44

## A

Abbrichtlineale..... 8.17  
Abrollböcke ..... 7.22, 7.26 – 7.27  
Abrollböcke pendelnd gelagert ..... 7.27  
Abrollböcke schwere Ausführung..... 7.26  
Abziehstein..... 1.8  
Achtkantwinkel 135° ..... 10.8  
Adapter für Feinzeiger..... 4.15  
Adapter für Messuhren ..... 4.15  
ALINOX Messsschieber .....  
..... 11.26, 11.30, 11.34 – 11.35  
Anbaumessschieber ..... 11.32  
Anreiß- und Abbrichtplatten..... 7.16  
Anreißfarben..... 7.16, 12.14  
Anreißlehre TALMETER ..... 9.10, 12.4  
Anreißmessschieber..... 12.7  
Anschlagwinkel..... 10.5 – 10.7  
Anschlagwinkel gehärtet ..... 10.5  
Anschlagwinkel stark/schwach.... 10.5, 10.7  
Anzeigende Rachenlehre ..... 2.21 – 2.24  
Anzeigende Rachenlehren CARBON ..... 2.24  
Aufspannwinkel mit Spannschlitz ..... 8.7  
Aufspannwinkel mit T-Nuten..... 8.8  
Aufspannwürfel mit T-Nuten ..... 8.9  
Außen- und Innentaster ..... 12.11

## B

Bandmaße für Außendurchmesser ..... 9.8  
Batterien für Digital-Messgeräte ..... 11.44  
Beleuchtungseinheit Standlupen..... 15.13  
Beleuchtungseinheit Taschenmikroskope .....  
..... 15.14  
Biegsame Maßstäbe..... 9.9  
Bluetooth-Dongel ..... 11.41  
Bohrungslehren ..... 9.17  
Bohrungslehren Satz ..... 9.19  
Bohrungsmessdorne..... 6.16  
Bowers Innenmessschrauben 13.40 – 13.46  
Bügelmessschrauben..... 13.3 – 13.30  
Bügelmessschrauben Amboss verschiebbar .....  
..... 13.7, 13.11  
Bügelmessschrauben eckiger Bügel .....  
..... 13.8, 13.30  
Bügelmessschrauben Gewindemessung .....  
..... 13.15 – 13.16  
Bügelmessschrauben Keilwellenmessung .....  
..... 13.26  
Bügelmessschrauben mit Feinzeiger .....  
..... 13.5 – 13.6  
Bügelmessschrauben mit Messuhr.....  
..... 13.6 – 13.7  
Bügelmessschrauben mit Zählwerk ..... 13.3  
Bügelmessschrauben Prismenamboss 13.24  
Bügelmessschrauben Sondermessflächen .....  
..... 13.18, 13.25 – 13.29  
Bügelmessschrauben Verzahnungsmessung .....  
..... 13.22 – 13.22  
Bügelmessschrauben Zahnweitenmessung...  
..... 13.19 – 13.21

## C

Clinometer ..... 10.16  
Convertor ..... 2.7

## D

Datenübertragung, kabellos..... 11.43  
Datenübertragungskabel ..... 11.41  
Dickenmessgeräte ..... 6.9 – 6.12  
Dickenmessgeräte für dünne Folien ..... 6.12  
Dickenmessgeräte große Bügel ..... 6.11  
Dickenmessgeräte mit Messrollen ..... 6.12  
Dickenmessgeräte Rohrwandmessung... 6.9  
Digital Messuhren ..... 4.3 – 4.6  
Digital Schnelltaster Dreipunkt-Innenmessung .....  
..... 6.3  
Digital-Anbaumessschieber ..... 11.32  
Digital-Bügelmessschrauben.....  
..... 13.3 – 13.4, 13.16, 13.21, 13.25  
Digital-Dickenmessgeräte ... 6.9 – 6.10, 6.12  
Digital-Einbaumessschrauben .....  
..... 13.5, 13.25, 13.36  
Digital-Fühlhebelmessgeräte ..... 4.18  
Digital-Gradmesser ..... 10.13  
Digital-Handhängewaagen..... 15.3 – 15.4  
Digital-Handtachometer ..... 14.2  
Digital-Höhenmessgeräte..... 12.2 – 12.3  
Digital-Hygro- und Thermometer ..... 14.10  
Digital-Innenfeinmessdorne ..... 6.14  
Digital-Innenmessgeräte ..... 13.37  
Digital-Innenmessschrauben Dreipunkt .....  
..... 13.40 – 13.45, 13.47  
Digital-Innenmessschrauben Messschnäbeln .....  
..... 13.33 – 13.34  
Digital-Innenmessschrauben Verzahnungs-  
messung..... 13.23  
Digital-Innenmessschrauben Zweipunkt .....  
..... 13.40 – 13.45, 13.47  
Digital-Kraftmessgeräte ..... 15.6 – 15.7  
Digital-Kranwaagen ..... 15.4 – 15.5  
Digital-Kurbelwellen-Prüfgeräte ..... 6.39  
Digital-Längenmaßstab CARBON 11.31, 15.8  
Digital-Messschieber ..... 11.3 – 11.9,  
..... 11.13, 11.16 – 11.19, 11.21 – 11.27  
Digital-Messschieber (3 / 5) schneidig. 11.14  
Digital-Messschieber ALINOX ..... 11.26  
Digital-Messschieber CARBON 11.21 – 11.23  
Digital-Messschieber Innennuten .....  
..... 11.16 – 11.17  
Digital-Messschieber IP67 ..... 11.24  
Digital-Messschieber lange Schnäbel... 11.25  
Digital-Messschrauben .....  
..... 13.3 – 13.4, 13.16, 13.21, 13.23, 13.25  
Digital-Messuhren mit Skalanzeige ..... 4.5  
Digital-Neigungsmesser ..... 10.19  
Digital-Plattformwaagen ..... 15.3  
Digital-Präzisionsthermometer ... 14.7 – 14.8  
Digital-Präzisionswaagen..... 15.2  
Digital-Rauheitsmessgerät ..... 14.13  
Digital-Schichtdickenmessgeräte .....  
..... 14.15 – 14.16  
Digital-Schnellmessgerät für Spaltmessung...  
..... 9.18  
Digital-Schnellmessgerät für Versatzmessung .....  
..... 9.18

Digital-Schnellfaster Außenmessung.....  
..... 6.5, 6.7  
Digital-Schnellfaster Innenmessung .....  
..... 6.2 – 6.3, 6.7  
Digital-Sekundenthermometer ..... 14.8  
Digital-Stoppuhren..... 14.12  
Digital-Taschenmessschieber ..... 11.3 – 11.8  
Digital-Taschenmessschieber Sondermess-  
flächen..... 11.7 – 11.8  
Digital-Tiefenmessgeräte..... 6.13  
Digital-Tiefenmessschieber.....  
..... 11.5, 11.33 – 11.38  
Digital-Tiefenmessschieber ALINOX ..... 11.34  
Digital-Tiefenmessschieber CARBON ... 11.33  
Digital-Universalmessschieber 11.16 – 11.19  
Digital-Universalmessschieber ALINOX . 11.26  
Digital-Universalmessschieber CARBON .....  
..... 11.16, 11.18 – 11.19  
Digital-Vergleichsmessgeräte ..... 6.28, 6.31,  
..... 6.34 – 6.35, 6.38  
Digital-Voreinstellgeräte ..... 6.21 – 6.23  
Digital-Waagen ..... 15.2 – 15.5  
Digital-Wanddickenmessgeräte ..... 14.15  
Digital-Wasserwaagen ..... 10.21  
Digital-Werkstattmessschieber.....  
..... 11.21 – 11.23, 11.26 – 11.27  
Digital-Winkelmesser ..... 10.11  
Digitale Shore Härteprüfgeräte ..... 14.13  
DIN Schieber ..... 2.7  
Dosenlibellen und Präzisionslibellen ..... 10.22  
Drehstahllehren..... 9.21  
DUPLEX Lapp- und Kontrollplatten ..... 7.15  
Düsenlehre..... 9.16  
Dynamometer..... 15.8

## E

Einbaumessschrauben .....  
..... 13.5, 13.25, 13.36 – 13.37  
Einstellgerät für Vergleichsmessgeräte.....  
..... 1.11, 6.20  
Einstellmaße für Messschrauben..... 13.14  
Einstellringe aus Hartmetall ..... 2.18  
Einstellringe aus Keramik ..... 2.18  
Einstellringe DIN 2250-C..... 2.17  
Einstellringsatz aus Stahl..... 1.4  
Einzelendmaße aus Hartmetall..... 1.6  
Einzelendmaße aus Keramik ..... 1.7  
Einzelendmaße aus Stahl..... 1.5  
Einzelstützböcke für Messplatten..... 7.14  
Endmaßhalter ..... 1.9  
Endmaßpflegekasten-Satz ..... 1.8  
Endmaßsätze aus Hartmetall..... 1.6  
Endmaßsätze aus Keramik ..... 1.7  
Endmaßsätze aus Stahl ..... 1.3, 1.4  
Endmaßverbinder..... 1.5  
Endmaßzubehör-Sätze..... 1.9  
Ersatztaster für 3D-Taster ..... 6.42 – 6.43

## F

Fadenzähler..... 15.10 – 15.11  
Fasenslängenmessgeräte ..... 6.27  
Fasensmessgerät ..... 9.15  
Federlehren Zehntelmaße..... 9.22  
Federspitzzirkel ..... 12.10  
Federwaagen KONTAKTOR ..... 15.7

Federwaagen zylindrische Dynamometer .....	15.8
Federzirkel .....	12.10
Feineinstellung für Messstative .....	5.5
Feinmessstische Hartgestein .....	5.9
Feinmessstische Keramik .....	5.8
Feinmessstische Stahl .....	5.10
Feinzeiger MYCRO .....	4.7
Feinzeiger MYTAST .....	4.7
Feinzeiger-Messschrauben .. 2.23, 13.5, 13.6	
Feinzeiger-Rachenlehren .....	2.21, 2.24
Filetor .....	2.7
FISSO Messstative .....	5.3
Flachlineale aus Aluminium .....	9.4
Flachlineale aus Stahl .....	9.5
Flachwinkel .....	10.5 – 10.7
Flanschenwinkel .....	10.9
Fräseinstellehre .....	12.8
Fühlerlehrenband .....	9.13
Fühlerlehrenband mit Wandhalter .....	9.13
Fühlerlehrensätze .....	9.12
Fühlhebel für Messuhren .....	4.13
Fühlhebelmessgeräte .....	4.18 – 4.19
Funk-Datenübertragung .....	11.43
<b>G</b>	
Gehrungswinkel 135° .....	10.8
Gewindeeinsätze für Messmittel .....	7.13
Gewindeflankeneinsätze 2.25, 13.15 – 13.17	
Gewindeflankeneinsätze f. Rachenlehren	
.....	2.25
Gewindelehren Feingewinde ISO 1502	
(DIN 13) .....	3.5
Gewindelehren Hartmetall ISO 1502	
(DIN 13) .....	3.4
Gewindelehren NPT .....	3.4
Gewindelehren Regelgewinde ISO 1502	
(DIN 13) .....	3.3
Gewindelehren Trapezgewinde DIN 103 .....	3.7
Gewindelehren UNC, UNF .....	3.6
Gewindelehren UNEF .....	3.7
Gewindelehren Ww DIN ISO 228 .....	3.6
Gewindelehren Ww kegelig .....	3.5
Gewindemessdrähte .....	2.6, 13.18
Gewindeprüfdorne LEITECH .....	3.9
Gewindeschablonen .....	9.14
Gewindeschieber .....	2.7
Gewindestahllehren .....	9.21
Golitest Innenmessschrauben .....	13.47
Gradmesser .....	10.13
Gradwasserwaage .....	10.20
Granit-Messbänke .....	7.24
Granit-Messplatten .....	7.11 – 7.12
Grenz-Gewindelehndorne Keramik .....	3.8
Grenz-Gewinderollenrachenlehren .....	3.9
Grenzlehndorne Hartmetall .....	2.9
Grenzlehndorne Keramik .....	2.9
Grenzlehndorne, vollzylindrisch .....	2.7, 2.8
Grenzlochlehren, flach zylindrisch .....	2.10
Grenzrachenlehren .....	2.19 – 2.21
Grenzrachenlehren verstellbar .....	2.21
Grenzwellennutenlehren (Blockmaße) .....	3.10
Griffe für Prüfstifte .....	2.4
Griff lupen .....	15.15
Groß-Messuhren .....	4.12
Großanzeigen LED .....	11.42

Großfeld-Lupenleuchten .....	15.17
<b>H</b>	
Haarlineale aus Stahl .....	9.3
Haarwinkel gehärtet .....	10.4
Haarwinkel gehärtet stark/schwach .....	10.4
Haarwinkel verstellbar .....	10.3 – 10.4
Halbrunde Messschenkelpaare .....	1.10
Halter für Fühlhebelmessgeräte .....	4.20
Halter für QUICK CHECK .....	3.16, 6.25
Halter für Rachenlehren CARBON .....	2.25
Halterungen für CARBON Messgeräte .....	6.37
Hand- und Fußtaster .....	11.43
Hand-Kniehebelpresse .....	7.25
Hand-Stückzähler .....	14.3
Handhängewaagen .....	15.3 – 15.4
Handleucht lupen LED .....	15.16
Handstroboskop .....	14.3
Handtachometer .....	14.2
Handtachometer UNIVERSAL .....	14.3
Handtounenzähler .....	14.3
Hängewaagen, digital .....	15.3 – 15.4
Härteprüfer HARTIP .....	14.10 – 14.11
Hartgestein-Messbänke .....	7.24
Hartgestein-Messplatten .....	7.11 – 7.12
Hartgestein-Messstische .....	5.9
HARTIP Härteprüfer .....	14.10 – 14.11
Höhenmessgeräte .....	12.4 – 12.4
Höhenmikrometer mit Zählwerk .....	13.31
HSK Messgerät .....	2.15
Hubzähler .....	14.5
Hygrometer .....	14.10
<b>I</b>	
Infrarot Handthermometer .....	14.7
Innen- und Außen taster .....	12.9
Innen-Schnellmessgeräte Dreipunkt .....	13.42 – 13.43
Innen-Schnellmessgeräte Zweipunkt .....	13.42 – 13.43
Innenfasenmessgerät .....	6.27
Innenfeinmessdorne .....	6.14
Innenfeinmessgeräte .....	6.15, 6.17-6.19
Innenmessschrauben .....	13.22 – 13.23,
.....	13.33 – 13.36, 13.38 – 13.39
Innenmessschrauben Dreipunkt .....	13.40 – 13.48
Innenmessschrauben Gewindemessung 13.17	
Innenmessschrauben lange Messzapfen .....	13.36
Innenmessschrauben mit Messschnäbeln .....	13.33 – 13.34
Innenmessschrauben Verzahnungsmessung .....	13.22 – 13.23
Innenmessschrauben Zweipunkt .....	13.40 – 13.48
Isoliergriffe .....	1.8
<b>K</b>	
Kantentaster .....	6.44
Kastenwürfel mit Spannschlitz .....	8.9
Kegellehren für Futterflansch .....	2.11
Kegellehren für Morsekegel .....	2.10
Kegellehren für Steilkegel .....	2.11

Kegelprüfgeräte Sinusprinzip .....	7.19
Keilnaben- und Keilwellenlehren .....	3.12
Kerbverzahnungslehren .....	3.12
Klapplupen .....	15.11 – 15.12
Klein-Messuhren .....	4.6, 4.8
Kleinmessschieber .....	11.10
Knopfmaße Kleinmessschieber .....	9.22
Kombinations-Winkelmesser .....	10.12
KONTAKTOR Federwaagen .....	15.7
Kontroll- und Tuschieplatten .....	7.15
Kontrolllineale aus Stahl, gehärtet .....	9.4
Kopfbandlupen .....	15.10
Korrosions-Schutzöl .....	1.8
Kraftmessdosen Druckkraftmessung .....	15.5
Kraftmessgerät für Messschrauben .....	13.12
Kranwaagen .....	15.4 – 15.5
Kröplin Schnell taster .....	6.2 – 6.6
KT Hartmetall-Kugeleinsätze .....	3.14, 6.18
KT Innenfeinmessgeräte .....	3.14, 6.18
Kugellehren aus Hartmetall .....	1.12
Kurbelwellen-Prüfgeräte .....	6.39
Kurbelwellenprüfgeräte .....	7.2
<b>L</b>	
Lamellenblöcke .....	8.6
Läpp- und Kontrollplatten DUPLEX .....	7.15
LASER Mehrstellenmessvorrichtungen .....	7.5
LED Großanzeige .....	11.42
LED Ring-Lupenleuchte .....	15.16 – 15.17
Lehrenschaubstöcke mit Sinusfunktion .....	8.3
Lehrenschaubstöcke mit Gewindespindel .....	8.2, 8.3
Lehrenschaubstöcke mit Schnellverstellung .....	8.2
LEITECH Gewindeprüfdorne .....	3.9
Lesegläser .....	15.15
Lineale .....	8.17, 9.3 – 9.8
Lineale mit Facette .....	9.8
Lochlehren Millimeterlehren .....	9.17
Lösemittelspray für Anreißfarben .....	7.19, 12.14
Lupen .....	15.10 – 15.17
Lupenleuchten .....	15.16 – 15.17
<b>M</b>	
Magnet- Mess- und Spannprismen .....	8.12 – 8.13
Magnet-Halter .....	4.14, 5.5
Magnet-Messstativ .....	5.3 – 5.6
Magnettüße .....	5.5
Magnetspannplatte .....	8.5
Maßstäbe biegsam .....	9.9
Maßstäbe mit Facette .....	9.8
Maßstäbe mit Facette aus Stahl .....	9.7
Mehrstellenmessvorrichtung .....	7.5
Mess- und Anreißkamin mit Spannlöchern .....	8.10
Mess- und Kontrollplatten (Hartgestein) .....	7.11 – 7.12
Messbalken aus Naturhartgestein .....	8.18
Messbalken aus Spezialguss .....	8.17
Messbänke aus Spezialguss .....	7.20
Messbänke für Rundlaufprüfgeräte .....	7.24
Messbereich-Verlängerungen für TGU .....	6.28
Messdorne einzeln, aus Hartmetall .....	2.5
Messdorne einzeln, aus Spezialstahl .....	2.5

Messdorne einzeln, aus Keramik .....2.6  
 Messdornsätze aus Spezialstahl .....2.4  
 Messdrähte Gewindemessung..... 2.6, 13.18  
 Messeinsätze für Messuhren ..... 4.16 – 4.17  
 Messeinsätze für QUICK CHECK... 3.16, 6.25  
 Messeinsätze für Rachenlehren.....2.25  
 Messeinsätze für Taschenmessschieber 11.6  
 Messeinsätze für Tiefenmessschieber... 11.37  
 Messeinsätze für Vergleichsmessgeräte .....  
 ..... 6.36, 11.20  
 Messkeile ..... 9.17  
 Messkugeln einzeln ..... 1.12  
 Messkugeln im Halter ..... 13.22 – 13.23  
 Messkugelsätze aus Chromstahl..... 1.12  
 Messkugelsätze aus Hartmetall ..... 1.12  
 Messkugelsätze aus rostfreiem Stahl ... 1.12  
 Messlupe mit Skala..... 15.12  
 Messmittelhalter für Messschrauben ... 13.12  
 Messmodule für Wellenmesszentrum .....  
 ..... 7.3 – 7.4  
 Messplatten ..... 7.11 – 7.17  
 Messräder für Meterzähler ..... 14.6  
 Messsäule 90° ..... 8.11  
 Messschieber ..... 11.3 – 11.40  
 Messschieber (3 / 5) schneidig ..... 11.14  
 Messschieber ALINOX .....  
 ..... 11.26, 11.30, 11.34 – 11.35  
 Messschieber Außennuten..... 11.29  
 Messschieber für Bremscheiben..... 11.15  
 Messschieber für Bremsstrommeln..... 11.15  
 Messschieber für Innennuten ..... 11.15  
 Messschieber für Keilnutentiefe ..... 11.13  
 Messschieber für Nutmittenabstands-  
 messung..... 3.11, 6.8, 11.9  
 Messschieber für Zahnweite ..... 11.14  
 Messschieber MULTIPRE ..... 11.31  
 Messschieber parallaxfrei ..... 11.11, 11.27  
 Messschrauben ..... 13.3 – 13.30  
 Messschrauben Amboss verschiebbar .....  
 ..... 13.7, 13.11  
 Messschrauben Draht- und Kugelmessung  
 ..... 13.30  
 Messschrauben eckiger Bügel ... 13.8, 13.30  
 Messschrauben für Innen- und Außen-  
 verzahnung..... 3.18  
 Messschrauben Gewindemessung  
 ..... 13.15 – 13.16  
 Messschrauben Keilnutenmessung ..... 13.33  
 Messschrauben Keilwellenmessung ..... 13.26  
 Messschrauben mit Feinzeiger ... 13.5 – 13.6  
 Messschrauben mit Messuhr ..... 13.6 – 13.7  
 Messschrauben mit Zählwerk ..... 13.3  
 Messschrauben Nutenmessung ..... 13.32  
 Messschrauben Prismenamboss ..... 13.24  
 Messschrauben Rohrwandmessung..... 13.29  
 Messschrauben Sondermessflächen  
 ..... 13.18, 13.25 – 13.29  
 Messschrauben Verzahnungsmessung  
 ..... 13.22 – 13.22  
 Messschrauben Zahnweitenmessung  
 ..... 13.19 – 13.21  
 Messstativ mit Feineinstellung .....5.7  
 Messstativ..... 5.3 – 5.10  
 Messstative für Messbänke .....  
 ..... 7.22, 7.24 – 7.25  
 Messtaster..... 7.22  
 Messtaster Adapter-Set für QUICK CHECK.....

..... 3.17, 6.26  
 Messtisch für Schnellfaster ..... 6.8  
 Messtisch für Vergleichsmessgeräte ..... 6.37  
 Messtische Hartgestein..... 5.9  
 Messtische Keramik ..... 5.8  
 Messtische Stahl ..... 5.10  
 Messuhren ..... 4.3 – 4.13  
 Messuhren DIN 878..... 4.9, 4.11  
 Messuhren mit Bluetooth..... 4.4  
 Messuhren mit Feinzeigermesswerk ..... 4.8  
 Messuhren mit magnetischer Rückwand.....  
 ..... 4.13  
 Messuhren mit rückseitigem Taster ..... 4.13  
 Messuhren Schutzart IP67..... 4.11  
 Messuhren Sicherheitsausführung ..... 4.11  
 Messuhren Zoll-System ..... 4.10  
 Messuhren Zubehör ..... 4.3, 4.14 – 4.17  
 Messuhrhalter mit Feineinstellung..... 4.20  
 Messuhrständer..... 5.7  
 Messwinkelsatz ..... 10.3  
 Messzeugsätze ..... 11.13  
 Meterzähler ..... 14.6  
 Microgauge ..... 6.14  
 MICROLEVEL Richtwaagen ..... 10.14  
 Mikrometer ..... 13.3 – 13.30  
 Mikrometer Amboss verschiebbar .....  
 ..... 13.7, 13.11  
 Mikrometer eckiger Bügel ..... 13.8, 13.30  
 Mikrometer Gewindemessung.....  
 ..... 13.15 – 13.16  
 Mikrometer Keilwellenmessung ..... 13.26  
 Mikrometer mit Feinzeiger ..... 13.5 – 13.6  
 Mikrometer mit Messuhr ..... 13.6 – 13.7  
 Mikrometer mit Zählwerk ..... 13.3  
 Mikrometer Prismenamboss ..... 13.24  
 Mikrometer Rohrwandmessung..... 13.29  
 Mikrometer Sondermessflächen ..... 13.18,  
 ..... 13.25 – 13.29  
 Mikrometer Verzahnungsmessung.....  
 ..... 13.22 – 13.22  
 Mikrometer Zahnweitenmessung  
 ..... 13.19 – 13.21  
 MINI Präzisionsschraubstöcke ..... 8.3  
 MINI Präzisionsschraubstöcke, Satz ..... 8.4  
 Montagelineale aus Aluminium..... 9.6  
 Montagelineale aus Stahl ..... 9.6

## N

Neigungs-Richtwaage ..... 10.20  
 Neigungsmesssystem digital, µLevel .. 10.15  
 Niederzug-Spannstock..... 8.2  
 Nivelliertaster MODUS ..... 10.22  
 Nockenwellenprüfgerät..... 7.2 – 7.3  
 Nutsymmetriemessgerät ..... 3.11

## O

Oberflächenvergleichsnorm ..... 14.13  
 OD Bohrungsmessdorne ..... 6.16  
 OD Gerätehalter..... 6.16  
 OD Messdorne für Innenverzahnungen... 3.14  
 OD Messtiefenanschlag..... 6.17  
 OD Messtiefenverlängerungen..... 6.16  
 ON Innenmessgeräte für Nuten und Einstiche  
 ..... 6.27  
 ON Spreiztaster für Nuten und Einstiche.6.27

OSIMESS Innenfeinmessgeräte..... 6.15  
 OSIMESS Messtisch für Serienkontrolle .. 6.15  
 OSIMESS Zubehör ..... 6.15

## P

Parallel-Einzelendmaße aus Hartmetall .... 1.6  
 Parallel-Einzelendmaße aus Keramik ..... 1.7  
 Parallel-Einzelendmaße aus Stahl ..... 1.5  
 Parallel-Endmaßsätze aus Hartmetall ..... 1.6  
 Parallel-Endmaßsätze aus Keramik..... 1.7  
 Parallel-Endmaßsätze aus Stahl ..... 1.3, 1.4  
 Parallelkastenpaare ..... 8.8  
 Parallelreißer ..... 12.5  
 Parallelstück-Paare ..... 8.15  
 Parallelunterlagen-Sätze ..... 8.16 – 8.17  
 Passameter..... 2.21, 2.23  
 Passungsschieber ..... 2.7  
 Pflegemittel für Messmittel ..... 7.11  
 Plane Messschenkelpaare ..... 1.10  
 Planglasplatten..... 1.10  
 Plattformwaagen ..... 15.3  
 Pneumatische Kegellehren..... 2.16  
 POLDI Schlaghärteprüfer ..... 14.12  
 Präzisionsmaßstäbe aus Stahl..... 9.7  
 Präzisionsschraubstock mit Gewindespindel .  
 ..... 8.5  
 Präzisionsschraubstöcke MINI ..... 8.3  
 Präzisionsschraubstöcke MINI, Satz ..... 8.4  
 Präzisionsthermometer..... 14.7 – 14.8  
 Prismen mit Spannbügel..... 8.13 – 8.14  
 Prismen-Paare aus Spezialguss . 8.14 – 8.15  
 Prismen-Paare aus Stahl..... 8.14  
 Prismenböcke Spezialguss ..... 7.21  
 Prismeneinsätze ..... 7.21  
 Profillehren ..... 9.15  
 Prüfdorne zwischen Spitzen ..... 2.13  
 Prüfungsgewichte für Waagen ..... 15.2  
 Prüfglas-Sätze ..... 13.14  
 Prüflehren für Grenzrachenlehren ..... 2.20  
 Prüfstand für Kraftmessgeräte ..... 15.6  
 Prüfstifte einzeln, aus Hartmetall..... 2.5  
 Prüfstifte einzeln, aus Keramik ..... 2.6  
 Prüfstifte einzeln, aus Spezialstahl ..... 2.5  
 Prüfstiftgriffe ..... 2.4  
 Prüfstifthalter ..... 2.4  
 Prüfstiftsätze aus Spezialstahl ..... 2.4

## Q

QUICK CHECK Universalmessgerät  
 ..... 3.15 – 3.17, 6.24 – 6.26

## R

Rachenlehren..... 2.19 – 2.21  
 Rachenlehren CARBON..... 2.24  
 Radienschablonen ..... 9.16  
 Radiuslehren, einzeln..... 9.15  
 Radiusmessgerät..... 9.15, 9.16  
 Referenzpunkt Einstellgerät ..... 6.44  
 Reifenprofilmaße Tiefenmaße ..... 9.22  
 Reiniger für Tuschierpasten ..... 7.17, 12.14  
 Reißnadeln, Hartmetall..... 12.13  
 Reißnadeln, Stahl..... 12.12  
 Reitstock mit Spannzangenaufnahme ... 7.21  
 Reitstöcke für Spindelstöcke ..... 7.28

Reitstockpaare aus Spezialguss ..... 7.23  
 Richtplatten ..... 7.17  
 Richtwaagen ..... 10.16 – 10.20  
 Richtwaagen aus Aluminium ..... 10.19  
 Richtwaagen für Kurbelzapfen ..... 10.17  
 Richtwaagen mit Feinverstellung ..... 10.16  
 Ring-Lupenleuchte ..... 15.16 – 15.17  
 Rollbandmaße ..... 9.11  
 Rollenböcke ..... 7.22, 7.26 – 7.27  
 Rückprallhärteprüfer SKLEROGRAF ..... 14.12  
 Rundlaufprüfdorne für Morsekegel ..... 2.11  
 Rundlaufprüfdorne für Spindeln ..... 2.12  
 Rundlaufprüfdorne mit Messkugel ..... 2.13  
 Rundlaufprüfgeräte ..... 7.6 – 7.9, 7.18 – 7.28  
 Rundlaufprüfgeräte mit Abrollböcken ..... 7.25  
 Rundlaufprüfgeräte mit HG-Messbank ..... 7.23  
 Rundlaufprüfgeräte Spezialguss ..... 7.20  
 Rundlaufprüfgeräte UNITEST ..... 7.18  
 Rundpassungslehren ..... 2.3 – 2.13, 2.17 – 2.21

**S**

Sägeschränk Messuhr ..... 6.9  
 Schichtdickenmessgeräte ..... 14.15 – 14.16  
 Schlaggeräte für HARTIP ..... 14.10 – 14.11  
 Schlaghärteprüfer POLDI ..... 14.12  
 Schlauch-Wasserwaagen ..... 10.22  
 Schlosserwinkel ..... 10.9  
 Schmiege ..... 10.9 – 10.10  
 Schnellmessgerät für Spaltnessung ..... 9.18  
 Schnellmessgerät für Versatzmessung ..... 9.18  
 Schnellmessgeräte Dreipunkt ..... 13.42 – 13.43  
 Schnellmessgeräte Zweipunkt ..... 13.42 – 13.43  
 Schnellfaster Außenmessung ..... 6.6  
 Schnellfaster für Nutmittenabstandsmessung ..... 3.11, 6.8, 11.9  
 Schnellfaster Innenmessung ..... 6.4  
 Schnittmacherwinkel gehärtet ..... 10.3  
 Schrankunterbau für HG-Messplatten ..... 7.14  
 Schreinerwinkel ..... 10.10  
 Schutzbox für Lehrhinge ..... 2.18, 3.8  
 Schutzhülsen für Gewinde- und Rundpassungslehrdorne ..... 2.9, 3.8  
 Schweißnahtlehre ..... 9.20  
 Sechskantlehren ..... 3.10  
 Sechskantwinkel 120° ..... 10.8  
 Sekundenthermometer ..... 14.8  
 Sendermodule zur Datenübertragung ..... 11.43  
 Shore Härteprüfgeräte ..... 14.13 – 14.14  
 Sinuslineale aus Stahl ..... 9.3  
 Sinustische ..... 8.6  
 Sinustische mit Magnetspannplatte ..... 8.5  
 SK Messgerät ..... 2.15  
 SKLEROGRAF Rückprallhärteprüfer ..... 14.12  
 SL Innenfeinmessgeräte ..... 6.19  
 Snapmatic ..... 2.22  
 Snapmic ..... 2.22  
 Sonder-Messschieber ..... 11.44  
 Sonderlehren und Vorrichtungen ..... 2.26  
 Sondermessstische und Stative ..... 5.7  
 Sonderprüfvorrichtungen ..... 7.6 – 7.9  
 Sonderskalen Standlupen ..... 15.13  
 Sonderskalen Taschenmikroskope ..... 15.14  
 Sonderskalen und Nonien ..... 9.22  
 Spannkraftprüfer ..... 2.13  
 Spannzangen ..... 7.21  
 SPEED SET Voreinstellgeräte ..... 6.21 – 6.23

Spindelstöcke ..... 7.27 – 7.28  
 Spiralbohrer-Schleiflehren ..... 9.19  
 Spitzwinkel 45° / 60° ..... 10.8  
 Spitzzirkel ..... 12.9 – 12.11  
 Spreizfaster für Nuten und Einstiche ..... 6.27  
 SS Innenfeinmessgeräte ..... 6.19  
 Standfuß für Dickenmessgeräte ..... 6.12  
 Standfüße für Messstative ..... 5.5  
 Standlesegläser ..... 15.15  
 Standlupen ..... 15.12 – 15.13, 15.15  
 Stangenzirkel ..... 12.6  
 Stellwinkel ..... 10.9 – 10.10  
 Stoppuhren ..... 14.12  
 Streichmaß ..... 12.8  
 Stückzähler ..... 14.3  
 SU Innenfeinmessgeräte ..... 6.17  
 SU Messbereich-Verlängerungen ..... 6.18  
 Sylvac Messuhren ..... 4.3 – 4.6

**T**

T-Nutschienen für Messplatten ..... 7.13  
 Tablett für Messtaster ..... 6.36, 11.20  
 TALMETER Anreißlehre ..... 9.10, 12.4  
 Taschen-Rollbandmaße ..... 9.11  
 Taschenmessschieber ..... 11.3 – 11.3  
 Taschenmessschieber Linkshänder-Modell ..... 11.12  
 Taschenmessschieber mit Uhrablesung ..... 11.13  
 Taschenmessschieber, parallaxfrei ..... 11.11  
 Taschenmikroskope ..... 15.14  
 Tastaturinterface ..... 11.42  
 Tastbolzenverlängerungen für Messuhren ..... 4.15  
 Taster für CENTRICATOR ..... 6.40  
 Taster für CENTRO ..... 6.42  
 Taster für DIACATOR ..... 6.41  
 Teilscheiben Messschrauben ..... 13.30  
 Teleskoplehren Satz ..... 9.19  
 Teleskopmeter TELEFIX ..... 9.10  
 Temperaturfühler ..... 14.9  
 TGU Vergleichsmessgeräte ..... 6.28 – 6.30  
 Tiefenmessbrücken ..... 4.15, 6.13  
 Tiefenmessbrücken für Taschenmessschieber ..... 11.6  
 Tiefenmessgeräte ..... 6.12 – 6.13  
 Tiefenmessschieber ..... 11.33 – 11.39  
 Tiefenmessschieber ALINOX ..... 11.34 – 11.35  
 Tiefenmessschieber CARBON ..... 11.33  
 Tiefenmessschrauben ..... 13.31 – 13.32  
 Tischlagerungen ..... 7.13  
 Tolerator ..... 2.7  
 Torpedo-Wasserwaagen ..... 10.22  
 Tuschiepaste ..... 7.15, 12.14

**U**

Uhrmacherlupen ..... 15.10  
 Umdrehungszähler ..... 14.4  
 Umfangbandmaße ..... 9.9  
 UNITEST Rundlaufprüfgeräte ..... 7.18  
 Universal Wellenmesszentrum ..... 7.2  
 Universal Winkelmesser ..... 10.12  
 Universalmessgerät QUICK CHECK ..... 3.15 – 3.17, 6.24 – 6.26  
 Universalrachenlehren ..... 2.22  
 Universalvergleichsmessgeräte ..... 6.24 – 6.26,

..... 6.28 – 6.38  
 Untergestelle für HG-Messplatten ..... 7.14  
 Untergestelle für Messbänke ..... 7.24  
 Untergestelle für Messplatten aus Guss ..... 7.16  
 Untergestelle für Richtplatten ..... 7.17  
 Unterlagsfolien Präzisions-Lehrenband ..... 9.14

**V**

Vergleichsmessgeräte ..... 6.24 – 6.26, 6.28 – 6.38  
 Vergleichsmessgeräte für Verzahnungen ..... 3.13, 3.18  
 Verlängerungen für Messuhren ..... 4.15  
 Verlängerungen Innenmessschrauben ..... 13.46  
 Verzahnungslehren ..... 3.12  
 Verzahnungsmessgeräte ..... 3.12  
 Vierkantlehren ..... 3.10

**W**

Wanddickenmessgeräte ..... 14.15  
 Wasserwaagen ..... 10.21  
 Wasserwaagen in Trapezform ..... 10.21  
 Werkstattmessschieber ..... 11.21 – 11.30  
 Werkstattmessschieber ALINOX ..... 11.30  
 Werkzeugvoreinstellgeräte ..... 2.14  
 Winkel-Endmaßsätze aus Stahl ..... 1.8  
 Winkel-Richtwaagen ..... 10.20  
 Winkelaufspannfische ..... 8.7  
 Winkellehre ..... 9.16  
 Winkellehre magnetisch ..... 10.19  
 Winkelmesser ..... 10.11 – 10.12  
 Winkelnormale 90° Dreieckform, Granit ..... 8.11  
 Winkelnormale 90° Rechteckform, Granit ..... 8.12  
 Winkelplatten 90°, Spezialguss ..... 8.10  
 Winkelprismen verstellbar ..... 8.15  
 Winkelprüfgerät 90° ..... 8.10

**X**

XT500 Digital-Innenmessschrauben ..... 13.45  
 XTA Innenmessschrauben ..... 13.46  
 XTD Digital-Innenmessschrauben ..... 13.40 – 13.41  
 XTH Digital-Innenmessschrauben ..... 13.42 – 13.43

**Z**

Zähler ..... 14.3 – 14.6  
 Zentriergerät CENTRICATOR ..... 6.40  
 Zentriergerät CENTRO ..... 6.42  
 Zentriergerät DIACATOR ..... 6.41  
 Zentrierspitzen ..... 7.20  
 Zentrierwinkel ..... 10.8  
 Zimmermannswinkel ..... 10.9  
 Zirkel ..... 12.9 – 12.11  
 Zirkelmessschieber ..... 12.5  
 Zubehör für Fühlhebelmessgeräte ..... 4.18, 4.20  
 Zubehör für Messuhren ..... 4.3, 4.14 – 4.17  
 Zubehör für Universal Winkelmesser ..... 10.12  
 Zubehör für Universalvergleichsmessgeräte TGU ..... 6.29 – 6.30

# 1/2/3...

µLevel spirit level ..... 10.15  
 3D adjusting device ..... 6.42 – 6.44

## A

Accessories for dial gauges.....  
 ..... 4.3, 4.14 – 4.17  
 Accessories for dial test indicators.....  
 ..... 4.18, 4.20  
 Accessories for universal bevel protractors  
 ..... 10.12  
 Accessories for universal comp. inst. TGU  
 ..... 6.29 – 6.30  
 Acute angle squares 45° / 60° ..... 10.8  
 Adapter for comparator gauges ..... 4.15  
 Adapter for dial gauges ..... 4.15  
 ALINOX calipers 11.26, 11.30, 11.34 – 11.35  
 Aluminium levels ..... 10.19  
 Angle clamping tables ..... 8.7  
 Angle finder levels ..... 10.20  
 Angle finder, magnetic..... 10.19  
 Angle gauge block sets, steel..... 1.8  
 Angle gauges ..... 9.16  
 Angle plates with clamping slots..... 8.7  
 Angle plates with T slots ..... 8.8  
 Anti-corrosion oil ..... 1.8  
 Assembling straightedges, aluminium ..... 9.6  
 Assembling straightedges, steel ..... 9.6

## B

Back squares ..... 10.5 – 10.7  
 Back squares, hardened ..... 10.5  
 Balancing stands with floating base..... 7.27  
 Ball gauges, tungsten carbide ..... 1.12  
 Base for measuring stands..... 5.5  
 Base tool cabinet for granite surface plates  
 ..... 7.14  
 Batteries for digital meas. instruments 11.44  
 Bevel edge squares hardened heavy/thin.....  
 ..... 10.4  
 Bevel edge squares, adjustable . 10.3 – 10.4  
 Bevel edge squares, hardened..... 10.4  
 Bevel protractors ..... 10.11 – 10.12  
 Bluetooth-Dongle ..... 11.41  
 Bore gauges..... 6.16  
 Bowers internal micrometers . 13.40 – 13.46

## C

Caliper for flush measurement ..... 9.18  
 Caliper for gap measurement..... 9.18  
 Calipers ..... 12.9 – 12.11  
 Calipers for slot center distance meas.....  
 ..... 3.11, 6.8, 11.9  
 Cam shaft measuring system..... 7.2 – 7.3  
 Carpenter's squares..... 10.9  
 Centre points..... 7.20  
 Centre squares..... 10.8  
 Centring device CENTRICATOR ..... 6.40  
 Centring devices DIACATOR ..... 6.41  
 CENTRO centring device ..... 6.42  
 Chamfer gauge..... 9.15

Chamfer length meas. device ..... 6.27  
 Check gauges for limit snap gauges ..... 2.20  
 Circular illuminated magnifiers 15.16 – 15.17  
 Circular levels and precision vials ..... 10.22  
 Circumference tapes ..... 9.9  
 Clamping cubes with clamping slots ..... 8.9  
 Clamping cubes with T slots ..... 8.9  
 Cleaner for measuring surfaces ..... 7.11  
 Cleaner for surface pastes ..... 7.17, 12.14  
 Clinometer ..... 10.16  
 Coating thickness gauges ..... 14.15 – 14.16  
 Collets ..... 7.21  
 Combination squares ..... 10.12  
 Comparative instruments for gear tooth  
 ..... 3.13, 3.18  
 Comparative meas. instrument.....  
 ..... 6.24 – 6.26, 6.28 – 6.38  
 Comparator gauges with precision movement  
 ..... 4.8  
 Comparator gauges, MYCRO..... 4.7  
 Comparator gauges, MYTAST ..... 4.7  
 Comparator snap gauges..... 2.21, 2.24  
 Compass vernier calipers ..... 12.5  
 Concentricity test plug gauge for morse taper  
 ..... 2.11  
 Concentricity test plug gauge spindles .. 2.12  
 Concentricity test plug gauge with  
 measuring ball..... 2.13  
 Concentricity testers .. 7.6 – 7.9, 7.18 – 7.28  
 Concentricity testers special cast iron ... 7.20  
 Concentricity testers UNITEST ..... 7.18  
 Concentricity testers with balancing stands ..  
 ..... 7.25  
 Concentricity testers with granite bench 7.23  
 Contour gauges..... 9.15  
 Converter..... 2.7  
 Counter..... 14.3 – 14.6  
 Crane scales ..... 15.4 – 15.5  
 Crankpin levels ..... 10.17  
 Crankshaft testing instruments ..... 6.39  
 Custom made measuring devices .. 7.6 – 7.9  
 Custom made vernier calipers ..... 11.44  
 Cylindrical gauges... 2.3 – 2.13, 2.17 – 2.21

## D

Data cable ..... 11.41  
 Data transmission, wireless ..... 11.43  
 Deburring stone..... 1.8  
 Depth bridges for pocket calipers..... 11.6  
 Depth calipers ..... 11.33 – 11.39  
 Depth calipers ALINOX ..... 11.34 – 11.35  
 Depth calipers CARBON ..... 11.33  
 Depth measuring bridges ..... 4.15, 6.13  
 Depth micrometers ..... 13.31 – 13.32  
 Dial caliper gauges external..... 6.6  
 Dial caliper gauges for slot center distance  
 meas. .... 3.11, 6.8, 11.9  
 Dial caliper gauges internal ..... 6.4  
 Dial depth gauges ..... 6.12 – 6.13  
 Dial gauge accessories..... 4.3, 4.14 – 4.17  
 Dial gauge holders with fine adjustment 4.20  
 Dial gauge stands ..... 5.7  
 Dial gauge stands ceramic..... 5.8  
 Dial gauge stands for test benches.....

..... 7.22, 7.24 – 7.25  
 Dial gauge stands granite ..... 5.9  
 Dial gauge stands steel..... 5.10  
 Dial gauges..... 4.3 – 4.13  
 Dial gauges DIN 878 ..... 4.9, 4.11  
 Dial gauges protection class IP67..... 4.11  
 Dial gauges safety model..... 4.11  
 Dial gauges with back plungers ..... 4.13  
 Dial gauges with Bluetooth..... 4.4  
 Dial gauges with inch system ..... 4.10  
 Dial gauges with magnetic back ..... 4.13  
 Dial gauges, large ..... 4.12  
 Dial gauges, small ..... 4.6, 4.8  
 Dial tension gauges KONTAKTOR ..... 15.7  
 Dial test indicator holder..... 4.20  
 Dial test indicators (lever type) .. 4.18 – 4.19  
 Die maker's squares, hardened..... 10.3  
 Digital balances..... 15.2 – 15.5  
 Digital bevel protractors ..... 10.11  
 Digital caliper for flush measurement..... 9.18  
 Digital caliper for gap measurement ..... 9.18  
 Digital calipers..... 11.3 – 11.9,  
 ..... 11.13, 11.16 – 11.19, 11.21 – 11.27  
 Digital calipers ALINOX ..... 11.26  
 Digital calipers CARBON ..... 11.21 – 11.23  
 Digital calipers for (3 / 5) edged tools.. 11.14  
 Digital calipers inside grooves . 11.16 – 11.17  
 Digital calipers IP67 ..... 11.24  
 Digital calipers long jaws ..... 11.25  
 Digital coating thickness gauges  
 ..... 14.15 – 14.16  
 Digital comparative meas. Instruments .....  
 ..... 6.28, 6.31, 6.34 – 6.35, 6.38  
 Digital crane scales ..... 15.4 – 15.5  
 Digital crankshaft testing instruments ... 6.39  
 Digital depth calipers ..... 11.5, 11.33 – 11.38  
 Digital depth gauges..... 6.13  
 Digital dial caliper 3-Point internal ..... 6.3  
 Digital dial caliper gauges external .. 6.5, 6.7  
 Digital dial caliper gauges internal.....  
 ..... 6.2 – 6.3, 6.7  
 Digital dial gauges ..... 4.3 – 4.6  
 Digital dial gauges with scale ..... 4.5  
 Digital dial test indicators (Lever type) .. 4.18  
 Digital external micrometers .....  
 ..... 13.3 – 13.4, 13.16, 13.21, 13.25  
 Digital force measuring gauges . 15.6 – 15.7  
 Digital hand held hanging balances.....  
 ..... 15.3 – 15.4  
 Digital hand tachometers ..... 14.2  
 Digital height gauges ..... 12.2 – 12.3  
 Digital hygro and thermometers ..... 14.10  
 Digital int. micrometers gear measuring 13.23  
 Digital internal measuring instrument... 13.37  
 Digital internal micrometers 2-point  
 ..... 13.40 – 13.45, 13.47  
 Digital internal micrometers 3-point  
 ..... 13.40 – 13.45, 13.47  
 Digital internal micrometers measuring jaws  
 ..... 13.33 – 13.34  
 Digital length rule CARBON ..... 11.31, 15.8  
 Digital micrometer heads 13.5, 13.25, 13.36  
 Digital micrometers .....  
 ..... 13.3 – 13.4, 13.16, 13.21, 13.23, 13.25  
 Digital mounting rules ..... 11.32



Digital platform balances..... 15.3  
 Digital pocket calipers ..... 11.3 – 11.8  
 Digital pocket calipers special meas. Faces  
 ..... 11.7 – 11.8  
 Digital pre-setting device ..... 6.21 – 6.23  
 Digital precision balances..... 15.2  
 Digital precision bore gauges..... 6.14  
 Digital precision thermometers... 14.7 – 14.8  
 Digital protactors ..... 10.13  
 Digital protractor (clinometer)..... 10.19  
 Digital quick response thermometers..... 14.8  
 Digital shore hardness testers ..... 14.13  
 Digital spirit levels ..... 10.21  
 Digital stop watches ..... 14.12  
 Digital surface roughness testers ..... 14.13  
 Digital thickness gauges .... 6.9 – 6.10, 6.12  
 Digital universal meas. caliper 11.16 – 11.19  
 Digital universal meas. caliper ALINOX. 11.26  
 Digital universal meas. caliper CARBON.....  
 ..... 11.16, 11.18 – 11.19  
 Digital wall thickness gauges..... 14.15  
 Digital workshop calipers .....  
 ..... 11.21 – 11.23, 11.26 – 11.27  
 Digital-Depth calipers ALINOX ..... 11.34  
 Digital-Depth calipers CARBON ..... 11.33  
 DIN rules.....2.7  
 Dividers ..... 12.9 – 12.11  
 Double V blocks and clamps .... 8.13 – 8.14  
 Drill and steel wire gauges ..... 9.17  
 DUPLEX lapping and surface plates ..... 7.15  
 Dynamometer..... 15.8

**E**

Edge finders ..... 6.44  
 Engineer's levels ..... 10.16 – 10.20  
 Engineer's levels with fine adjustment 10.16  
 Extensions for dial gauges..... 4.15  
 Extensions internal micrometers..... 13.46  
 External and internal caliper..... 12.11  
 External micrometers ..... 13.3 – 13.30  
 External micrometers deep/angular frames  
 ..... 13.8, 13.30  
 External micrometers gear measurements  
 ..... 13.22 – 13.22  
 External micrometers gear tooth meas.  
 ..... 13.19 – 13.21  
 External micrometers special meas. faces  
 ..... 13.18, 13.25 – 13.29  
 External micrometers spline shaft measuring  
 ..... 13.26  
 External micrometers thread measuring  
 ..... 13.15 – 13.16  
 External micrometers V anvil..... 13.24  
 External micrometers with comparator gauge  
 ..... 13.5 – 13.6  
 External micrometers with counter ..... 13.3  
 External micrometers with dial gauge  
 ..... 13.6 – 13.7  
 External micrometers with movable anvil .....  
 ..... 13.7, 13.11

**F**

Feeler gauge sets ..... 9.12

Filetor ..... 2.7  
 Fine adjustment for measuring stands..... 5.5  
 FISSO measuring stand ..... 5.3  
 Fit rule ..... 2.7  
 Flange squares ..... 10.9  
 Flat jaw (pair) ..... 1.10  
 Flat squares ..... 10.5 – 10.7  
 Flat straightedge, steel..... 9.5  
 Flat straightedges, aluminium ..... 9.4  
 Flexible rules..... 9.9  
 Folding magnifiers ..... 15.11 – 15.12  
 Force measuring device for micrometers  
 ..... 13.12

**G**

Gauge block accessories-sets ..... 1.9  
 Gauge block connector ..... 1.5  
 Gauge block holder ..... 1.9  
 Gauge block sets, ceramic ..... 1.7  
 Gauge block sets, steel..... 1.3, 1.4  
 Gauge block sets, tungsten carbide ..... 1.6  
 Gauge block singles, ceramic ..... 1.7  
 Gauge block singles, steel..... 1.5  
 Gauge block singles, tungsten carbide .... 1.6  
 Goliftest internal micrometers ..... 13.47  
 Granite measuring bench..... 7.24  
 Granite measuring plates ..... 7.11 – 7.12  
 Granite measuring tables ..... 5.9  
 Grip magnifiers ..... 15.15

**H**

Half round jaw (pair)..... 1.10  
 Hand held hanging balances .... 15.3 – 15.4  
 Hand held illuminated magnifiers ..... 15.16  
 Hand speed counters..... 14.3  
 Hand tachometers ..... 14.2  
 Hand tachometers UNIVERSAL..... 14.3  
 Hand tally counters..... 14.3  
 Hand- and footswitch..... 11.43  
 Handles for pin gauges, singles ..... 2.4  
 Handstroboskop ..... 14.3  
 Hardness testers HARTIP ..... 14.10 – 14.11  
 HARTIP hardness testers ..... 14.10 – 14.11  
 Headband magnifiers ..... 15.10  
 Headstocks..... 7.27 – 7.28  
 Height gauges ..... 12.4 – 12.4  
 Height micrometer with counter ..... 13.31  
 Hexagon squares 120° ..... 10.8  
 Hexagonal gauges..... 3.10  
 Holder for CARBON measuring instruments  
 ..... 6.37  
 Holder for QUICK CHECK ..... 3.16, 6.25  
 Holder for snap gauges CARBON ..... 2.25  
 Hole gauge sets ..... 9.19  
 HSK measuring instrument ..... 2.15  
 Hygrometers ..... 14.10

**I**

Illumination unit pocket microscopes... 15.14  
 Illumination unit stand magnifiers ..... 15.13  
 Impact devices for HARTIP..... 14.10 – 14.11  
 Impact hardness testers POLDI..... 14.12

Indicating snap gauges ..... 2.21 – 2.24  
 Indicating snap gauges CARBON ..... 2.24  
 Infrared hand held thermometers ..... 14.7  
 Inserts for depth calipers..... 11.37  
 Inside and outside calipers ..... 12.9  
 Inspection straightedges, hardened steel. 9.4  
 Insulating handles..... 1.8  
 Internal micrometers ..... 13.22 – 13.23,  
 ..... 13.33 – 13.36, 13.38 – 13.39  
 Internal micrometers 2-point .. 13.40 – 13.48  
 Internal micrometers 3-point .. 13.40 – 13.48  
 Internal micrometers gear measuring  
 ..... 13.22 – 13.23  
 Internal micrometers long meas. pins.. 13.36  
 Internal micrometers thread measuring 13.17  
 Internal micrometers with meas. Jaws  
 ..... 13.33 – 13.34  
 Internal precision bore gauges ..... 6.14

**J**

Jet gauges ..... 9.16  
 Joiner's squares ..... 10.10

**K**

Keyboardinterface ..... 11.42  
 Knife straightedges, steel ..... 9.3  
 KONTAKTOR dial tension gauges..... 15.7  
 Kröplin dial caliper gauges..... 6.2 – 6.6  
 KT Precision bore gauges ..... 3.14, 6.18  
 KT Tungsten carbide ball inserts... 3.14, 6.18

**L**

Lamellar blocks ..... 8.6  
 Lapping and surface plates DUPLEX..... 7.15  
 Large field illuminated magnifiers ..... 15.17  
 Large LED-Display ..... 11.42  
 LASER multi-position measuring system .. 7.5  
 Lathe tool gauges..... 9.21  
 LED circular illuminated magnifiers  
 ..... 15.16 – 15.17  
 LED-Display ..... 11.42  
 LEITECH thread gauges ..... 3.9  
 Levelling devices MODUS..... 10.22  
 Levelling jacks ..... 7.13  
 Limit plug gauges, ceramic ..... 2.9  
 Limit plug gauges, cylindrical full form 2.7, 2.8  
 Limit plug gauges, flat with cylindrical  
 measuring surfaces ..... 2.10  
 Limit plug gauges, tungsten carbide ..... 2.9  
 Limit snap gauges ..... 2.19 – 2.21  
 Limit snap gauges, adjustable ..... 2.21  
 Limit thread plug gauges, ceramic ..... 3.8  
 Limit thread snap gauges with rollers ..... 3.9  
 Linen testers ..... 15.10 – 15.11  
 Load cells pressure load measurement . 15.5

**M**

Magnetic base for meas. stands..... 5.5  
 Magnetic clamping plates..... 8.5  
 Magnetic holder ..... 4.14, 5.5  
 Magnetic measuring stand ..... 5.3 – 5.6

Magnetic V blocks ..... 8.12 – 8.13  
 Magnifiers ..... 15.10 – 15.17  
 Marking gauge TALMETER ..... 9.10, 12.4  
 Marking gauges ..... 12.8  
 Marking paints ..... 7.16, 12.14  
 Marking vernier calipers ..... 12.7  
 Marking-off and surface plates ..... 7.16  
 Master square 90° rectangular, granite ..... 8.12  
 Master squares 90°, special cast iron ..... 8.10  
 Master squares 90° triangular, granite ..... 8.11  
 Measuring and marking-off blocks ..... 8.10  
 Measuring ball sets, chrome steel ..... 1.12  
 Measuring ball sets, stainless steel ..... 1.12  
 Measuring ball sets, tungsten carbide ..... 1.12  
 Measuring balls in holder ..... 13.22 – 13.23  
 Measuring balls singels ..... 1.12  
 Measuring counters ..... 14.6  
 Measuring cylinder 90° ..... 8.11  
 Measuring equipment holder ..... 13.12  
 Measuring inserts for dial gauges .....  
 ..... 4.16 – 4.17  
 Measuring inserts for pocket calipers ..... 11.6  
 Measuring inserts for snap gauges ..... 2.25  
 Measuring magnifiers with scale ..... 15.12  
 Measuring modul for shaft measuring system  
 ..... 7.3 – 7.4  
 Measuring pin sets, special steel ..... 2.4  
 Measuring pins, ceramic ..... 2.6  
 Measuring pins, special steel ..... 2.5  
 Measuring pins, tungsten carbide ..... 2.5  
 Measuring probe ..... 7.22  
 Measuring range extensions for TGU ..... 6.28  
 Measuring square sets ..... 10.3  
 Measuring stand ..... 5.3 – 5.10  
 Measuring stand with fine adjustment ..... 5.7  
 Measuring table for comp. instruments ..... 6.37  
 Measuring table for dial caliper gauges ..... 6.8  
 Measuring tables ceramic ..... 5.8  
 Measuring tables granite ..... 5.9  
 Measuring tables steel ..... 5.10  
 Measuring tapes ..... 9.11  
 Measuring tapes for outer diameters ..... 9.8  
 Measuring tapes, pocket size ..... 9.11  
 Measuring tool sets ..... 11.13  
 Measuring wheels for counters ..... 14.6  
 Microgauge ..... 6.14  
 MICROLEVEL precision levels ..... 10.14  
 Micrometer heads .....  
 ..... 13.5, 13.25, 13.36 – 13.37  
 Micrometers ..... 13.3 – 13.30  
 Micrometers deep/angular frames .....  
 ..... 13.8, 13.30  
 Micrometers for gear tooth ..... 3.18  
 Micrometers for grooves ..... 13.32  
 Micrometers gear measurements  
 ..... 13.22 – 13.22  
 ..... 13.19 – 13.21  
 Micrometers keyway widths ..... 13.33  
 Micrometers special meas. faces .....  
 ..... 13.18, 13.25 – 13.29  
 Micrometers spline shaft measuring ..... 13.26  
 Micrometers thread measuring .....  
 ..... 13.15 – 13.16  
 Micrometers tube-wall measuring ..... 13.29

Micrometers V anvil ..... 13.24  
 Micrometers wire and ball measuring .. 13.30  
 Micrometers with comparator gauge .....  
 ..... 2.23, 13.5, 13.6  
 Micrometers with comparator gauge  
 ..... 13.5 – 13.6  
 Micrometers with counter ..... 13.3  
 Micrometers with dial gauge ..... 13.6 – 13.7  
 Micrometers with graduated discs ..... 13.30  
 Micrometers with movable anvil .. 13.7, 13.11  
 Milling tool setting gauges ..... 12.8  
 MINI precision vices ..... 8.3  
 MINI precision vices. Set ..... 8.4  
 Mitre squares 135° ..... 10.8  
 Mounting rules ..... 11.32  
 Mounting stand for thickness gauges ..... 6.12  
 Multi-position meas. system ..... 7.5  
 MULTIPRE offset vernier calipers ..... 11.31

## O

Octagon squares 135° ..... 10.8  
 OD bore gauges ..... 6.16  
 OD depth stop ..... 6.17  
 OD equipment holder ..... 6.16  
 OD measuring depth extensions ..... 6.16  
 OD plug gauge for internal gears ..... 3.14  
 ON int. meas. gauges for slots and grooves  
 ..... 6.27  
 ON Probe for slots and grooves ..... 6.27  
 Optical flats ..... 1.10  
 Optical parallel sets ..... 13.14  
 OSIMESS accessories ..... 6.15  
 OSIMESS precision bore gauges ..... 6.15  
 OSIMESS table for series inspection ..... 6.15

## P

Parallel box pairs ..... 8.8  
 Parallel support sets ..... 8.16 – 8.17  
 Parallel V block pairs ..... 8.15  
 Passameter ..... 2.21, 2.23  
 Pin gauge handles ..... 2.4  
 Pin gauge holder ..... 2.4  
 Pin gauge sets, special steel ..... 2.4  
 Pin gauges singles, ceramic ..... 2.6  
 Pin gauges singles, special steel ..... 2.5  
 Pin gauges singles, tungsten carbide ..... 2.5  
 Pistol grip bore gauge 2-point .....  
 ..... 13.42 – 13.43  
 Pistol grip bore gauge 3-point .....  
 ..... 13.42 – 13.43  
 Platform balances ..... 15.3  
 Pneumatic taper gauges ..... 2.16  
 Pocket calipers ..... 11.3 – 11.3  
 Pocket dial calipers ..... 11.13  
 Pocket microscopes ..... 15.14  
 Pocket slip calipers ..... 9.22  
 Pocket vernier calipers, left-hand ..... 11.12  
 Pocket vernier calipers, parallax free ..... 11.11  
 POLDI impact hardness testers ..... 14.12  
 Precision bore gauges ..... 6.15, 6.17 – 6.19  
 Precision meas. tables ceramic ..... 5.8  
 Precision meas. tables granite ..... 5.9  
 Precision meas. tables steel ..... 5.10

Precision rules, steel ..... 9.7  
 Precision thermometers ..... 14.7 – 14.8  
 Precision vices MINI ..... 8.3  
 Precision vices MINI, set ..... 8.4  
 Precision vices with quick adjustment ..... 8.2  
 Precision vices with sine function ..... 8.3  
 Precision vices with threaded spindle .....  
 ..... 8.2, 8.3  
 Precision vices with threaded spindle ..... 8.5  
 Probe adapter set for QUICK CHECK .....  
 ..... 3.17, 6.26  
 Probe extensions for dial gauges ..... 4.15  
 Probe for slots and grooves ..... 6.27  
 Probes for CENTRICATOR ..... 6.40  
 Probes for CENTRO ..... 6.42  
 Probes for DIACATOR ..... 6.41  
 Probes for QUICK CHECK ..... 3.16, 6.25  
 Probes for universal calipers ..... 6.36, 11.20  
 Protection box for ring gauges ..... 2.18, 3.8  
 Protection box for thread- and cylindrical plug  
 gauges ..... 2.9, 3.8  
 Protractors ..... 10.13  
 Pull-down vices ..... 8.2

## Q

QUICK CHECK universal meas. bench  
 ..... 3.15 – 3.17, 6.24 – 6.26  
 Quick response thermometers ..... 14.8

## R

Radio data transmission ..... 11.43  
 Radius gauge ..... 9.15, 9.16  
 Radius gauges, singles ..... 9.15  
 Reading magnifiers ..... 15.15  
 Rebound hardness testers SKLEROGRAF  
 ..... 14.12  
 Resilience tester ..... 2.13  
 Revolution counters ..... 14.4  
 Rolling blocks ..... 7.22, 7.26 – 7.27  
 Rolling blocks heavy duty ..... 7.26  
 Rules with bevel edge ..... 9.8  
 Rules with bevel edge, steel ..... 9.7  
 Rules, flexible ..... 9.9

## S

Saw setting dial gauges ..... 6.9  
 Screw pitch gauges ..... 9.14  
 Screw-cutting gauges ..... 9.21  
 Scribes, steel ..... 12.12  
 Scribes, tungsten carbide ..... 12.13  
 Sender for data transmission ..... 11.43  
 Serration measuring instruments ..... 3.12  
 Serration spline gauges ..... 3.12  
 Service kit-sets ..... 1.8  
 Setting gauges for micrometers ..... 13.14  
 Setting instrument for comparative meas.  
 Instruments ..... 1.11, 6.20  
 Setting ring gauge set, steel ..... 1.4  
 Setting ring gauges DIN 2250-C ..... 2.17  
 Setting ring gauges, ceramic ..... 2.18  
 Setting ring gauges, tungsten carbide ..... 2.18  
 Shaft keyway gauges (Block gauges) ..... 3.10

Shaft measuring system..... 7.2  
 Shim stock gauge strips..... 9.14  
 Shore hardness testers ..... 14.13 – 14.14  
 Simple squares..... 10.9  
 Sine bars, steel..... 9.3  
 Sine tables ..... 8.6  
 Sine tables with magnetic plates ..... 8.5  
 SK measuring instrument ..... 2.15  
 SKLEROGRAF reoubnd hardness testers 14.12  
 SL Precision bore gauges ..... 6.19  
 Sliding bevel ..... 10.9 – 10.10  
 Sliding T bevels..... 10.9 – 10.10  
 Small vernier calipers ..... 11.10  
 Snap gauges..... 2.19 – 2.21  
 Snap gauges CARBON ..... 2.24  
 Snapmatic..... 2.22  
 Snapmic ..... 2.22  
 Solvent spray for marking colours .....  
 ..... 7.19, 12.14  
 Spare probe for 3D adjusting device  
 ..... 6.42 – 6.43  
 Special gauges and devices ..... 2.26  
 Special measuring tables and stands..... 5.7  
 Special scales and verniers ..... 9.22  
 Special scales pocket microscopes..... 15.14  
 Special scales stand magnifiers..... 15.13  
 SPEED SET pre-setting device..... 6.21 – 6.23  
 Spirit levels ..... 10.21  
 Spirit levels in trapezoidal shape ..... 10.21  
 Spline gauges..... 3.12  
 Spring balance cylindrical dynamometer 15.8  
 Spring calipers..... 12.10  
 Spring dividers..... 12.10  
 Spring gauges Thickness calipers..... 9.22  
 Square gauges ..... 3.10  
 Squareness testers 90° ..... 8.10  
 SS Precision bore gauges ..... 6.19  
 Stand magnifiers..... 15.12 – 15.13, 15.15  
 Stands for cast iron surface plates..... 7.16  
 Stands for granite surface plates ..... 7.14  
 Stands for straightening plates ..... 7.17  
 Stands for test benches ..... 7.24  
 Stop watches ..... 14.12  
 Straight sided spline gauges..... 3.12  
 Straightedges ..... 8.17, 9.3 – 9.8  
 Straightedges with bevel edge ..... 9.8  
 Straightedges, granite ..... 8.18  
 Straightedges, special cast iron..... 8.17  
 Straightening plates ..... 7.17  
 Stroke counters ..... 14.5  
 SU bore gauge ..... 6.17  
 SU Measuring range extensions ..... 6.18  
 Supporting feet for surface plates ..... 7.14  
 Surface gauges ..... 12.5  
 Surface paste..... 7.15, 12.14  
 Surface plates ..... 7.11 – 7.17  
 Surface plates (granite) ..... 7.11 – 7.12  
 Surface plates for meas. and inspection 7.15  
 Surface roughness comparison standards  
 ..... 14.13  
 Sylvac dial gauges ..... 4.3 – 4.6

**T**  
 T-slot bars for granite surface plates ..... 7.13

Tailstock pairs special cast iron ..... 7.23  
 Tailstock with collet holder..... 7.21  
 Tailstocks for headstocks ..... 7.28  
 Tally counters ..... 14.3  
 TALMETER marking gauge ..... 9.10, 12.4  
 Taper bore gauges..... 9.17  
 Taper gauges for chuck flange ..... 2.11  
 Taper gauges for morse taper..... 2.10  
 Taper gauges for steep taper..... 2.11  
 Taper measuring gauge, internal ..... 6.27  
 Taper slot gauges ..... 9.17  
 Taper testing instruments sine principle . 7.19  
 Telescope gauge sets ..... 9.19  
 Telescopic meters TELEFIX..... 9.10  
 Temperature probes ..... 14.9  
 Test benches for concentricity testers ... 7.24  
 Test benches special cast iron..... 7.20  
 Test indicators (lever-type) for dial gauges  
 ..... 4.13  
 Test plug gauges between centres..... 2.13  
 Test stand for force meas. gauges..... 15.6  
 Test weights for balances..... 15.2  
 TGU comparative meas. instrument  
 ..... 6.28 – 6.30  
 Thickness gauge sets ..... 9.12  
 Thickness gauges ..... 6.9 – 6.12  
 Thickness gauges for thin films ..... 6.12  
 Thickness gauges large frames..... 6.11  
 Thickness gauges pipe-wall measurement 6.9  
 Thickness gauges with meas. rollers..... 6.12  
 Thickness strips ..... 9.13  
 Thickness strips sets with wall holder ... 9.13  
 Thread gauges fine threads ISO 1502  
 (DIN 13)..... 3.5  
 Thread gauges LEITECH..... 3.9  
 Thread gauges NPT..... 3.4  
 Thread gauges standard thread ISO 1502  
 (DIN 13)..... 3.3  
 Thread gauges trapezoidal thread DIN 103  
 ..... 3.7  
 Thread gauges tungsten carbide ISO 1502  
 (DIN 13)..... 3.4  
 Thread gauges UNC, UNF..... 3.6  
 Thread gauges UNEF..... 3.7  
 Thread gauges Ww DIN ISO 228 ..... 3.6  
 Thread gauges Ww tapered ..... 3.5  
 Thread inserts ..... 2.25, 13.15 – 13.17  
 Thread inserts for granite plates, etc. .... 7.13  
 Thread inserts for snap gauges ..... 2.25  
 Thread measuring wires ..... 2.6, 13.18  
 Thread rule ..... 2.7  
 Toggle press..... 7.25  
 Tolerator..... 2.7  
 Tool pre-setting instrument ..... 2.14  
 Torpedo spirit levels ..... 10.22  
 Trammels ..... 12.6  
 Tray for measuring probes ..... 6.36, 11.20  
 Try squares heavy base and thin blade.....  
 ..... 10.5, 10.7  
 Twist drill grinding gauges ..... 9.19  
 Tyre tread depth gauges..... 9.22

**U**  
 UNITEST concentricity testers..... 7.18

Universal bevel protractors ..... 10.12  
 Universal comparative meas. instrument  
 ..... 6.24 – 6.26, 6.28 – 6.38  
 Universal measuring bench QUICK CHECK  
 ..... 3.15 – 3.17, 6.24 – 6.26  
 Universal shaft measuring system ..... 7.2  
 Universal snap gauges..... 2.22

**V**  
 V block pairs, special cast iron .. 8.14 – 8.15  
 V blocks special cast iron..... 7.21  
 V blocks, adjustable ..... 8.15  
 V inserts ..... 7.21  
 V-block pairs, special steel ..... 8.14  
 Vernier calipers..... 11.3 – 11.40  
 Vernier calipers (3 / 5) edged tools..... 11.14  
 Vernier calipers ALINOX..... 11.26, 11.30,  
 ..... 11.34 – 11.35  
 Vernier calipers for brake discs ..... 11.15  
 Vernier calipers for brake drums ..... 11.15  
 Vernier calipers for inside grooves ..... 11.15  
 Vernier calipers for keyway depth..... 11.13  
 Vernier calipers for tooth width ..... 11.14  
 Vernier calipers outside grooves..... 11.29  
 Vernier calipers parallax free ..... 11.11, 11.27

**W**  
 Wall thickness gauges ..... 14.15  
 Watchmaker's magnifiers..... 15.10  
 Water level kit ..... 10.22  
 Weld seam gauges..... 9.20  
 Wire inserts thread measuring ..... 2.6, 13.18  
 Workshop vernier calipers ..... 11.21 – 11.30

**X**  
 XT500 digital internal micrometers ..... 13.45  
 XTA internal micrometers ..... 13.46  
 XTD digital internal micrometers.....  
 ..... 13.40 – 13.41  
 XTH digital internal micrometers.....  
 ..... 13.42 – 13.43  
 Zero setter ..... 6.44

## № 10...

10001	1.5
10002	1.5
10011	1.6
10012	1.6
10021	1.7
10022	1.7
10031	1.5
10031	1.8
10032	1.5
10032	1.8
10038	1.4
10054	1.3
10064	1.3
10074	1.3
10074	1.4
10084	1.3
10104	1.6
10114	1.6
10124	1.6
10154	1.7
10164	1.7
10174	1.7
10202	1.8
10485	1.11
10485	6.20
10487	1.11
10487	6.20
10501	1.10
10502	13.14
10511	1.8
10521	1.9
10541	1.9
10551	1.9
10561	1.10
10571	1.10
10581	1.10
10601	1.12
10602	1.12
10611	1.12
10612	1.12
10621	1.12
10622	1.12
10631	2.4
10632	2.4
10640	2.5
10641	2.5
10642	2.5
10643	2.5
10644	2.5
10661	2.4
10662	2.4
10680	2.5
10681	2.5
10682	2.5
10683	2.5
10684	2.5
10685	2.5
10686	2.5
10687	2.5
10688	2.5
10689	2.5
10691	2.5
10692	2.5
10693	2.5
10694	2.5
10695	2.5
10696	2.5
10697	2.5
10698	2.5
10699	2.5
10701	2.7
10711	2.4
10720	2.5
10731	2.5

10741	2.5
10801	2.8
10812	2.8
10823	2.10
10851	2.10
10871	2.9
10881	2.9
10901	3.10
10902	3.10
10911	3.10
10921	3.10
10931	3.10
10941	3.10

## № 11...

11001	2.10
11012	2.10
11101	2.10
11112	2.10
11131	2.15
11132	2.15
11133	2.13
11141	2.15
11142	2.15
11143	2.13
11153	2.13
11211	2.11
11222	2.11
11252	2.11
11254	2.12
11256	2.12
11257	2.12
11258	2.12
11259	2.13
11261	2.11
11262	2.11
11271	2.13
11275	2.13
11281	3.10
11282	3.10
11283	3.10
11284	3.10
11291	3.12
11292	3.12
11293	3.12
11294	3.12
11296	3.12
11297	3.12
11298	3.12
11299	3.12
11321	2.17
11325	2.18
11401	2.19
11411	2.19
11431	2.19
11441	2.19
11501	2.20
11511	2.20
11541	2.21
11551	2.21
11581	2.20
11582	2.20
11591	2.24
11595	2.24
11595	2.25
11599	2.25
11601	2.21
11602	2.21
11605	2.23
11611	2.22
11615	2.22
11615	6.14
11621	2.22
11641	2.7
11651	2.7

## № 12...

12001	3.3
12002	3.3
12005	3.4
12006	3.4
12041	3.3
12042	3.3
12045	3.4
12051	3.3
12052	3.3
12055	3.4
12081	3.9
12082	3.9
12083	3.9
12101	3.5
12102	3.5
12103	3.5
12141	3.5
12142	3.5
12143	3.5
12151	3.5
12152	3.5
12153	3.5
12201	3.7
12241	3.7
12251	3.7
12301	3.6
12341	3.6
12351	3.6
12601	3.6
12602	3.6
12603	3.7
12641	3.6
12642	3.6
12643	3.7
12651	3.6
12652	3.6
12653	3.7
12911	3.4
12913	3.5
12941	3.4
12943	3.5

## № 13...

13001	4.5
13011	4.3
13011	4.6
13011	4.4
13031	4.6
13032	4.6
13041	4.5
13081	4.7
13082	4.7
13085	4.7
13086	4.7
13101	4.8
13111	4.7
13111	4.7
13181	4.10
13201	4.9
13211	4.8
13211	4.9
13221	4.10
13221	4.11
13221	4.12
13222	4.11
13241	4.11
13251	4.13
13261	4.13
13301	4.15
13301	4.16
13302	4.15
13302	4.16

13303	4.17
13304	4.17
13305	4.17
13306	4.17
13307	4.15
13311	4.14
13312	4.14
13321	4.14
13322	4.14
13341	4.3
13361	4.14
13361	5.5
13371	4.20
13381	6.9
13382	6.9
13386	6.9
13395	4.18
13401	4.19
13402	4.19
13411	4.19
13421	4.19
13431	4.19
13431	4.20
13432	4.20
13433	4.20
13451	4.13
13461	4.18
13462	4.18
13473	3.11
13473	6.8
13473	11.9
13481	6.7
13489	6.8
13491	6.7
13501	6.2
13502	6.2
13503	6.2
13506	6.2
13506	6.3
13506	6.5
13507	6.3
13507	6.3
13511	6.5
13512	6.5
13513	6.5
13514	6.5
13521	6.4
13522	6.4
13523	6.4
13534	6.6
13535	6.6
13541	6.4
13552	6.6
13557	6.6
13591	6.9
13601	6.10
13602	6.10
13611	6.11
13612	6.10
13613	6.12
13621	6.12
13622	6.12
13623	6.12
13631	6.12
13632	6.12
13641	6.9
13642	6.9
13651	6.11
13681	6.13
13682	6.13
13691	6.13
13701	6.14
13702	4.15
13702	6.13
13721	6.40
13731	6.40
13741	6.41
13743	6.40
13751	6.39

13761	6.39
13771	6.39
13771	6.39
13781	6.15
13784	6.15
13785	6.14
13791	6.15
13794	6.15
13801	6.15
13803	6.18
13805	6.15
13806	6.15
13811	6.17
13817	6.18
13821	6.17
13825	3.14
13825	6.18
13826	6.18
13841	6.41
13842	6.41
13845	6.42
13846	6.42
13851	6.43
13852	6.43
13855	6.43
13857	6.44
13858	6.42
13858	6.43
13859	6.42
13859	6.43
13861	6.19
13871	6.19
13872	6.19
13881	6.27
13891	6.27
13895	6.27
13901	3.15
13901	6.24
13902	3.17
13902	6.26
13903	6.25
13903	6.36
13903	6.36
13903	11.20
13903	3.16
13904	6.25
13904	3.16
13909	6.26
13909	3.17
13911	6.44
13921	6.44
13931	6.44
13941	3.13
13943	3.13
13944	3.13
13945	3.14
13946	3.14
13952	6.19
13963	6.21
13963	6.22
13964	6.22
13976	6.28
13982	6.28
13982	6.29
13982	6.30
13985	6.34
13986	6.35
13991	6.32
13992	6.33
13993	6.31
13993	6.37
13994	6.37
13995	6.31

## № 14...

14002	5.4
-------	-----

14003	5.3
14004	5.3
14005	5.3
14011	5.4
14031	5.4
14041	5.4
14071	5.6
14092	5.5
14093	5.5
14094	5.5
14095	5.5
14099	5.5
14101	5.6
14111	5.6
14121	5.9
14131	5.7
14181	5.8
14181	5.10
14191	5.9
14201	5.8
14201	5.10
14211	5.9
14221	5.8
14221	5.10
14231	5.9
14261	5.8
14261	5.10
14303	5.7
14501	8.15
14521	8.5
14531	8.5
14541	8.5
14551	8.5
14552	8.5
14561	8.6
14571	8.3
14572	8.3
14575	8.4
14579	8.3
14611	8.9
14621	8.9
14622	8.9
14651	2.14
14652	2.14

## № 15...

15001	7.12
15011	7.12
15021	7.12
15031	7.11
15071	7.13
15081	7.11
15082	7.11
15091	7.13
15101	7.13
15111	7.13
15121	7.14
15125	7.24
15131	7.14
15141	7.14
15181	7.15
15191	7.15
15211	7.15
15221	7.15
15231	7.15
15241	7.13
15251	7.15
15292	7.16
15301	7.16
15313	7.16
15321	7.16
15321	12.14
15322	7.15
15322	12.14
15323	7.19
15323	12.14

15324.....	12.14
15324.....	7.17
15351.....	7.17
15361.....	7.17
15371.....	7.17
15401.....	7.24
15471.....	7.24
15481.....	7.24
15495.....	5.7
15495.....	7.25
15511.....	7.23
15515.....	7.23
15531.....	7.23
15535.....	7.23
15541.....	7.23
15551.....	7.23
15561.....	7.28
15562.....	7.28
15563.....	7.27
15564.....	7.27
15565.....	7.28
15571.....	7.28
15581.....	7.27
15582.....	7.26
15583.....	7.26
15584.....	7.27
15585.....	7.26
15586.....	7.26
15587.....	7.26
15595.....	7.18
15598.....	7.25
15601.....	7.20
15605.....	7.20
15611.....	7.20
15621.....	7.21
15622.....	7.21
15625.....	7.21
15631.....	7.21
15632.....	7.21
15633.....	7.22
15634.....	7.21
15635.....	7.22
15641.....	7.20
15642.....	7.20
15643.....	7.20
15644.....	7.22
15645.....	7.22
15646.....	7.22
15647.....	7.22
15648.....	7.22
15649.....	7.22
15650.....	7.22
15651.....	7.22
15652.....	7.22
15653.....	7.22
15654.....	7.22
15655.....	7.22
15661.....	7.19
15672.....	7.19
15681.....	8.16
15682.....	8.16
15683.....	8.16
15691.....	8.16
15692.....	8.16
15693.....	8.16
15694.....	8.16
15695.....	8.16
15696.....	8.16
15701.....	6.25
15742.....	14.13
15761.....	14.13
15791.....	8.17
15792.....	8.17
15793.....	8.17
15841.....	8.2
15845.....	8.2
15851.....	8.2
15861.....	8.2
15865.....	8.5
15871.....	8.3
15872.....	8.3
15881.....	8.6
15891.....	8.6
15901.....	8.6
15911.....	8.6
15933.....	8.7
15934.....	8.7

15941.....	8.7
15942.....	8.7
15951.....	8.10
15961.....	8.10
15971.....	8.10
15981.....	8.10

## Nº 16...

16001.....	8.10
16011.....	8.10
16021.....	8.11
16022.....	8.11
16025.....	8.11
16031.....	8.12
16032.....	8.12
16035.....	8.12
16037.....	8.12
16038.....	8.12
16039.....	8.12
16051.....	8.7
16071.....	8.7
16091.....	8.7
16111.....	8.8
16131.....	8.8
16151.....	8.8
16191.....	8.8
16211.....	8.8
16231.....	8.8
16251.....	8.8
16271.....	8.8
16291.....	8.8
16311.....	8.11
16321.....	8.11
16331.....	8.11
16391.....	8.10
16401.....	8.13
16411.....	8.13
16421.....	8.14
16441.....	8.13
16442.....	8.13
16451.....	8.14
16461.....	8.14
16471.....	8.14
16481.....	8.14
16501.....	8.15
16502.....	8.15
16511.....	8.15
16512.....	8.15
16521.....	8.15
16522.....	8.15
16561.....	8.13
16565.....	8.12
16571.....	8.13
16581.....	8.12
16581.....	8.13
16601.....	8.15
16611.....	8.15
16661.....	8.17
16671.....	8.17
16681.....	8.17
16685.....	8.17
16689.....	8.18
16691.....	8.18
16701.....	8.18
16721.....	8.17
16731.....	8.17
16741.....	9.4
16742.....	9.4
16761.....	9.3
16771.....	9.3
16781.....	9.3
16811.....	9.6
16812.....	9.6
16821.....	9.6
16822.....	9.6

16825.....	9.6
16825.....	9.6
16831.....	9.6
16832.....	9.6
16841.....	9.5
16851.....	9.5
16855.....	9.4
16861.....	9.5
16871.....	9.5
16872.....	9.7
16874.....	9.7
16875.....	9.4
16881.....	9.4
16881.....	9.7
16881.....	9.5
16891.....	9.5
16901.....	9.5
16905.....	9.4
16911.....	9.5
16921.....	9.5
16941.....	9.3
16951.....	9.3
16981.....	9.7
16982.....	9.7
16991.....	9.7
16992.....	9.7

## Nº 17...

17011.....	10.14
17021.....	10.14
17041.....	10.19
17042.....	10.19
17051.....	10.15
17052.....	10.15
17151.....	10.16
17152.....	10.16
17161.....	10.16
17162.....	10.16
17201.....	10.17
17211.....	10.17
17221.....	10.17
17231.....	10.17
17241.....	10.17
17251.....	10.17
17261.....	10.17
17271.....	10.17
17281.....	10.17
17291.....	10.17
17301.....	10.16
17401.....	10.18
17411.....	10.18
17421.....	10.18
17431.....	10.18
17441.....	10.18
17451.....	10.18
17461.....	10.18
17471.....	10.18
17481.....	10.18
17491.....	10.18
17501.....	10.18
17511.....	10.18
17561.....	10.17
17581.....	10.17
17601.....	10.17

## Nº 18...

18001.....	12.3
18005.....	12.3
18021.....	12.3
18075.....	12.2
18081.....	12.2
18084.....	12.3
18085.....	12.3
18091.....	12.2

18092.....	12.2
18095.....	12.3
18182.....	13.31
18192.....	13.31
18501.....	11.3
18501.....	11.4
18501.....	11.5
18502.....	11.6
18502.....	11.41
18502.....	11.42
18502.....	11.43
18503.....	11.44
18504.....	11.5
18504.....	11.6
18506.....	3.11
18506.....	11.19
18506.....	11.7
18506.....	11.8
18506.....	11.9
18506.....	6.8
18509.....	11.6
18511.....	11.24
18511.....	11.25
18512.....	11.25
18513.....	11.27
18515.....	11.27
18516.....	11.21
18516.....	11.22
18517.....	11.22
18517.....	11.23
18518.....	11.18
18518.....	11.20
18519.....	11.19
18520.....	11.5
18520.....	11.38
18520.....	11.35
18521.....	11.5
18521.....	11.38
18521.....	11.35
18522.....	11.5
18522.....	11.38
18523.....	11.38
18523.....	11.35
18523.....	11.36
18523.....	11.5
18524.....	11.38
18524.....	11.5
18525.....	11.34
18526.....	11.33
18527.....	11.34
18528.....	11.33
18532.....	11.36
18533.....	11.37
18534.....	11.36
18539.....	11.37
18541.....	11.17
18542.....	11.16
18543.....	11.32
18544.....	11.32
18546.....	11.31
18546.....	15.8
18547.....	11.32
18548.....	11.32
18601.....	11.26
18608.....	11.26
18661.....	11.10
18661.....	11.12
18662.....	11.11
18665.....	11.12
18681.....	11.12
18682.....	11.11
18685.....	11.12
18741.....	11.28
18751.....	11.28
18761.....	11.28
18771.....	11.28
18782.....	11.27

18791.....	11.30
18791.....	11.34
18791.....	11.35
18801.....	11.27
18802.....	11.27
18891.....	11.29
18911.....	11.30
18931.....	11.28
18931.....	11.29
18941.....	11.28
18951.....	11.28
18951.....	11.30
18961.....	11.28
18971.....	11.29
18971.....	11.30

## Nº 19...

19021.....	11.31
19042.....	11.31
19052.....	12.7
19053.....	12.7
19102.....	12.7
19121.....	12.7
19151.....	11.13
19241.....	11.14
19251.....	11.14
19261.....	11.15
19262.....	11.16
19263.....	11.18
19271.....	11.15
19281.....	11.29
19291.....	11.29
19391.....	11.38
19401.....	11.40
19411.....	11.39
19421.....	11.40
19421.....	11.38
19421.....	11.39
19431.....	11.35
19481.....	11.40
19491.....	11.39
19521.....	10.3
19532.....	10.3
19561.....	10.4
19571.....	10.4
19591.....	10.3
19601.....	10.3
19611.....	10.4
19621.....	10.4
19631.....	10.5
19641.....	10.5
19651.....	10.5
19661.....	10.4
19671.....	10.4
19681.....	10.5
19691.....	10.5
19701.....	10.5
19711.....	10.4
19711.....	10.5
19711.....	10.6
19711.....	10.7
19712.....	10.4
19712.....	10.5
19712.....	10.6
19712.....	10.7
19771.....	10.6
19781.....	10.6
19791.....	10.6
19801.....	10.6
19811.....	10.6
19821.....	10.6
19831.....	10.6
19841.....	10.6
19851.....	10.7
19871.....	10.7
19891.....	10.7

19911.....	10.8
19921.....	10.8
19931.....	10.8
19941.....	10.8
19971.....	10.8
19981.....	10.8
19982.....	10.8
19991.....	10.8

## Nº 20...

20001.....	10.11
20041.....	10.11
20061.....	10.12
20131.....	13.3
20132.....	13.3
20151.....	13.4
20181.....	2.23
20181.....	13.5
20182.....	2.23
20182.....	13.5
20201.....	13.6
20274.....	13.11
20275.....	13.7
20276.....	13.20
20279.....	13.10
20291.....	13.8
20292.....	13.8
20293.....	13.8
20295.....	13.8
20312.....	13.12
20313.....	13.12
20351.....	13.9
20359.....	13.10
20359.....	13.11
20359.....	13.9
20361.....	13.9
20371.....	13.14
20374.....	13.11
20375.....	13.7
20381.....	13.12
20382.....	13.12
20392.....	13.10
20399.....	13.10
20411.....	13.11
20432.....	13.11
20442.....	13.7
20449.....	13.10
20449.....	13.11
20449.....	13.7
20451.....	13.15
20451.....	13.16
20461.....	2.6
20461.....	13.18
20462.....	2.6
20462.....	13.18
20471.....	13.16
20471.....	13.15
20472.....	13.16
20472.....	13.15
20473.....	13.15
20481.....	13.15
20481.....	13.16
20485.....	2.25
20486.....	2.25
20491.....	13.16
20491.....	13.15
20492.....	13.15
20501.....	13.22
20503.....	13.22
20504.....	13.23
20511.....	13.22
20515.....	13.23
20521.....	13.19
20522.....	13.19
20523.....	13.20
20524.....	13.20

20541	13.21
20542	13.21
20561	13.24
20571	13.24
20581	13.24
20621	13.26
20622	13.26
20641	13.28
20642	13.27
20651	13.28
20652	13.27
20661	13.26
20662	13.29
20671	13.29
20691	13.37
20692	13.25
20741	13.17
20743	13.17
20744	13.17
20801	13.34
20802	13.34
20804	13.35
20806	13.35
20808	13.36
20821	13.35
20831	13.32
20841	13.33
20851	13.34
20852	13.34
20871	13.39
20872	13.39
20873	13.39
20882	13.38
20883	13.38
20901	13.38
20905	13.37
20912	13.32
20921	13.31
20940	13.46
20941	13.46
20942	13.46
20951	13.46
20952	13.46
20961	13.46
20971	13.47
20972	13.47
20991	13.47

## Nº 21...

21001	14.2
21011	14.2
21015	14.2
21061	14.3
21062	14.3
21131	14.3
21141	14.3
21151	14.4
21152	14.4
21153	14.4
21154	14.4
21161	14.3
21171	14.5
21172	14.5
21173	14.5
21174	14.5
21191	14.6
21192	14.6
21201	14.6
21202	14.6
21212	14.8
21213	14.7
21213	14.8
21221	14.8
21222	14.8
21223	14.7

21223	14.8
21251	14.7
21271	14.7
21281	14.10
21301	14.9
21303	14.9
21305	14.8
21372	14.12
21382	14.12
21391	14.12
21401	14.12
21421	14.12
21442	14.11
21442	14.10
21449	14.10
21449	14.11
21462	14.14
21465	14.14
21468	14.13
21481	14.14
21491	14.15
21491	14.16
21499	14.15
21501	15.7
21502	15.7
21503	15.7
21504	15.6
21506	15.7
21509	15.6
21511	15.8
21512	15.8
21551	15.3
21552	15.4
21553	15.4
21569	15.4
21569	15.5
21591	15.10
21592	15.10
21611	15.10
21611	15.11
21621	15.10
21621	15.11
21631	15.11
21632	15.11
21651	15.12
21661	14.12
21661	15.12
21662	15.12
21681	15.15
21701	15.15
21763	15.16
21841	15.16
21842	15.16
21843	15.16
21844	15.16
21844	15.17
21861	15.17
21871	15.17
21873	15.17
21901	15.10
21902	15.10
21911	15.11
21912	15.11
21913	15.12
21921	15.13
21922	15.13
21925	15.13
21925	15.14
21931	15.14
21935	15.13
21935	15.14
21941	15.15
21942	15.15
21951	15.15
21961	15.16

## Nº 22...

22101	15.2
22109	15.5
22131	15.3
22151	15.2
22151	15.3
22501	15.5

## Nº 25...

25001	13.48
25010	13.40
25010	13.41
25011	13.40
25011	13.41
25012	13.40
25012	13.41
25021	13.40
25021	13.41
25022	13.40
25022	13.41
25031	13.45
25032	13.45
25101	13.42
25101	13.43
25102	13.42
25102	13.43
25105	13.42
25105	13.43

## Nº 26...

26001	13.47
26002	13.47

## Nº 30...

30000	6.16
30100	6.16
30200	6.16
30300	6.16
30400	6.16
30500	6.16
30600	6.16
30700	6.16

## Nº 32...

32000	6.16
32200	6.17
32300	6.16

## Nº 40...

40001	9.18
40002	9.18
40021	9.18
40022	9.18

## Nº 50...

50002	13.4
50003	13.21
50004	13.25
50005	13.25
50006	13.33
50032	13.3
50041	13.13
50042	13.13

50045	13.12
50052	13.13
50062	13.30
50091	13.29
50101	13.30
50122	13.30
50132	13.13
50151	9.19
50161	13.30
50162	13.30
50163	13.30
50171	13.33
50182	13.34
50201	13.48
50231	13.48
50241	9.19
50252	13.32
50261	11.13
50401	4.10
50441	5.6
50442	5.6
50612	11.13
50651	11.10
50652	11.10
50691	9.22
50781	11.4
50781	11.14
50782	11.2
50782	11.14
50783	11.4
50783	11.14
50784	11.14
50784	11.14
50821	12.7
50831	12.7
50873	11.15
50881	11.15
50911	12.8
50941	12.4
50945	12.4

## Nº 51...

51001	12.5
51042	12.6
51051	12.6
51062	12.6
51063	12.6
51071	12.6
51072	12.6
51081	12.5
51082	12.5
51121	12.8
51131	12.8
51141	12.8
51151	12.8
51162	12.11
51181	12.12
51201	12.13
51241	12.9
51251	12.9
51261	12.9
51271	12.9
51281	12.9
51291	12.10
51292	12.10
51311	12.10
51321	12.10
51341	12.11
51342	12.11
51351	12.11
51352	12.11
51501	9.12
51505	9.12
51512	9.12
51513	9.12
51514	9.12

51521	9.12
51561	9.13
51571	9.13
51572	9.13
51585	9.14
51595	9.14
51605	9.14
51607	9.21
51611	9.16
51612	9.16
51613	9.19
51621	9.16
51622	9.15
51623	9.15
51633	9.16
51651	9.15
51653	9.16
51663	9.17
51665	9.17
51671	9.17
51681	9.21
51682	9.17
51683	9.17
51691	9.14
51701	9.15
51711	9.15
51721	9.22
51741	9.22
51761	9.20
51763	9.20
51765	9.20
51881	10.9
51882	10.9
51972	10.9
51982	10.9

## Nº 52...

52011	10.9
52012	10.9
52041	10.19
52052	10.10
52063	10.10
52064	10.10
52111	10.10
52112	10.10
52211	10.12
52221	10.12
52232	10.12
52252	10.13
52262	10.13
52272	10.13
52282	10.13
52294	10.12
52411	10.19
52411	11.20
52411	11.25
52411	11.30
52431	10.20
52432	10.20
52441	10.20
52461	10.20
52501	10.22
52511	10.22
52551	10.22
52581	10.21
52643	10.21
52644	10.21
52651	10.21
52692	9.8
52693	9.8
52791	9.8
52851	9.9
52852	9.9
52853	9.8
52854	9.8
52855	9.9

52951	9.9
52952	9.9
52953	9.9
52961	9.9
52962	9.9
52991	9.9

## Nº 53...

53182	9.11
53221	9.10
53221	12.4
53222	9.10
53222	12.4
53223	9.10
53223	12.4
53261	9.11
53262	9.11
53321	9.11
53322	9.11
53761	9.10

## Nº 54...

54051	10.22
-------	-------

## Nº TP...

TP120	2.9
TP120	3.8
TP160	2.9
TP160	3.8
TP180	2.9
TP180	3.8
TP200	2.9
TP200	3.8
TP261	2.9
TP261	3.8
TP301	2.9
TP301	3.8
TP705	2.9
TP705	3.8
TP906	2.9
TP906	3.8

## Nº UB...

UB22x	2.18
UB22x	3.8
UB35x	2.18
UB35x	3.8
UB47x	2.18
UB47x	3.8
UB67x	2.18
UB67x	3.8

**So finden Sie uns:**

ULTRA PRÄZISION MESSZEUGE GMBH  
Weitzkauf 3  
63864 Glattbach / Germany

**How to find us:**

ULTRA PRÄZISION MESSZEUGE GMBH  
Weitzkauf 3  
63864 Glattbach / Germany

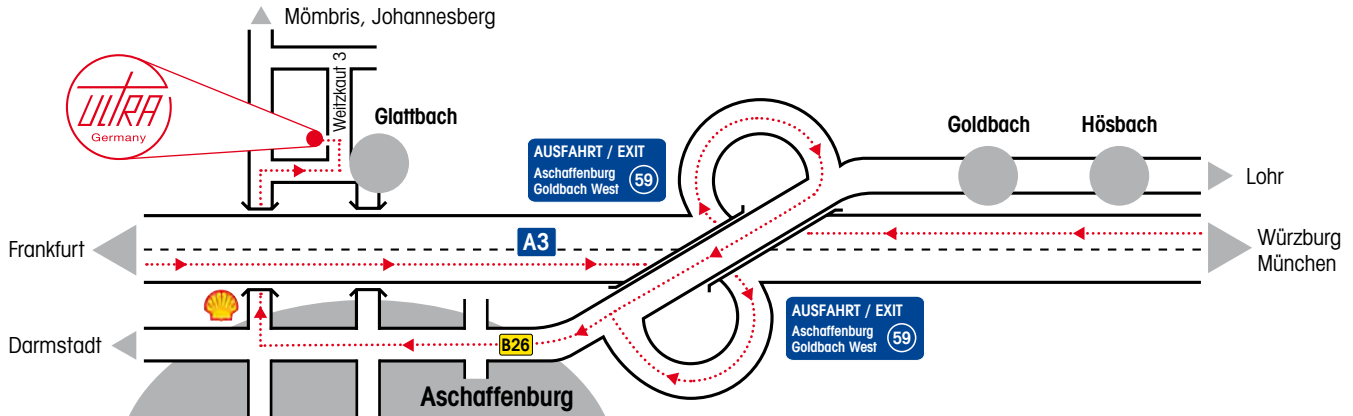

Eine detaillierte Anfahrtsskizze finden Sie auf unserer Homepage:  
[www.ultra-germany.com](http://www.ultra-germany.com) > Kontakt

A detailed road map can be viewed on our home page:  
[www.ultra-germany.com](http://www.ultra-germany.com) > Contact

**Internationale Messen:**

Informieren Sie sich über unsere Leistungsfähigkeit und besuchen Sie uns auf den internationalen Fachmessen.

Aktuelle Messetermine finden Sie auf unserer Homepage:  
[www.ultra-germany.com](http://www.ultra-germany.com) > Aktuelles

**International exhibitions:**

Inform yourselves about our performance during international exhibitions.

Our current exhibition schedule can be viewed on our home page:  
[www.ultra-germany.com](http://www.ultra-germany.com) > Current issues



**Auszug aus den allgemeinen Geschäftsbedingungen der ULTRA PRÄZISION MESSZEUGE GMBH:**

1. Für alle Lieferungen und Leistungen gelten ausschließlich unsere allgemeinen Geschäftsbedingungen. Unternehmen erkennen durch die Entgegennahme unserer Lieferungen und Leistungen die Verbindlichkeit unserer allgemeinen Geschäftsbedingungen an. Erfüllungsort und Gerichtsstand für sämtliche sich aus dem Vertragsverhältnis ergebenden Rechte und Verbindlichkeiten ist Aschaffenburg.

2. Die Vertragsbeziehungen unterliegen ausschließlich dem Recht der Bundesrepublik Deutschland unter Ausschluss des UN-Übereinkommens über den internationalen Warenkauf.

Unsere kompletten AGB können Sie gerne bei uns anfordern oder von unserer Homepage herunterladen:  
[www.ultra-germany.com](http://www.ultra-germany.com) > Kontakt > AGB

**Hinweis zum Katalog:**

Mit diesem Katalog verlieren alle bisherigen Verkaufsunterlagen der ULTRA PRÄZISION MESSZEUGE GMBH ihre Gültigkeit. Abbildungen und Beschreibungen sind unverbindlich. Änderungen bleiben ohne Ankündigung ausdrücklich vorbehalten. Vervielfältigung der Texte und Abbildungen, auch auszugsweise bedürfen unserer ausdrücklichen schriftlichen Genehmigung.

**Extract from the general terms and conditions of sales of ULTRA PRÄZISION MESSZEUGE GMBH:**

1. For all deliveries and services apply our general terms and conditions of sales only. By accepting our deliveries and services, contractors acknowledge our general terms and conditions of sales. For all rights and liabilities resulting from the contractual relationship the place of performance as well as the place of jurisdiction is Aschaffenburg.

2. The law of the Federal Republic of Germany shall apply. The regulations of the UN-purchase law are not applicable.

Our complete general terms and conditions can be requested from us or downloaded from our home page:  
[www.ultra-germany.com](http://www.ultra-germany.com) > Contact > General terms and conditions

**Information about the catalogue:**

This catalogue replaces all previous ULTRA PRÄZISION MESSZEUGE GMBH sales documentation. Illustrations and descriptions are not binding. Contents are subject to change without previous notice. Reproduction of text and illustrations, if partly or completely, requires our express approval.

# ULTRA PRÄZISION

MESSZEUGE GMBH



 **ULTRA PRÄZISION MESSZEUGE GMBH**  
P.O. Box 10 07 52  
63705 Aschaffenburg / Germany

 **ULTRA PRÄZISION MESSZEUGE GMBH**  
Weitzkauf 3  
63864 Glattbach / Germany

Fon: +49 (0) 60 21 42 999 00  
Fax: +49 (0) 60 21 42 999 01

E-Mail: [info@ultra-germany.com](mailto:info@ultra-germany.com)  
Web: [www.ultra-germany.com](http://www.ultra-germany.com)

Steuernummer / Tax No.: 204/140/70133  
UmsatzsteuerID-Nr. / VAT No.: DE 132 104 210

ULTRA Partner:



**TRADITION • PRÄZISION • INNOVATION** seit 1888

**TRADITION • PRECISION • INNOVATION** since 1888